



PARTS CATALOGUE

TILLER HANDLE (6X41)



1E6X4-110E1

()

TILLER HANDLE
PARTS CATALOGUE
©2005 by Yamaha Motor Co., Ltd.
1st edition, June 2005
All rights reserved.
Any reprinting or unauthorized use
without the written permission of
Yamaha Motor Co., Ltd.
is expressly prohibited.
Printed in Japan.

FOREWORD

This Parts Catalogue is related to the parts for the model(s) on the cover page. When you are ordering replacement parts, please refer to this Parts Catalogue and quote both part numbers and part names correctly.

1. Modifications or additions which have been made after the issue of the Parts Catalogue will be announced in the Parts News.

It is advisable that you make the necessary corrections to the Parts Catalogue according to the Parts News.

2. Abbreviations

The following abbreviations are used in this Parts Catalogue.

“UR” Use specified parts number.

“UN” Use as many as needed.

“AP” Alternate Parts

“LM” Locally Made (Parts need to be ordered locally)

“F#” Frame No. (Applicable machine No.)

“O/S” Over Size

3. The number of components for assembly

- Parts, which are to be supplied in an assembly, are listed with a dot (.) in front of the part name as shown below.
- The numeral appearing to the right of each component part indicates the quantity of parts for each assembly unit.

PART NO.	DESCRIPTION	Q'TY	REMARKS
2F5-83310-60	FRONT FLASHER LIGHT ASSY	2	
115-83311-60	.BULB (6V-18W)	1	

4. Applicable colours of graphics are represented in the “REMARKS” as shown below.

PART NO.	DESCRIPTION	Q'TY	REMARKS
2N4-24110-00-X5	FUEL TANK COMP.	2	MXR
3J1-24240-10	.GRAPHIC, FUEL TANK	1	FOR MXR

5. Note that the illustrations for reference in finding parts numbers are not to be used for assembling. When assembling, please use the applicable service manual.

6. The asterisk (*) before a reference number indicates modified items after the first edition.

Application Model

PART NO. / PART NAME											
FIG.NO.											
MODEL CODE	MODEL NAME	SERIAL NO.	6X4-42101-00	6X4-42102-00	6X4-42102-10	6X4-42102-20	6X4-42102-30	6X4-42102-40	6X4-42102-50	6X4-42102-60	6X4-42103-00
			HANDLE, STEERING	FITTING KIT	FITTING KIT	FITTING KIT	FITTING KIT	FITTING KIT	FITTING KIT	FITTING KIT	FITTING KIT
			FIG.1, 2	FIG.3, 5	FIG.4, 5	FIG.6, 7	FIG.8, 9	FIG.10, 12	FIG.11, 12	FIG.13, 14	FIG.15, 16, 17
65W5	F25-2006	65W:1025569-									*
69H6	F30-2006	69H:1004324-	*				*				
67C5	F40-2006	67C:1019598-	*				*				
6C12	F50-2006	6C1:1006292-	*			*					
6C52	F60-2006	6C5:1007597-	*			*					
6C22	T50-2006	6C2:1001851-	*			*					
6C62	T60-2006	6C6:1002114-	*			*					
6D62	F75-2006	62P:1005583-	*		*						
6D82	F90-2006	61P:1013277-	*		*						
68V5	F115-2006	68V:1047289-	*	*							
63DE	40-2006	6H4K:1009434-	*							*	
62XA	50-2006	6H5K:1007157-	*							*	
6H2F	60-2006	6H2K:1005405-	*						*		
6H35	70-2006	6H3K:1004851-	*						*		
6H18	90-2006	6H1:1022036-	*					*			

CONTENTS

BASE HANDLE - ALL	1
BASE HANDLE ELECTRICAL	4
FITTING KIT- F115	5
FITTING KIT- F75, F90	6
FITTING KIT: STEERING FRICTION - F75, F90, F115	7
FITTING KIT- F/T50, F/T60	8
FITTING KIT: STEERING FRICTION - F/T50, F/T60	9
FITTING KIT- F30, F40	10
FITTING KIT: STEERING FRICTION - F30, F40	11
FITTING KIT- 90	12
FITTING KIT- 60, 70	13
FITTING KIT: STEERING FRICTION - 60, 70, 90	14
FITTING KIT- 40, 50	15
FITTING KIT: STEERING FRICTION - 40, 50	16
TILLER HANDLE F25 COMPLETE 1	17
TILLER HANDLE F25 COMPLETE 2	20
TILLER HANDLE F25 COMPLETE 3	21

INDEX

NUMERICAL INDEX	22
-----------------------	----

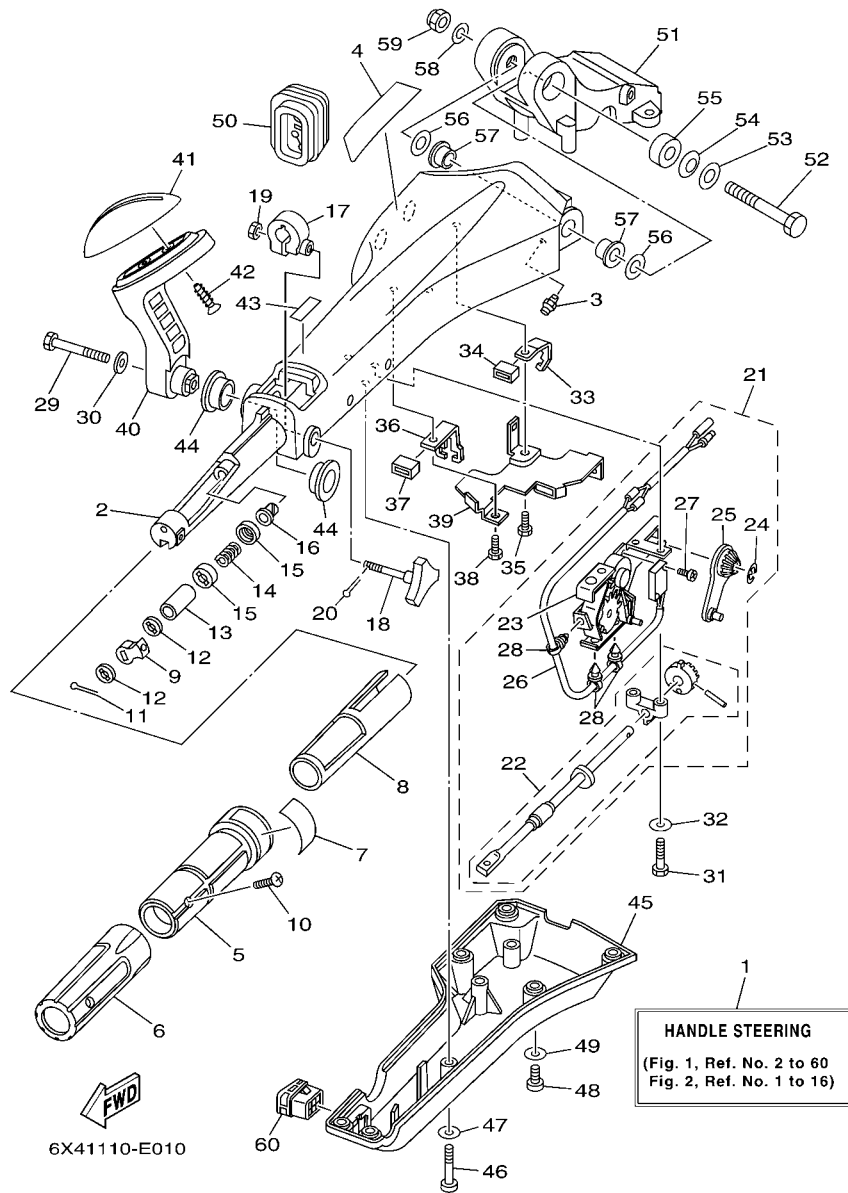

FIG. 1 BASE HANDLE - ALL

REF. NO.	PART NO.	DESCRIPTION	6X41				REMARKS
1	6X4-42101-00	HANDLE, STEERING	1				LM
2	6X4-42111-00-4D	HANDLE, STEERING	1				
3	93700-06M03	NIPPLE, GREASE	1				
4	6X4-48215-00	GRAPHIC	1				
5	6X4-42119-00	GRIP, STEERING HANDLE	1				
6	6X4-42177-00	RUBBER, HANDLE	1				
7	6X4-42137-00	INDICATOR, THROTTLE	1				
8	6X4-41291-00	BUSHING	1				
9	6X4-44139-00	COLLAR	1				
10	90142-05001	SCREW, COUNTERSUNK	1				
11	91490-20010	PIN, COTTER	1				
12	6X4-44177-00	WASHER	2				
13	6X4-42128-00	COLLAR, DISTANCE 1	1				
14	90501-23215	SPRING, COMPRESSION	1				
15	6X4-44188-00	WASHER	2				
16	90386-08032	BUSH	1				
17	63D-42126-00	FRICION, STEERING HANDLE GRIP	1				
18	6X4-48154-00	KNOB, THROTTLE	1				
19	95380-06600	NUT, HEXAGON	1				
20	91490-20010	PIN, COTTER	1				
21	6X4-44100-00	SHIFT LINK ASSY	1				
22	6X4-42115-00	.SHAFT, STEERING HANDLE	1				
23	6X4-44102-00	.SHIFT ASSIST ASSY.	1				
24	6X4-14137-00	.CLIP	1				
25	69W-48261-00	.ARM, THROTTLE	1				
26	6X4-82540-00	.NEUTRAL SWITCH ASSY	1				
27	6A5-48129-10	.SCREW 3	2				

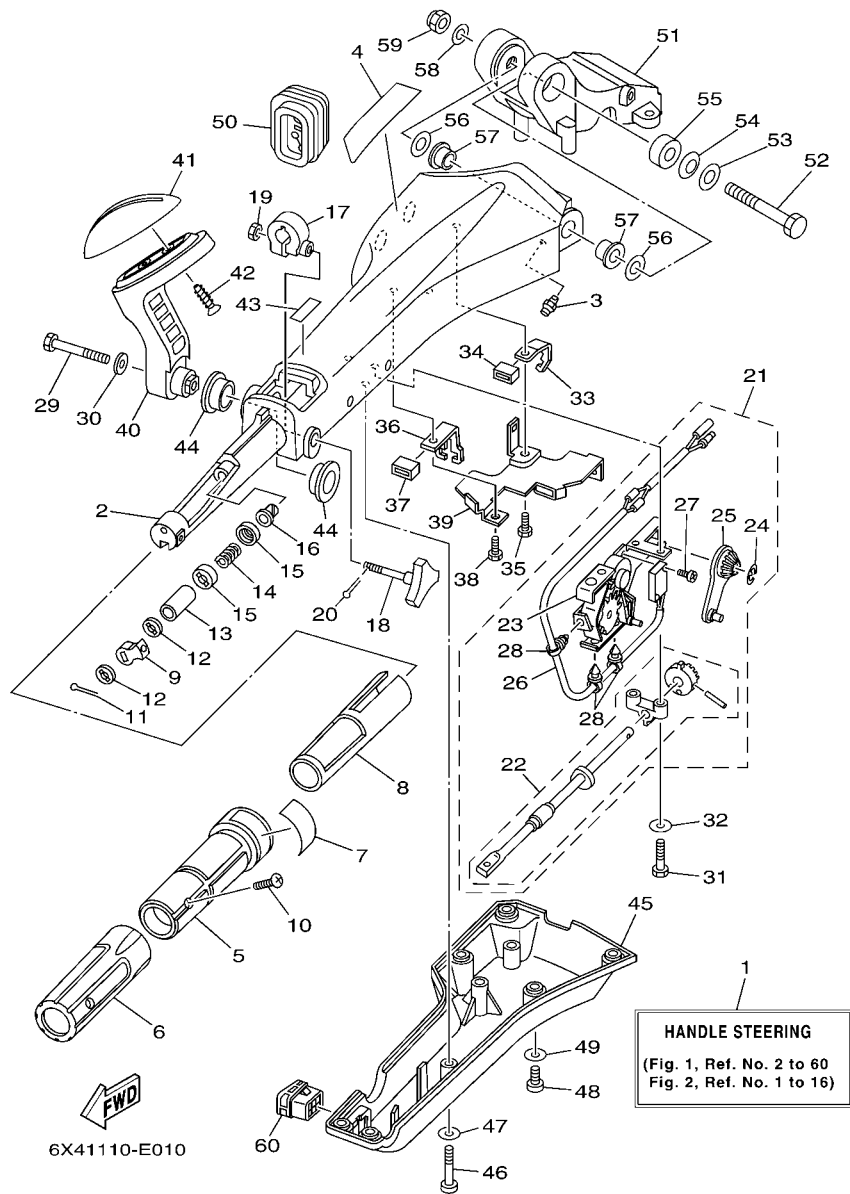
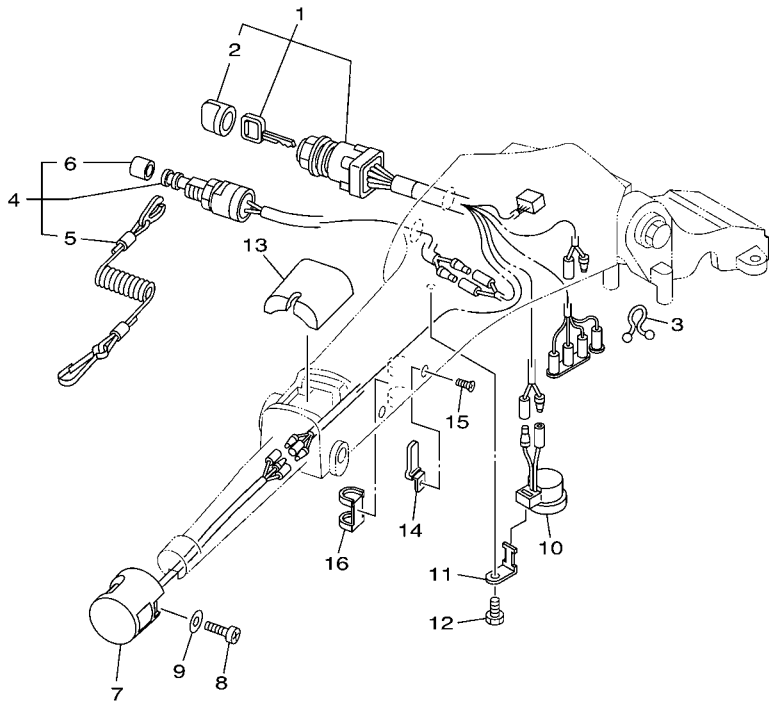

FIG. 1 BASE HANDLE - ALL

REF. NO.	PART NO.	DESCRIPTION	6X41				REMARKS
28	6X4-42821-00	.BAND, CLAMP	3				
29	97095-08040	BOLT	1				
30	92995-08600	WASHER	1				
31	97095-06030	BOLT	2				
32	92995-06600	WASHER	2				
33	6X4-48538-00	CLAMP, CABLE 1	1				
34	6X4-26367-00	PROTECTOR	1				
35	97095-06014	BOLT	1				
36	6X4-48538-10	CLAMP, CABLE 1	1				
37	6X4-26367-00	PROTECTOR	1				
38	97095-06014	BOLT	1				
39	6X4-42159-00	STAY	1				
40	6X4-44159-00-4D	HANDLE, GEAR SHIFT	1				
41	6X4-44173-00	LEVER, SHIFT CONTROL	1				
42	97780-60920	SCREW, TAPPING	2				
43	6G8-44191-00	INDICATOR, SHIFT	1				
44	90386-26MA3	BUSH	2				
45	6X4-42131-00	COVER, HANDLE STEERING	1				
46	97885-06040	SCREW, PAN HEAD	1				
47	92995-06600	WASHER	1				
48	97885-06016	SCREW, PAN HEAD	6				
49	92995-06600	WASHER	6				
50	6X4-42725-00	GROMMET	1				
51	63D-42121-22-4D	BRACKET	1				
52	90101-12014	BOLT	1				
53	92990-12200	WASHER, PLAIN	1				
54	90206-12M22	WASHER, WAVE	1				



 6X41110-E020

FIG. 2 BASE HANDLE ELECTRICAL

REF. NO.	PART NO.	DESCRIPTION	6X41				REMARKS
1	6X4-82510-00	MAIN SWITCH ASSY	1				
2	676-82577-00	.CAP, KEY	1				
3	90464-08M07	CLAMP	1				
4	69W-82575-00	ENGINE STOP SWITCH ASSY	1				
5	682-82556-00	.LANYARD, STOP SWITCH	1				
6	689-8257Y-00	.CAP	1				
7	6X4-82563-00	TRIM & TILT SWITCH ASSY	1				
8	97880-06016	SCREW, PAN HEAD	1				
9	92990-06600	WASHER, PLATE	1				
10	6X4-83383-00	BUZZER	1				
11	6X4-83386-00	STAY, BUZZER	1				
12	97095-06014	BOLT	1				
13	6X4-81942-00	COVER	1				
14	6X4-44554-00	PLATE	2				
15	90152-04015	SCREW, COUNTERSUNK	2				
16	6X4-42724-00	GROMMET	1				

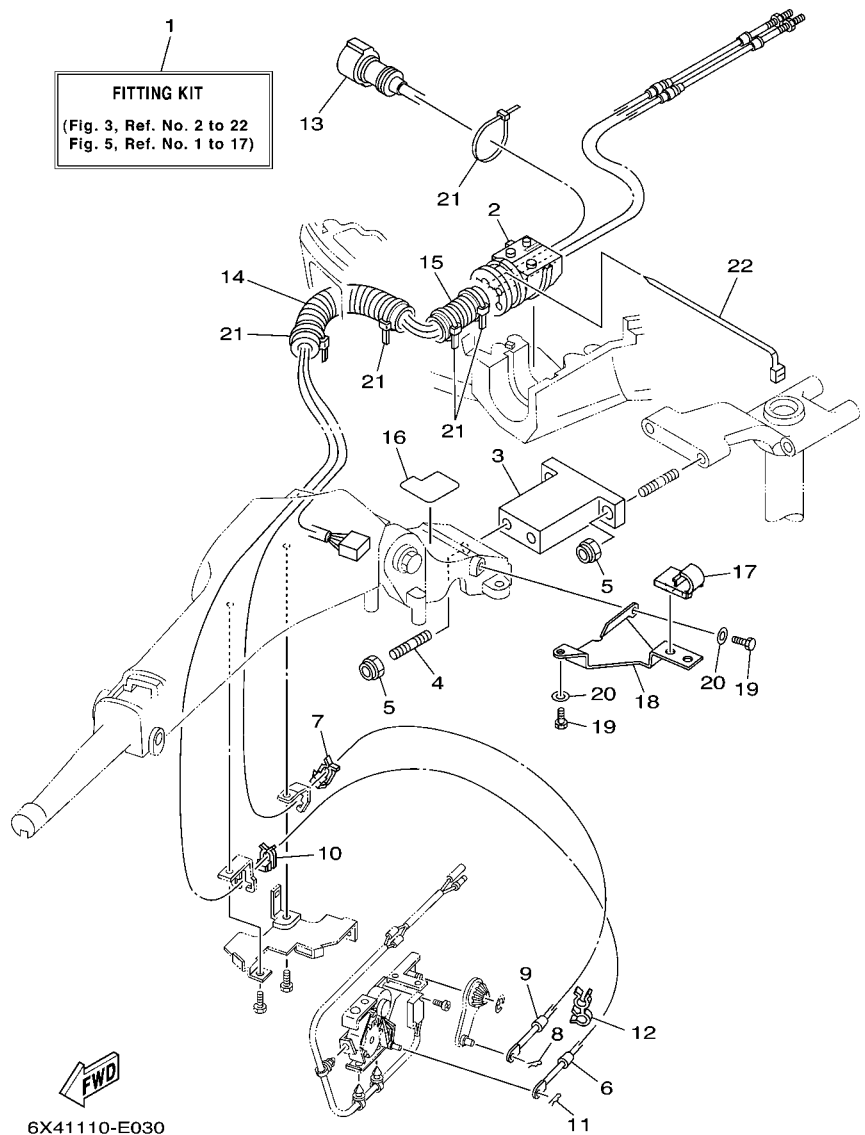

6X41110-E030

FIG. 3 FITTING KIT- F115

REF. NO.	PART NO.	DESCRIPTION	6X41				REMARKS
1	6X4-42102-00	FITTING KIT	1				LM
2	68V-42725-10	GROMMET	1				
3	6X4-42121-10-4D	BRACKET	1				
4	90116-10175	BOLT, STUD	2				
5	90185-10051	NUT, SELF-LOCKING	4				
6	67G-48321-20	CABLE	1				
7	63D-48538-00	CLAMP, CABLE 1	1				
8	90468-10005	CLIP	1				
9	67G-26301-10	THROTTLE CABLE ASSY	1				
10	63D-48538-00	CLAMP, CABLE 1	1				
11	90468-10005	CLIP	1				
12	90464-09M42	CLAMP	1				
13	6X4-82586-20	EXT., WIRE HARNESS (L: 1.25M)	1				
14	90447-22007	HOSE, WITH SPRING	1				
15	6G5-83557-00	TUBE	1				
16	6X4-42735-00	PROTECTOR	1				
17	63D-24367-00	CLAMP, FUEL PIPE 2	1				
18	6X4-24364-00	STAY	1				
19	97095-06016	BOLT	2				
20	92995-06600	WASHER	2				
21	90465-13M24	CLAMP	5				
22	90465-13M30	CLAMP	1				

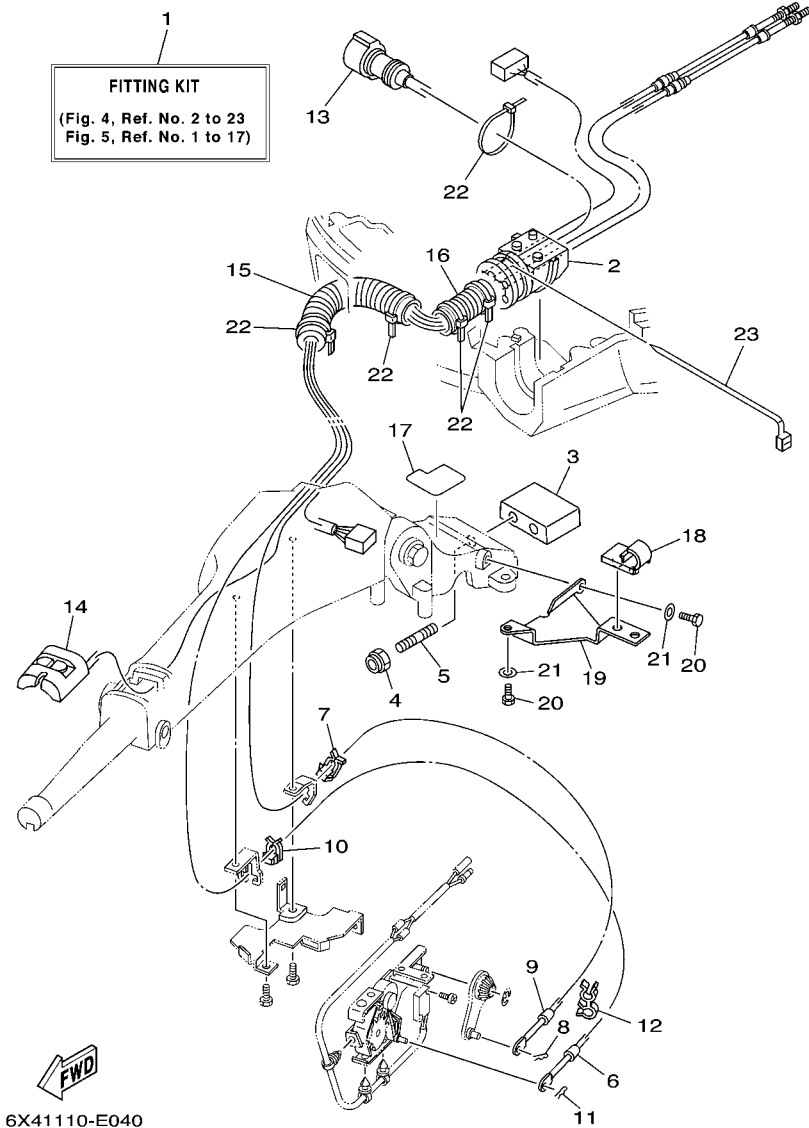

6X41110-E040

FIG. 4 FITTING KIT- F75, F90

REF. NO.	PART NO.	DESCRIPTION	6X41				REMARKS
1	6X4-42102-10	FITTING KIT	1				LM
2	68V-42725-10	GROMMET	1				
3	6X4-42121-00-4D	BRACKET	1				
4	90185-10051	NUT, SELF-LOCKING	2				
5	90116-10031	BOLT, STUD	2				
6	67G-48321-20	CABLE	1				
7	63D-48538-00	CLAMP, CABLE 1	1				
8	90468-10005	CLIP	1				
9	67G-26301-10	THROTTLE CABLE ASSY	1				
10	63D-48538-00	CLAMP, CABLE 1	1				
11	90468-10005	CLIP	1				
12	90464-09M42	CLAMP	1				
13	6X4-82586-20	EXT., WIRE HARNESS (L: 1.25M)	1				
14	6X4-81860-00	SWITCH ASSY	1				
15	90447-22007	HOSE, WITH SPRING	1				
16	6K3-83557-00	TUBE	1				
17	6X4-42735-00	PROTECTOR	1				
18	63D-24367-00	CLAMP, FUEL PIPE 2	1				
19	6X4-24364-00	STAY	1				
20	97095-06016	BOLT	2				
21	92995-06600	WASHER	2				
22	90465-13M24	CLAMP	5				
23	90465-13M30	CLAMP	1				

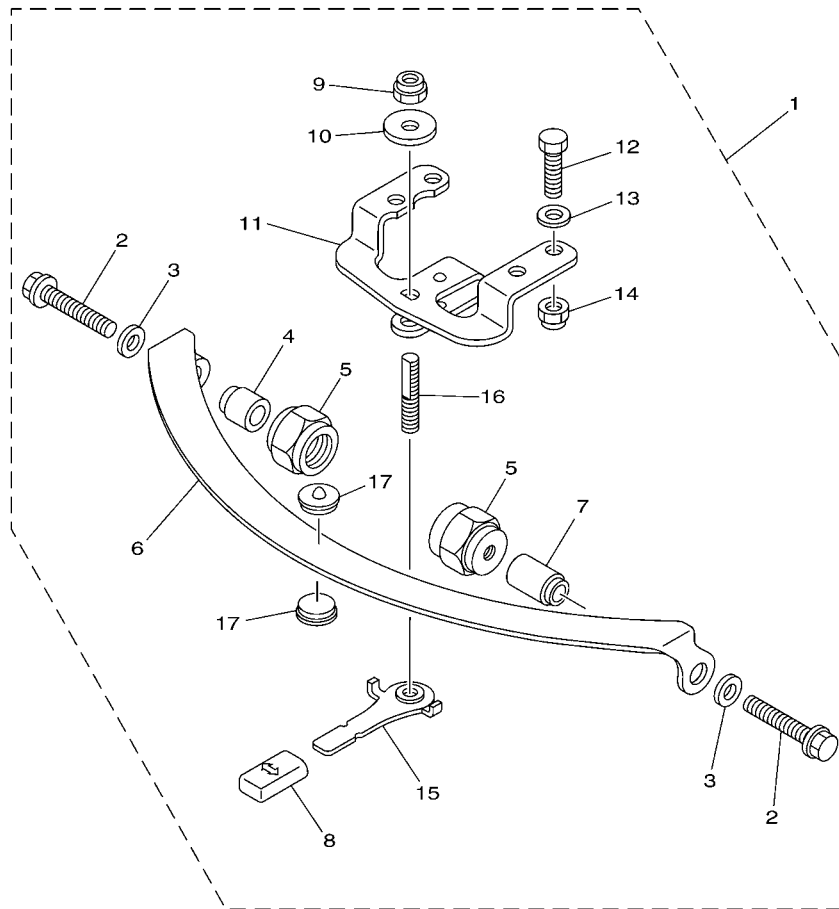

 6X41110-E050

FIG. 5 FITTING KIT: STEERING FRICTION - F75, F90, F115

REF. NO.	PART NO.	DESCRIPTION	6X41				REMARKS
1	67G-42508-10	STEERING FRICTION ASSY	1				
2	90119-08M74	.BOLT, WITH WASHER	2				
3	90201-08M01	.WASHER, PLATE	2				
4	67G-42541-00	.DAMPER	1				
5	67G-42546-00	.NUT	2				
6	63D-42527-00	.PLATE, FRICTION	1				
7	67G-42541-10	.DAMPER	1				
8	682-43318-01	.COVER	1				
9	90185-10M14	.NUT, SELF-LOCKING	1				
10	90201-10M76	.WASHER, PLATE	1				
11	6X4-42526-00	.PLATE, FRICTION	1				
12	97095-08025	.BOLT	2				
13	92995-08600	.WASHER	2				
14	90185-08057	.NUT, SELF-LOCKING	2				
15	67G-42561-00	.KNOB, STEERING LOCK	1				
16	67G-42562-00	.SHAFT, STEERING LOCK	1				
17	63D-42528-00	.PLATE, FRICTION	2				

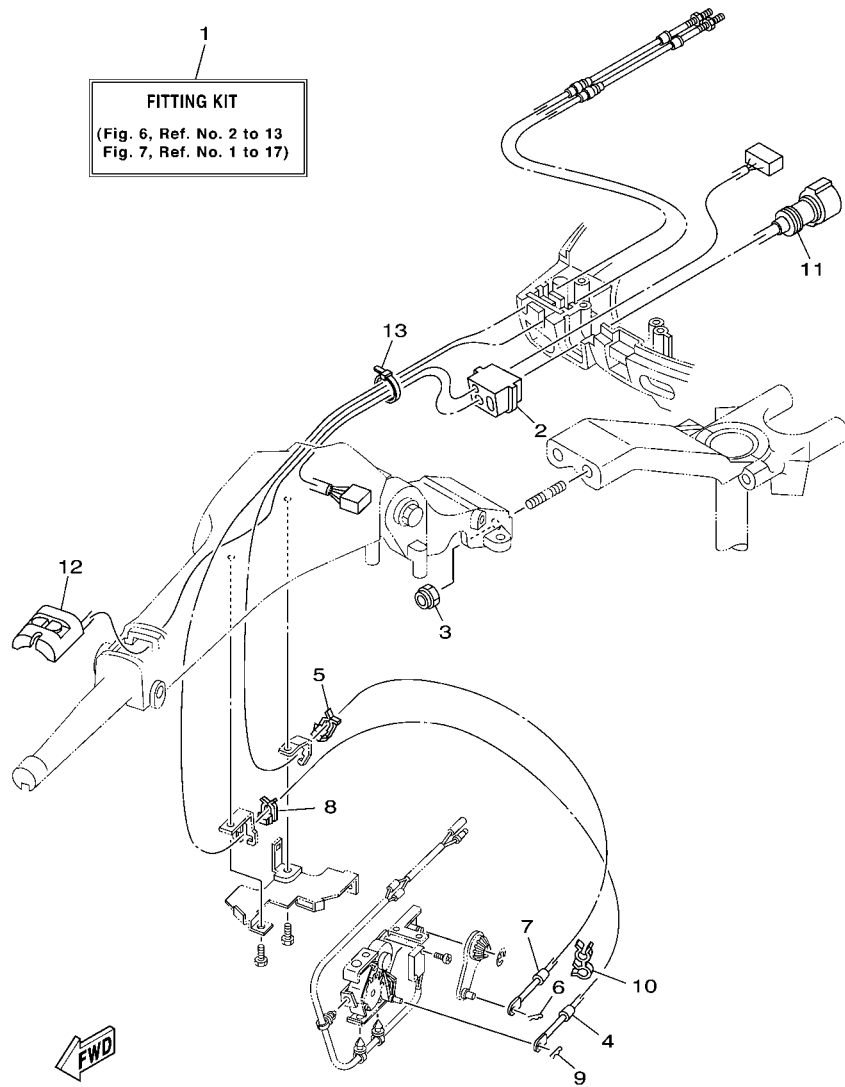

6X41110-E060

FIG. 6 FITTING KIT- F/T50, F/T60

REF. NO.	PART NO.	DESCRIPTION	6X41				REMARKS
1	6X4-42102-20	FITTING KIT	1				LM
2	6C5-42725-30	GROMMET	1				
3	90185-10051	NUT, SELF-LOCKING	2				
4	67C-48321-10	CABLE	1				
5	63D-48538-00	CLAMP, CABLE 1	1				
6	90468-10005	CLIP	1				
7	69W-26301-00	THROTTLE CABLE ASSY	1				
8	63D-48538-00	CLAMP, CABLE 1	1				
9	90468-10005	CLIP	1				
10	90464-09M42	CLAMP	1				
11	6X4-82586-10	EXT., WIRE HARNESS (L: 950MM)	1				
12	6X4-81860-00	SWITCH ASSY	1				
13	90465-13M36	CLAMP	1				

FIG. 7 FITTING KIT: STEERING FRICTION - F/T50, F/T60

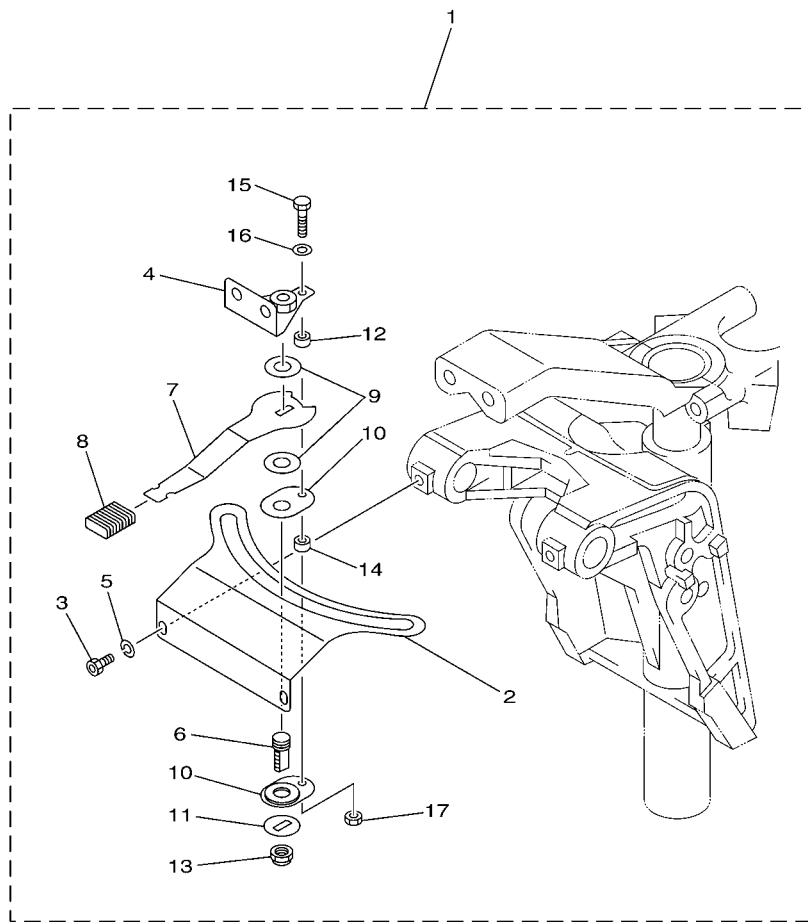

6C11010-D220

REF. NO.	PART NO.	DESCRIPTION	6X41				REMARKS
1	6C5-42508-00	STEERING FRICTION ASSY	1				
2	6C5-42527-00	.PLATE, FRICTION	1				
3	90109-06M88	.BOLT	2				
4	67C-42525-00	.PLATE, FRICTION	1				
5	92990-06100	.WASHER, SPRING	2				
6	67C-42562-00	.SHAFT, STEERING LOCK	1				
7	67C-42561-00	.KNOB, STEERING LOCK	1				
8	689-43633-00	.COVER, TILT LEVER	1				
9	90202-10M56	.WASHER, PLATE	2				
10	65W-42528-00	.PLATE, FRICTION	2				
11	90209-10M26	.WASHER	1				
12	90387-05M05	.COLLAR	1				
13	90185-10M14	.NUT, SELF-LOCKING	1				
14	90387-05M11	.COLLAR	1				
15	97095-05020	.BOLT	1				
16	92995-05600	.WASHER	1				
17	95380-05600	.NUT	1				

1
FITTING KIT
 (Fig. 8, Ref. No. 2 to 12
 Fig. 9, Ref. No. 1 to 17)

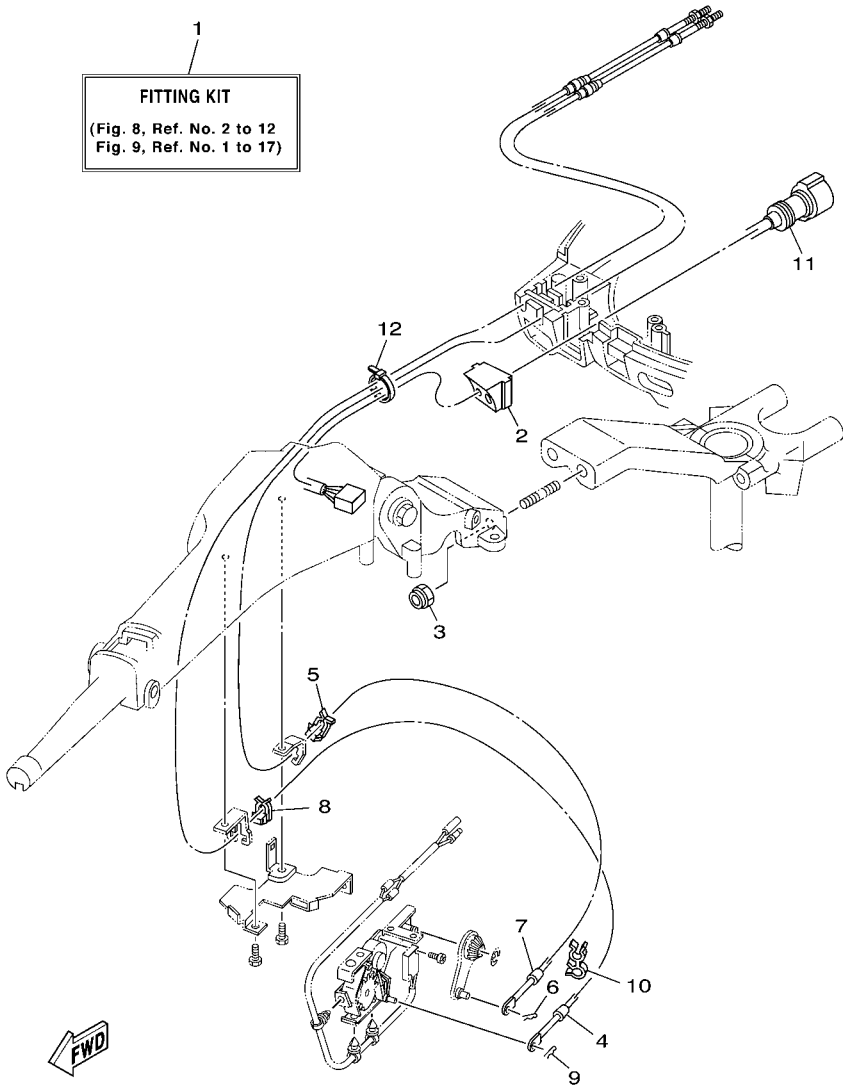

FWD
 6X41110-E080

FIG. 8 FITTING KIT- F30, F40

REF. NO.	PART NO.	DESCRIPTION	6X41				REMARKS
1	6X4-42102-30	FITTING KIT	1				LM
2	62Y-42725-30	GROMMET	1				
3	90185-10051	NUT, SELF-LOCKING	2				
4	67C-48321-10	CABLE	1				
5	63D-48538-00	CLAMP, CABLE 1	1				
6	90468-10005	CLIP	1				
7	69W-26301-00	THROTTLE CABLE ASSY	1				
8	63D-48538-00	CLAMP, CABLE 1	1				
9	90468-10005	CLIP	1				
10	90464-09M42	CLAMP	1				
11	6X4-82586-00	EXT., WIRE HARNESS (L: 700MM)	1				
12	90465-13M36	CLAMP	1				

FIG. 9 FITTING KIT: STEERING FRICTION - F30, F40

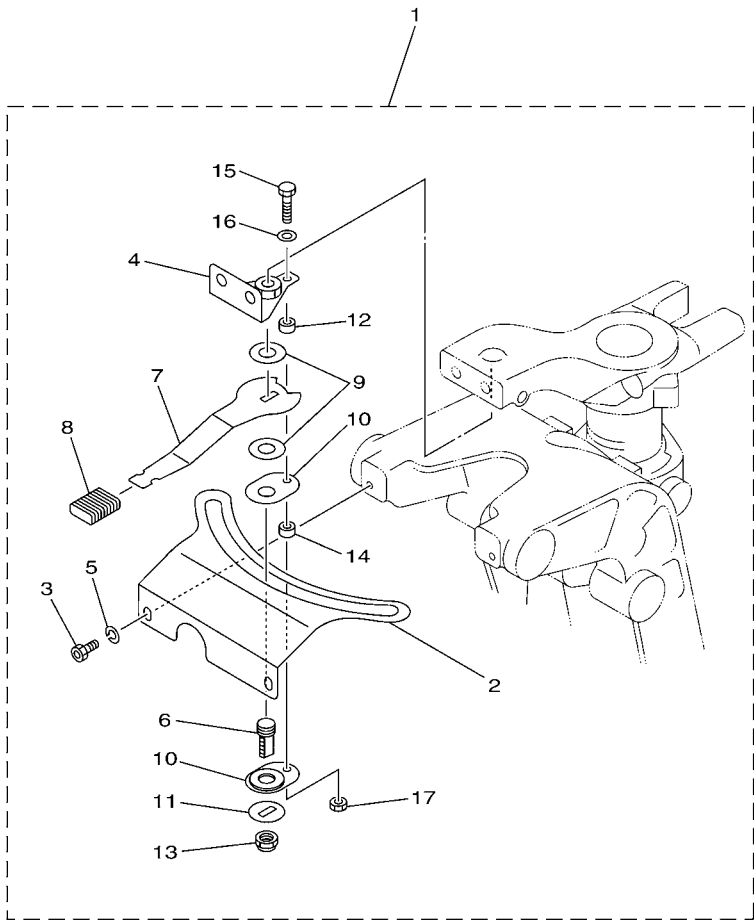

67C3100-C200

REF. NO.	PART NO.	DESCRIPTION	6X41				REMARKS
1	67C-42508-03	STEERING FRICTION ASSY	1				
2	67C-42527-03	.PLATE, FRICTION	1				
3	90109-06M88	.BOLT	2				
4	67C-42525-00	.PLATE, FRICTION	1				
5	92990-06100	.WASHER, SPRING	2				
6	67C-42562-00	.SHAFT, STEERING LOCK	1				
7	67C-42561-00	.KNOB, STEERING LOCK	1				
8	689-43633-00	.COVER, TILT LEVER	1				
9	90202-10M56	.WASHER, PLATE	2				
10	65W-42528-00	.PLATE, FRICTION	2				
11	90209-10M26	.WASHER	1				
12	90387-05M05	.COLLAR	1				
13	90185-10M14	.NUT, SELF-LOCKING	1				
14	90387-05M11	.COLLAR	1				
15	97095-05020	.BOLT	1				
16	92995-05600	.WASHER	1				
17	95380-05600	.NUT	1				

FIG. 10 FITTING KIT- 90

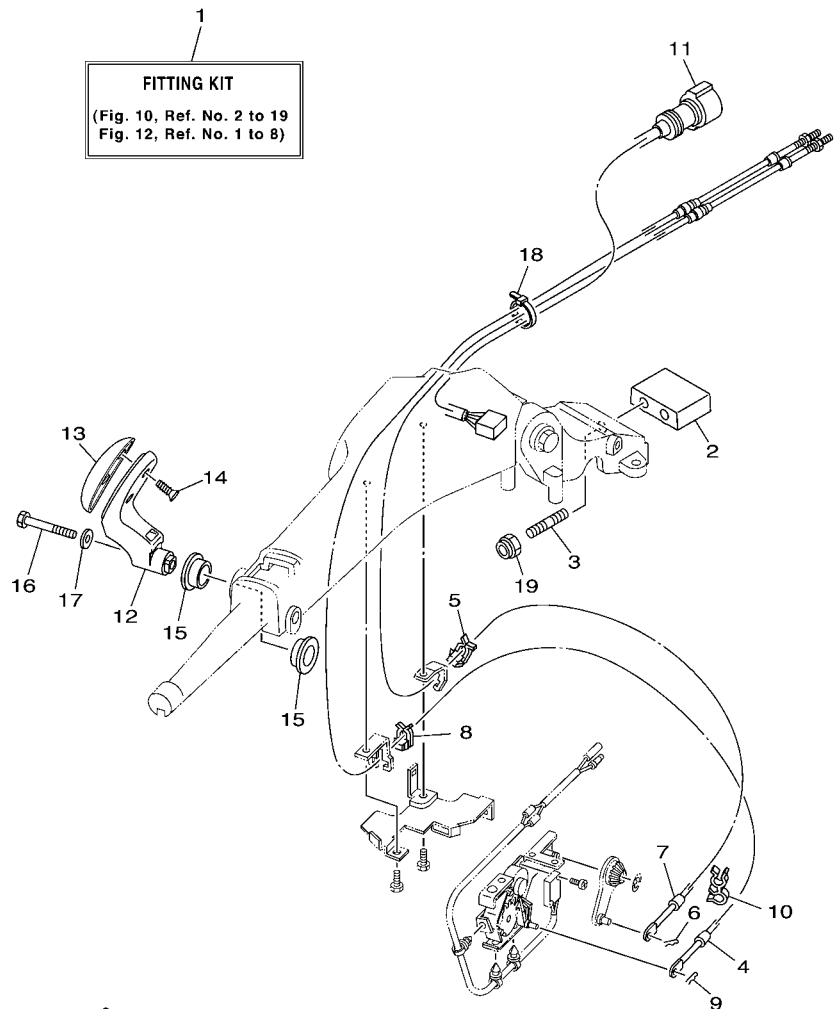

FITTING KIT
 (Fig. 10, Ref. No. 2 to 19
 Fig. 12, Ref. No. 1 to 8)

REF. NO.	PART NO.	DESCRIPTION	6X41				REMARKS
1	6X4-42102-40	FITTING KIT	1				LM
2	6X4-42121-00-4D	BRACKET	1				
3	90116-10031	BOLT, STUD	2				
4	6H1-48321-10	CABLE	1				
5	63D-48538-00	CLAMP, CABLE 1	1				
6	90468-10005	CLIP	1				
7	6H1-26301-01	THROTTLE CABLE ASSY	1				
8	63D-48538-00	CLAMP, CABLE 1	1				
9	90468-10005	CLIP	1				
10	90464-09M42	CLAMP	1				
11	6X4-82586-30	EXTENSION, WIRE HARNESS	1				
12	6X4-44159-10-4D	HANDLE, GEAR SHIFT	1				
13	6X4-44173-00	LEVER, SHIFT CONTROL	1				
14	97780-60920	SCREW, TAPPING	2				
15	90386-26MA3	BUSH	1				
16	97095-08040	BOLT	1				
17	92995-08600	WASHER	1				
18	90465-13M36	CLAMP	1				
19	90185-10051	NUT, SELF-LOCKING	2				

FWD
 6X41110-E100

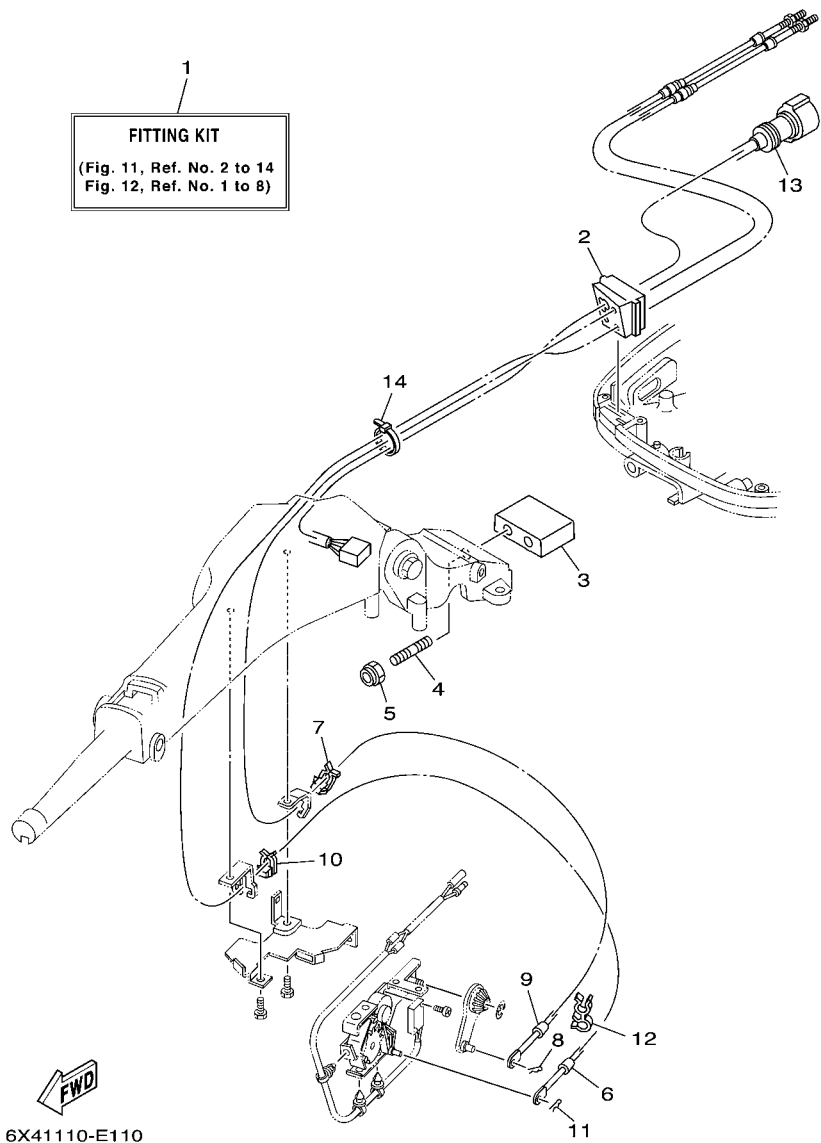

1
FITTING KIT
 (Fig. 11, Ref. No. 2 to 14
 Fig. 12, Ref. No. 1 to 8)

6X41110-E110

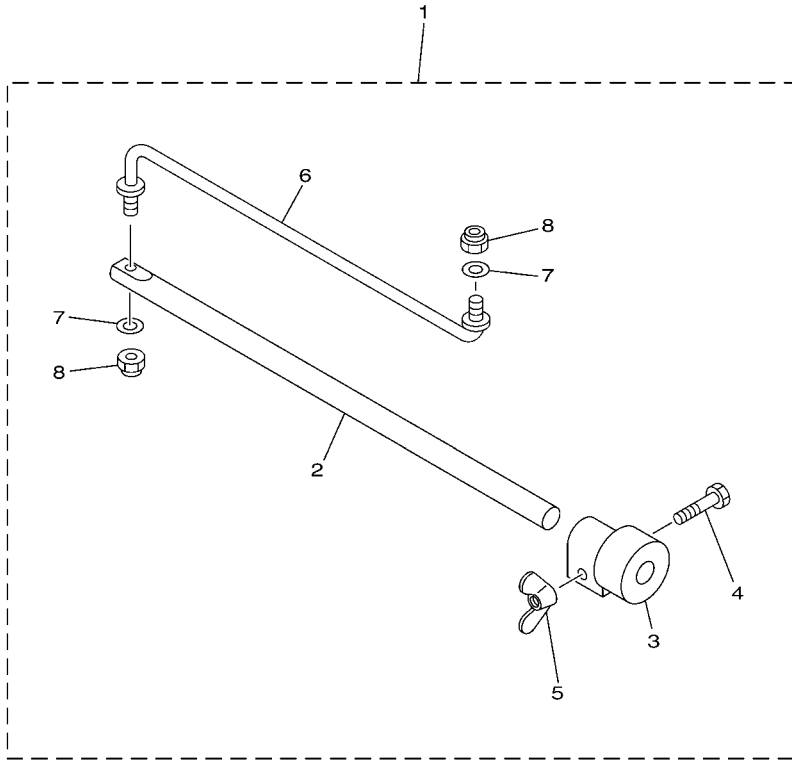

FIG. 11 FITTING KIT- 60, 70

REF. NO.	PART NO.	DESCRIPTION	6X41				REMARKS
1	6X4-42102-50	FITTING KIT	1				LM
2	6H3-42725-30	GROMMET	1				
3	6X4-42121-00-4D	BRACKET	1				
4	90116-10031	BOLT, STUD	2				
5	90185-10051	NUT, SELF-LOCKING	2				
6	6H3-48321-10	CABLE	1				
7	63D-48538-00	CLAMP, CABLE 1	1				
8	90468-10005	CLIP	1				
9	6H3-26301-01	THROTTLE CABLE ASSY	1				
10	63D-48538-00	CLAMP, CABLE 1	1				
11	90468-10005	CLIP	1				
12	90464-09M42	CLAMP	1				
13	6X4-82586-30	EXTENSION, WIRE HARNESS	1				
14	90465-13M36	CLAMP	1				

FIG. 12 FITTING KIT: STEERING FRICTION - 60, 70, 90

REF. NO.	PART NO.	DESCRIPTION	6X41				REMARKS
1	692-42508-01	STEERING FRICTION ASSY	1				
2	663-42518-00	.SHAFT, FRICTION	1				
3	663-42528-00	.PLATE, FRICTION	1				
4	97080-06035	.BOLT	1				
5	90175-06003	.NUT, WING	1				
6	692-42515-01	.ROD, STEERING LINK	1				
7	92990-08600	.WASHER, PLATE	2				
8	90185-08057	.NUT, SELF-LOCKING	2				



6X41110-E120

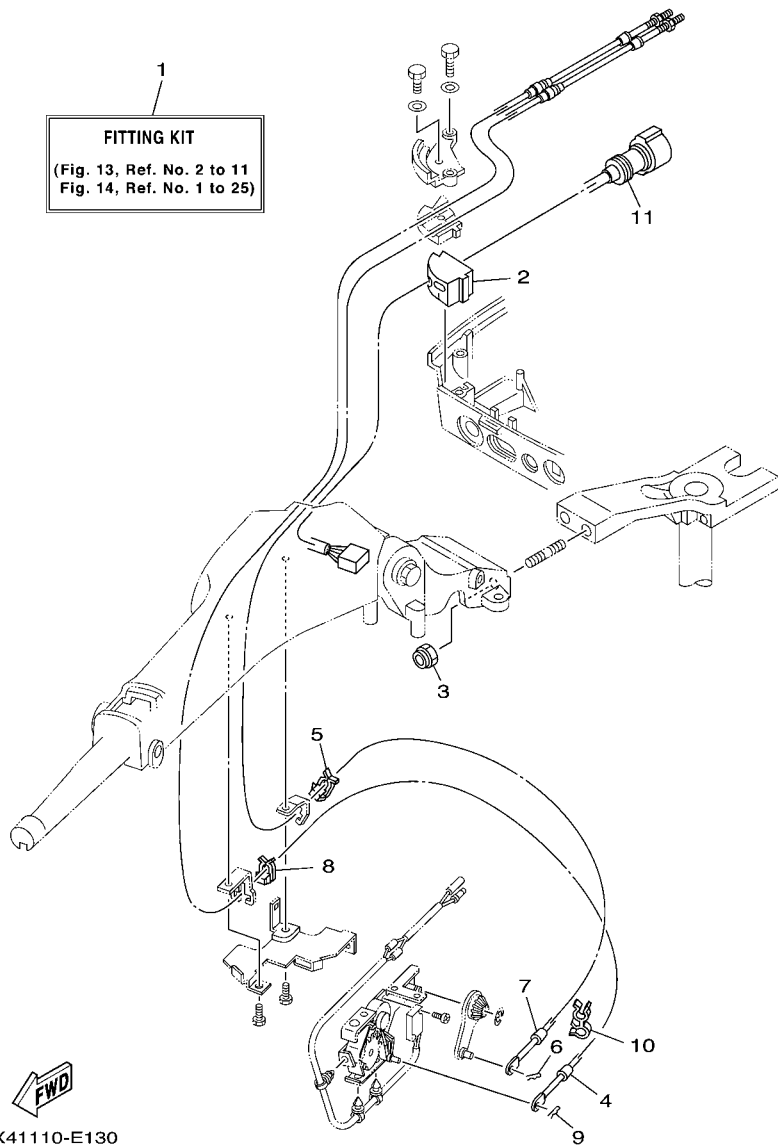
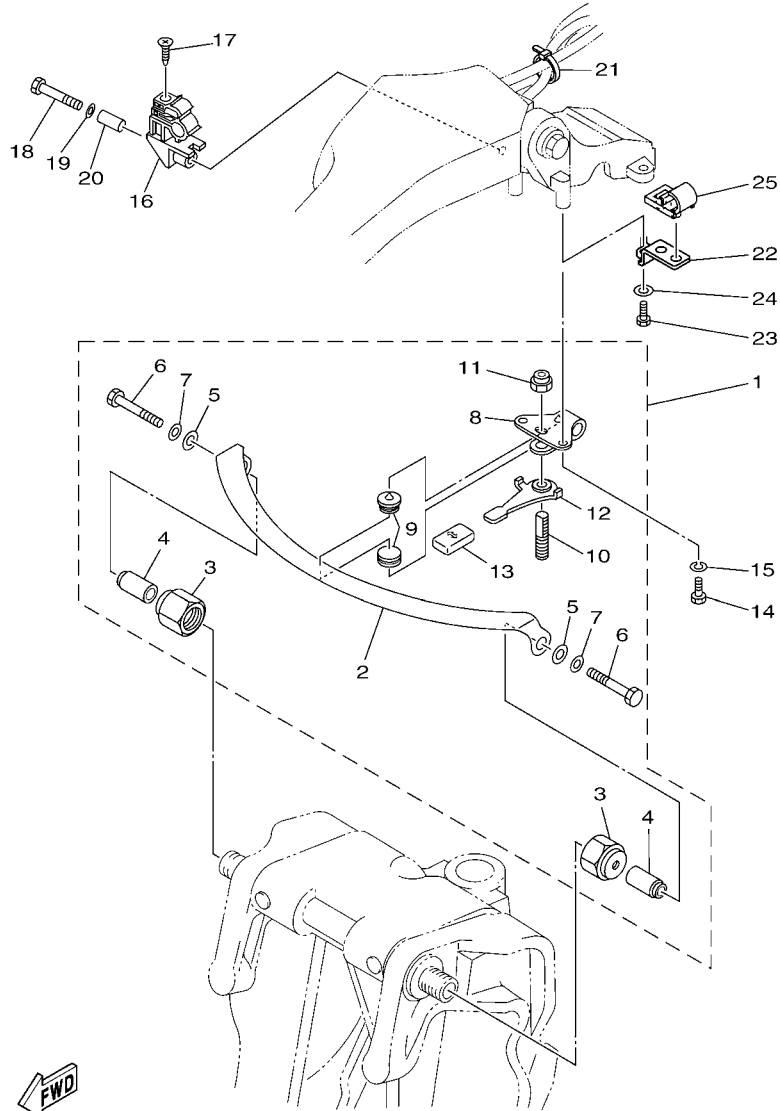

FIG. 13 FITTING KIT- 40, 50

REF. NO.	PART NO.	DESCRIPTION	6X41				REMARKS
1	6X4-42102-60	FITTING KIT	1				LM
2	6H4-42724-20	GROMMET	1				
3	90185-10051	NUT, SELF-LOCKING	2				
4	63D-48321-10	CABLE	1				
5	63D-48538-00	CLAMP, CABLE 1	1				
6	90468-10005	CLIP	1				
7	63D-26301-01	THROTTLE CABLE ASSY	1				
8	63D-48538-00	CLAMP, CABLE 1	1				
9	90468-10005	CLIP	1				
10	90464-09M42	CLAMP	1				
11	6X4-82586-00	EXT., WIRE HARNESS (L: 700MM)	1				



62XA100-E180

FIG. 14 FITTING KIT: STEERING FRICTION - 40, 50

REF. NO.	PART NO.	DESCRIPTION	6X41			REMARKS
1	63D-42508-00	STEERING FRICTION ASSY	1			
2	63D-42527-00	.PLATE, FRICTION	1			
3	63D-42546-00	.NUT	2			
4	63D-42541-00	.DAMPER	2			
5	90201-08M01	.WASHER, PLATE	2			
6	97095-08050	.BOLT	2			
7	92990-08600	.WASHER, PLATE	2			
8	63D-42526-00	.PLATE, FRICTION	1			
9	63D-42528-00	.PLATE, FRICTION	2			
10	63D-42562-00	.SHAFT, STEERING LOCK	1			
11	90185-10M01	.NUT, SELF-LOCKING	1			
12	63D-42561-00	.KNOB, STEERING LOCK	1			
13	682-43318-01	.COVER	1			
14	97095-06016	BOLT	2			
15	92995-06100	WASHER, SPRING	2			
16	63D-82361-00	CLAMP, CORD	1			
17	90161-06M00	SCREW, TAPPING	1			
18	97095-06035	BOLT	1			
19	92995-06600	WASHER	1			
20	90387-06M26	COLLAR	1			
21	90465-13M36	CLAMP	1			
22	63D-24364-10	STAY	1			
23	97095-06016	BOLT	1			
24	92995-06600	WASHER	1			
25	63D-24367-00	CLAMP, FUEL PIPE 2	1			

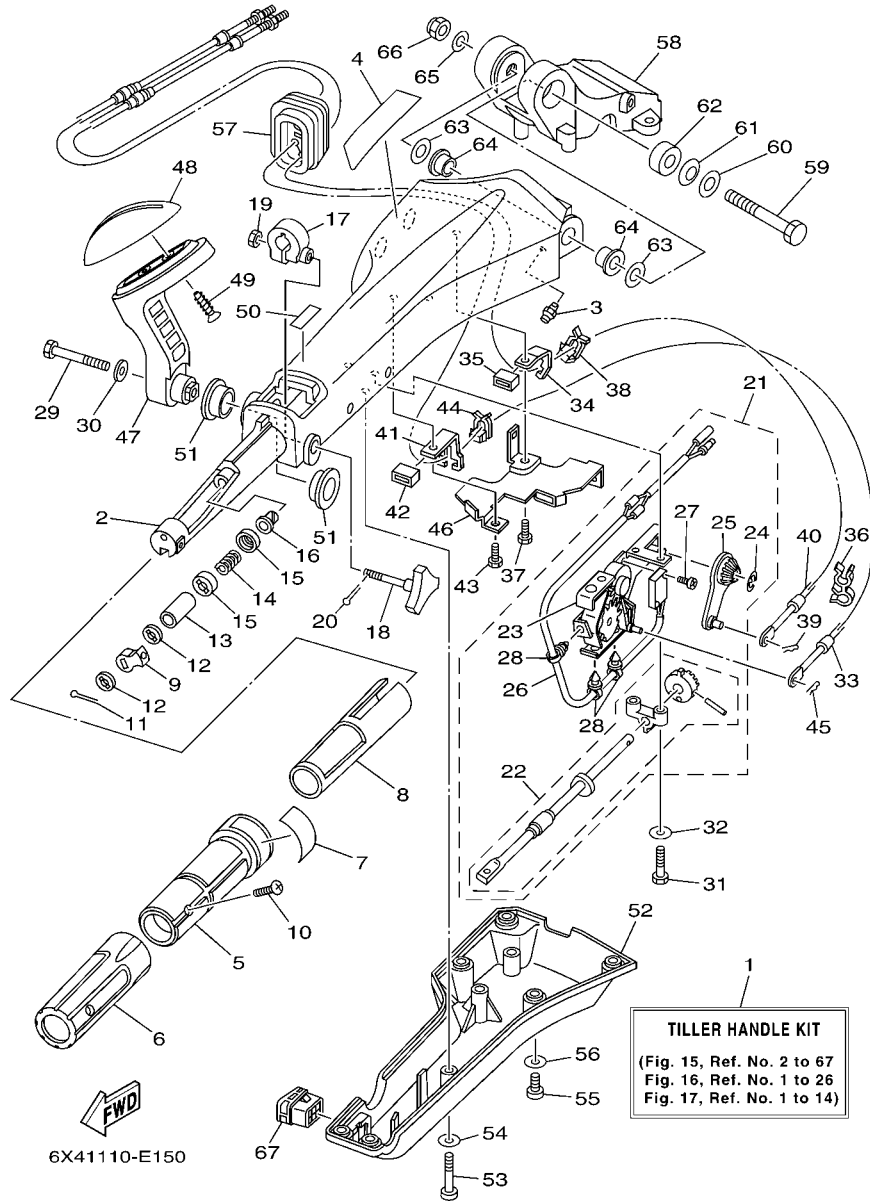

FIG. 15 TILLER HANDLE F25 COMPLETE 1

REF. NO.	PART NO.	DESCRIPTION	6X41				REMARKS
1	6X4-42103-00	TILLER HANDLE KIT	1				LM
2	6X4-42111-00-4D	HANDLE, STEERING	1				
3	93700-06M03	NIPPLE, GREASE	1				
4	6X4-48215-00	GRAPHIC	1				
5	6X4-42119-00	GRIP, STEERING HANDLE	1				
6	6X4-42177-00	RUBBER, HANDLE	1				
7	6X4-42137-00	INDICATOR, THROTTLE	1				
8	6X4-41291-00	BUSHING	1				
9	6X4-44139-00	COLLAR	1				
10	90142-05001	SCREW, COUNTERSUNK	1				
11	91490-20010	PIN, COTTER	1				
12	6X4-44177-00	WASHER	2				
13	6X4-42128-00	COLLAR, DISTANCE 1	1				
14	90501-23215	SPRING, COMPRESSION	1				
15	6X4-44188-00	WASHER	2				
16	90386-08032	BUSH	1				
17	63D-42126-00	FRICION, STEERING HANDLE GRIP	1				
18	6X4-48154-00	KNOB, THROTTLE	1				
19	95380-06600	NUT, HEXAGON	1				
20	91490-20010	PIN, COTTER	1				
21	6X4-44100-00	SHIFT LINK ASSY	1				
22	6X4-42115-00	.SHAFT, STEERING HANDLE	1				
23	6X4-44102-00	.SHIFT ASSIST ASSY.	1				
24	6X4-14137-00	.CLIP	1				
25	69W-48261-00	.ARM, THROTTLE	1				
26	6X4-82540-00	.NEUTRAL SWITCH ASSY	1				
27	6A5-48129-10	.SCREW 3	2				

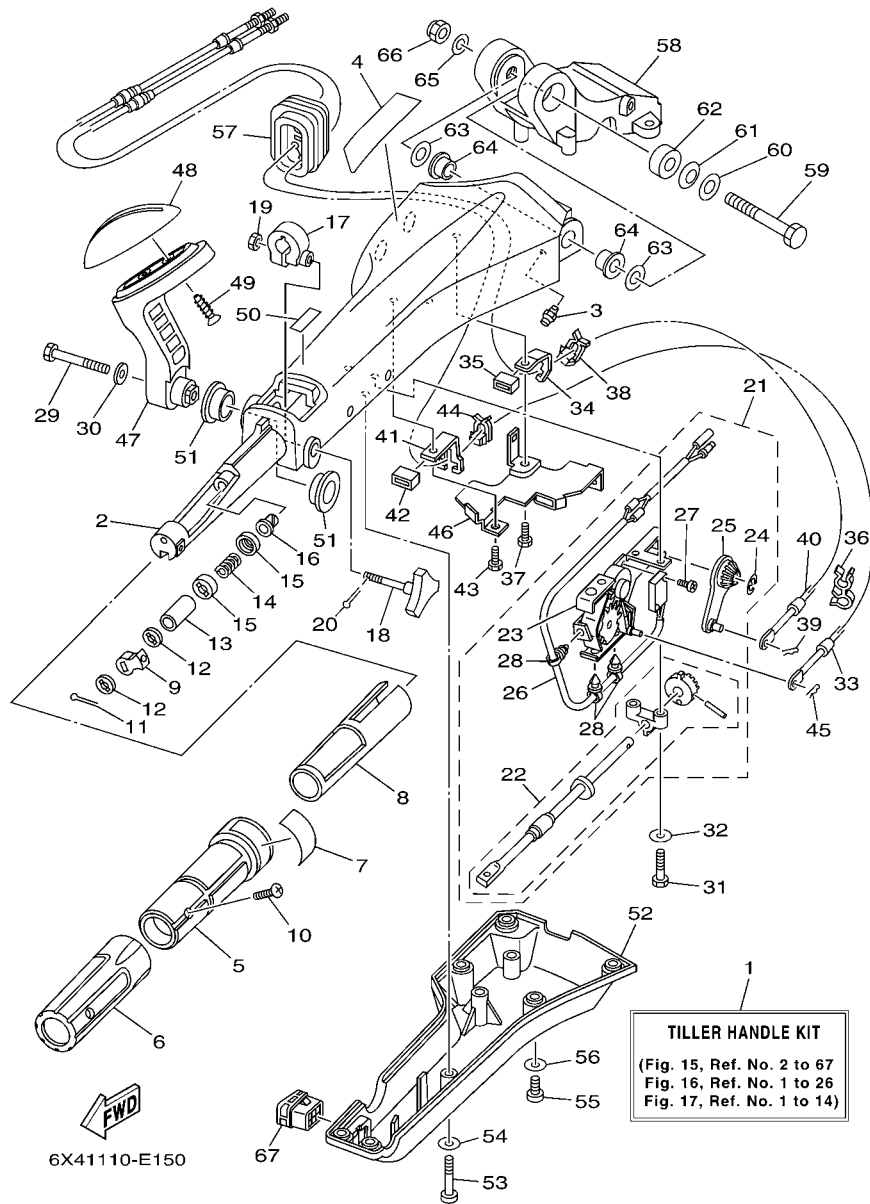

FIG. 15 TILLER HANDLE F25 COMPLETE 1

REF. NO.	PART NO.	DESCRIPTION	QTY	REMARKS
28	6X4-42821-00	.BAND, CLAMP	3	
29	97095-08040	BOLT	1	
30	92995-08600	WASHER	1	
31	97095-06030	BOLT	2	
32	92995-06600	WASHER	2	
33	6H1-48321-20	CABLE	1	
34	6X4-48538-00	CLAMP, CABLE 1	1	
35	6X4-26367-00	PROTECTOR	1	
36	90464-09M42	CLAMP	1	
37	97095-06014	BOLT	1	
38	63D-48538-00	CLAMP, CABLE 1	1	
39	90468-10005	CLIP	1	
40	6H3-48321-01	CABLE	1	
41	6X4-48538-10	CLAMP, CABLE 1	1	
42	6X4-26367-00	PROTECTOR	1	
43	97095-06014	BOLT	1	
44	63D-48538-00	CLAMP, CABLE 1	1	
45	90468-10005	CLIP	1	
46	6X4-42159-00	STAY	1	
47	6X4-44159-00-4D	HANDLE, GEAR SHIFT	1	
48	6X4-44173-00	LEVER, SHIFT CONTROL	1	
49	97780-60920	SCREW, TAPPING	2	
50	6G8-44191-00	INDICATOR, SHIFT	1	
51	90386-26MA3	BUSH	2	
52	6X4-42131-00	COVER, HANDLE STEERING	1	
53	97885-06040	SCREW, PAN HEAD	1	
54	92995-06600	WASHER	1	

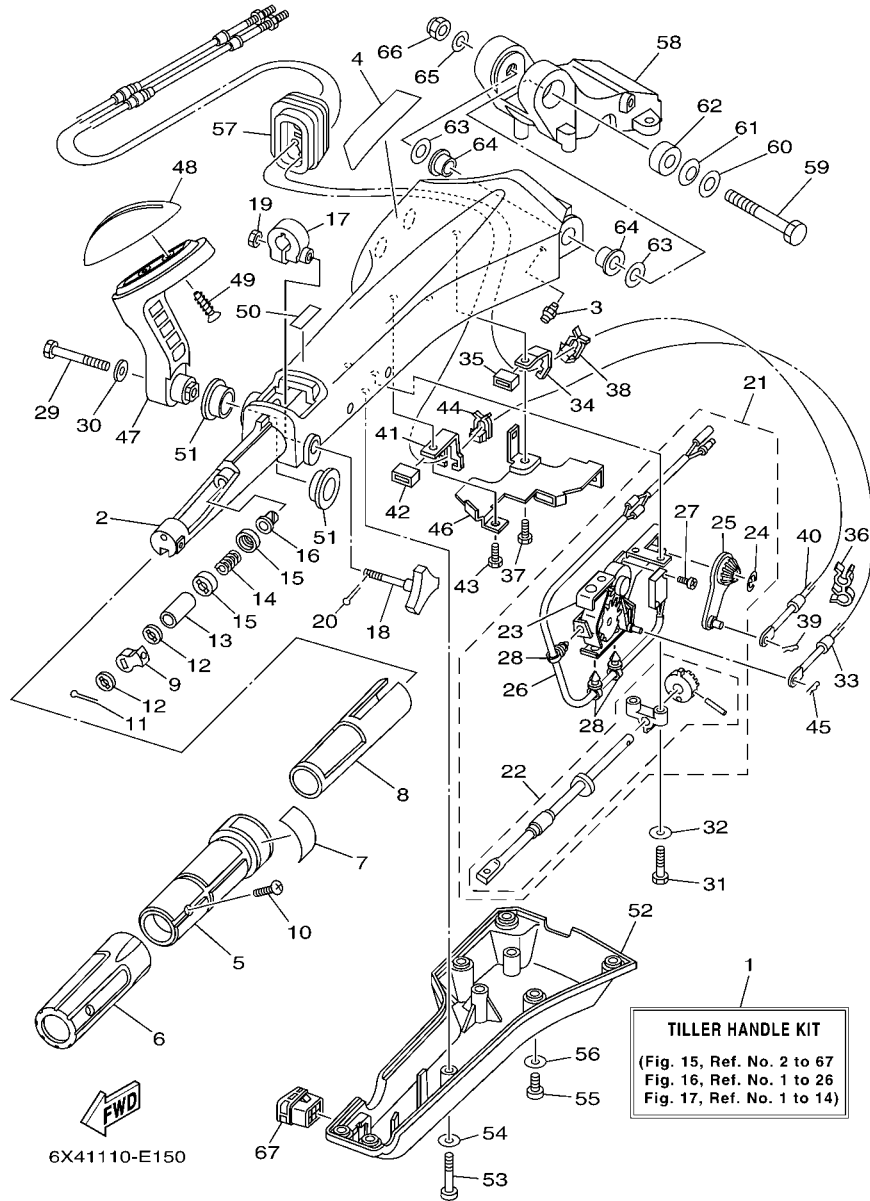
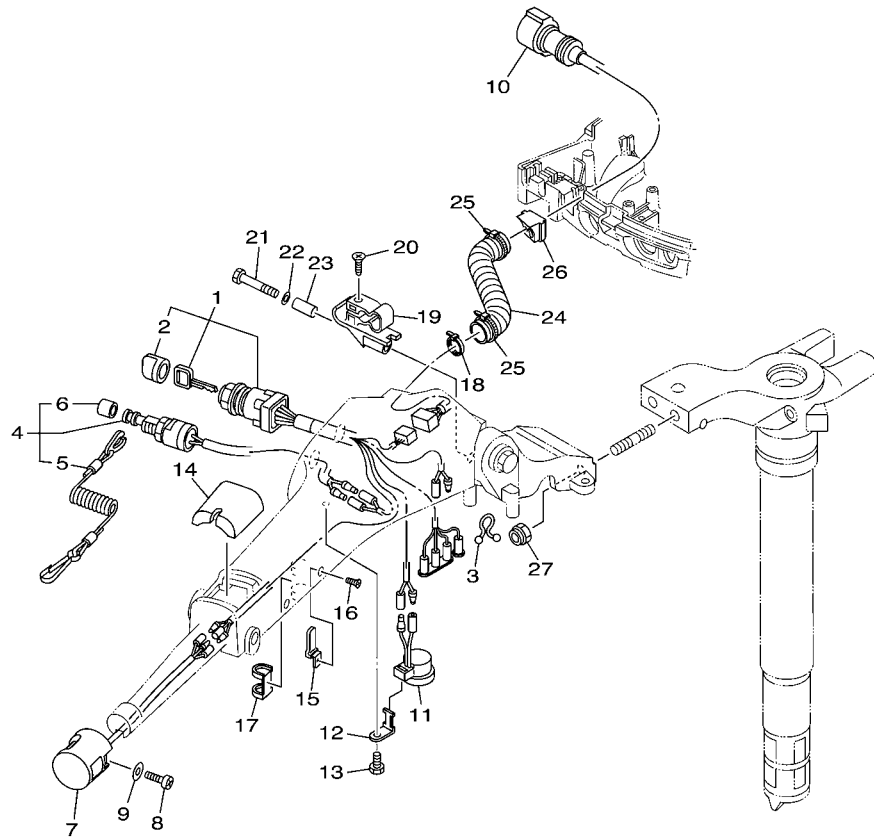

FIG. 15 TILLER HANDLE F25 COMPLETE 1

REF. NO.	PART NO.	DESCRIPTION	6X41				REMARKS
55	97885-06016	SCREW, PAN HEAD	6				
56	92995-06600	WASHER	6				
57	6X4-42725-00	GROMMET	1				
58	65W-42121-11-4D	BRACKET	1				
59	90101-12014	BOLT	1				
60	92990-12200	WASHER, PLAIN	1				
61	90206-12M22	WASHER, WAVE	1				
62	90387-12M02	COLLAR	1				
63	90201-12035	WASHER, PLATE	2				
64	90386-12003	BUSH	2				
65	92990-12600	WASHER, PLATE	1				
66	90185-12M12	NUT, SELF-LOCKING	1				
67	6X4-42728-10	CAP	1				



6X41110-E160

FIG. 16 TILLER HANDLE F25 COMPLETE 2

REF. NO.	PART NO.	DESCRIPTION	6X41				REMARKS
1	6X4-82510-00	MAIN SWITCH ASSY	1				
2	676-82577-00	.CAP, KEY	1				
3	90464-08M07	CLAMP	1				
4	69W-82575-00	ENGINE STOP SWITCH ASSY	1				
5	682-82556-00	.LANYARD, STOP SWITCH	1				
6	689-8257Y-00	.CAP	1				
7	6X4-82563-00	TRIM & TILT SWITCH ASSY	1				
8	97880-06016	SCREW, PAN HEAD	1				
9	92990-06600	WASHER, PLATE	1				
10	6X4-82586-10	EXT., WIRE HARNESS (L: 950MM)	1				
11	6X4-83383-00	BUZZER	1				
12	6X4-83386-00	STAY, BUZZER	1				
13	97095-06014	BOLT	1				
14	6X4-81942-00	COVER	1				
15	6X4-44554-00	PLATE	2				
16	90152-04015	SCREW, COUNTERSUNK	2				
17	6X4-42724-00	GROMMET	1				
18	90465-13M36	CLAMP	1				
19	62Y-82361-00	CLAMP, CORD	1				
20	90161-06M03	SCREW, TAPPING	1				
21	97095-06035	BOLT	1				
22	92995-06600	WASHER	1				
23	90387-06M26	COLLAR	1				
24	90447-22006	HOSE, WITH SPRING	1				
25	90465-13M24	CLAMP	2				
26	65W-42725-21	GROMMET	1				
27	90185-10051	NUT, SELF-LOCKING	2				

FIG. 17 TILLER HANDLE F25 COMPLETE 3

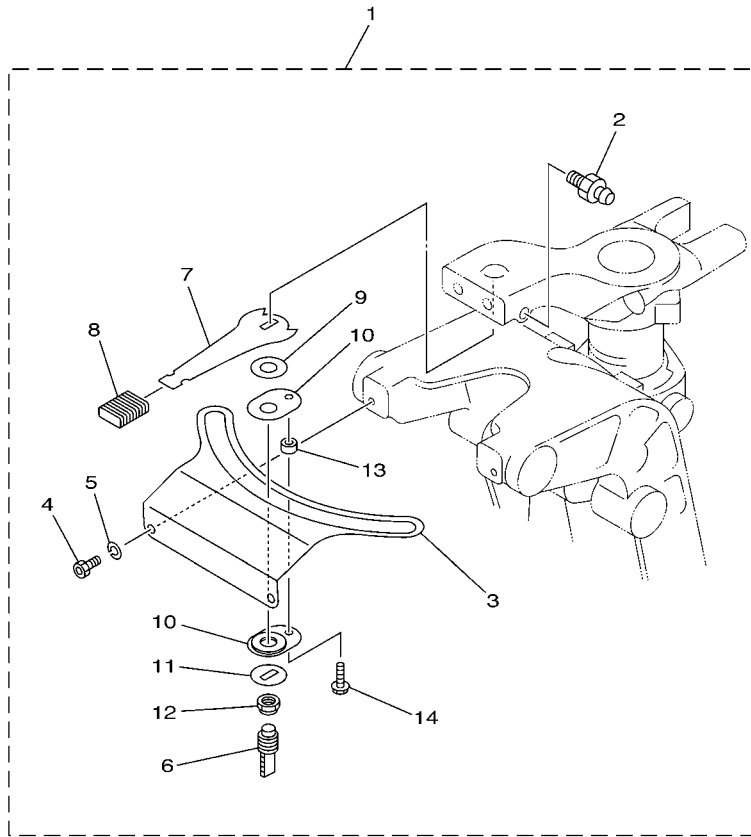

65W1010-2180

REF. NO.	PART NO.	DESCRIPTION	6X41				REMARKS
1	65W-42508-00	STEERING FRICTION ASSY	1				
2	93700-06M03	.NIPPLE, GREASE	1				
3	65W-42527-00	.PLATE, FRICTION	1				
4	90109-06M50	.BOLT	2				
5	92990-06100	.WASHER, SPRING	2				
6	65W-42562-00	.SHAFT, STEERING LOCK	1				
7	65W-42561-00	.KNOB, STEERING LOCK	1				
8	689-43633-00	.COVER, TILT LEVER	1				
9	90202-10M56	.WASHER, PLATE	1				
10	65W-42528-00	.PLATE, FRICTION	2				
11	90209-10M26	.WASHER	1				
12	90185-10M14	.NUT, SELF-LOCKING	1				
13	90387-05M11	.COLLAR	1				
14	97595-05516	.BOLT, WITH WASHER	1				

NUMERICAL INDEX

PART NO.	REF. NO.	PART NO.	REF. NO.	PART NO.	REF. NO.	PART NO.	REF. NO.	PART NO.	REF. NO.	PART NO.	REF. NO.
6X4-14137-00	1 - 24	6X4-42137-00	1 - 7	6X4-42725-00	15 - 57	67C-48321-10	6 - 4	6X4-82586-00	13 - 11	90201-08M01	14 - 5
	15 - 24		15 - 7	68V-42725-10	3 - 2		8 - 4	6X4-82586-10	6 - 11	90201-10M76	5 - 10
6X4-24364-00	3 - 18	6X4-42159-00	1 - 39		4 - 2	6H1-48321-10	10 - 4		16 - 10	90201-12035	1 - 56
	4 - 19		15 - 46	65W-42725-21	16 - 26	6H3-48321-10	11 - 6	6X4-82586-20	3 - 13		15 - 63
63D-24364-10	14 - 22	6X4-42177-00	1 - 6	62Y-42725-30	8 - 2	67G-48321-20	3 - 6		4 - 13	90202-10M56	7 - 9
63D-24367-00	3 - 17		15 - 6	6C5-42725-30	6 - 2		4 - 6	6X4-82586-30	10 - 11		9 - 9
	4 - 18	63D-42508-00	14 - 1	6H3-42725-30	11 - 2	6H1-48321-20	15 - 33		11 - 13		17 - 9
	14 - 25	65W-42508-00	17 - 1	6X4-42728-10	1 - 60	63D-48538-00	3 - 7	6X4-83383-00	2 - 10	90206-12M22	1 - 54
69W-26301-00	6 - 7	6C5-42508-00	7 - 1		15 - 67		3 - 10		16 - 11		15 - 61
	8 - 7	692-42508-01	12 - 1	6X4-42735-00	3 - 16		4 - 7	6X4-83386-00	2 - 11	90209-10M26	7 - 11
63D-26301-01	13 - 7	67C-42508-03	9 - 1		4 - 17		4 - 10		16 - 12		9 - 11
6H1-26301-01	10 - 7	67G-42508-10	5 - 1	6X4-42821-00	1 - 28		6 - 5	6G5-83557-00	3 - 15		17 - 11
6H3-26301-01	11 - 9	692-42515-01	12 - 6		15 - 28		6 - 8	6K3-83557-00	4 - 16	90386-08032	1 - 16
67G-26301-10	3 - 9	663-42518-00	12 - 2	682-43318-01	5 - 8		8 - 5	90101-12014	1 - 52		15 - 16
	4 - 9	67C-42525-00	7 - 4		14 - 13		8 - 8		15 - 59	90386-12003	1 - 57
6X4-26367-00	1 - 34		9 - 4	689-43633-00	7 - 8		10 - 5	90109-06M50	17 - 4		15 - 64
	1 - 37	63D-42526-00	14 - 8		9 - 8		10 - 8	90109-06M88	7 - 3	90386-26MA3	1 - 44
	15 - 35	6X4-42526-00	5 - 11		17 - 8		11 - 7		9 - 3		10 - 15
	15 - 42	63D-42527-00	5 - 6	6X4-44100-00	1 - 21		11 - 10	90116-10031	4 - 5		15 - 51
6X4-41291-00	1 - 8		14 - 2		15 - 21		13 - 5		10 - 3	90387-05M05	7 - 12
	15 - 8	65W-42527-00	17 - 3	6X4-44102-00	1 - 23		13 - 8		11 - 4		9 - 12
6X4-42101-00	1 - 1	6C5-42527-00	7 - 2		15 - 23		15 - 38	90116-10175	3 - 4	90387-05M11	7 - 14
6X4-42102-00	3 - 1	67C-42527-03	9 - 2	6X4-44139-00	1 - 9		15 - 44	90119-08M74	5 - 2		9 - 14
6X4-42102-10	4 - 1	63D-42528-00	5 - 17		15 - 9	6X4-48538-00	1 - 33	90142-05001	1 - 10		17 - 13
6X4-42102-20	6 - 1		14 - 9	6X4-44159-00-4D	1 - 40		15 - 34		15 - 10	90387-06M26	14 - 20
6X4-42102-30	8 - 1	65W-42528-00	7 - 10		15 - 47	6X4-48538-10	1 - 36	90152-04015	2 - 15		16 - 23
6X4-42102-40	10 - 1		9 - 10	6X4-44159-10-4D	10 - 12		15 - 41		16 - 16	90387-12M02	1 - 55
6X4-42102-50	11 - 1		17 - 10	6X4-44173-00	1 - 41	6X4-81860-00	4 - 14	90161-06M00	14 - 17		15 - 62
6X4-42102-60	13 - 1	663-42528-00	12 - 3		10 - 13		6 - 12	90161-06M03	16 - 20	90447-22006	16 - 24
6X4-42103-00	15 - 1	63D-42541-00	14 - 4		15 - 48	6X4-81942-00	2 - 13	90175-06003	12 - 5	90447-22007	3 - 14
6X4-42111-00-4D	1 - 2	67G-42541-00	5 - 4	6X4-44177-00	1 - 12		16 - 14	90185-08057	5 - 14		4 - 15
	15 - 2	67G-42541-10	5 - 7		15 - 12	62Y-82361-00	16 - 19		12 - 8	90464-08M07	2 - 3
6X4-42115-00	1 - 22	63D-42546-00	14 - 3	6X4-44188-00	1 - 15	63D-82361-00	14 - 16	90185-10051	3 - 5		16 - 3
	15 - 22	67G-42546-00	5 - 5		15 - 15	6X4-82510-00	2 - 1		4 - 4	90464-09M42	3 - 12
6X4-42119-00	1 - 5	63D-42561-00	14 - 12	6G8-44191-00	1 - 43		16 - 1		6 - 3		4 - 12
	15 - 5	65W-42561-00	17 - 7		15 - 50	6X4-82540-00	1 - 26		8 - 3		6 - 10
6X4-42121-00-4D	4 - 3	67C-42561-00	7 - 7	6X4-44554-00	2 - 14		15 - 26		10 - 19		8 - 10
	10 - 2		9 - 7		16 - 15	682-82556-00	2 - 5		11 - 5		10 - 10
	11 - 3	67G-42561-00	5 - 15	6A5-48129-10	1 - 27		16 - 5		13 - 3		11 - 12
6X4-42121-10-4D	3 - 3	63D-42562-00	14 - 10		15 - 27	6X4-82563-00	2 - 7		16 - 27		13 - 10
65W-42121-11-4D	15 - 58	65W-42562-00	17 - 6	6X4-48154-00	1 - 18		16 - 7	90185-10M01	14 - 11		15 - 36
63D-42121-22-4D	1 - 51	67C-42562-00	7 - 6		15 - 18	69W-82575-00	2 - 4	90185-10M14	5 - 9	90465-13M24	3 - 21
63D-42126-00	1 - 17		9 - 6	6X4-48215-00	1 - 4		16 - 4		7 - 13		4 - 22
	15 - 17	67G-42562-00	5 - 16		15 - 4	676-82577-00	2 - 2		9 - 13		16 - 25
6X4-42128-00	1 - 13	6X4-42724-00	2 - 16	69W-48261-00	1 - 25		16 - 2		17 - 12	90465-13M30	3 - 22
	15 - 13		16 - 17		15 - 25	689-8257Y-00	2 - 6	90185-12M12	1 - 59		4 - 23
6X4-42131-00	1 - 45	6H4-42724-20	13 - 2	6H3-48321-01	15 - 40		16 - 6		15 - 66	90465-13M36	6 - 13
	15 - 52	6X4-42725-00	1 - 50	63D-48321-10	13 - 4	6X4-82586-00	8 - 11	90201-08M01	5 - 3		8 - 12

NUMERICAL INDEX

PART NO.	REF. NO.	PART NO.	REF. NO.	PART NO.	REF. NO.	PART NO.	REF. NO.	PART NO.	REF. NO.	PART NO.	REF. NO.
90465-13M36	10 - 18	92995-06600	15 - 54								
	11 - 14		15 - 56								
	14 - 21		16 - 22								
	16 - 18	92995-08600	1 - 30								
90468-10005	3 - 8		5 - 13								
	3 - 11		10 - 17								
	4 - 8		15 - 30								
	4 - 11	93700-06M03	1 - 3								
	6 - 6		15 - 3								
	6 - 9		17 - 2								
	8 - 6	95380-05600	7 - 17								
	8 - 9		9 - 17								
	10 - 6	95380-06600	1 - 19								
	10 - 9		15 - 19								
	11 - 8	97080-06035	12 - 4								
	11 - 11	97095-05020	7 - 15								
	13 - 6		9 - 15								
	13 - 9	97095-06014	1 - 35								
	15 - 39		1 - 38								
	15 - 45		2 - 12								
90501-23215	1 - 14		15 - 37								
	15 - 14		15 - 43								
91490-20010	1 - 11		16 - 13								
	1 - 20	97095-06016	3 - 19								
	15 - 11		4 - 20								
	15 - 20		14 - 14								
92990-06100	7 - 5		14 - 23								
	9 - 5	97095-06030	1 - 31								
	17 - 5		15 - 31								
92990-06600	2 - 9	97095-06035	14 - 18								
	16 - 9		16 - 21								
92990-08600	12 - 7	97095-08025	5 - 12								
	14 - 7	97095-08040	1 - 29								
92990-12200	1 - 53		10 - 16								
	15 - 60		15 - 29								
92990-12600	1 - 58	97095-08050	14 - 6								
	15 - 65	97595-05516	17 - 14								
92995-05600	7 - 16	97780-60920	1 - 42								
	9 - 16		10 - 14								
92995-06100	14 - 15		15 - 49								
92995-06600	1 - 32	97880-06016	2 - 8								
	1 - 47		16 - 8								
	1 - 49	97885-06016	1 - 48								
	3 - 20		15 - 55								
	4 - 21	97885-06040	1 - 46								
	14 - 19		15 - 53								
	14 - 24										
	15 - 32										