

PARTS CATALOGUE

RIGGING-STEERING



1U601-10SEA

()

RIGGING-STEERING
PARTS CATALOGUE

©2020 by Yamaha Motor Co., Ltd.
1st edition, October 2020

All rights reserved.

Any reprinting or unauthorized use
without the written permission of

Yamaha Motor Co., Ltd.

is expressly prohibited.

Printed in Japan.

FOREWORD

This Parts Catalogue is related to the parts for the model(s) on the cover page. When you are ordering replacement parts, please refer to this Parts Catalogue and quote both part numbers and part names correctly.

1. Modifications or additions which have been made after the issue of the Parts Catalogue will be announced in the Parts News.
It is advisable that you make the necessary corrections to the Parts Catalogue according to the Parts News.

2. Abbreviations

The following abbreviations are used in this Parts Catalogue.

“UR” Use specified parts number.

“UN” Use as many as needed.

“AP” Alternate Parts

“LM” Locally Made (Parts need to be ordered locally)

“F#” Frame No. (Applicable machine No.)

“O/S” Over Size

3. The number of components for assembly

- Parts, which are to be supplied in an assembly, are listed with a dot (.) in front of the part name as shown below.
- The numeral appearing to the right of each component part indicates the quantity of parts for each assembly unit.

PART NO.	DESCRIPTION	Q'TY	REMARKS
2F5-83310-60	FRONT FLASHER LIGHT ASSY	2	
115-83311-60	.BULB (6V-18W)	1	

4. Applicable colours of graphics are represented in the “REMARKS” as shown below.

PART NO.	DESCRIPTION	Q'TY	REMARKS
2N4-24110-00-X5	FUEL TANK COMP.	2	MXR
3J1-24240-10	.GRAPHIC, FUEL TANK	1	FOR MXR

5. Note that the illustrations for reference in finding parts numbers are not to be used for assembling. When assembling, please use the applicable service manual.

6. The asterisk (*) before a reference number indicates modified items after the first edition.

CONTENTS

BASE HANDLE - ALL.....	1
BASE HANDLE ELECTRICAL 1.....	4
BASE HANDLE ELECTRICAL 2.....	5
TILLER HANDLE KIT 1.....	6
TILLER HANDLE KIT 2.....	9
FITTING KIT 1.....	10
FITTING KIT 2.....	11
FITTING KIT 3.....	12
FITTING KIT 4.....	13
FITTING KIT 5.....	14
STEERING FRICTION 1.....	15
STEERING FRICTION 2.....	16
STEERING FRICTION 3.....	17
STEERING FRICTION 4.....	18
STEERING FRICTION 5.....	19
STEERING FRICTION 6.....	20
STEERING FRICTION 7.....	21
STEERING FRICTION 8.....	22
STEERING FRICTION 9.....	23

INDEX

NUMERICAL INDEX.....	24
----------------------	----

Application Model

PART NO. / PART NAME																	
FIG.NO.																	
FOR USA, CANADA										FOR EUROPE, OCEANIA							
MODEL CODE	MODEL NAME	SERIAL NO.	6X4-42103-5C TILLER HANDLE KIT	6X4-42103-0E TILLER HANDLE KIT	6X4-42102-H2 FITTING KIT	6X4-42102-J2 FITTING KIT	6X4-42102-23 FITTING KIT	6X4-42102-71 FITTING KIT	6X4-42102-E1 FITTING KIT	6X4-42102-K1 FITTING KIT	6X4-42103-6A TILLER HANDLE KIT	6X4-42102-C2 FITTING KIT	6X4-42102-92 FITTING KIT	6X4-42102-82 FITTING KIT	6X4-42102-F1 FITTING KIT	6X4-42102-L1 FITTING KIT	6X4-42102-G2 FITTING KIT
			FIG.1, 2	FIG.4, 5, 15	FIG.6, 11	FIG.6, 11	FIG.7, 12	FIG.8, 13	FIG.9, 18	FIG.9, 19	FIG.1, 3	FIG.6, 11	FIG.7, 12	FIG.8, 13	FIG.9, 18	FIG.9, 19	FIG.10, 11
6BPD	F25A-2020	6BPK-1040530-		*													
6EK7	F115B F115B-2020	6EK-1079793-	*		*						*	*					
6FN6	VF115A-2020	6FN-1018497-	*		*						*	*					
6EM6	F130A F130A-2020	6EM-1008666-	*		*						*	*					
6C1H	F50H F50B-2020	6C1-1087664-	*				*				*		*				
6C5H	F60F F60B-2020	6C5-1094064-	*				*				*		*				
6C2H	FT50J T50B-2020	6C2-1029586-	*				*				*		*				
6C6H	FT60G T60B-2020	6C6-1036831-	*				*				*		*				
6CJB	F70A F70A-2020	6CJ-1090228-	*				*				*		*				
6BTE	F30B F30A-2020	6BTK-1002369-	*					*			*			*			
6BGE	F40F F40A-2020	6BGK-1008263-	*					*			*			*			
6HY2	F20G F20B-2020	6HYK-1004694-	*							*	*					*	
6FM4	F25G F25C,T25C-2020	6FMK-1033598-	*						*		*				*		
6HW4	F75B-2020	6HW-1001278-	*			*					*						*
6HV4	F80D	6HV-1002426-									*						*
6FP4	F90B-2020	6FP-1022145-	*			*					*						*
6HK3	VF90A-2020	6HK-1003925-	*			*					*						*
6HJ4	F100F	6HJ-1005716-									*						*
6JX1	F75F	6JX-1000001-									*						*
6JY1	F100G	6JY-1000001-									*						*

6X4 TILLER HANDLE KIT (F20B-F130A)

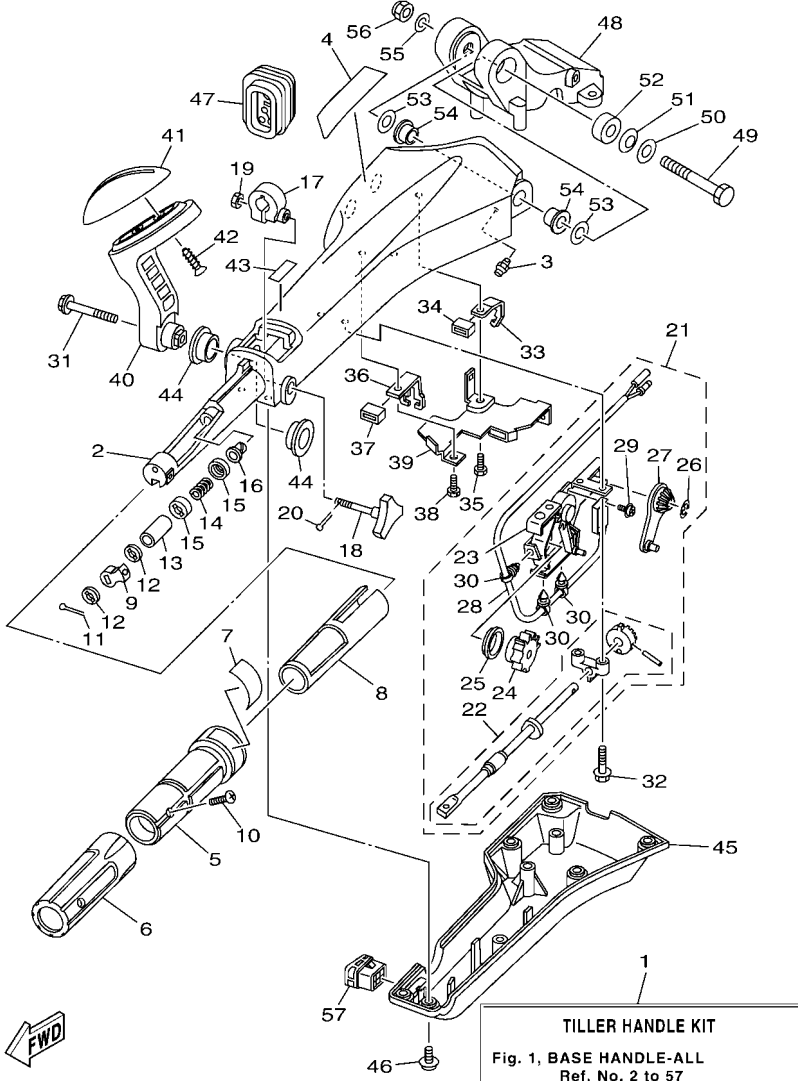

601S10S-T010

FIG. 1 BASE HANDLE - ALL

REF. NO.	PART NO.	DESCRIPTION	601S				REMARKS
1	6X4-42103-5C	TILLER HANDLE KIT	1				LM FOR USA,CAN
	6X4-42103-6A	TILLER HANDLE KIT	1				LM FOR EUR,OCE
2	6X4-42111-02-8D	HANDLE, STEERING	1				
3	93700-06002	NIPPLE, GREASE	1				
4	6X4-48215-00	GRAPHIC	1				
5	6X4-42119-01	GRIP, STEERING HANDLE	1				
6	6X4-42177-01	RUBBER, HANDLE	1				
7	6X4-42137-00	INDICATOR, THROTTLE	1				
8	6X4-41291-00	BUSHING	1				
9	6X4-44139-01	COLLAR	1				
10	90152-05007	SCREW, COUNTERSUNK	1				
11	91490-20010	PIN. COTTER	1				
12	6X4-44177-00	WASHER	2				
13	6X4-42128-00	COLLAR, DISTANCE 1	1				
14	90501-23215	SPRING, COMPRESSION	1				
15	6X4-44188-00	WASHER	2				
16	90386-08032	BUSH	1				
17	63D-42126-00	FRICTION, STEERING HANDLE GRIP	1				
18	6X4-48154-00	KNOB, THROTTLE	1				
19	95380-06600	NUT, HEXAGON	1				
20	91490-20010	PIN. COTTER	1				
21	6X4-44100-01	SHIFT LINK ASSY	1				
22	6X4-42115-00	.SHAFT, STEERING HANDLE	1				
23	6X4-44102-00	.SHIFT ASSIST ASSY.	1				
24	6X4-47731-01	.GEAR, DRIVE	1				
25	6X4-44132-00	.BUSHING	1				
26	6X4-14137-00	.CLIP	1				

6X4 TILLER HANDLE KIT (F20B-F130A)

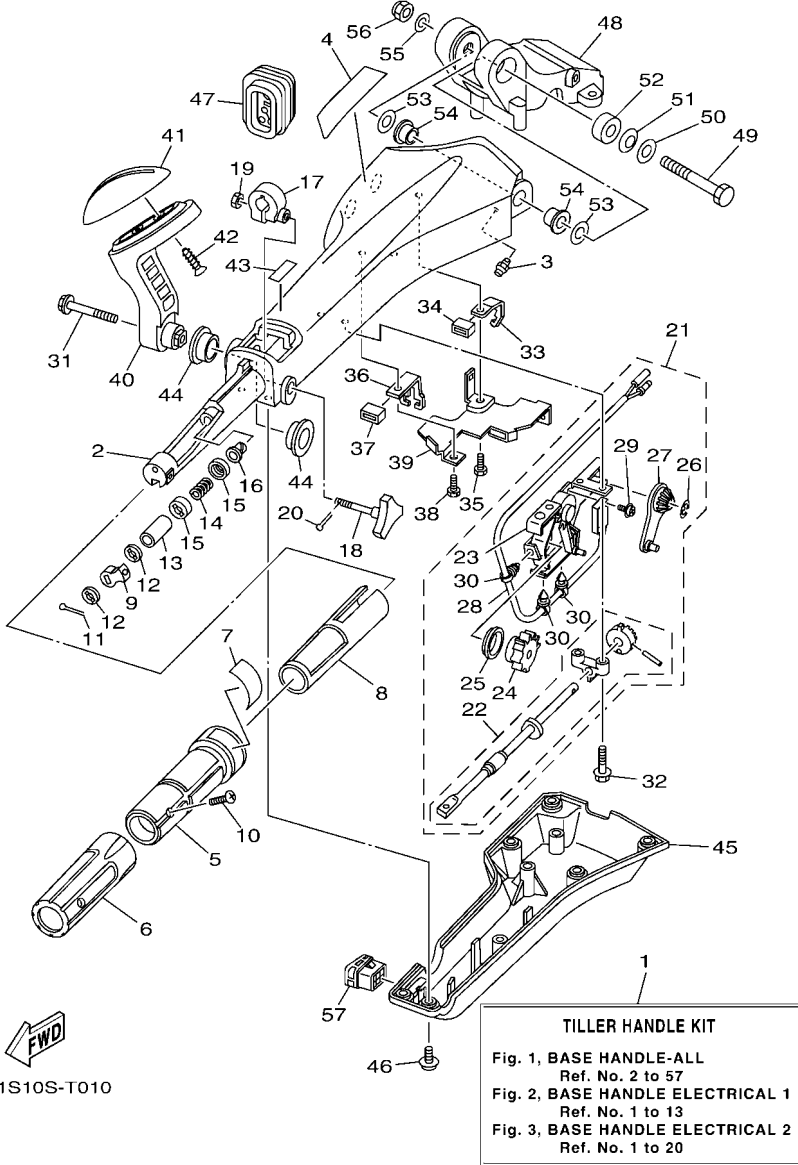
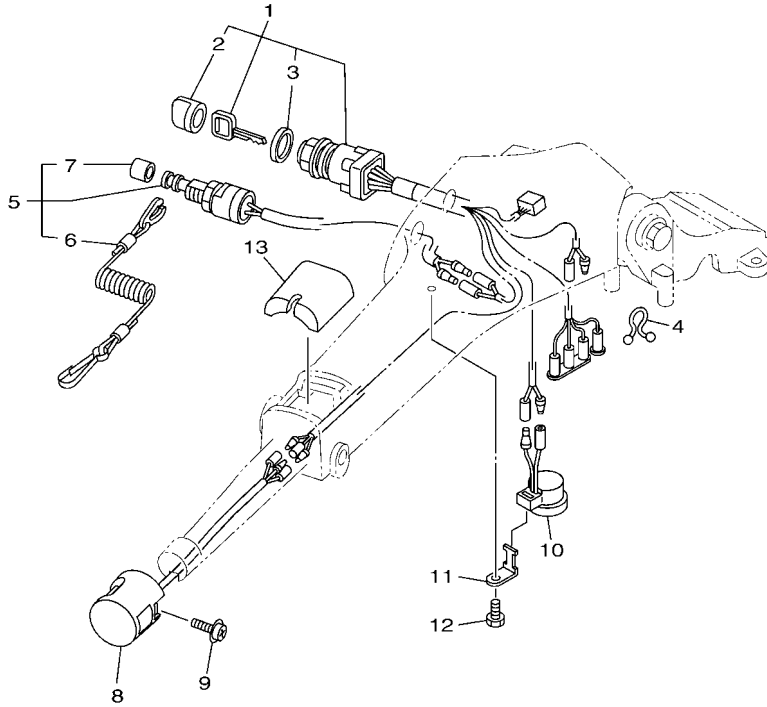

FIG. 1 BASE HANDLE - ALL

REF. NO.	PART NO.	DESCRIPTION	601S				REMARKS
27	6X4-48261-00	.ARM, THROTTLE	1				
28	6X4-82540-00	.NEUTRAL SWITCH ASSY	1				
29	703-48129-00	.SCREW 3	2				
30	6X4-42821-00	.BAND, CLAMP	3				
31	97E95-08540	BOLT, HEXAGON W/W DEEP RECESS	1				
32	97E95-06530	BOLT, HEXAGON W/W DEEP RECESS	2				
33	6X4-48538-00	CLAMP, CABLE 1	1				
34	6X4-26367-01	PROTECTOR	1				
35	97D95-06014	BOLT, HEXAGON DEEP RECESS	1				
36	6X4-48538-10	CLAMP, CABLE 1	1				
37	6X4-26367-01	PROTECTOR	1				
38	97D95-06014	BOLT, HEXAGON DEEP RECESS	1				
39	6X4-42159-00	STAY	1				
40	6X4-44159-A0-8D	HANDLE, GEAR SHIFT	1				
41	6X4-44173-00	LEVER, SHIFT CONTROL	1				
42	97780-60920	SCREW, TAPPING	2				
43	6G8-44191-00	INDICATOR, SHIFT	1				
44	90386-26MA3	BUSH	2				
45	6X4-42131-01	COVER, HANDLE STEERING	1				
	6X4-42131-11	COVER, HANDLE STEERING	1				FOR USA,CAN
46	97985-06216	SCREW, WITH WASHER	6				FOR EUR,OCE
47	6X4-42725-01	GROMMET	1				
48	63D-42121-22-8D	BRACKET	1				
49	90101-12014	BOLT	1				
50	92990-12200	WASHER, PLAIN	1				
51	90206-12M22	WASHER, WAVE	1				
52	90387-12M02	COLLAR	1				

6X4 TILLER HANDLE KIT
(F20B-F130A FOR USA, CANADA)



601S10S-T020

FIG. 2 BASE HANDLE ELECTRICAL 1

REF. NO.	PART NO.	DESCRIPTION	601S				REMARKS
1	6X4-82510-02	MAIN SWITCH ASSY	1				
2	676-82577-01	.CAP, KEY	1				
3	703-82532-00	.CAP	1				
4	90464-08M07	CLAMP	1				
5	69W-82575-00	ENGINE STOP SWITCH ASSY	1				
6	682-82556-00	.LANYARD, STOP SWITCH	1				
7	689-8257Y-00	.CAP	1				
8	6X4-82563-01	TRIM & TILT SWITCH ASSY	1				
9	97980-06216	SCREW, WITH WASHER	1				
10	6X4-83383-00	BUZZER	1				
11	6X4-83386-00	STAY, BUZZER	1				
12	97D95-06014	BOLT, HEXAGON DEEP RECESS	1				
13	6X4-81942-01	COVER	1				

**6X4 TILLER HANDLE KIT
(F20G-F130A FOR EUROPE, OCEANIA)**

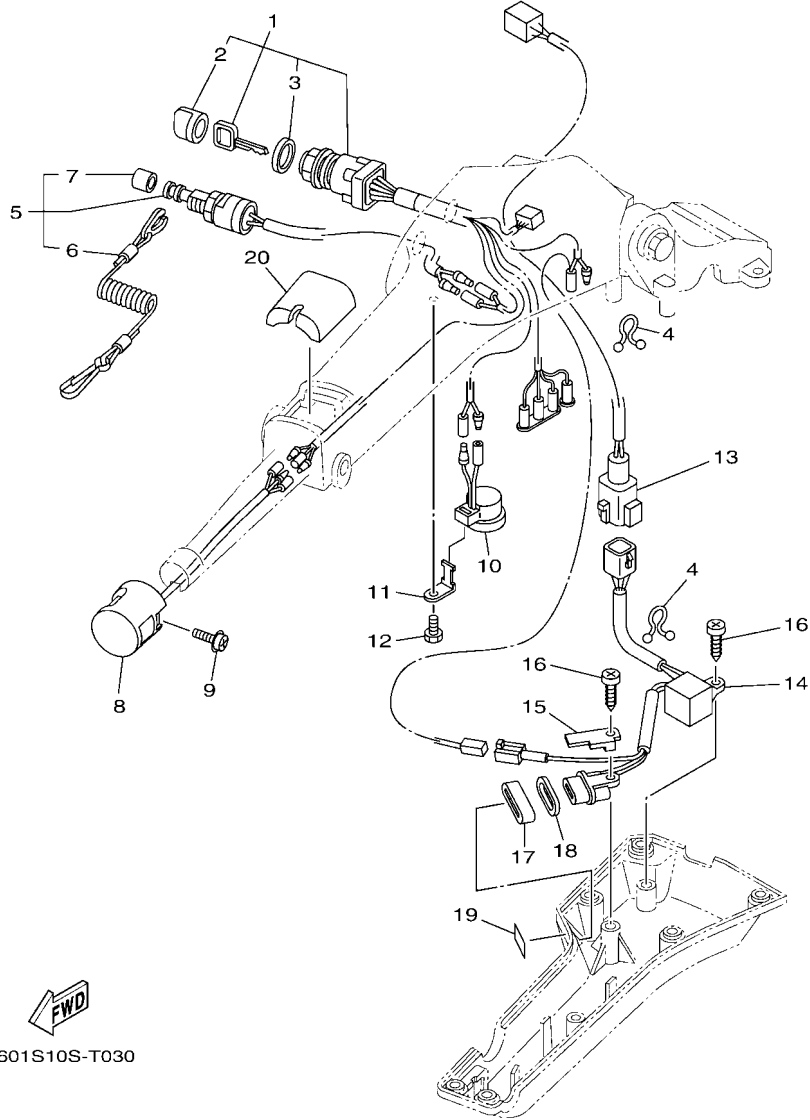

601S10S-T030

FIG. 3 BASE HANDLE ELECTRICAL 2

REF. NO.	PART NO.	DESCRIPTION	601S				REMARKS
1	6X4-82510-42	MAIN SWITCH ASSY	1				
2	676-82577-01	.CAP, KEY	1				
3	703-82532-00	.CAP	1				
4	90464-08M07	CLAMP	2				
5	69W-82575-00	ENGINE STOP SWITCH ASSY	1				
6	682-82556-00	.LANYARD, STOP SWITCH	1				
7	689-8257Y-00	.CAP	1				
8	6X4-82563-01	TRIM & TILT SWITCH ASSY	1				
9	97980-06216	SCREW, WITH WASHER	1				
10	6X4-83383-00	BUZZER	1				
11	6X4-83386-00	STAY, BUZZER	1				
12	97D95-06014	BOLT, HEXAGON DEEP RECESS	1				
13	6X4-83653-20	WIRE, LEAD (L:700MM)	1				
14	6C5-84301-00	PILOT LIGHT ASSY 1	1				
15	6X4-44114-00	STOPPER	1				
16	97780-60620	SCREW, TAPPING	2				
17	6X4-42727-01	GROMMET	1				
18	6H4-83589-00	GASKET	1				
19	6X4-85415-00	MARK, SIGNAL LAMP	1				
20	6X4-81942-01	COVER	1				

6X4 TILLER HANDLE KIT (F25A)

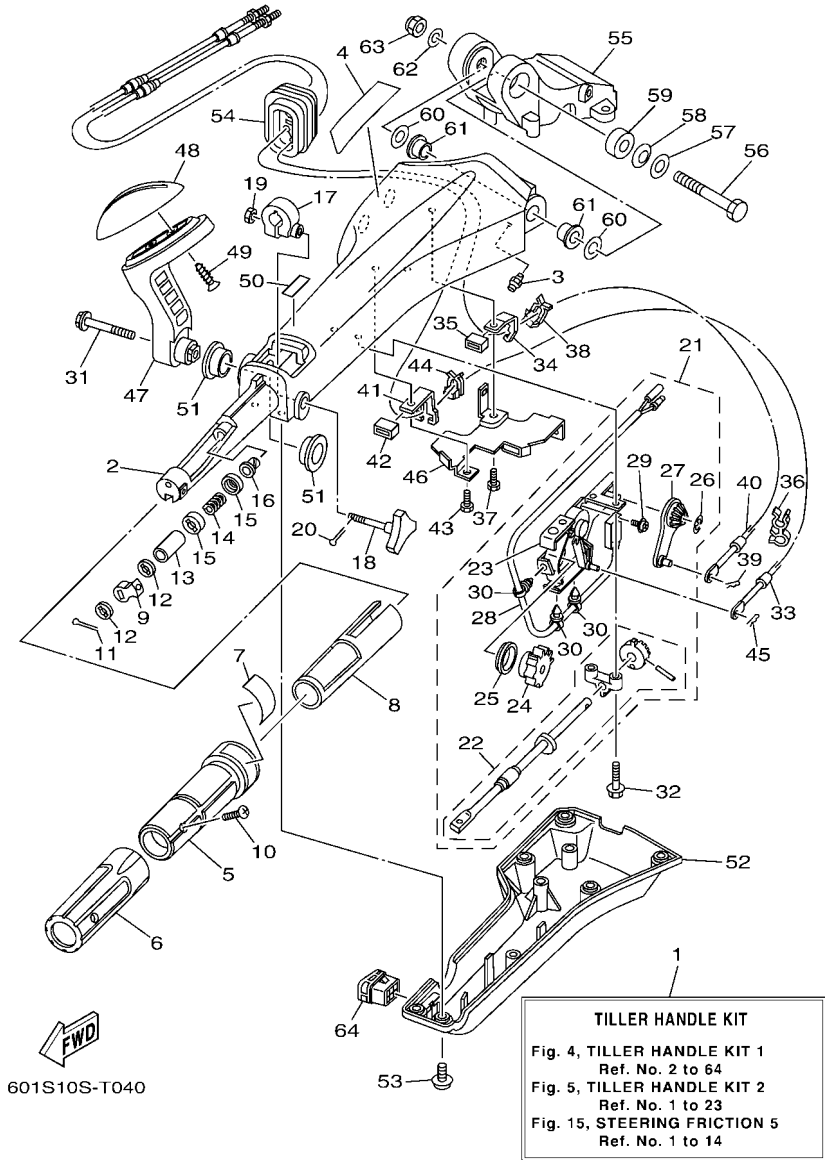

FIG. 4 TILLER HANDLE KIT 1

REF. NO.	PART NO.	DESCRIPTION	601S				REMARKS
1	6X4-42103-0E	TILLER HANDLE KIT	1				LM FOR USA,CAN
2	6X4-42111-02-4D	HANDLE, STEERING	1				
3	93700-06002	NIPPLE, GREASE	1				
4	6X4-48215-00	GRAPHIC	1				
5	6X4-42119-01	GRIP, STEERING HANDLE	1				
6	6X4-42177-01	RUBBER, HANDLE	1				
7	6X4-42137-00	INDICATOR, THROTTLE	1				
8	6X4-41291-00	BUSHING	1				
9	6X4-44139-01	COLLAR	1				
10	90152-05007	SCREW, COUNTERSUNK	1				
11	91490-20010	PIN. COTTER	1				
12	6X4-44177-00	WASHER	2				
13	6X4-42128-00	COLLAR, DISTANCE 1	1				
14	90501-23215	SPRING, COMPRESSION	1				
15	6X4-44188-00	WASHER	2				
16	90386-08032	BUSH	1				
17	63D-42126-00	FRICTION, STEERING HANDLE GRIP	1				
18	6X4-48154-00	KNOB, THROTTLE	1				
19	95380-06600	NUT, HEXAGON	1				
20	91490-20010	PIN. COTTER	1				
21	6X4-44100-01	SHIFT LINK ASSY	1				
22	6X4-42115-00	.SHAFT, STEERING HANDLE	1				
23	6X4-44102-00	.SHIFT ASSIST ASSY.	1				
24	6X4-47731-01	.GEAR, DRIVE	1				
25	6X4-44132-00	.BUSHING	1				
26	6X4-14137-00	.CLIP	1				
27	6X4-48261-00	.ARM, THROTTLE	1				

6X4 TILLER HANDLE KIT (F25A)

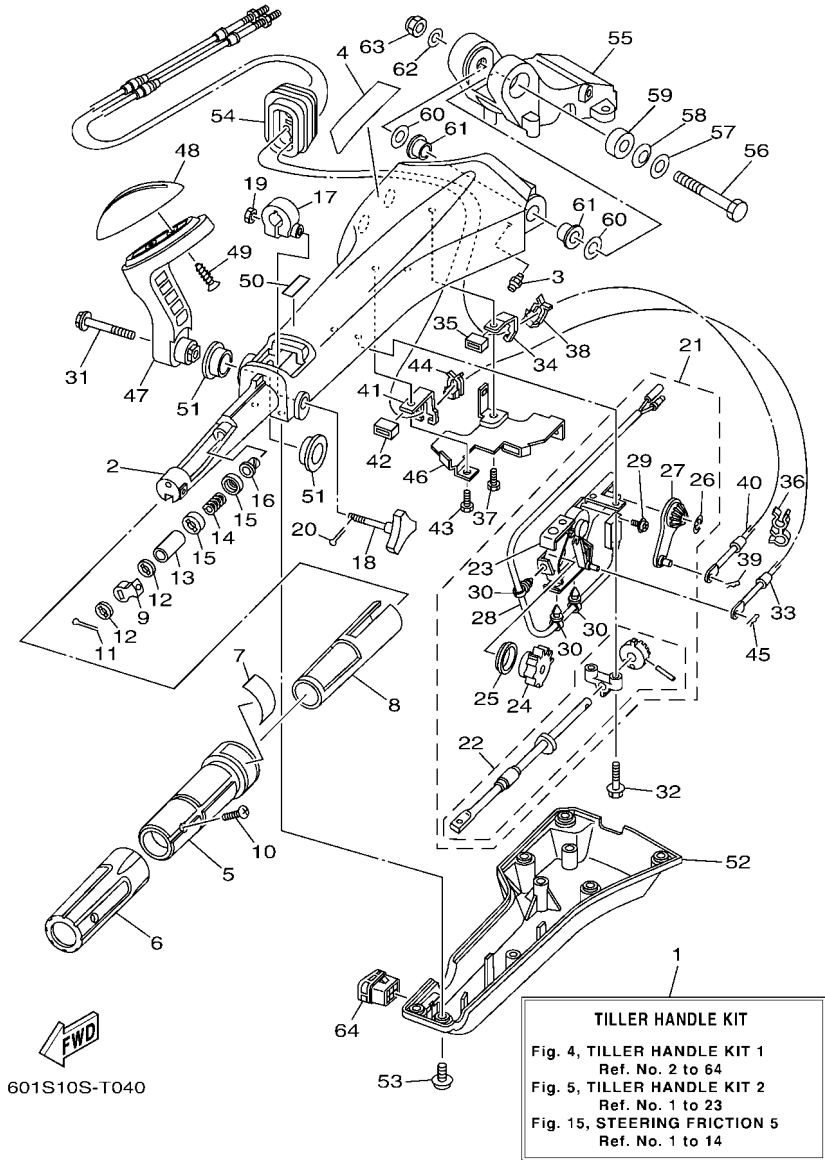

FIG. 4 TILLER HANDLE KIT 1

REF. NO.	PART NO.	DESCRIPTION	QTY	REMARKS
28	6X4-82540-00	.NEUTRAL SWITCH ASSY	1	
29	703-48129-00	.SCREW 3	2	
30	6X4-42821-00	.BAND, CLAMP	3	
31	97E95-08540	BOLT, HEXAGON W/W DEEP RECESS	1	
32	97E95-06530	BOLT, HEXAGON W/W DEEP RECESS	2	
33	6H1-48321-21	CABLE	1	
34	6X4-48538-00	CLAMP, CABLE 1	1	
35	6X4-26367-01	PROTECTOR	1	
36	90464-09M42	CLAMP	1	
37	97D95-06014	BOLT, HEXAGON DEEP RECESS	1	
38	63D-48538-00	CLAMP, CABLE 1	1	
39	90468-10005	CLIP	1	
40	6H3-48321-02	CABLE	1	
41	6X4-48538-10	CLAMP, CABLE 1	1	
42	6X4-26367-01	PROTECTOR	1	
43	97D95-06014	BOLT, HEXAGON DEEP RECESS	1	
44	63D-48538-00	CLAMP, CABLE 1	1	
45	90468-10005	CLIP	1	
46	6X4-42159-00	STAY	1	
47	6X4-44159-A0-8D	HANDLE, GEAR SHIFT	1	
48	6X4-44173-00	LEVER, SHIFT CONTROL	1	
49	97780-60920	SCREW, TAPPING	2	
50	6G8-44191-00	INDICATOR, SHIFT	1	
51	90386-26MA3	BUSH	2	
52	6X4-42131-01	COVER, HANDLE STEERING	1	
53	97985-06216	SCREW, WITH WASHER	6	
54	6X4-42725-01	GROMMET	1	

6X4 TILLER HANDLE KIT (F25A)

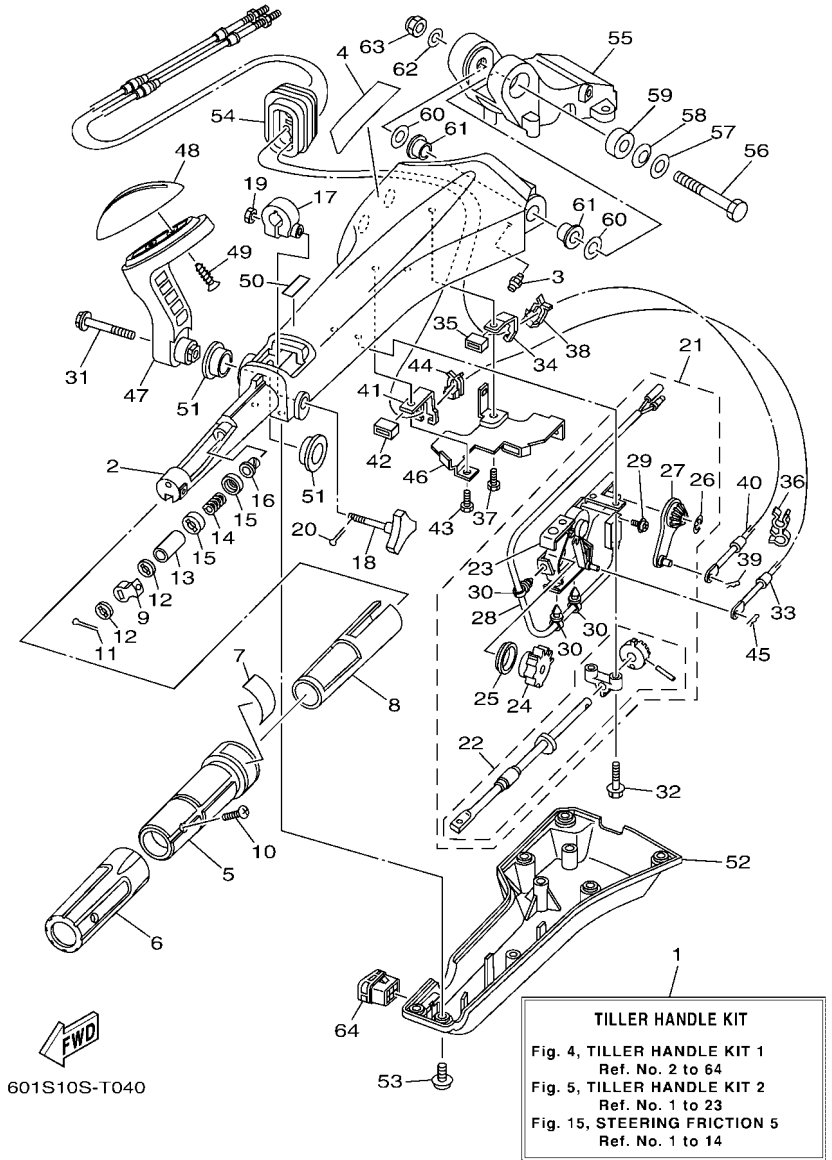
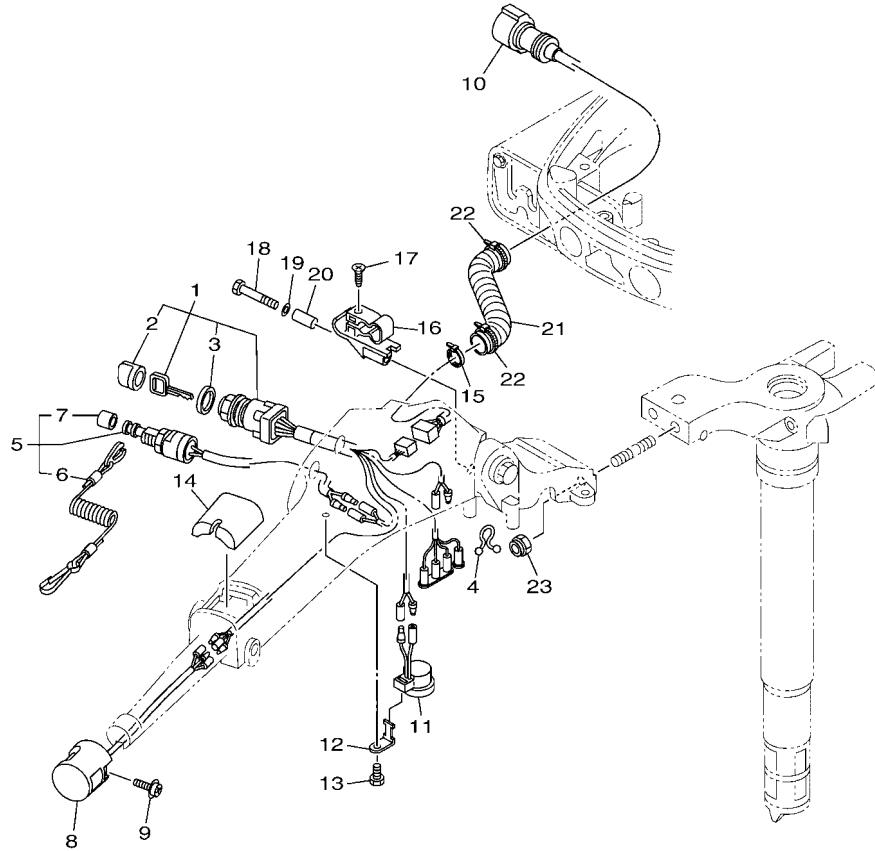

FIG. 4 TILLER HANDLE KIT 1

REF. NO.	PART NO.	DESCRIPTION	601S				REMARKS
55	65W-42121-11-4D	BRACKET	1				
56	90101-12014	BOLT	1				
57	92990-12200	WASHER, PLAIN	1				
58	90206-12M22	WASHER, WAVE	1				
59	90387-12M02	COLLAR	1				
60	90201-12035	WASHER, PLATE	2				
61	90386-12003	BUSH	2				
62	92990-12600	WASHER, PLATE	1				
63	90185-12M12	NUT, SELF-LOCKING	1				
64	6X4-42728-10	CAP	1				

6X4 TILLER HANDLE KIT (F25A)



 601S10S-T050

FIG. 5 TILLER HANDLE KIT 2

REF. NO.	PART NO.	DESCRIPTION	601S				REMARKS
1	6X4-82510-02	MAIN SWITCH ASSY	1				
2	676-82577-01	.CAP, KEY	1				
3	703-82532-00	.CAP	1				
4	90464-08M07	CLAMP	1				
5	69W-82575-00	ENGINE STOP SWITCH ASSY	1				
6	682-82556-00	.LANYARD, STOP SWITCH	1				
7	689-8257Y-00	.CAP	1				
8	6X4-82563-01	TRIM & TILT SWITCH ASSY	1				
9	97980-06216	SCREW, WITH WASHER	1				
10	6X4-82586-10	EXT., WIRE HARNESS (L:950MM)	1				
11	6X4-83383-00	BUZZER	1				
12	6X4-83386-00	STAY, BUZZER	1				
13	97D95-06014	BOLT, HEXAGON DEEP RECESS	1				
14	6X4-81942-01	COVER	1				
15	90465-13M36	CLAMP	1				
16	62Y-82361-00	CLAMP, CORD	1				
17	90161-06M03	SCREW, TAPPING	1				
18	97D95-06035	BOLT, HEXAGON DEEP RECESS	1				
19	92995-06600	WASHER	1				
20	90387-06M26	COLLAR	1				
21	90447-22006	TUBE	1				
22	90465-13M24	CLAMP	2				
23	90185-10027	NUT, SELF-LOCKING	2				

6X4 TILLER HANDLE FITTING KIT (F75B, VF90A, F90B, F115B, VF115A, F130A)

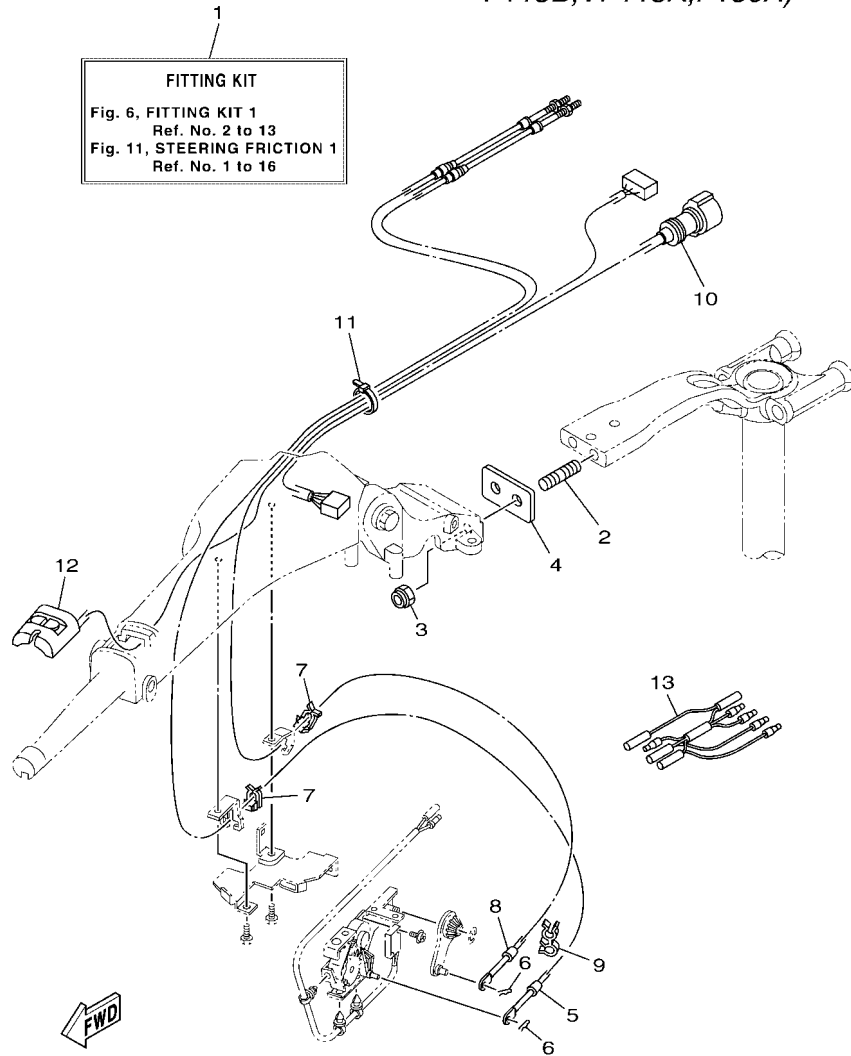

601S10S-T060

FIG. 6 FITTING KIT 1

REF. NO.	PART NO.	DESCRIPTION	601S				REMARKS
1	6X4-42102-H2	FITTING KIT	1				LM FOR USA,CAN
	6X4-42102-J2	FITTING KIT	1				LM FOR USA,CAN
	6X4-42102-C2	FITTING KIT	1				LM FOR EUR,OCE
2	90116-10063	BOLT, STUD	2				
3	90185-10027	NUT, SELF-LOCKING	2				
4	6EK-42121-00	BRACKET	1				
5	6EK-48321-00	CABLE	1				
6	90468-10005	CLIP	2				
7	63D-48538-00	CLAMP, CABLE 1	2				
8	6EK-26301-00	THROTTLE CABLE ASSY	1				FOR 6X4-42102-H2/C2
	6FP-26301-00	THROTTLE CABLE ASSY	1				FOR 6X4-42102-J2
9	90464-09M42	CLAMP	1				
10	6X4-82586-10	EXT., WIRE HARNESS (L:950MM)	1				
11	90465-13M24	CLAMP	1				
12	6X4-81860-00	SWITCH ASSY	1				
13	6X4-82521-00	WIRE, LEAD	1				FOR 6X4-42102-H2/J2

6X4 TILLER HANDLE FITTING KIT
(F50B,F50H,T50B,FT50J,F60B,F60F,T60B,FT60G,F70A)

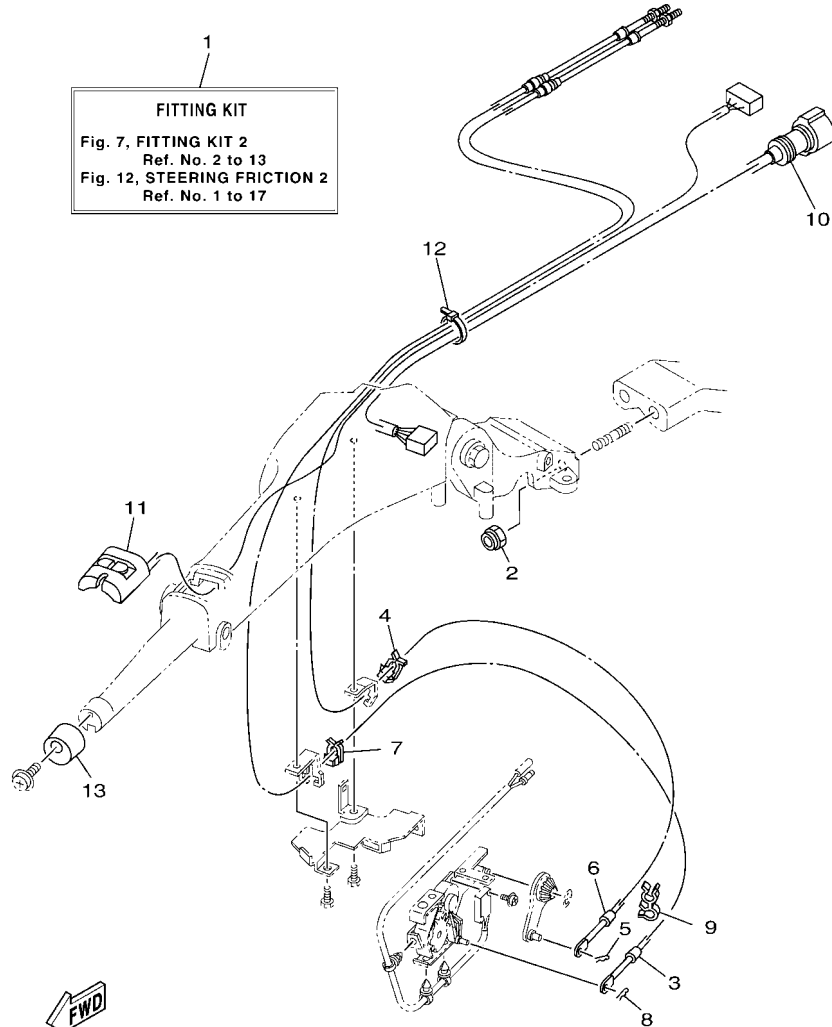

601S10S-T070

FIG. 7 FITTING KIT 2

REF. NO.	PART NO.	DESCRIPTION	601S	REMARKS
1	6X4-42102-23	FITTING KIT	1	LM FOR USA,CAN
	6X4-42102-92	FITTING KIT	1	LM FOR EUR,OCE
2	90185-10027	NUT, SELF-LOCKING	2	
3	67C-48321-11	CABLE	1	
4	63D-48538-00	CLAMP, CABLE 1	1	
5	90468-10005	CLIP	1	
6	69W-26301-00	THROTTLE CABLE ASSY	1	
7	63D-48538-00	CLAMP, CABLE 1	1	
8	90468-10005	CLIP	1	
9	90464-09M42	CLAMP	1	
10	6X4-82586-10	EXT., WIRE HARNESS (L:950MM)	1	
11	6X4-81860-00	SWITCH ASSY	1	
12	90465-13M36	CLAMP	1	
13	6X4-42728-00	CAP	1	FOR EUR,OCE

**6X4 TILLER HANDLE FITTING KIT
(F30A, F30B, F40A, F40F)**

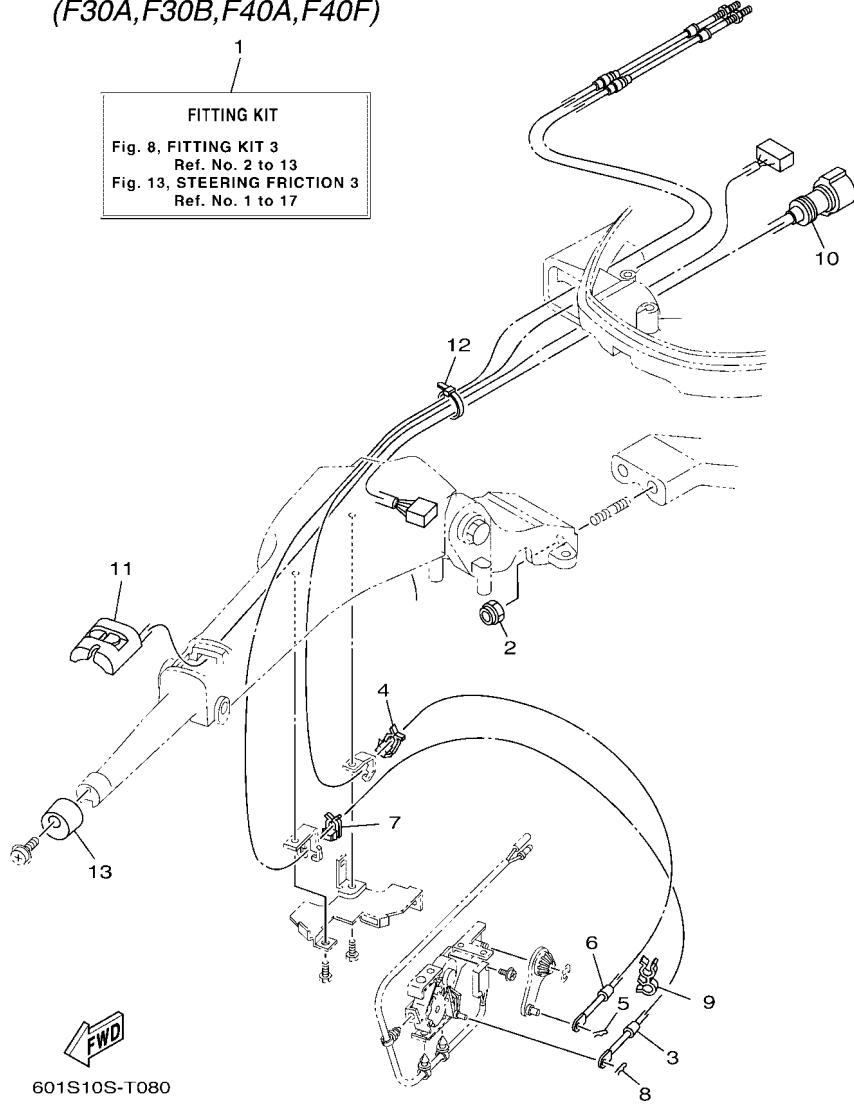
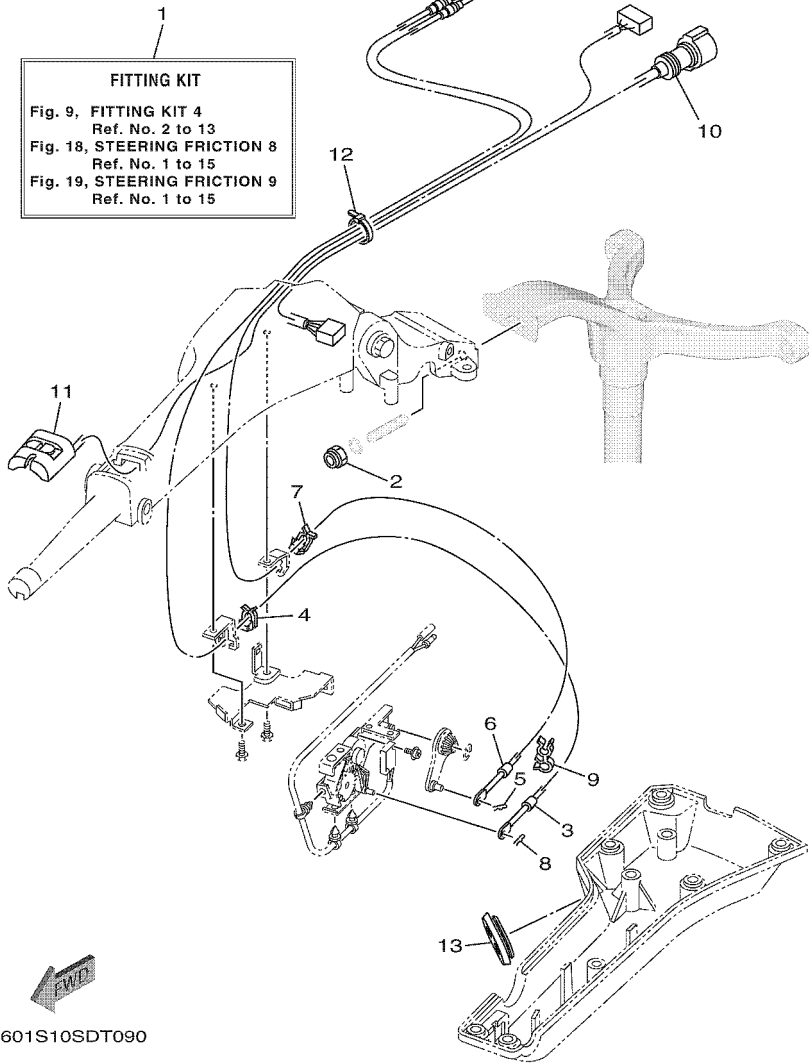

FIG. 8 FITTING KIT 3

REF. NO.	PART NO.	DESCRIPTION	601S	REMARKS
1	6X4-42102-71	FITTING KIT	1	LM FOR USA,CAN
	6X4-42102-82	FITTING KIT	1	LM FOR EUR,OCE
2	90185-10027	NUT, SELF-LOCKING	2	
3	67C-48321-11	CABLE	1	
4	63D-48538-00	CLAMP, CABLE 1	1	
5	90468-10005	CLIP	1	
6	69W-26301-00	THROTTLE CABLE ASSY	1	
7	63D-48538-00	CLAMP, CABLE 1	1	
8	90468-10005	CLIP	1	
9	90464-09M42	CLAMP	1	
10	6X4-82586-10	EXT., WIRE HARNESS (L:950MM)	1	
11	6X4-81860-00	SWITCH ASSY	1	
12	90465-13M36	CLAMP	1	
13	6X4-42728-00	CAP	1	FOR EUR,OCE

**6X4 TILLER HANDLE FITTING KIT
(F20B,F20G,F25C,T25C,F25G)**



601S10SDT090

FIG. 9 FITTING KIT 4

REF. NO.	PART NO.	DESCRIPTION	601S				REMARKS
1	6X4-42102-E1	FITTING KIT	1				LM FOR USA,CAN
	6X4-42102-K1	FITTING KIT	1				LM FOR USA,CAN
	6X4-42102-F1	FITTING KIT	1				LM FOR EUR,OCE
	6X4-42102-L1	FITTING KIT	1				LM FOR EUR,OCE
2	90185-10027	NUT, SELF-LOCKING	2				
3	63D-48321-11	CABLE	1				
4	63D-48538-00	CLAMP, CABLE 1	1				
5	90468-10005	CLIP	1				
6	6FM-26301-10	THROTTLE CABLE ASSY	1				
7	63D-48538-00	CLAMP, CABLE 1	1				
8	90468-10005	CLIP	1				
9	90464-09M42	CLAMP	1				
10	6X4-82586-10	EXT., WIRE HARNESS (L:950MM)	1				
11	6X4-81860-00	SWITCH ASSY	1				
12	90465-13M39	CLAMP	1				
13	6H3-42727-00	GROMMET	1				FOR EUR,OCE

6X4 TILLER HANDLE FITTING KIT (F75B,F75F,F80D,F90B,
VF90A,F100F,F100G)

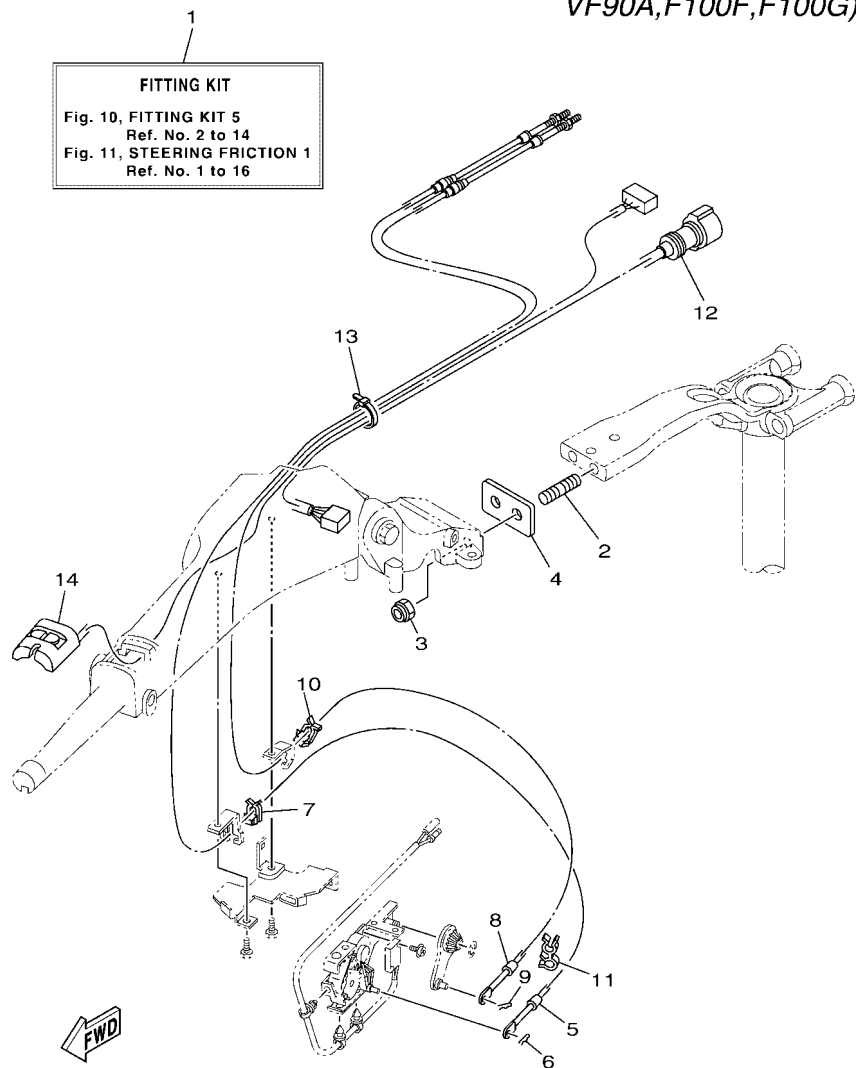

601S10S-U100

FIG. 10 FITTING KIT 5

REF. NO.	PART NO.	DESCRIPTION	601S				REMARKS
1	6X4-42102-G2	FITTING KIT	1				LM FOR EUR,OCE
2	90116-10063	BOLT, STUD	2				
3	90185-10027	NUT, SELF-LOCKING	2				
4	6EK-42121-00	BRACKET	1				
5	6EK-48321-00	CABLE	1				
6	90468-10005	CLIP	1				
7	63D-48538-00	CLAMP, CABLE 1	1				
8	6FP-26301-00	THROTTLE CABLE ASSY	1				
9	90468-10005	CLIP	1				
10	63D-48538-00	CLAMP, CABLE 1	1				
11	90464-09M42	CLAMP	1				
12	6X4-82586-10	EXT., WIRE HARNESS (L:950MM)	1				
13	90465-13M24	CLAMP	1				
14	6X4-81860-00	SWITCH ASSY	1				

STEERING FRICTION

Part No.	Applicable model
67G-42508-12	F75B, F75F, F80D, VF90A, F90C(F90B), F100G, F115B (F115B), VF115A, F130A (F130A)

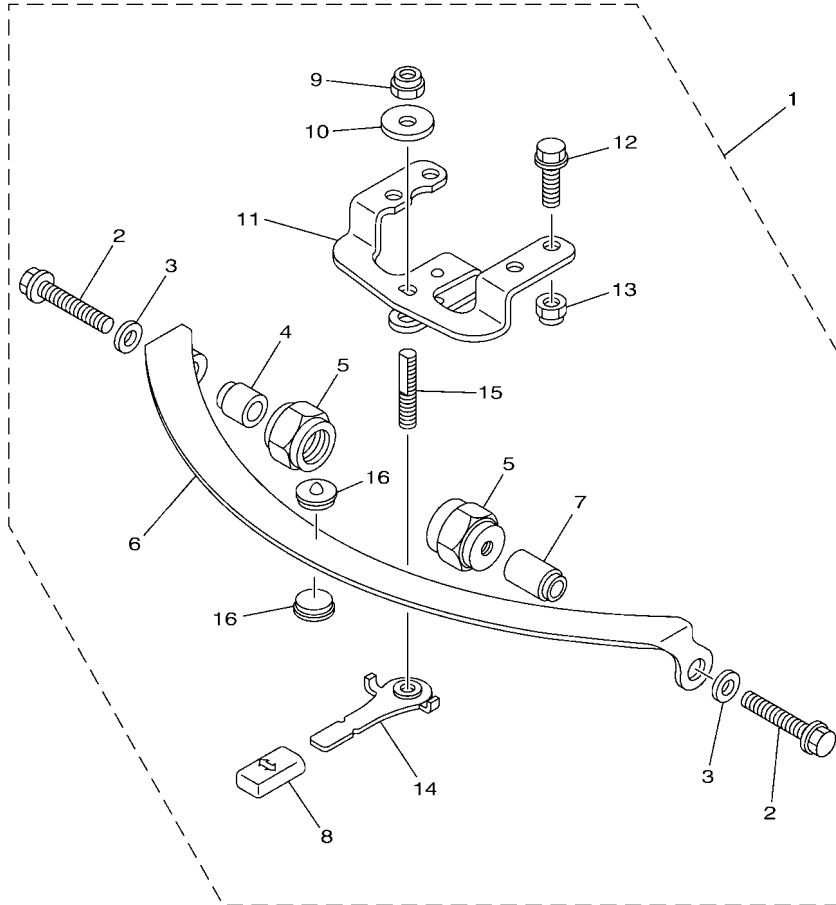

601S10S-U110

FIG. 11 STEERING FRICTION 1

REF. NO.	PART NO.	DESCRIPTION	601S				REMARKS
1	67G-42508-12	STEERING FRICTION ASSY	1				
2	90119-08198	.BOLT, WITH WASHER	2				
3	90201-08M01	.WASHER, PLATE	2				
4	67G-42541-00	.PIPE 1	1				
5	67G-42546-00	.NUT	2				
6	63D-42527-00	.PLATE, FRICTION	1				
7	67G-42541-10	.PIPE 1	1				
8	682-43318-01	.COVER	1				
9	90185-10M14	.NUT, SELF-LOCKING	1				
10	90201-10M76	.WASHER, PLATE	1				
11	6X4-42526-00	.PLATE, FRICTION	1				
12	97E95-08525	.BOLT, HEXAGON W/W DEEP RECESS	2				
13	90185-08057	.NUT, SELF-LOCKING	2				
14	67G-42561-00	.KNOB, STEERING LOCK	1				
15	67G-42562-00	.SHAFT, STEERING LOCK	1				
16	63D-42528-00	.PLATE, FRICTION	2				

STEERING FRICTION

Part No.	Applicable model
6C5-42508-01	F40H, F40G, F50H (F50B), FT50J (T50B), F60F (F60B), FT80G (T80B), F70A(F70A)

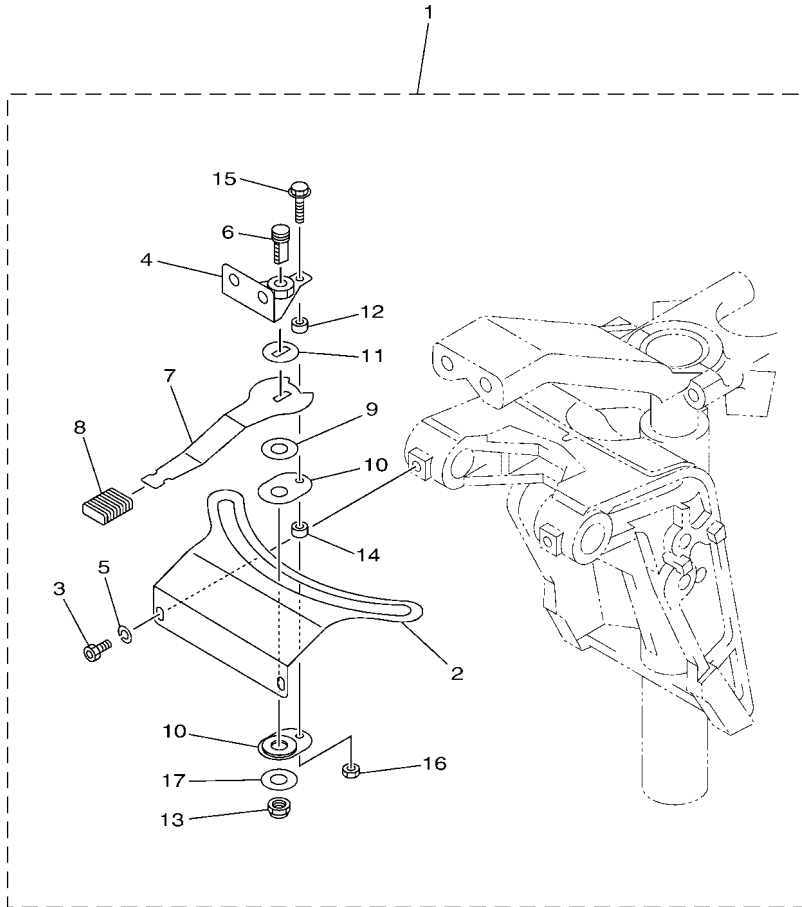

601S10S-T120

FIG. 12 STEERING FRICTION 2

REF. NO.	PART NO.	DESCRIPTION	601S				REMARKS
1	6C5-42508-01	STEERING FRICTION ASSY	1				
2	6C5-42527-00	.PLATE, FRICTION	1				
3	90109-06M88	.BOLT	2				
4	67C-42525-00	.PLATE, FRICTION	1				
5	92990-06100	.WASHER, SPRING	2				
6	67C-42562-A0	.SHAFT, STEERING LOCK	1				
7	67C-42561-00	.KNOB, STEERING LOCK	1				
8	689-43633-00	.COVER, TILT LEVER	1				
9	90202-10M56	.WASHER, PLATE	1				
10	65W-42528-00	.PLATE, FRICTION	2				
11	90209-10M26	.WASHER	1				
12	90387-05053	.COLLAR	1				
13	90185-10M14	.NUT, SELF-LOCKING	1				
14	90387-05054	.COLLAR	1				
15	97595-05520	.BOLT, WITH WASHER	1				
16	95380-05600	.NUT	1				
17	90201-106M5	.WASHER, PLATE	1				

STEERING FRICTION

Part No.	Applicable model
67C-42508-04	F30B (F30A), F40F (F40A)

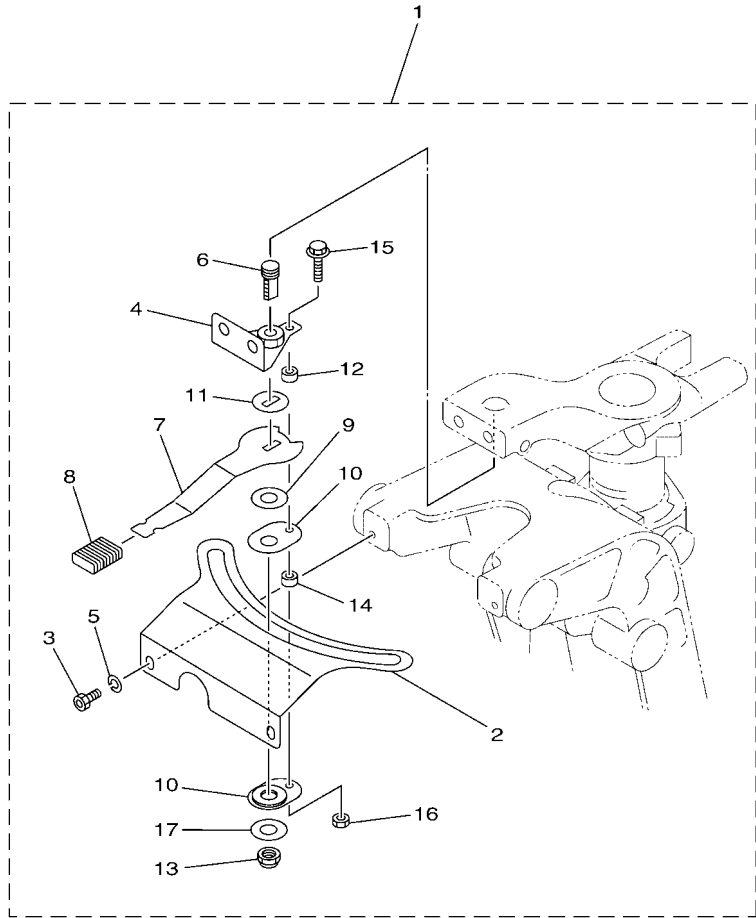

601S10S-T130

FIG. 13 STEERING FRICTION 3

REF. NO.	PART NO.	DESCRIPTION	601S				REMARKS
1	67C-42508-04	STEERING FRICTION ASSY	1				
2	67C-42527-03	.PLATE, FRICTION	1				
3	90109-06M88	.BOLT	2				
4	67C-42525-00	.PLATE, FRICTION	1				
5	92990-06100	.WASHER, SPRING	2				
6	67C-42562-A0	.SHAFT, STEERING LOCK	1				
7	67C-42561-00	.KNOB, STEERING LOCK	1				
8	689-43633-00	.COVER, TILT LEVER	1				
9	90202-10M56	.WASHER, PLATE	1				
10	65W-42528-00	.PLATE, FRICTION	2				
11	90209-10M26	.WASHER	1				
12	90387-05053	.COLLAR	1				
13	90185-10M14	.NUT, SELF-LOCKING	1				
14	90387-05054	.COLLAR	1				
15	97595-05520	.BOLT, WITH WASHER	1				
16	95380-05600	.NUT	1				
17	90201-106M5	.WASHER, PLATE	1				

STEERING FRICTION

Part No.	Applicable model
6AH-42508-02	F8F(F8B), FT8G, F9.9J(F9.9B), F9.9H, FT9.9L(T9.9B), F15C (F15A), F20B (F20A), F20C
6AH-42508-12	FT9.9L(T9.9B), F15C (F15A), F20B (F20A)

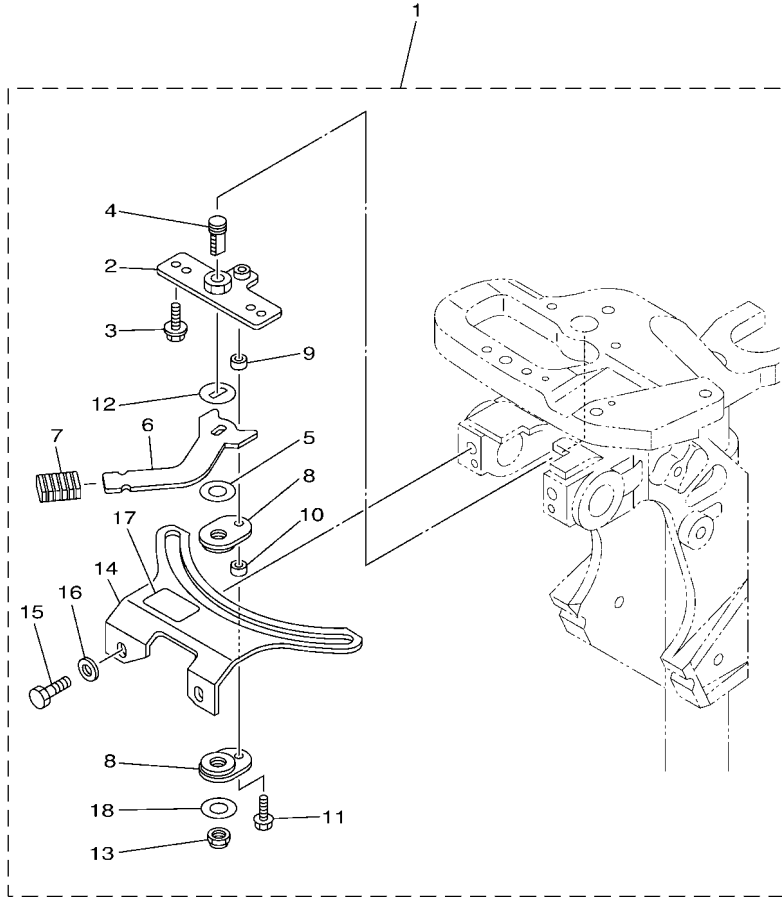

 601S10S-U140

FIG. 14 STEERING FRICTION 4

REF. NO.	PART NO.	DESCRIPTION	601S				REMARKS
1	6AH-42508-02	STEERING FRICTION ASSY	1				UR
	6AH-42508-12	STEERING FRICTION ASSY	1				UR
2	68T-42525-01	.PLATE, FRICTION	1				
3	90119-05018	.BOLT, WITH WASHER	2				
4	67C-42562-A0	.SHAFT, STEERING LOCK	1				
5	90202-10M56	.WASHER, PLATE	1				
6	68T-42561-00	.KNOB, STEERING LOCK	1				
7	689-43633-00	.COVER, TILT LEVER	1				
8	65W-42528-00	.PLATE, FRICTION	2				
9	90387-05053	.COLLAR	1				
10	90387-05054	.COLLAR	1				
11	97595-05520	.BOLT, WITH WASHER	1				
12	90209-10M26	.WASHER	1				
13	90185-10M14	.NUT, SELF-LOCKING	1				
14	6AH-42527-00	.PLATE, FRICTION	1				
15	90101-08022	.BOLT	2				
16	90201-08065	.WASHER, PLATE	2				
17	68T-43155-00	.MARK 1	1				FOR 6AH-42508-02
18	90201-106M5	.WASHER, PLATE	1				

STEERING FRICTION

Part No.	Applicable model
65W-42508-00	F25D (F25A), (E)40X

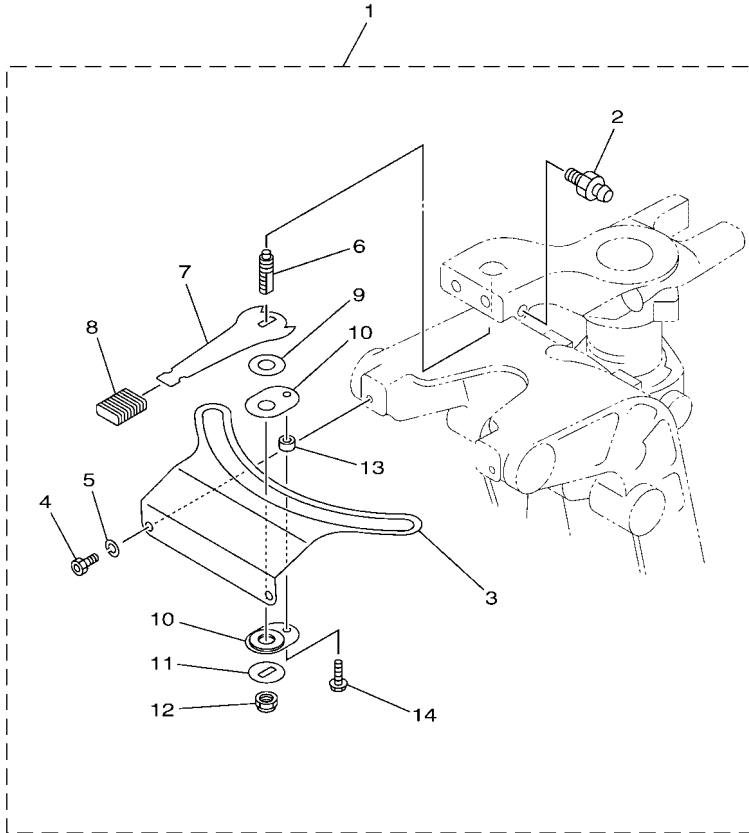

601S10S-T150

FIG. 15 STEERING FRICTION 5

REF. NO.	PART NO.	DESCRIPTION	601S				REMARKS
1	65W-42508-00	STEERING FRICTION ASSY	1				
2	93700-06M03	.NIPPLE, GREASE	1				
3	65W-42527-00	.PLATE, FRICTION	1				
4	90109-06M88	.BOLT	2				
5	92990-06100	.WASHER, SPRING	2				
6	65W-42562-00	.SHAFT, STEERING LOCK	1				
7	65W-42561-00	.KNOB, STEERING LOCK	1				
8	689-43633-00	.COVER, TILT LEVER	1				
9	90202-10M56	.WASHER, PLATE	1				
10	65W-42528-00	.PLATE, FRICTION	2				
11	90209-10M26	.WASHER	1				
12	90185-10M14	.NUT, SELF-LOCKING	1				
13	90387-05054	.COLLAR	1				
14	90109-05M89	.BOLT	1				

STEERING FRICTION

Part No.	Applicable model
63D-42508-01	FT50C, F50D, 40V, 50H

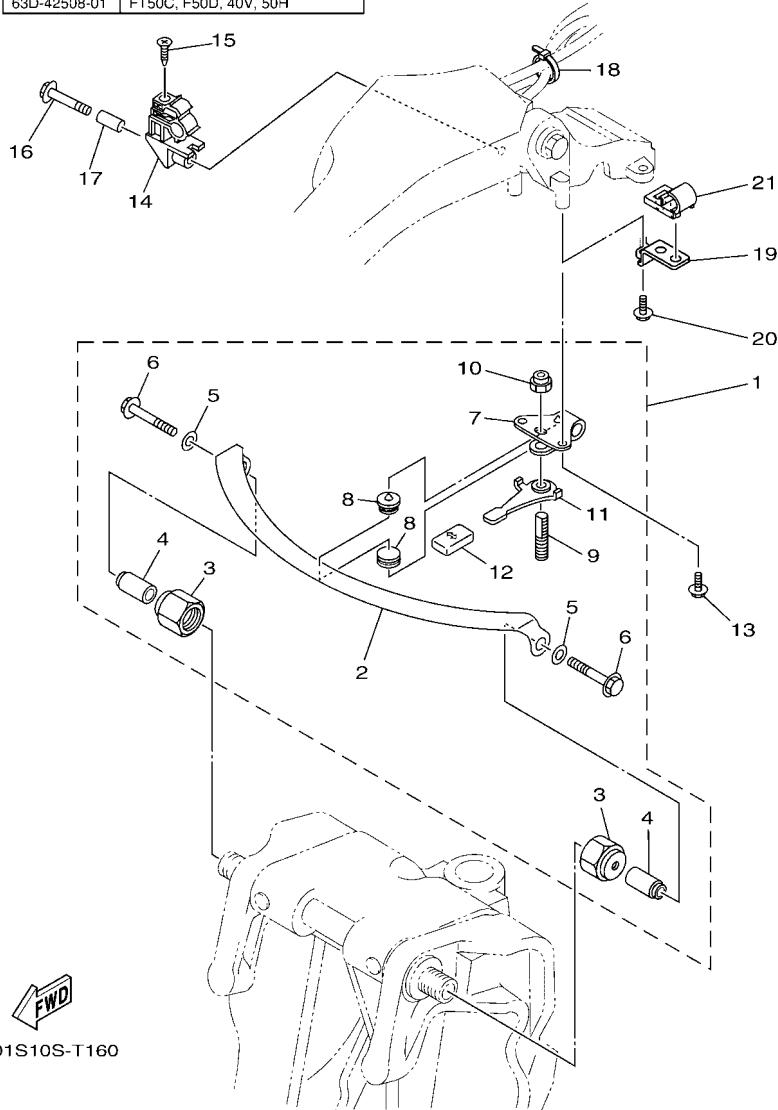

601S10S-T160

FIG. 16 STEERING FRICTION 6

REF. NO.	PART NO.	DESCRIPTION	601S				REMARKS
1	63D-42508-01	STEERING FRICTION ASSY	1				
2	63D-42527-00	.PLATE, FRICTION	1				
3	63D-42546-00	.NUT	2				
4	63D-42541-00	.PIPE 1	2				
5	90201-08M01	.WASHER, PLATE	2				
6	97E95-08550	.BOLT, HEXAGON W/W DEEP RECESS	2				
7	63D-42526-00	.PLATE, FRICTION	1				
8	63D-42528-00	.PLATE, FRICTION	2				
9	63D-42562-00	.SHAFT, STEERING LOCK	1				
10	90185-10M01	.NUT, SELF-LOCKING	1				
11	63D-42561-00	.KNOB, STEERING LOCK	1				
12	682-43318-01	.COVER	1				
13	97E95-06516	BOLT, HEXAGON W/W DEEP RECESS	2				
14	63D-82361-00	CLAMP, CORD	1				
15	90161-06M00	SCREW, TAPPING	1				
16	97E95-06535	BOLT, HEXAGON W/W DEEP RECESS	1				
17	90387-06M26	COLLAR	1				
18	90465-13M36	CLAMP	1				
19	63D-24364-10	STAY	1				
20	97E95-06516	BOLT, HEXAGON W/W DEEP RECESS	1				
21	63D-24367-00	CLAMP, FUEL PIPE 2	1				

STEERING FRICTION

Part No.	Applicable model
6FM-42508-10	F25G(F25C, T25C)

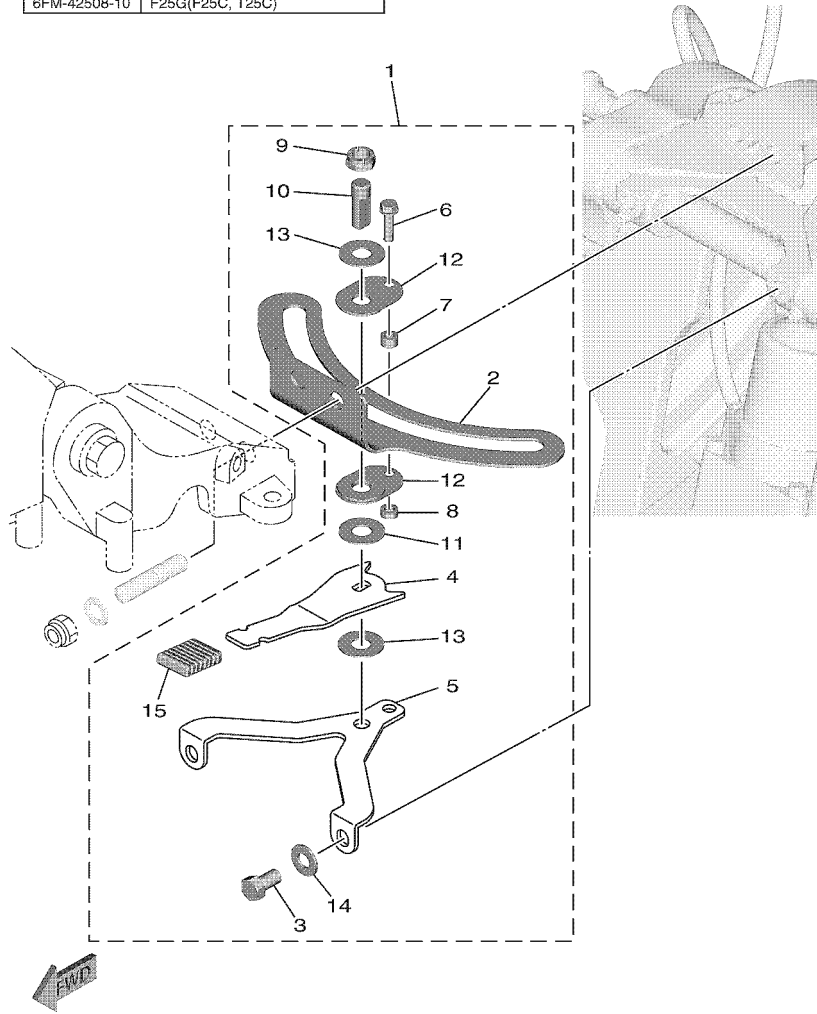
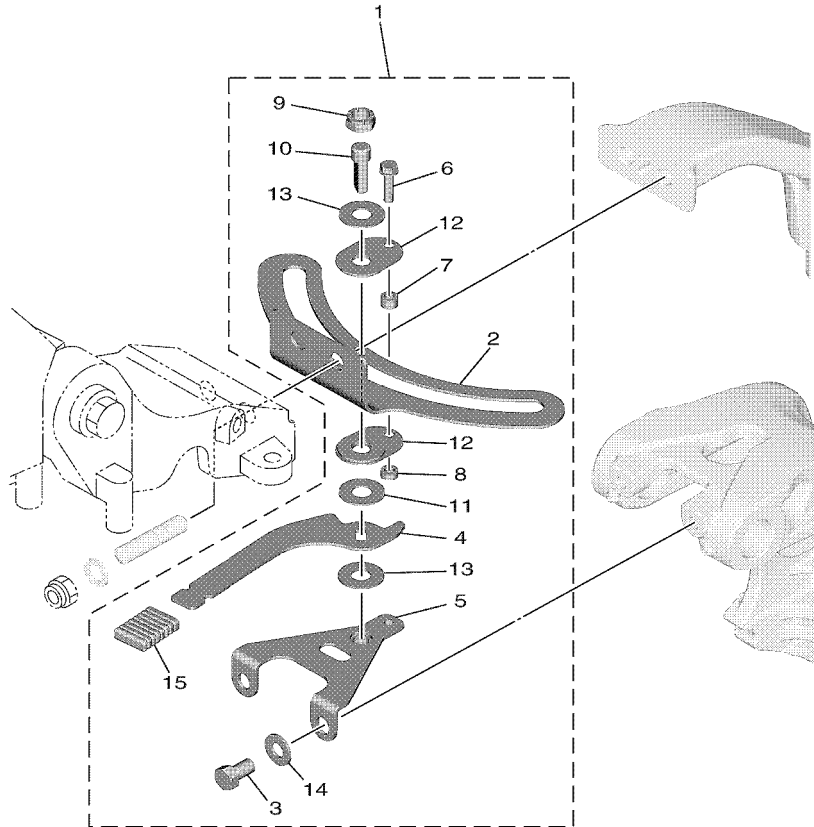

FIG. 18 STEERING FRICTION 8

REF. NO.	PART NO.	DESCRIPTION	601S				REMARKS
1	6FM-42508-10	STEERING FRICTION ASSY	1				
2	6FM-42527-00	.PLATE, FRICTION	1				
3	90109-08M91	.BOLT	2				
4	6FM-42561-10	.KNOB, STEERING LOCK	1				
5	6FM-42525-10	.PLATE, FRICTION	1				
6	97595-05520	.BOLT, WITH WASHER	1				
7	90387-05054	.COLLAR	1				
8	90387-05053	.COLLAR	1				
9	90185-10M14	.NUT, SELF-LOCKING	1				
10	67C-42562-A0	.SHAFT, STEERING LOCK	1				
11	90202-10M56	.WASHER, PLATE	1				
12	65W-42528-00	.PLATE, FRICTION	2				
13	90201-106M5	.WASHER, PLATE	2				
14	92995-08200	.WASHER	2				
15	689-43633-00	.COVER, TILT LEVER	1				

STEERING FRICTION

Part No.	Applicable model
6FM-42508-00	F20G(F20B), F25G(F25C)



601S10SDT190

FIG. 19 STEERING FRICTION 9

REF. NO.	PART NO.	DESCRIPTION	601S				REMARKS
1	6FM-42508-00	STEERING FRICTION ASSY	1				
2	6FM-42527-00	.PLATE, FRICTION	1				
3	90109-08M91	.BOLT	2				
4	6FM-42561-00	.KNOB, STEERING LOCK	1				
5	6FM-42525-00	.PLATE, FRICTION	1				
6	97595-05520	.BOLT, WITH WASHER	1				
7	90387-05054	.COLLAR	1				
8	90387-05053	.COLLAR	1				
9	90185-10M14	.NUT, SELF-LOCKING	1				
10	67C-42562-A0	.SHAFT, STEERING LOCK	1				
11	90202-10M56	.WASHER, PLATE	1				
12	65W-42528-00	.PLATE, FRICTION	2				
13	90201-106M5	.WASHER, PLATE	2				
14	92995-08200	.WASHER	2				
15	689-43633-00	.COVER, TILT LEVER	1				

NUMERICAL INDEX

PART NO.	REF. NO.	PART NO.	REF. NO.	PART NO.	REF. NO.	PART NO.	REF. NO.	PART NO.	REF. NO.	PART NO.	REF. NO.
6X4-14137-00	1 - 26	6X4-42137-00	1 - 7	65W-42561-00	15 - 7	6X4-44177-00	4 - 12	6X4-82510-02	5 - 1	90116-10063	6 - 2
	4 - 26		4 - 7	67C-42561-00	12 - 7	6X4-44188-00	1 - 15	6X4-82510-42	3 - 1		10 - 2
63D-24364-10	16 - 19	6X4-42159-00	1 - 39		13 - 7		4 - 15	6X4-82521-00	6 - 13	90119-05018	14 - 3
63D-24367-00	16 - 21		4 - 46	67G-42561-00	11 - 14	6G8-44191-00	1 - 43	703-82532-00	2 - 3	90119-08198	11 - 2
69W-26301-00	7 - 6	6X4-42177-01	1 - 6	68T-42561-00	14 - 6		4 - 50		3 - 3	90152-05007	1 - 10
	8 - 6		4 - 6	6FM-42561-00	19 - 4	6X4-47731-01	1 - 24		5 - 3		4 - 10
6EK-26301-00	6 - 8	65W-42508-00	15 - 1	6FM-42561-10	18 - 4		4 - 24	6X4-82540-00	1 - 28	90161-06M00	16 - 15
6FP-26301-00	6 - 8	6FM-42508-00	19 - 1	63D-42562-00	16 - 9	703-48129-00	1 - 29		4 - 28	90161-06M03	5 - 17
	10 - 8	63D-42508-01	16 - 1	65W-42562-00	15 - 6		4 - 29	682-82556-00	2 - 6	90175-06003	17 - 5
6FM-26301-10	9 - 6	692-42508-01	17 - 1	67G-42562-00	11 - 15	6X4-48154-00	1 - 18		3 - 6	90185-08057	11 - 13
6X4-26367-01	1 - 34	6C5-42508-01	12 - 1	67C-42562-A0	12 - 6		4 - 18		5 - 6		17 - 8
	1 - 37	6AH-42508-02	14 - 1		13 - 6	6X4-48215-00	1 - 4	6X4-82563-01	2 - 8	90185-10027	5 - 23
	4 - 35	67C-42508-04	13 - 1		14 - 4		4 - 4		3 - 8		6 - 3
	4 - 42	6FM-42508-10	18 - 1		18 - 10	6X4-48261-00	1 - 27		5 - 8		7 - 2
6X4-41291-00	1 - 8	67G-42508-12	11 - 1		19 - 10		4 - 27	69W-82575-00	2 - 5		8 - 2
	4 - 8	6AH-42508-12	14 - 1	6X4-42725-01	1 - 47	6EK-48321-00	6 - 5		3 - 5		9 - 2
	7 - 1	692-42515-01	17 - 6		4 - 54		10 - 5		5 - 5		10 - 3
6X4-42102-23	8 - 1	663-42518-00	17 - 2	6H3-42727-00	9 - 13	6H3-48321-02	4 - 40	676-82577-01	2 - 2	90185-10M01	16 - 10
6X4-42102-71	8 - 1	67C-42525-00	12 - 4	6X4-42727-01	3 - 17	63D-48321-11	9 - 3		3 - 2	90185-10M14	11 - 9
6X4-42102-82	8 - 1		13 - 4	6X4-42728-00	7 - 13	67C-48321-11	7 - 3		5 - 2		12 - 13
6X4-42102-92	7 - 1		19 - 5		8 - 13		8 - 3	689-8257Y-00	2 - 7		13 - 13
6X4-42102-C2	6 - 1	6FM-42525-00	14 - 2	6X4-42728-10	1 - 57	6H1-48321-21	4 - 33		3 - 7		14 - 13
6X4-42102-E1	9 - 1	68T-42525-01	18 - 5		4 - 64	63D-48538-00	4 - 38		5 - 7		15 - 12
6X4-42102-F1	9 - 1	6FM-42525-10	16 - 7	6X4-42821-00	1 - 30		4 - 44	6X4-82586-10	5 - 10		18 - 9
6X4-42102-G2	10 - 1	63D-42526-00	11 - 11		4 - 30		6 - 7		6 - 10		19 - 9
6X4-42102-H2	6 - 1	6X4-42526-00	11 - 6	68T-43155-00	14 - 17		7 - 4		7 - 10	90185-12M12	1 - 56
6X4-42102-J2	6 - 1	63D-42527-00	16 - 2	682-43318-01	11 - 8		7 - 7		8 - 10		4 - 63
6X4-42102-K1	9 - 1		15 - 3	689-43633-00	12 - 8		8 - 4		9 - 10	90201-08065	14 - 16
6X4-42102-L1	9 - 1	65W-42527-00	14 - 14		13 - 8		8 - 7		10 - 12	90201-08M01	11 - 3
6X4-42103-OE	4 - 1	6AH-42527-00	12 - 2		14 - 7		9 - 4	6X4-83383-00	2 - 10		16 - 5
6X4-42103-5C	1 - 1	6C5-42527-00	18 - 2		15 - 8		9 - 7		3 - 10	90201-106M5	12 - 17
6X4-42103-6A	1 - 1	6FM-42527-00	19 - 2		18 - 15		10 - 7		5 - 11		13 - 17
6X4-42111-02-4D	4 - 2		13 - 2		19 - 15	6X4-48538-00	10 - 10	6X4-83386-00	2 - 11		14 - 18
6X4-42111-02-8D	1 - 2	67C-42527-03	11 - 16	6X4-44100-01	1 - 21		1 - 33		3 - 11		18 - 13
6X4-42115-00	1 - 22	63D-42528-00	16 - 8		4 - 21		4 - 34		5 - 12		19 - 13
	4 - 22		12 - 10	6X4-44102-00	1 - 23	6X4-48538-10	1 - 36	6H4-83589-00	3 - 18	90201-10M76	11 - 10
6X4-42119-01	1 - 5	65W-42528-00	13 - 10		4 - 23		4 - 41	6X4-83653-20	3 - 13	90201-12035	1 - 53
	4 - 5		14 - 8	6X4-44114-00	3 - 15	6X4-81860-00	6 - 12	6C5-84301-00	3 - 14		4 - 60
6EK-42121-00	6 - 4		15 - 10	6X4-44132-00	1 - 25		7 - 11	6X4-85415-00	3 - 19	90202-10M56	12 - 9
	10 - 4		18 - 12	6X4-44139-01	1 - 9		8 - 11	90101-08022	14 - 15		13 - 9
65W-42121-11-4D	4 - 55		19 - 12		4 - 25		9 - 11	90101-12014	1 - 49		14 - 5
63D-42121-22-8D	1 - 48	663-42528-00	17 - 3	6X4-44159-A0-8D	1 - 40	6X4-81942-01	10 - 14		4 - 56		15 - 9
63D-42126-00	1 - 17	63D-42541-00	16 - 4		4 - 9		2 - 13	90109-05M89	15 - 14		18 - 11
	4 - 17	67G-42541-00	11 - 4		4 - 47		3 - 20	90109-06M88	12 - 3		19 - 11
6X4-42128-00	1 - 13	67G-42541-10	11 - 7	6X4-44173-00	1 - 41		5 - 14		13 - 3	90206-12M22	1 - 51
	4 - 13	63D-42546-00	16 - 3		4 - 48	62Y-82361-00	5 - 16		15 - 4		4 - 58
6X4-42131-01	1 - 45	67G-42546-00	11 - 5	6X4-44177-00	1 - 12	63D-82361-00	16 - 14	90109-08M91	18 - 3	90209-10M26	12 - 11
	4 - 52	63D-42561-00	16 - 11			6X4-82510-02	2 - 1		19 - 3		13 - 11
6X4-42131-11	1 - 45										

NUMERICAL INDEX

PART NO.	REF. NO.	PART NO.	REF. NO.	PART NO.	REF. NO.	PART NO.	REF. NO.	PART NO.	REF. NO.	PART NO.	REF. NO.
90209-10M26	14 - 12	90468-10005	9 - 5	97D95-06014	5 - 13						
	15 - 11		9 - 8	97D95-06035	5 - 18						
90386-08032	1 - 16		10 - 6	97E95-06516	16 - 13						
	4 - 16		10 - 9		16 - 20						
90386-12003	1 - 54	90501-23215	1 - 14	97E95-06530	1 - 32						
	4 - 61		4 - 14		4 - 32						
90386-26MA3	1 - 44	91490-20010	1 - 11	97E95-06535	16 - 16						
	4 - 51		1 - 20	97E95-08525	11 - 12						
90387-05053	12 - 12		4 - 11	97E95-08540	1 - 31						
	13 - 12		4 - 20		4 - 31						
	14 - 9	92990-06100	12 - 5	97E95-08550	16 - 6						
	18 - 8		13 - 5								
	19 - 8		15 - 5								
90387-05054	12 - 14	92990-08600	17 - 7								
	13 - 14	92990-12200	1 - 50								
	14 - 10		4 - 57								
	15 - 13	92990-12600	1 - 55								
	18 - 7		4 - 62								
	19 - 7	92995-06600	5 - 19								
90387-06M26	5 - 20	92995-08200	18 - 14								
	16 - 17		19 - 14								
90387-12M02	1 - 52	93700-06002	1 - 3								
	4 - 59		4 - 3								
90447-22006	5 - 21	93700-06M03	15 - 2								
90464-08M07	2 - 4	95380-05600	12 - 16								
	3 - 4		13 - 16								
	5 - 4	95380-06600	1 - 19								
90464-09M42	4 - 36		4 - 19								
	6 - 9	97080-06035	17 - 4								
	7 - 9	97595-05520	12 - 15								
	8 - 9		13 - 15								
	9 - 9		14 - 11								
	10 - 11		18 - 6								
90465-13M24	5 - 22		19 - 6								
	6 - 11	97780-60620	3 - 16								
	10 - 13	97780-60920	1 - 42								
90465-13M36	5 - 15		4 - 49								
	7 - 12	97980-06216	2 - 9								
	8 - 12		3 - 9								
	16 - 18		5 - 9								
90465-13M39	9 - 12	97985-06216	1 - 46								
90468-10005	4 - 39		4 - 53								
	4 - 45	97D95-06014	1 - 35								
	6 - 6		1 - 38								
	7 - 5		2 - 12								
	7 - 8		3 - 12								
	8 - 5		4 - 37								
	8 - 8		4 - 43								