



# PARTS CATALOGUE

# RIGGING-STEERING

---



1S601-10SEA

( )

RIGGING-STEERING  
PARTS CATALOGUE

©2018 by Yamaha Motor Co., Ltd.  
1st edition, October 2018

All rights reserved.

Any reprinting or unauthorized use  
without the written permission of

Yamaha Motor Co., Ltd.

is expressly prohibited.

Printed in Japan.

# FOREWORD

This Parts Catalogue is related to the parts for the model(s) on the cover page. When you are ordering replacement parts, please refer to this Parts Catalogue and quote both part numbers and part names correctly.

1. Modifications or additions which have been made after the issue of the Parts Catalogue will be announced in the Parts News.  
It is advisable that you make the necessary corrections to the Parts Catalogue according to the Parts News.

2. Abbreviations

The following abbreviations are used in this Parts Catalogue.

“UR” Use specified parts number.

“UN” Use as many as needed.

“AP” Alternate Parts

“LM” Locally Made (Parts need to be ordered locally)

“F#” Frame No. (Applicable machine No.)

“O/S” Over Size

3. The number of components for assembly

- Parts, which are to be supplied in an assembly, are listed with a dot (.) in front of the part name as shown below.
- The numeral appearing to the right of each component part indicates the quantity of parts for each assembly unit.

PART NO.	DESCRIPTION	Q'TY	REMARKS
2F5-83310-60	FRONT FLASHER LIGHT ASSY	2	
115-83311-60	.BULB (6V-18W)	1	

4. Applicable colours of graphics are represented in the “REMARKS” as shown below.

PART NO.	DESCRIPTION	Q'TY	REMARKS
2N4-24110-00-X5	FUEL TANK COMP.	2	MXR
3J1-24240-10	.GRAPHIC, FUEL TANK	1	FOR MXR

5. Note that the illustrations for reference in finding parts numbers are not to be used for assembling. When assembling, please use the applicable service manual.

6. The asterisk (\*) before a reference number indicates modified items after the first edition.

# CONTENTS

BASE HANDLE - ALL.....	1
BASE HANDLE ELECTRICAL 1.....	4
BASE HANDLE ELECTRICAL 2.....	5
TILLER HANDLE KIT 1.....	6
TILLER HANDLE KIT 2.....	9
FITTING KIT 1.....	10
FITTING KIT 2.....	11
FITTING KIT 3.....	12
FITTING KIT 4.....	13
FITTING KIT 5.....	14
FITTING KIT 6.....	15
STEERING FRICTION 1.....	16
STEERING FRICTION 2.....	17
STEERING FRICTION 3.....	18
STEERING FRICTION 4.....	19
STEERING FRICTION 5.....	20
STEERING FRICTION 6.....	21
STEERING FRICTION 7.....	22
STEERING FRICTION 8.....	23

## INDEX

NUMERICAL INDEX.....	24
----------------------	----

# Application Model

PART NO. / PART NAME																	
FIG.NO.																	
FOR USA, CANADA										FOR EUROPE, OCEANIA							
MODEL CODE	MODEL NAME	SERIAL NO.	6X4-42103-58 TILLER HANDLE KIT	6X4-42103-0C TILLER HANDLE KIT	6X4-42102-H0 FITTING KIT	6X4-42102-J0 FITTING KIT	6X4-42102-11 FITTING KIT	6X4-42102-23 FITTING KIT	6X4-42102-71 FITTING KIT	6X4-42102-E0 FITTING KIT	6X4-42103-66 TILLER HANDLE KIT	6X4-42102-C0 FITTING KIT	6X4-42102-A1 FITTING KIT	6X4-42102-92 FITTING KIT	6X4-42102-82 FITTING KIT	6X4-42102-F0 FITTING KIT	6X4-42102-G0 FITTING KIT
			FIG.1, 2	FIG.4, 5, 16	FIG.6, 12	FIG.6, 12	FIG.7, 12	FIG.8, 13	FIG.9, 14	FIG.10, 19	FIG.1, 3	FIG.6, 12	FIG.7, 12	FIG.8, 13	FIG.9, 14	FIG.10, 19	FIG.11, 12
6BPB	F25A-2018 F25B-2018	6BPK-1039818-		*													
6EK5	F115B F115B-2018	6EK-1053511-	*		*						*	*					
6FN4	VF115A-2018	6FN-1009857-	*		*						*	*					
6EM4	F130A F130A-2018	6EM-1004869-	*		*						*	*					
6C1F	F50H F50B-2018	6C1-1076795-	*					*			*			*			
6C5F	F60F F60B-2018	6C5-1082606-	*					*			*			*			
6C2F	FT50J T50B-2018	6C2-1026078-	*					*			*			*			
6C6F	FT60G T60B-2018	6C6-1031992-	*					*			*			*			
6CJ9	F70A F70A-2018	6CJ-1074711-	*					*			*			*			
6BTB	F30B F30A-2018	6BT-1016971-	*						*		*				*		
6BGB	F40F F40A-2018	6BG-1067572-	*						*		*				*		
6D7F	F80B	6D7-1019696-									*		*				
6D9F	F100D	6D9-1029105-									*		*				
6GX2	F20F	6GXK-1000071-									*					*	
6FM2	F25G F25C-2018	6FMK-1012591-	*							*	*					*	
6HW2	F75B-2018	6HW-1000372-	*			*					*						*
6HV2	F80D	6HV-1000556-									*						*
6FP2	F90B-2018	6FP-1009003-	*			*					*						*
6HK1	VF90A-2018	6HK-1000001-	*				*				*						*
6HJ2	F100F	6HJ-1001936-									*						*

6X4 TILLER HANDLE KIT (F20F-F130A)

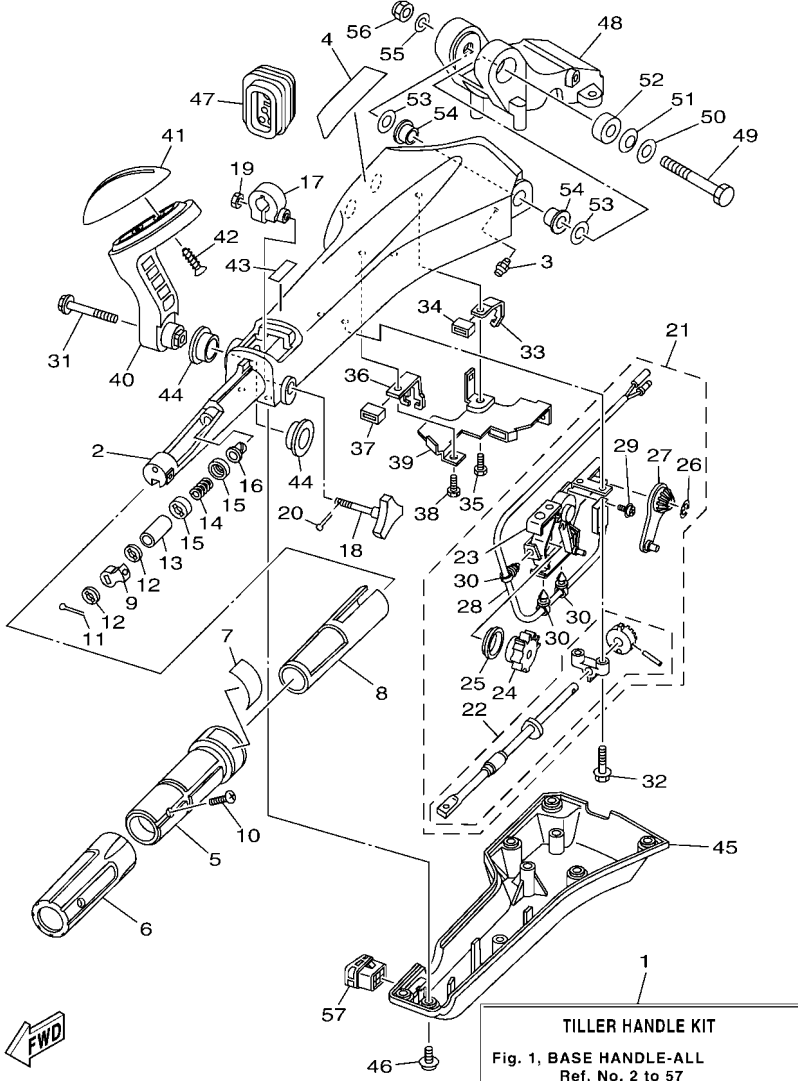

601S10S-R010

FIG. 1 BASE HANDLE - ALL

REF. NO.	PART NO.	DESCRIPTION	601S				REMARKS
1	6X4-42103-58	TILLER HANDLE KIT	1				LM FOR USA,CAN
	6X4-42103-66	TILLER HANDLE KIT	1				LM FOR EUR,OCE
2	6X4-42111-02-8D	HANDLE, STEERING	1				
3	93700-06M03	NIPPLE, GREASE	1				
4	6X4-48215-00	GRAPHIC	1				
5	6X4-42119-01	GRIP, STEERING HANDLE	1				
6	6X4-42177-00	RUBBER, HANDLE	1				
7	6X4-42137-00	INDICATOR, THROTTLE	1				
8	6X4-41291-00	BUSHING	1				
9	6X4-44139-01	COLLAR	1				
10	90152-05007	SCREW, COUNTERSUNK	1				
11	91490-20010	PIN. COTTER	1				
12	6X4-44177-00	WASHER	2				
13	6X4-42128-00	COLLAR, DISTANCE 1	1				
14	90501-23215	SPRING, COMPRESSION	1				
15	6X4-44188-00	WASHER	2				
16	90386-08032	BUSH	1				
17	63D-42126-00	FRICTION, STEERING HANDLE GRIP	1				
18	6X4-48154-00	KNOB, THROTTLE	1				
19	95380-06600	NUT, HEXAGON	1				
20	91490-20010	PIN. COTTER	1				
21	6X4-44100-01	SHIFT LINK ASSY	1				
22	6X4-42115-00	.SHAFT, STEERING HANDLE	1				
23	6X4-44102-00	.SHIFT ASSIST ASSY.	1				
24	6X4-47731-01	.GEAR, DRIVE	1				
25	6X4-44132-00	.BUSHING	1				
26	6X4-14137-00	.CLIP	1				

6X4 TILLER HANDLE KIT (F20F-F130A)

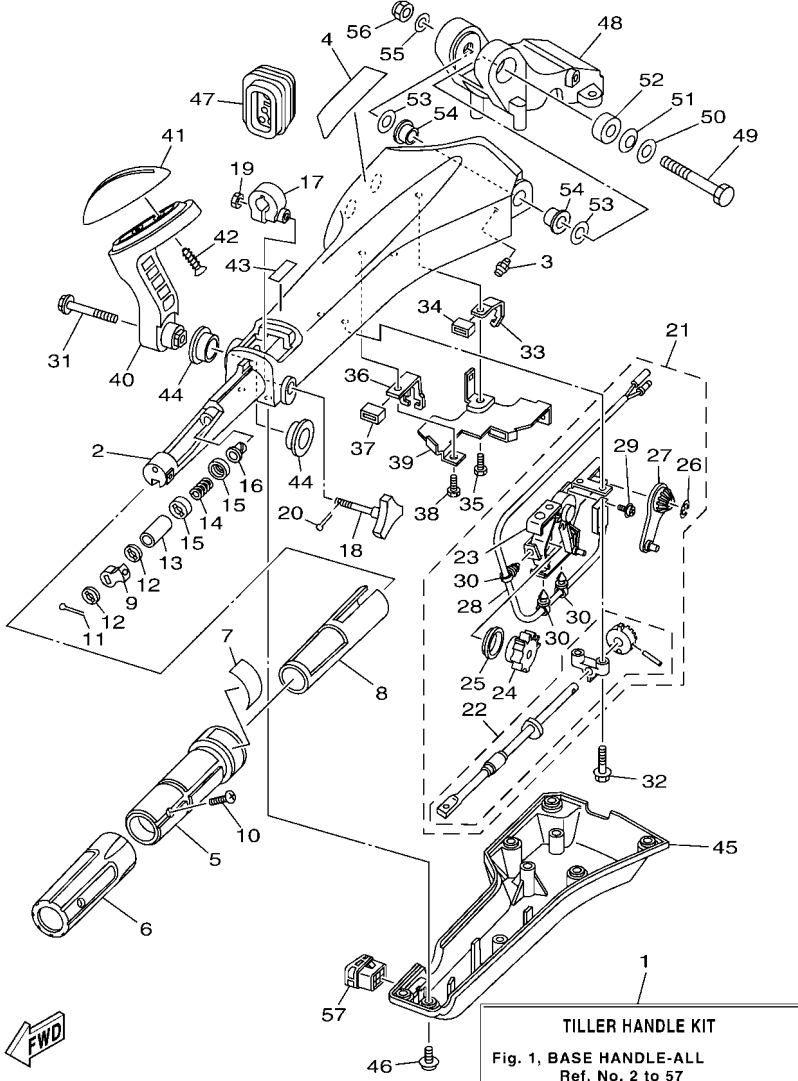

601S10S-R010

FIG. 1 BASE HANDLE - ALL

REF. NO.	PART NO.	DESCRIPTION	QTY	REMARKS
27	6X4-48261-00	.ARM, THROTTLE	1	
28	6X4-82540-00	.NEUTRAL SWITCH ASSY	1	
29	703-48129-00	.SCREW 3	2	
30	6X4-42821-00	.BAND, CLAMP	3	
31	97595-08540	BOLT, WITH WASHER	1	
32	97595-06530	BOLT, WITH WASHER	2	
33	6X4-48538-00	CLAMP, CABLE 1	1	
34	6X4-26367-00	PROTECTOR	1	
35	97095-06014	BOLT	1	
36	6X4-48538-10	CLAMP, CABLE 1	1	
37	6X4-26367-00	PROTECTOR	1	
38	97095-06014	BOLT	1	
39	6X4-42159-00	STAY	1	
40	6X4-44159-00-8D	HANDLE, GEAR SHIFT	1	
41	6X4-44173-00	LEVER, SHIFT CONTROL	1	
42	97780-60920	SCREW, TAPPING	2	
43	6G8-44191-00	INDICATOR, SHIFT	1	
44	90386-26MA3	BUSH	2	
45	6X4-42131-01	COVER, HANDLE STEERING	1	FOR USA,CAN
	6X4-42131-11	COVER, HANDLE STEERING	1	FOR EUR,OCE
46	97985-06216	SCREW, WITH WASHER	6	
47	6X4-42725-01	GROMMET	1	
48	63D-42121-22-8D	BRACKET	1	
49	90101-12014	BOLT	1	
50	92990-12200	WASHER, PLAIN	1	
51	90206-12M22	WASHER, WAVE	1	
52	90387-12M02	COLLAR	1	

6X4 TILLER HANDLE KIT (F20F-F130A)

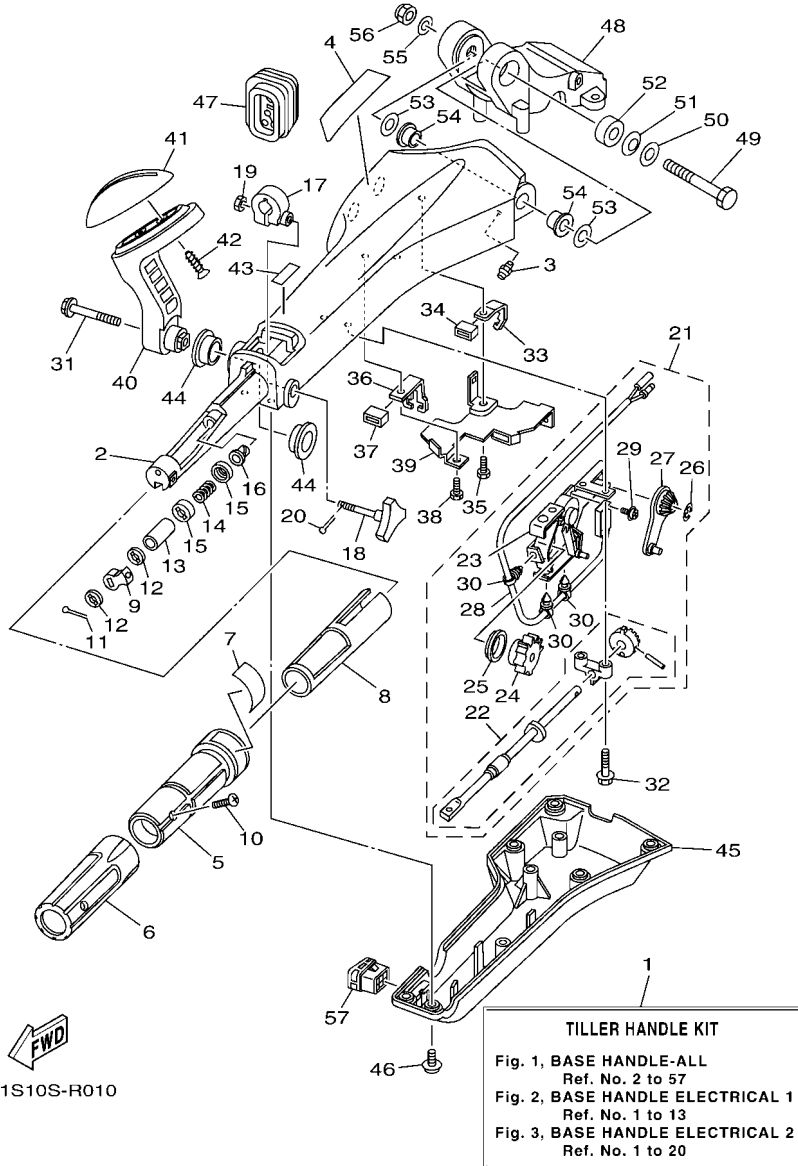

601S10S-R010



FIG. 1 BASE HANDLE - ALL

REF. NO.	PART NO.	DESCRIPTION	QTY		REMARKS
53	90201-12035	WASHER, PLATE	2		
54	90386-12003	BUSH	2		
55	92990-12600	WASHER, PLATE	1		
56	90185-12M12	NUT, SELF-LOCKING	1		
57	6X4-42728-10	CAP	1		



6X4 TILLER HANDLE KIT  
(F25C-F130A FOR USA,CANADA)

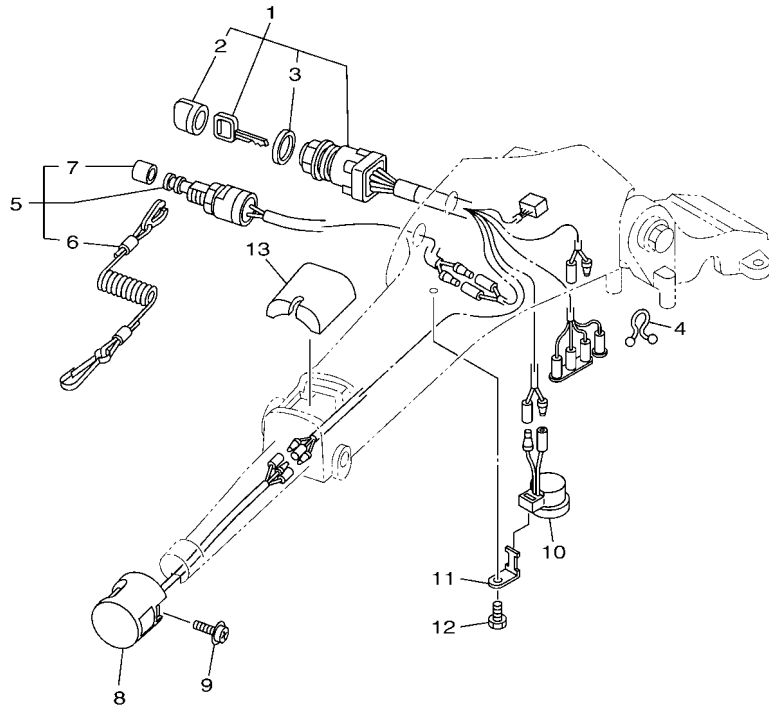

FIG. 2 BASE HANDLE ELECTRICAL 1

REF. NO.	PART NO.	DESCRIPTION	601S				REMARKS
1	6X4-82510-01	MAIN SWITCH ASSY	1				
2	676-82577-01	.CAP, KEY	1				
3	703-82532-00	.CAP	1				
4	90464-08M07	CLAMP	1				
5	69W-82575-00	ENGINE STOP SWITCH ASSY	1				
6	682-82556-00	.LANYARD, STOP SWITCH	1				
7	689-8257Y-00	.CAP	1				
8	6X4-82563-01	TRIM & TILT SWITCH ASSY	1				
9	97980-06216	SCREW, WITH WASHER	1				
10	6X4-83383-00	BUZZER	1				
11	6X4-83386-00	STAY, BUZZER	1				
12	97095-06014	BOLT	1				
13	6X4-81942-01	COVER	1				



601S10S-S020

**6X4 TILLER HANDLE KIT  
(F20F-F130A FOR EUROPE, OCEANIA)**

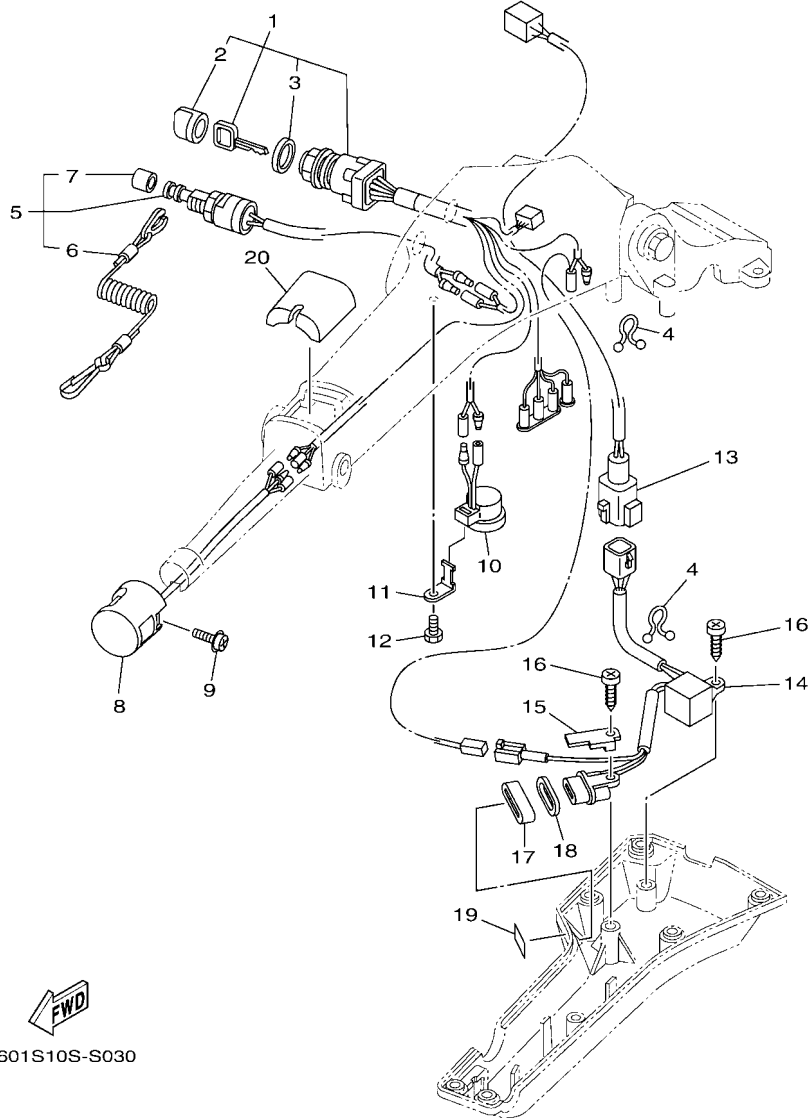

601S10S-S030

**FIG. 3 BASE HANDLE ELECTRICAL 2**

REF. NO.	PART NO.	DESCRIPTION	601S				REMARKS
1	6X4-82510-41	MAIN SWITCH ASSY	1				
2	676-82577-01	.CAP, KEY	1				
3	703-82532-00	.CAP	1				
4	90464-08M07	CLAMP	2				
5	69W-82575-00	ENGINE STOP SWITCH ASSY	1				
6	682-82556-00	.LANYARD, STOP SWITCH	1				
7	689-8257Y-00	.CAP	1				
8	6X4-82563-01	TRIM & TILT SWITCH ASSY	1				
9	97980-06216	SCREW, WITH WASHER	1				
10	6X4-83383-00	BUZZER	1				
11	6X4-83386-00	STAY, BUZZER	1				
12	97095-06014	BOLT	1				
13	6X4-83653-20	WIRE, LEAD (L:700MM)	1				
14	6C5-84301-00	PILOT LIGHT ASSY 1	1				
15	6X4-44114-00	STOPPER	1				
16	97780-60620	SCREW, TAPPING	2				
17	6X4-42727-00	GROMMET	1				
18	6H4-83589-00	GASKET	1				
19	6X4-85415-00	MARK, SIGNAL LAMP	1				
20	6X4-81942-01	COVER	1				

6X4 TILLER HANDLE KIT (F25A,F25B)

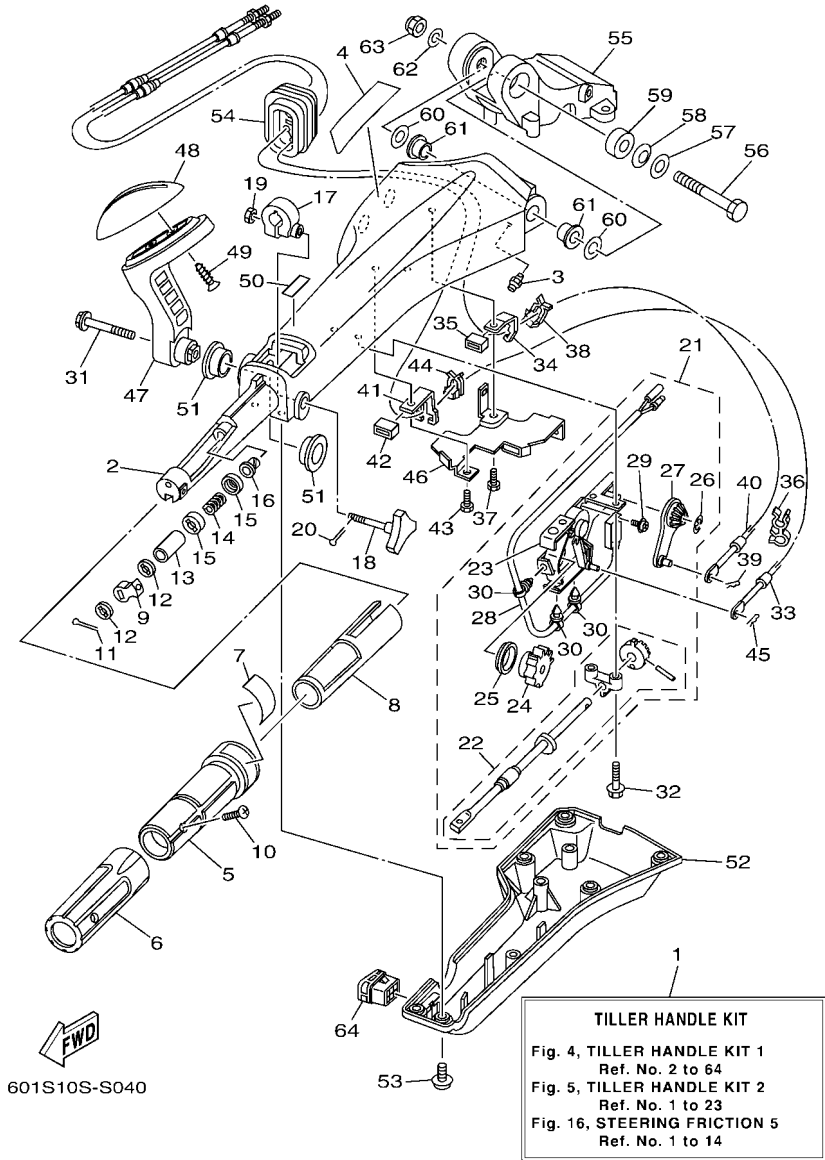

FIG. 4 TILLER HANDLE KIT 1

REF. NO.	PART NO.	DESCRIPTION	QTY	REMARKS
1	6X4-42103-0C	TILLER HANDLE KIT	1	LM FOR USA,CAN
2	6X4-42111-02-4D	HANDLE, STEERING	1	
3	93700-06M03	NIPPLE, GREASE	1	
4	6X4-48215-00	GRAPHIC	1	
5	6X4-42119-01	GRIP, STEERING HANDLE	1	
6	6X4-42177-00	RUBBER, HANDLE	1	
7	6X4-42137-00	INDICATOR, THROTTLE	1	
8	6X4-41291-00	BUSHING	1	
9	6X4-44139-01	COLLAR	1	
10	90152-05007	SCREW, COUNTERSUNK	1	
11	91490-20010	PIN, COTTER	1	
12	6X4-44177-00	WASHER	2	
13	6X4-42128-00	COLLAR, DISTANCE 1	1	
14	90501-23215	SPRING, COMPRESSION	1	
15	6X4-44188-00	WASHER	2	
16	90386-08032	BUSH	1	
17	63D-42126-00	FRICTION, STEERING HANDLE GRIP	1	
18	6X4-48154-00	KNOB, THROTTLE	1	
19	95380-06600	NUT, HEXAGON	1	
20	91490-20010	PIN, COTTER	1	
21	6X4-44100-01	SHIFT LINK ASSY	1	
22	6X4-42115-00	.SHAFT, STEERING HANDLE	1	
23	6X4-44102-00	.SHIFT ASSIST ASSY.	1	
24	6X4-47731-01	.GEAR, DRIVE	1	
25	6X4-44132-00	.BUSHING	1	
26	6X4-14137-00	.CLIP	1	
27	6X4-48261-00	.ARM, THROTTLE	1	

6X4 TILLER HANDLE KIT (F25A,F25B)

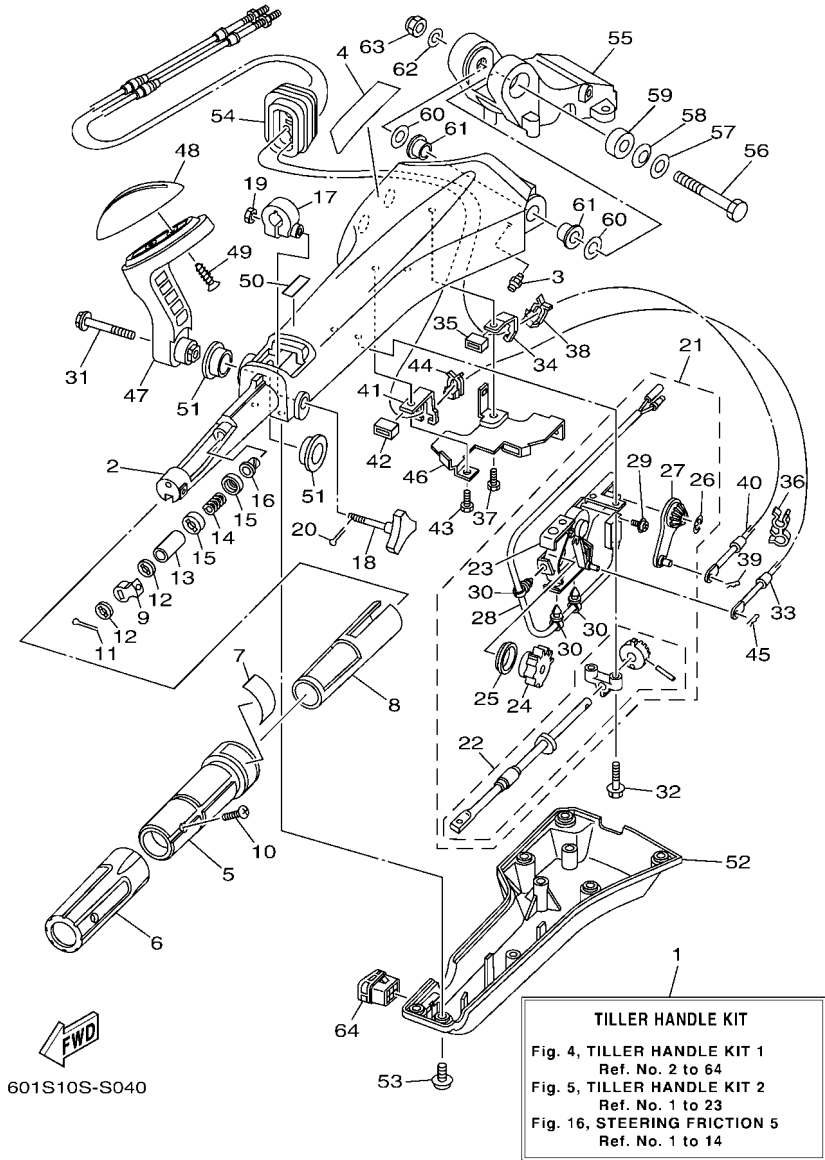

FIG. 4 TILLER HANDLE KIT 1

REF. NO.	PART NO.	DESCRIPTION	601S				REMARKS
28	6X4-82540-00	.NEUTRAL SWITCH ASSY	1				
29	703-48129-00	.SCREW 3	2				
30	6X4-42821-00	.BAND, CLAMP	3				
31	97595-08540	BOLT, WITH WASHER	1				
32	97595-06530	BOLT, WITH WASHER	2				
33	6H1-48321-21	CABLE	1				
34	6X4-48538-00	CLAMP, CABLE 1	1				
35	6X4-26367-00	PROTECTOR	1				
36	90464-09M42	CLAMP	1				
37	97095-06014	BOLT	1				
38	63D-48538-00	CLAMP, CABLE 1	1				
39	90468-10005	CLIP	1				
40	6H3-48321-02	CABLE	1				
41	6X4-48538-10	CLAMP, CABLE 1	1				
42	6X4-26367-00	PROTECTOR	1				
43	97095-06014	BOLT	1				
44	63D-48538-00	CLAMP, CABLE 1	1				
45	90468-10005	CLIP	1				
46	6X4-42159-00	STAY	1				
47	6X4-44159-00-4D	HANDLE, GEAR SHIFT	1				
48	6X4-44173-00	LEVER, SHIFT CONTROL	1				
49	97780-60920	SCREW, TAPPING	2				
50	6G8-44191-00	INDICATOR, SHIFT	1				
51	90386-26MA3	BUSH	2				
52	6X4-42131-01	COVER, HANDLE STEERING	1				
53	97985-06216	SCREW, WITH WASHER	6				
54	6X4-42725-01	GROMMET	1				

6X4 TILLER HANDLE KIT (F25A,F25B)

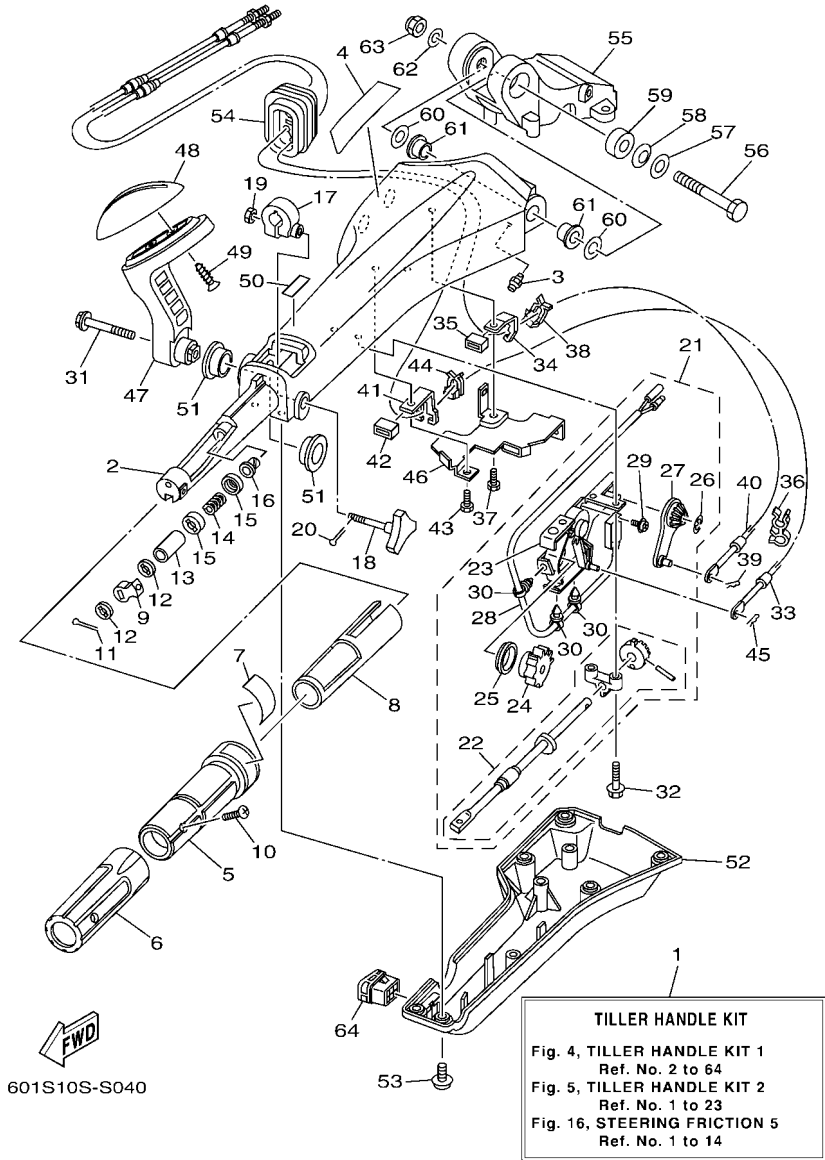
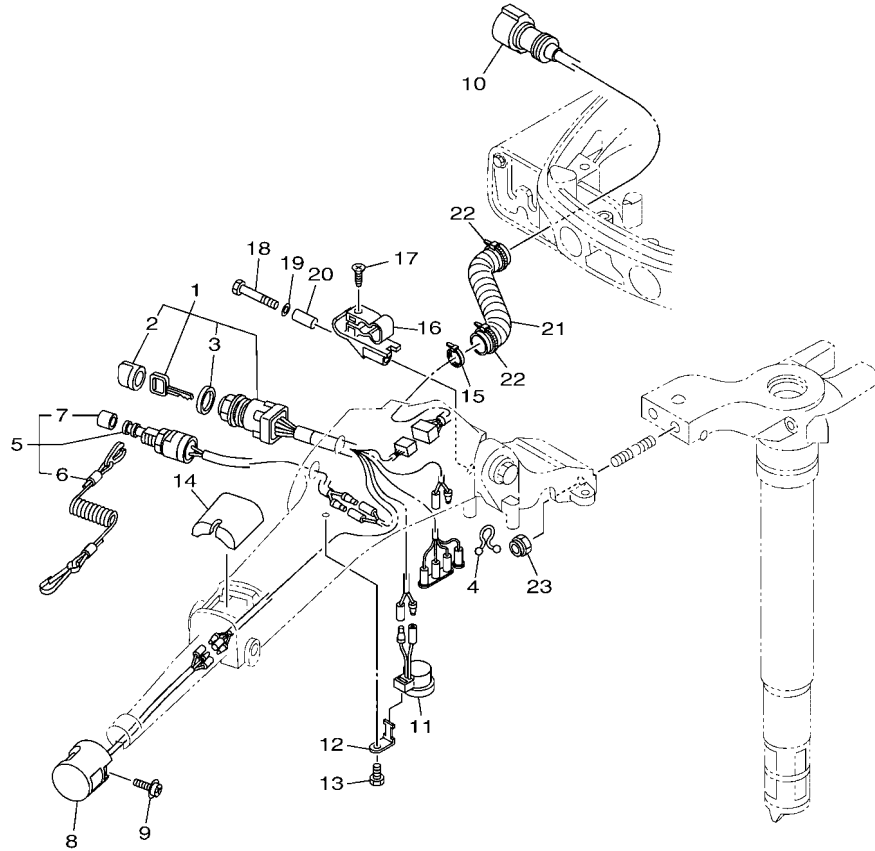

FIG. 4 TILLER HANDLE KIT 1

REF. NO.	PART NO.	DESCRIPTION	601S				REMARKS
55	65W-42121-11-4D	BRACKET	1				
56	90101-12014	BOLT	1				
57	92990-12200	WASHER, PLAIN	1				
58	90206-12M22	WASHER, WAVE	1				
59	90387-12M02	COLLAR	1				
60	90201-12035	WASHER, PLATE	2				
61	90386-12003	BUSH	2				
62	92990-12600	WASHER, PLATE	1				
63	90185-12M12	NUT, SELF-LOCKING	1				
64	6X4-42728-10	CAP	1				

6X4 TILLER HANDLE KIT (F25A, F25B FOR USA, CANADA)



  
601S10S-S050

FIG. 5 TILLER HANDLE KIT 2

REF. NO.	PART NO.	DESCRIPTION	601S				REMARKS
1	6X4-82510-01	MAIN SWITCH ASSY	1				
2	676-82577-01	.CAP, KEY	1				
3	703-82532-00	.CAP	1				
4	90464-08M07	CLAMP	1				
5	69W-82575-00	ENGINE STOP SWITCH ASSY	1				
6	682-82556-00	.LANYARD, STOP SWITCH	1				
7	689-8257Y-00	.CAP	1				
8	6X4-82563-01	TRIM & TILT SWITCH ASSY	1				
9	97980-06216	SCREW, WITH WASHER	1				
10	6X4-82586-10	EXT., WIRE HARNESS (L:950MM)	1				
11	6X4-83383-00	BUZZER	1				
12	6X4-83386-00	STAY, BUZZER	1				
13	97095-06014	BOLT	1				
14	6X4-81942-01	COVER	1				
15	90465-13M36	CLAMP	1				
16	62Y-82361-00	CLAMP, CORD	1				
17	90161-06M03	SCREW, TAPPING	1				
18	97095-06035	BOLT	1				
19	92995-06600	WASHER	1				
20	90387-06M26	COLLAR	1				
21	90447-22006	TUBE	1				
22	90465-13M24	CLAMP	2				
23	90185-10027	NUT, SELF-LOCKING	2				

**6X4 TILLER HANDLE FITTING KIT (F75B, VF90A, F90B, F115B, VF115A, F130A)**

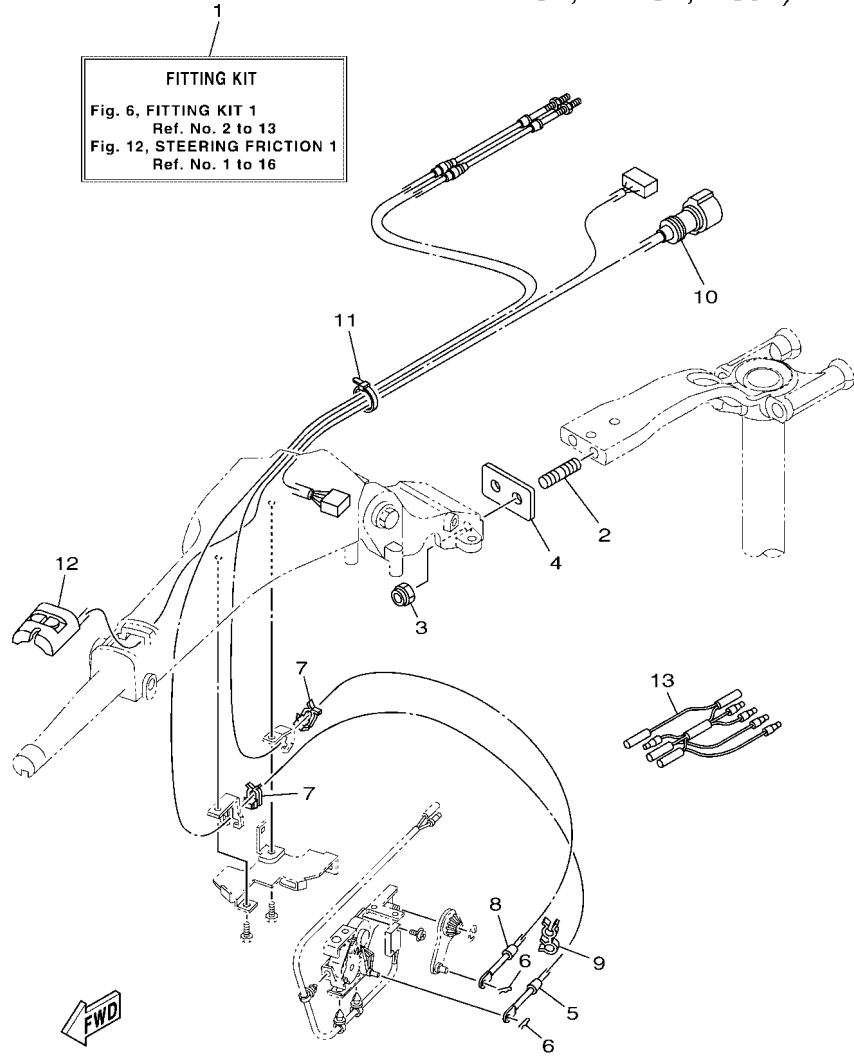

601S10S-S060

**FIG. 6 FITTING KIT 1**

REF. NO.	PART NO.	DESCRIPTION	601S				REMARKS
1	6X4-42102-H0	FITTING KIT	1				LM FOR USA,CAN
	6X4-42102-J0	FITTING KIT	1				LM FOR USA,CAN
	6X4-42102-C0	FITTING KIT	1				LM FOR EUR,OCE
2	90116-10063	BOLT, STUD	2				
3	90185-10027	NUT, SELF-LOCKING	2				
4	6EK-42121-00	BRACKET	1				
5	6EK-48321-00	CABLE	1				
6	90468-10005	CLIP	2				
7	63D-48538-00	CLAMP, CABLE 1	2				
8	6EK-26301-00	THROTTLE CABLE ASSY	1				FOR 6X4-42102-H0/C0
	6FP-26301-00	THROTTLE CABLE ASSY	1				FOR 6X4-42102-J0
9	90464-09M42	CLAMP	1				
10	6X4-82586-10	EXT., WIRE HARNESS (L:950MM)	1				
11	90465-13M24	CLAMP	1				
12	6X4-81860-00	SWITCH ASSY	1				
13	6X4-82521-00	WIRE, LEAD	1				FOR 6X4-42102-H0/J0

6X4 TILLER HANDLE FITTING KIT (F75B,F80B,  
VF90A,F100D)

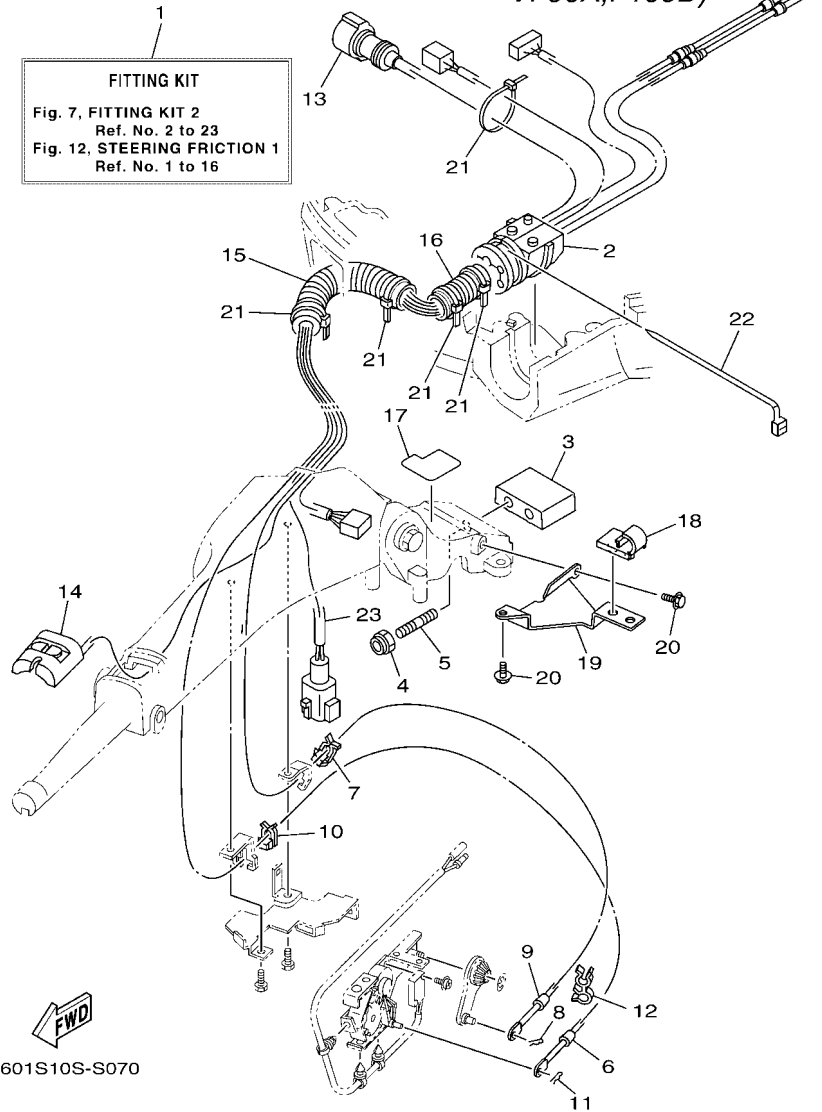
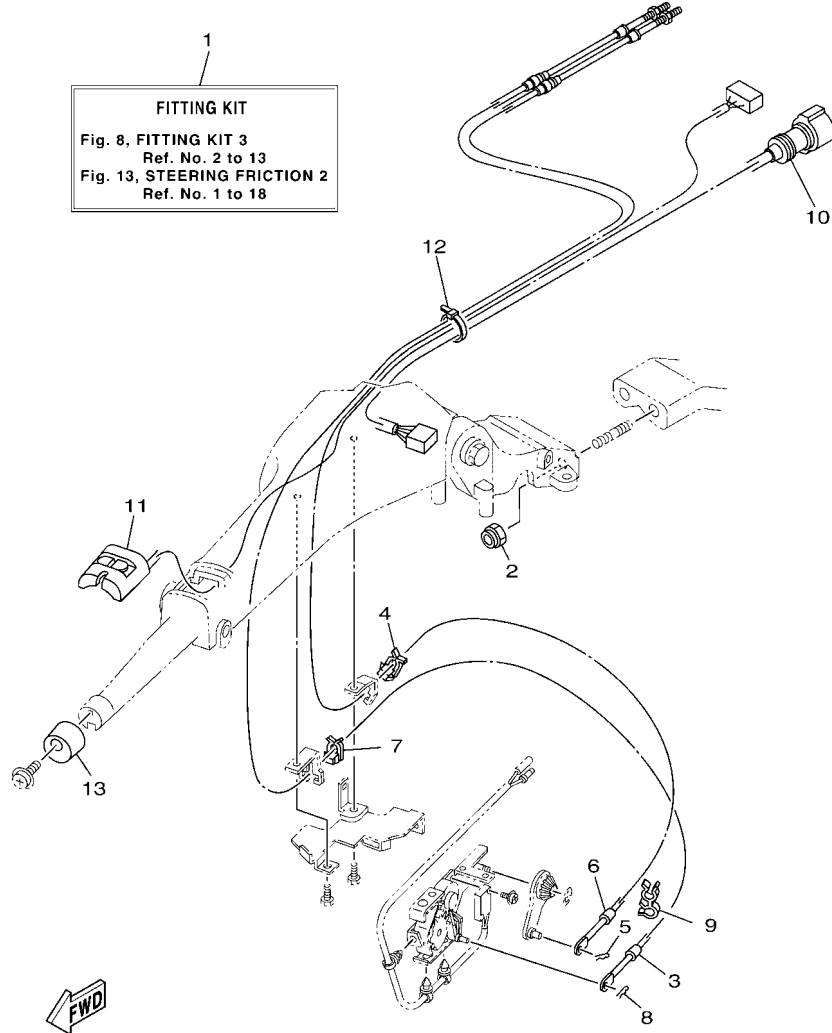

FIG. 7 FITTING KIT 2

REF. NO.	PART NO.	DESCRIPTION	601S	REMARKS
1	6X4-42102-11	FITTING KIT	1	LM FOR USA,CAN
	6X4-42102-A1	FITTING KIT	1	LM FOR EUR,OCE
2	68V-42725-10	GROMMET	1	
3	6X4-42121-00-8D	BRACKET	1	
4	90185-10027	NUT, SELF-LOCKING	2	
5	90116-10031	BOLT, STUD	2	
6	67G-48321-20	CABLE	1	
7	63D-48538-00	CLAMP, CABLE 1	1	
8	90468-10005	CLIP	1	
9	67G-26301-10	THROTTLE CABLE ASSY	1	
10	63D-48538-00	CLAMP, CABLE 1	1	
11	90468-10005	CLIP	1	
12	90464-09M42	CLAMP	1	
13	6X4-82586-20	EXT., WIRE HARNESS (L:1.25M)	1	
14	6X4-81860-00	SWITCH ASSY	1	
15	90447-22007	TUBE	1	
16	6K3-83557-00	TUBE	1	
17	6X4-42735-00	PROTECTOR	1	
18	63D-24367-00	CLAMP, FUEL PIPE 2	1	
19	6X4-24364-00	STAY	1	
20	97595-06516	BOLT, WITH WASHER	2	
21	90465-13M24	CLAMP	5	
22	90465-13M30	CLAMP	1	
23	6X4-83653-00	WIRE, LEAD (L:1250MM)	1	FOR EUR,OCE



**6X4 TILLER HANDLE FITTING KIT**  
 (F50B,F50H,T50B,FT50J,F60B,F60F,T60B,FT60G,F70A)



601S10S-S080

**FIG. 8 FITTING KIT 3**

REF. NO.	PART NO.	DESCRIPTION	601S				REMARKS
1	6X4-42102-23	FITTING KIT	1				LM FOR USA,CAN
	6X4-42102-92	FITTING KIT	1				LM FOR EUR,OCE
2	90185-10027	NUT, SELF-LOCKING	2				
3	67C-48321-11	CABLE	1				
4	63D-48538-00	CLAMP, CABLE 1	1				
5	90468-10005	CLIP	1				
6	69W-26301-00	THROTTLE CABLE ASSY	1				
7	63D-48538-00	CLAMP, CABLE 1	1				
8	90468-10005	CLIP	1				
9	90464-09M42	CLAMP	1				
10	6X4-82586-10	EXT., WIRE HARNESS (L:950MM)	1				
11	6X4-81860-00	SWITCH ASSY	1				
12	90465-13M36	CLAMP	1				
13	6X4-42728-00	CAP	1				FOR EUR,OCE

**6X4 TILLER HANDLE FITTING KIT  
(F30A, F30B, F40A, F40F)**

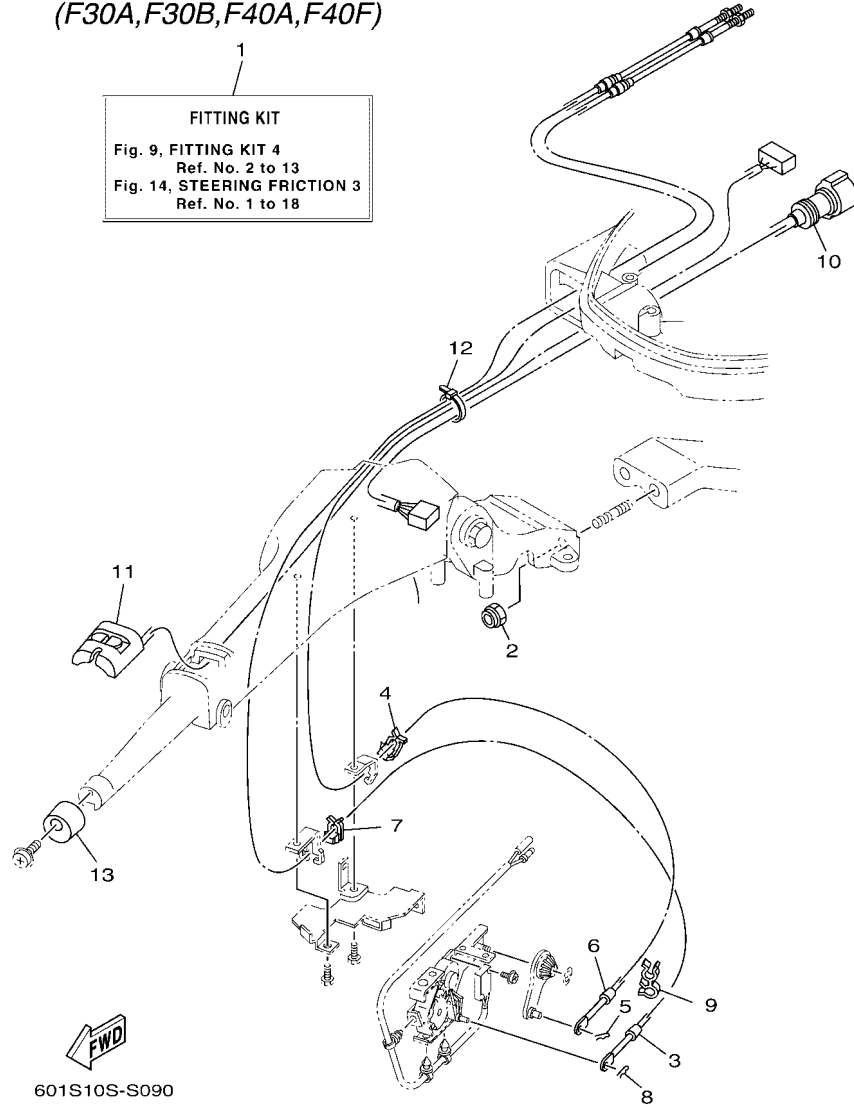

**FIG. 9 FITTING KIT 4**

REF. NO.	PART NO.	DESCRIPTION	601S				REMARKS
1	6X4-42102-71	FITTING KIT	1				LM FOR USA,CAN
	6X4-42102-82	FITTING KIT	1				LM FOR EUR,OCE
2	90185-10027	NUT, SELF-LOCKING	2				
3	67C-48321-11	CABLE	1				
4	63D-48538-00	CLAMP, CABLE 1	1				
5	90468-10005	CLIP	1				
6	69W-26301-00	THROTTLE CABLE ASSY	1				
7	63D-48538-00	CLAMP, CABLE 1	1				
8	90468-10005	CLIP	1				
9	90464-09M42	CLAMP	1				
10	6X4-82586-10	EXT., WIRE HARNESS (L:950MM)	1				
11	6X4-81860-00	SWITCH ASSY	1				
12	90465-13M36	CLAMP	1				
13	6X4-42728-00	CAP	1				FOR EUR,OCE

6X4 TILLER HANDLE FITTING KIT (F20F, F25C, F25G)

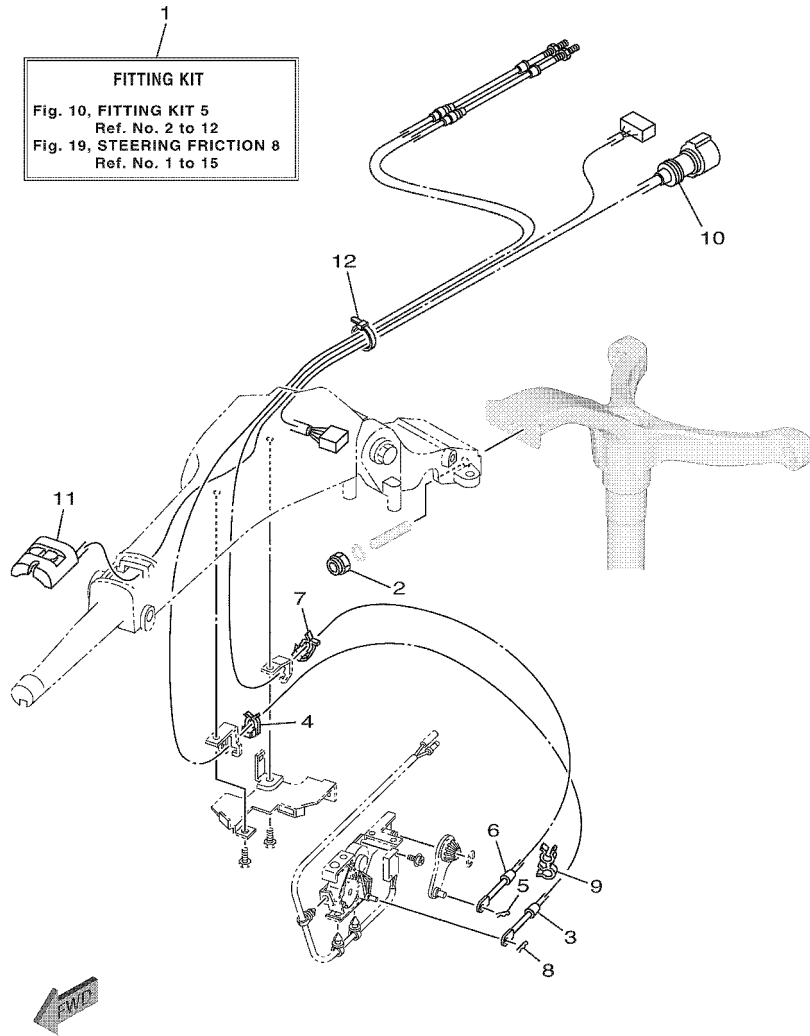

601S10SDS100

FIG. 10 FITTING KIT 5

REF. NO.	PART NO.	DESCRIPTION	601S				REMARKS
1	6X4-42102-E0	FITTING KIT	1				LM FOR USA,CAN
	6X4-42102-F0	FITTING KIT	1				LM FOR EUR,OCE
2	90185-10027	NUT, SELF-LOCKING	2				
3	63D-48321-11	CABLE	1				
4	63D-48538-00	CLAMP, CABLE 1	1				
5	90468-10005	CLIP	1				
6	6FM-26301-10	THROTTLE CABLE ASSY	1				
7	63D-48538-00	CLAMP, CABLE 1	1				
8	90468-10005	CLIP	1				
9	90464-09M42	CLAMP	1				
10	6X4-82586-10	EXT., WIRE HARNESS (L:950MM)	1				
11	6X4-81860-00	SWITCH ASSY	1				
12	90465-13M39	CLAMP	1				

6X4 TILLER HANDLE FITTING KIT (F75B,F80D,F90B,  
VF90A,F100F)

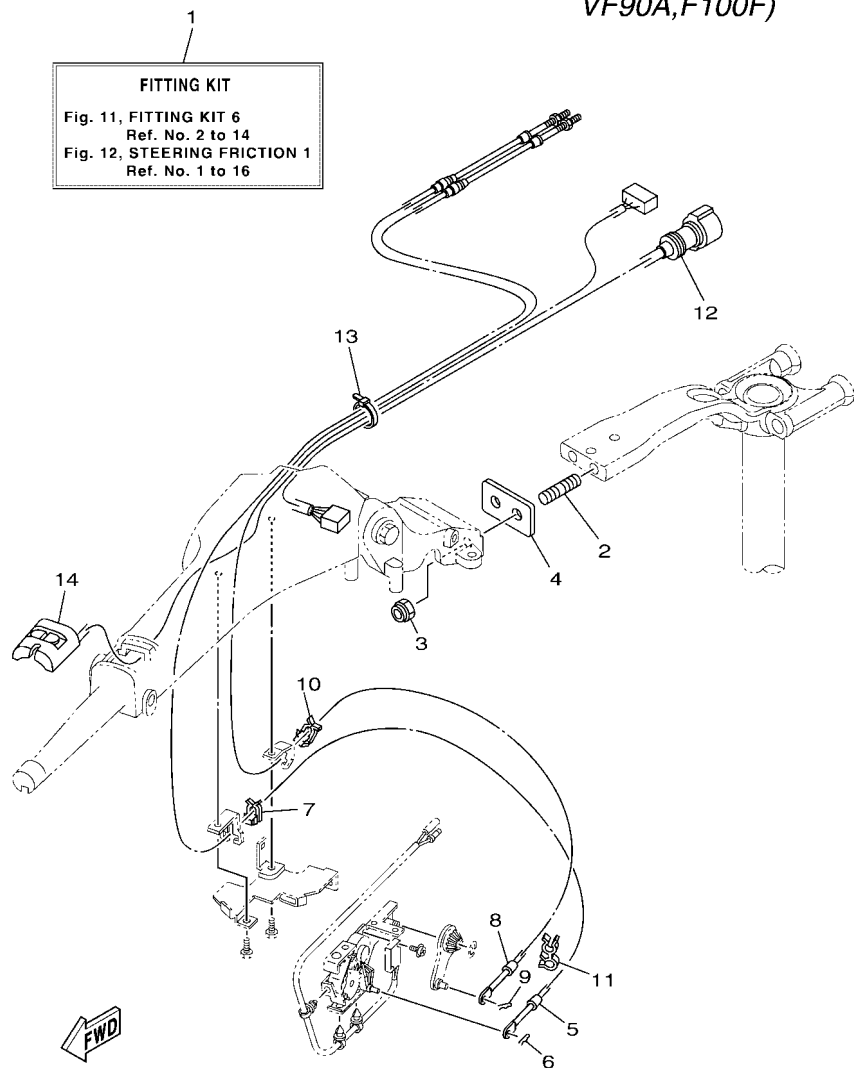

601S10S-S110

FIG. 11 FITTING KIT 6

REF. NO.	PART NO.	DESCRIPTION	601S				REMARKS
1	6X4-42102-G0	FITTING KIT	1				LM FOR EUR,OCE
2	90116-10063	BOLT, STUD	2				
3	90185-10027	NUT, SELF-LOCKING	2				
4	6EK-42121-00	BRACKET	1				
5	6EK-48321-00	CABLE	1				
6	90468-10005	CLIP	1				
7	63D-48538-00	CLAMP, CABLE 1	1				
8	6FP-26301-00	THROTTLE CABLE ASSY	1				
9	90468-10005	CLIP	1				
10	63D-48538-00	CLAMP, CABLE 1	1				
11	90464-09M42	CLAMP	1				
12	6X4-82586-10	EXT., WIRE HARNESS (L:950MM)	1				
13	90465-13M24	CLAMP	1				
14	6X4-81860-00	SWITCH ASSY	1				

### STEERING FRICTION

Part No.	Applicable model
67G-42508-10	F75B, VF90A, F90B, F115B (F115B), VF115A, F130A (F130A)

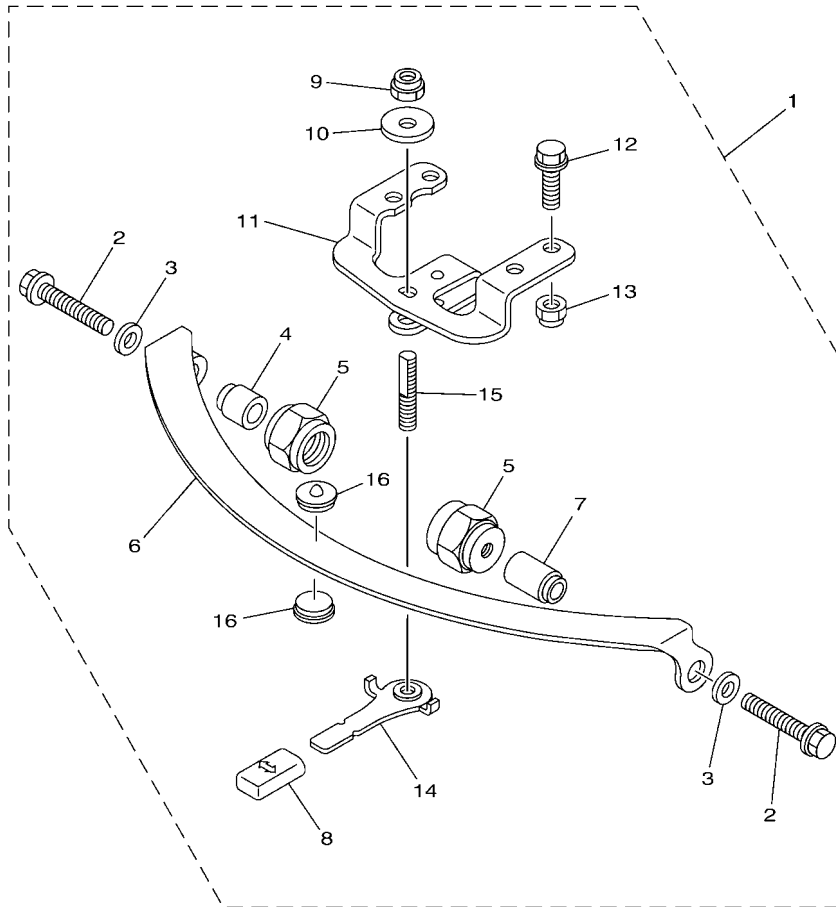

601S10S-S120

**FIG. 12 STEERING FRICTION 1**

REF. NO.	PART NO.	DESCRIPTION	601S				REMARKS
1	67G-42508-10	STEERING FRICTION ASSY	1				
2	90119-08M74	.BOLT, WITH WASHER	2				
3	90201-08M01	.WASHER, PLATE	2				
4	67G-42541-00	.PIPE 1	1				
5	67G-42546-00	.NUT	2				
6	63D-42527-00	.PLATE, FRICTION	1				
7	67G-42541-10	.PIPE 1	1				
8	682-43318-01	.COVER	1				
9	90185-10M14	.NUT, SELF-LOCKING	1				
10	90201-10M76	.WASHER, PLATE	1				
11	6X4-42526-00	.PLATE, FRICTION	1				
12	97595-08025	.BOLT, WITH WASHER	2				
13	90185-08057	.NUT, SELF-LOCKING	2				
14	67G-42561-00	.KNOB, STEERING LOCK	1				
15	67G-42562-00	.SHAFT, STEERING LOCK	1				
16	63D-42528-00	.PLATE, FRICTION	2				

### STEERING FRICTION

Part No.	Applicable model
6C5-42508-01	F40H, F40G, F50H (F50B), FT50J (T50B), F60F (F60B), FT60G (T60B), F70A(F70A)

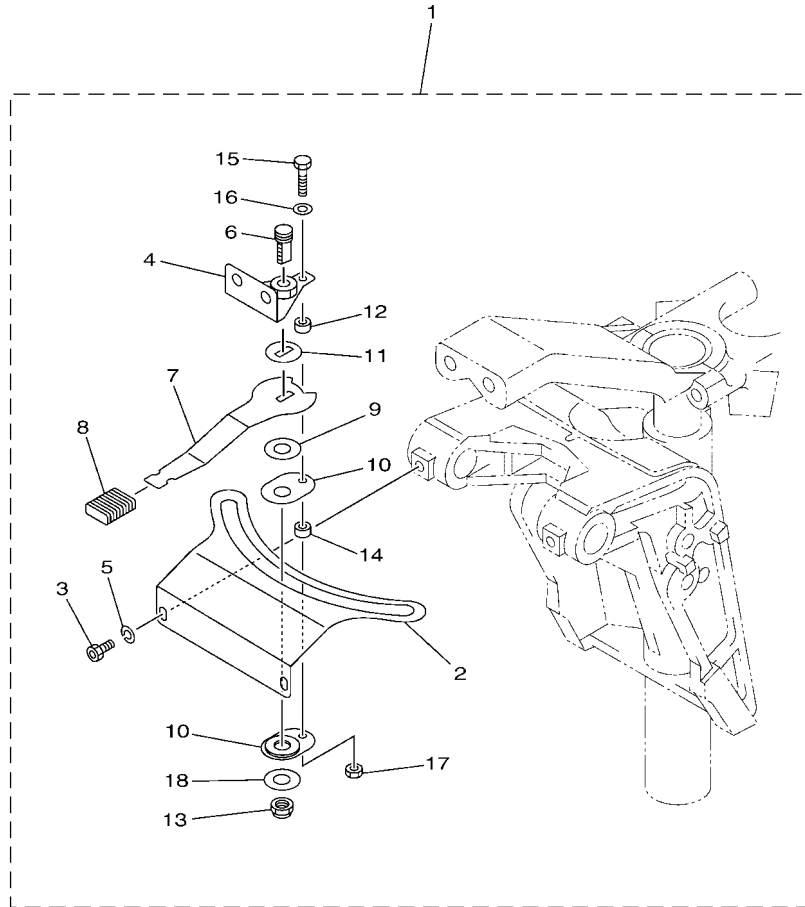

  
601S10S-S130

**FIG. 13 STEERING FRICTION 2**

REF. NO.	PART NO.	DESCRIPTION	601S				REMARKS
1	6C5-42508-01	STEERING FRICTION ASSY	1				
2	6C5-42527-00	.PLATE, FRICTION	1				
3	90109-06M88	.BOLT	2				
4	67C-42525-00	.PLATE, FRICTION	1				
5	92990-06100	.WASHER, SPRING	2				
6	67C-42562-00	.SHAFT, STEERING LOCK	1				
7	67C-42561-00	.KNOB, STEERING LOCK	1				
8	689-43633-00	.COVER, TILT LEVER	1				
9	90202-10M56	.WASHER, PLATE	1				
10	65W-42528-00	.PLATE, FRICTION	2				
11	90209-10M26	.WASHER	1				
12	90387-05053	.COLLAR	1				
13	90185-10M14	.NUT, SELF-LOCKING	1				
14	90387-05054	.COLLAR	1				
15	97095-05020	.BOLT	1				
16	92995-05600	.WASHER	1				
17	95380-05600	.NUT	1				
18	90201-106M5	.WASHER, PLATE	1				

### STEERING FRICTION

Part No.	Applicable model
67C-42508-04	F30B (F30A), F40F (F40A)

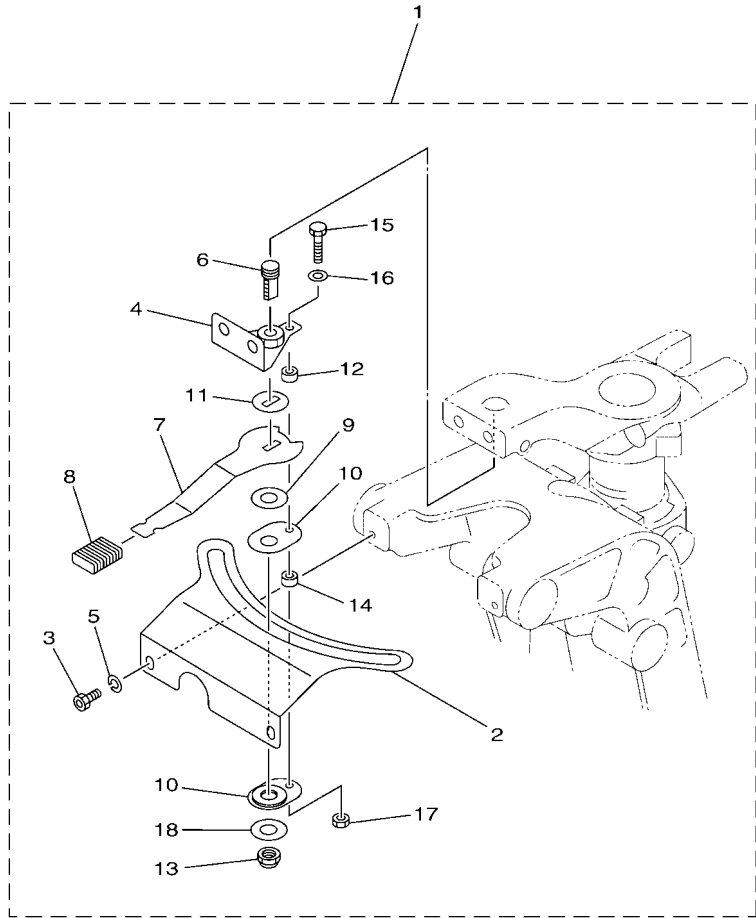

601S10S-S140

**FIG. 14 STEERING FRICTION 3**

REF. NO.	PART NO.	DESCRIPTION	601S				REMARKS
1	67C-42508-04	STEERING FRICTION ASSY	1				
2	67C-42527-03	.PLATE, FRICTION	1				
3	90109-06M88	.BOLT	2				
4	67C-42525-00	.PLATE, FRICTION	1				
5	92990-06100	.WASHER, SPRING	2				
6	67C-42562-00	.SHAFT, STEERING LOCK	1				
7	67C-42561-00	.KNOB, STEERING LOCK	1				
8	689-43633-00	.COVER, TILT LEVER	1				
9	90202-10M56	.WASHER, PLATE	1				
10	65W-42528-00	.PLATE, FRICTION	2				
11	90209-10M26	.WASHER	1				
12	90387-05053	.COLLAR	1				
13	90185-10M14	.NUT, SELF-LOCKING	1				
14	90387-05054	.COLLAR	1				
15	97095-05020	.BOLT	1				
16	92995-05600	.WASHER	1				
17	95380-05600	.NUT	1				
18	90201-106M5	.WASHER, PLATE	1				

### STEERING FRICTION

Part No.	Applicable model
6AH-42508-01	F8F(F8B), FT8G, F9.9J(F9.9B), F9.9H, FT9.9L(T9.9B), F15C (F15A), F20B (F20A), F20C
6AH-42508-11	FT9.9L(T9.9B), F15C (F15A), F20B (F20A)

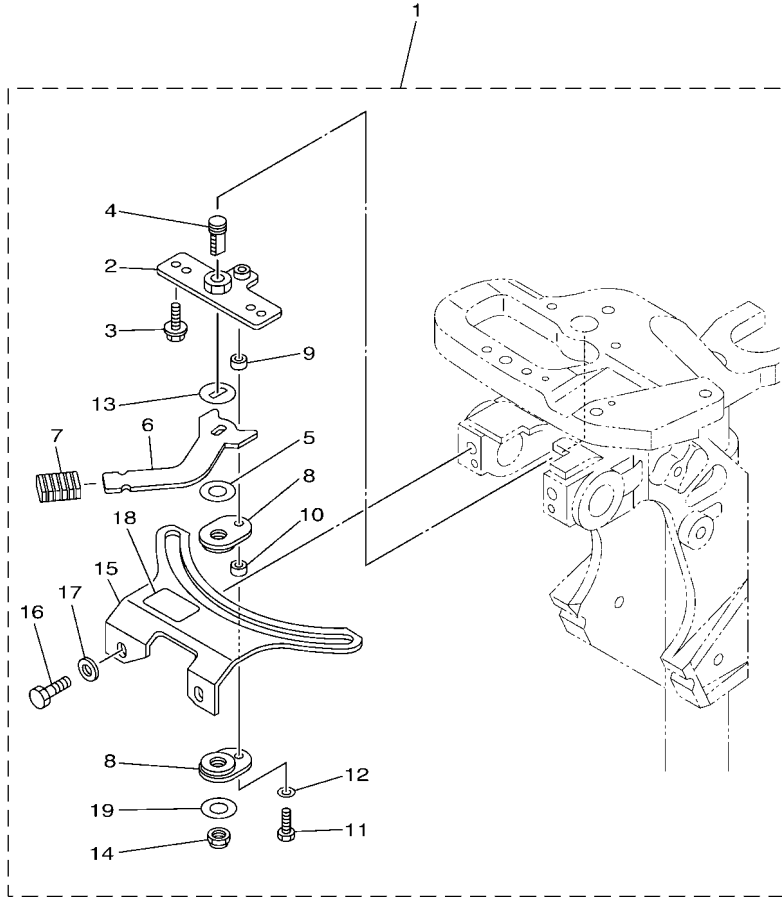

601S10S-Q140

**FIG. 15 STEERING FRICTION 4**

REF. NO.	PART NO.	DESCRIPTION	601S				REMARKS
1	6AH-42508-01	STEERING FRICTION ASSY	1				UR
	6AH-42508-11	STEERING FRICTION ASSY	1				UR
2	68T-42525-01	.PLATE, FRICTION	1				
3	90119-05018	.BOLT, WITH WASHER	2				
4	67C-42562-00	.SHAFT, STEERING LOCK	1				
5	90202-10M56	.WASHER, PLATE	1				
6	68T-42561-00	.KNOB, STEERING LOCK	1				
7	689-43633-00	.COVER, TILT LEVER	1				
8	65W-42528-00	.PLATE, FRICTION	2				
9	90387-05053	.COLLAR	1				
10	90387-05054	.COLLAR	1				
11	97095-05020	.BOLT	1				
12	92995-05600	.WASHER	1				
13	90209-10M26	.WASHER	1				
14	90185-10M14	.NUT, SELF-LOCKING	1				
15	6AH-42527-00	.PLATE, FRICTION	1				
16	90101-08022	.BOLT	2				
17	90201-08065	.WASHER, PLATE	2				
18	68T-43155-00	.MARK 1	1				FOR 6AH-42508-01
19	90201-106M5	.WASHER, PLATE	1				



### STEERING FRICTION

Part No.	Applicable model
65W-42508-00	F25D (F25A/F25B), (E)40X

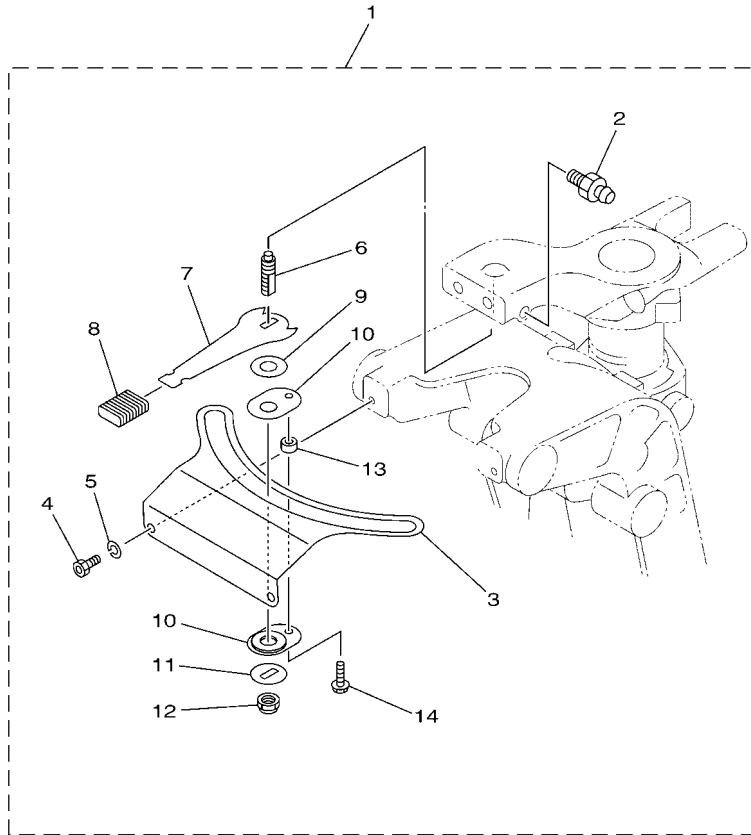

601S10S-M180

**FIG. 16 STEERING FRICTION 5**

REF. NO.	PART NO.	DESCRIPTION	601S				REMARKS
1	65W-42508-00	STEERING FRICTION ASSY	1				
2	93700-06M03	.NIPPLE, GREASE	1				
3	65W-42527-00	.PLATE, FRICTION	1				
4	90109-06M88	.BOLT	2				
5	92990-06100	.WASHER, SPRING	2				
6	65W-42562-00	.SHAFT, STEERING LOCK	1				
7	65W-42561-00	.KNOB, STEERING LOCK	1				
8	689-43633-00	.COVER, TILT LEVER	1				
9	90202-10M56	.WASHER, PLATE	1				
10	65W-42528-00	.PLATE, FRICTION	2				
11	90209-10M26	.WASHER	1				
12	90185-10M14	.NUT, SELF-LOCKING	1				
13	90387-05054	.COLLAR	1				
14	90109-05M89	.BOLT	1				

### STEERING FRICTION

Part No.	Applicable model
63D-42508-00	FT50C, F50D, 40V, 50H

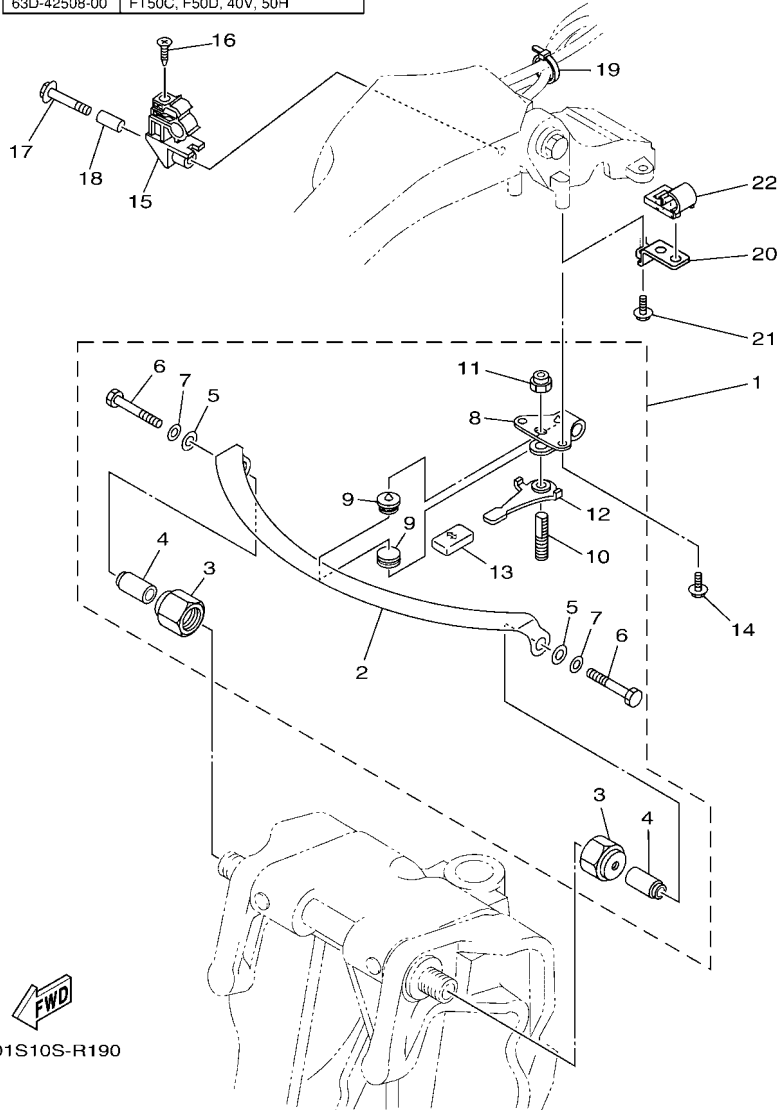

601S10S-R190

**FIG. 17 STEERING FRICTION 6**

REF. NO.	PART NO.	DESCRIPTION	601S				REMARKS
1	63D-42508-00	STEERING FRICTION ASSY	1				
2	63D-42527-00	.PLATE, FRICTION	1				
3	63D-42546-00	.NUT	2				
4	63D-42541-00	.PIPE 1	2				
5	90201-08M01	.WASHER, PLATE	2				
6	97095-08050	.BOLT	2				
7	92990-08600	.WASHER, PLATE	2				
8	63D-42526-00	.PLATE, FRICTION	1				
9	63D-42528-00	.PLATE, FRICTION	2				
10	63D-42562-00	.SHAFT, STEERING LOCK	1				
11	90185-10M01	.NUT, SELF-LOCKING	1				
12	63D-42561-00	.KNOB, STEERING LOCK	1				
13	682-43318-01	.COVER	1				
14	97595-06516	BOLT, WITH WASHER	2				
15	63D-82361-00	CLAMP, CORD	1				
16	90161-06M00	SCREW, TAPPING	1				
17	97595-06535	BOLT, WITH WASHER	1				
18	90387-06M26	COLLAR	1				
19	90465-13M36	CLAMP	1				
20	63D-24364-10	STAY	1				
21	97595-06516	BOLT, WITH WASHER	1				
22	63D-24367-00	CLAMP, FUEL PIPE 2	1				

### STEERING FRICTION

Part No.	Applicable model
692-42508-01	E55D, 60F, 70B, 90A

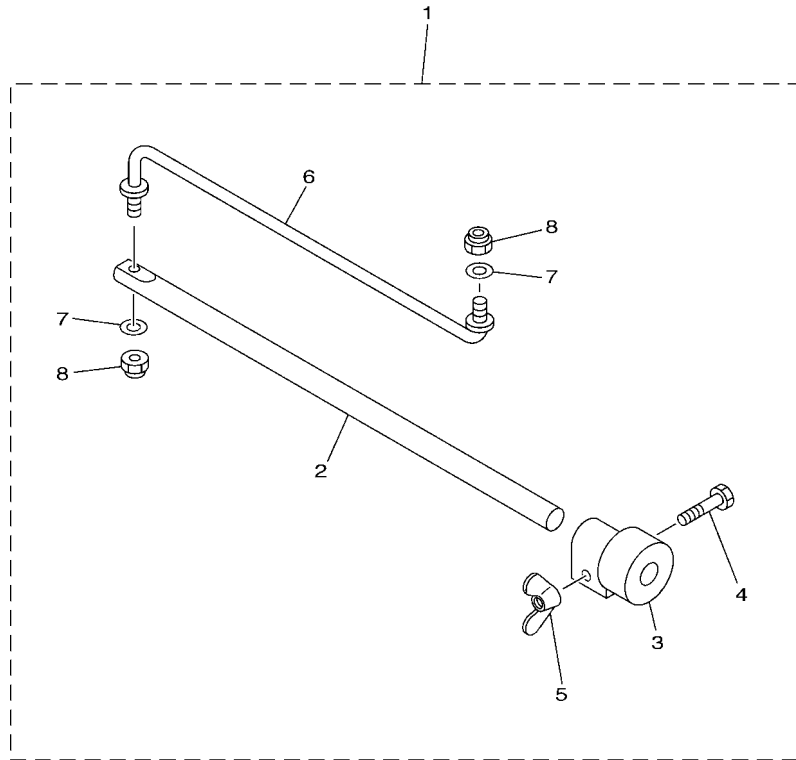

601S10S-R200

### FIG. 18 STEERING FRICTION 7

REF. NO.	PART NO.	DESCRIPTION	601S				REMARKS
1	692-42508-01	STEERING FRICTION ASSY	1				
2	663-42518-00	.SHAFT, FRICTION	1				
3	663-42528-00	.PLATE, FRICTION	1				
4	97080-06035	.BOLT	1				
5	90175-06003	.NUT, WING	1				
6	692-42515-01	.ROD, STEERING LINK	1				
7	92990-08600	.WASHER, PLATE	2				
8	90185-08057	.NUT, SELF-LOCKING	2				

### STEERING FRICTION

Part No.	Applicable model
6FM-42508-10	F20F, F25G(F25C)

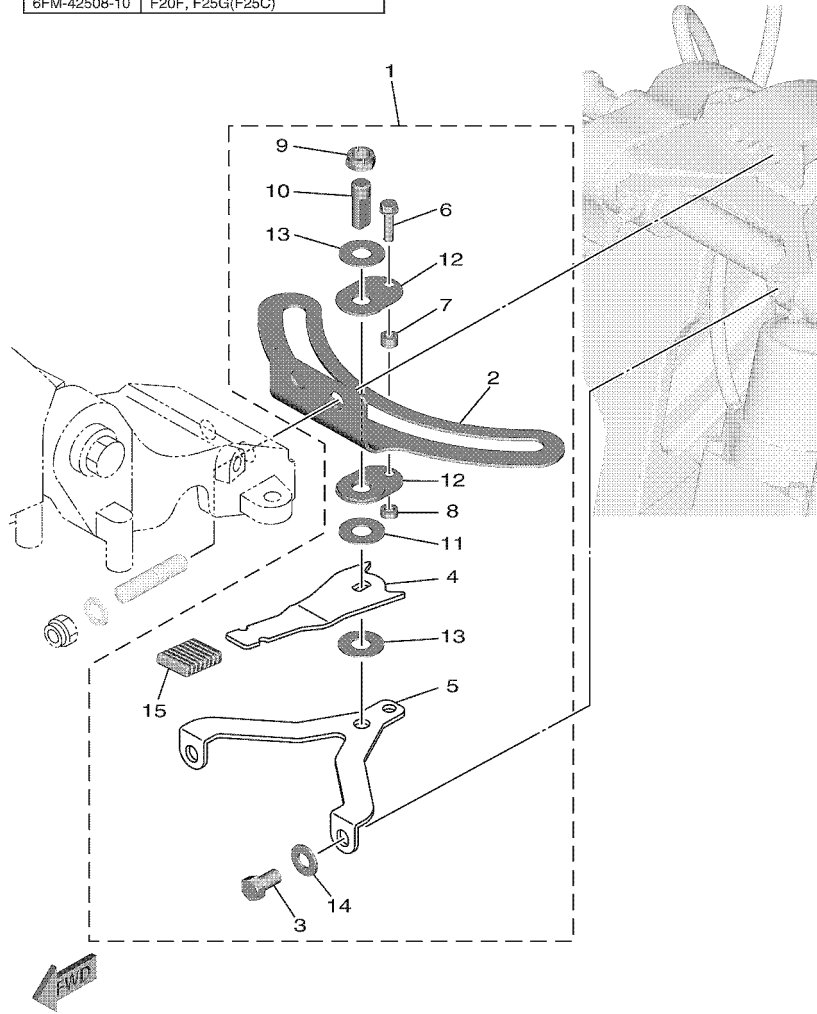

**FIG. 19 STEERING FRICTION 8**

REF. NO.	PART NO.	DESCRIPTION	601S				REMARKS
1	6FM-42508-10	STEERING FRICTION ASSY	1				
2	6FM-42527-00	.PLATE, FRICTION	1				
3	90109-08M91	.BOLT	2				
4	6FM-42561-10	.KNOB, STEERING LOCK	1				
5	6FM-42525-10	.PLATE, FRICTION	1				
6	97595-05520	.BOLT, WITH WASHER	1				
7	90387-05054	.COLLAR	1				
8	90387-05053	.COLLAR	1				
9	90185-10M14	.NUT, SELF-LOCKING	1				
10	67C-42562-00	.SHAFT, STEERING LOCK	1				
11	90202-10M56	.WASHER, PLATE	1				
12	65W-42528-00	.PLATE, FRICTION	2				
13	90201-106M5	.WASHER, PLATE	2				
14	92995-08200	.WASHER	2				
15	689-43633-00	.COVER, TILT LEVER	1				

NUMERICAL INDEX

PART NO.	REF. NO.	PART NO.	REF. NO.	PART NO.	REF. NO.	PART NO.	REF. NO.	PART NO.	REF. NO.	PART NO.	REF. NO.
6X4-14137-00	1 - 26	6X4-42128-00	4 - 13	65W-42561-00	16 - 7	6X4-44188-00	4 - 15	63D-82361-00	17 - 15	90109-06M88	13 - 3
	4 - 26	6X4-42131-01	1 - 45	67C-42561-00	13 - 7	6G8-44191-00	1 - 43	6X4-82510-01	2 - 1		14 - 3
6X4-24364-00	7 - 19		4 - 52		14 - 7		4 - 50		5 - 1		16 - 4
63D-24364-10	17 - 20	6X4-42131-11	1 - 45	67G-42561-00	12 - 14	6X4-47731-01	1 - 24	6X4-82510-41	3 - 1	90109-08M91	19 - 3
63D-24367-00	7 - 18	6X4-42137-00	1 - 7	68T-42561-00	15 - 6		4 - 24	6X4-82521-00	6 - 13	90116-10031	7 - 5
	17 - 22		4 - 7	6FM-42561-10	19 - 4	703-48129-00	1 - 29	703-82532-00	2 - 3	90116-10063	6 - 2
69W-26301-00	8 - 6	6X4-42159-00	1 - 39	63D-42562-00	17 - 10		4 - 29		3 - 3		11 - 2
	9 - 6		4 - 46	65W-42562-00	16 - 6	6X4-48154-00	1 - 18		5 - 3	90119-05018	15 - 3
6EK-26301-00	6 - 8	6X4-42177-00	1 - 6	67C-42562-00	13 - 6		4 - 18	6X4-82540-00	1 - 28	90119-08M74	12 - 2
6FP-26301-00	6 - 8		4 - 6		14 - 6	6X4-48215-00	1 - 4		4 - 28	90152-05007	1 - 10
	11 - 8	63D-42508-00	17 - 1		15 - 4		4 - 4	682-82556-00	2 - 6		4 - 10
67G-26301-10	7 - 9	65W-42508-00	16 - 1		19 - 10	6X4-48261-00	1 - 27		3 - 6	90161-06M00	17 - 16
6FM-26301-10	10 - 6	692-42508-01	18 - 1	67G-42562-00	12 - 15		4 - 27		5 - 6	90161-06M03	5 - 17
6X4-26367-00	1 - 34	6AH-42508-01	15 - 1	6X4-42725-01	1 - 47	6EK-48321-00	6 - 5	6X4-82563-01	2 - 8	90175-06003	18 - 5
	1 - 37	6C5-42508-01	13 - 1		4 - 54		11 - 5		3 - 8	90185-08057	12 - 13
	4 - 35	67C-42508-04	14 - 1	68V-42725-10	7 - 2	6H3-48321-02	4 - 40		5 - 8		18 - 8
	4 - 42	67G-42508-10	12 - 1	6X4-42727-00	3 - 17	63D-48321-11	10 - 3	69W-82575-00	2 - 5	90185-10027	5 - 23
6X4-41291-00	1 - 8	6FM-42508-10	19 - 1	6X4-42728-00	8 - 13	67C-48321-11	8 - 3		3 - 5		6 - 3
	4 - 8	6AH-42508-11	15 - 1		9 - 13		9 - 3		5 - 5		7 - 4
6X4-42102-11	7 - 1	692-42515-01	18 - 6	6X4-42728-10	1 - 57	67G-48321-20	7 - 6	676-82577-01	2 - 2		8 - 2
6X4-42102-23	8 - 1	663-42518-00	18 - 2		4 - 64	6H1-48321-21	4 - 33		3 - 2		9 - 2
6X4-42102-71	9 - 1	67C-42525-00	13 - 4	6X4-42735-00	7 - 17	63D-48538-00	4 - 38		5 - 2		10 - 2
6X4-42102-82	9 - 1		14 - 4	6X4-42821-00	1 - 30		4 - 44	689-8257Y-00	2 - 7		11 - 3
6X4-42102-92	8 - 1	68T-42525-01	15 - 2		4 - 30		6 - 7		3 - 7	90185-10M01	17 - 11
6X4-42102-A1	7 - 1	6FM-42525-10	19 - 5	68T-43155-00	15 - 18		7 - 7		5 - 7	90185-10M14	12 - 9
6X4-42102-C0	6 - 1	63D-42526-00	17 - 8	682-43318-01	12 - 8		7 - 10	6X4-82586-10	5 - 10		13 - 13
6X4-42102-E0	10 - 1	6X4-42526-00	12 - 11		17 - 13		8 - 4		6 - 10		14 - 13
6X4-42102-F0	10 - 1	63D-42527-00	12 - 6	689-43633-00	13 - 8		8 - 7		8 - 10		15 - 14
6X4-42102-G0	11 - 1		17 - 2		14 - 8		9 - 4		9 - 10		16 - 12
6X4-42102-H0	6 - 1	65W-42527-00	16 - 3		15 - 7		9 - 7		10 - 10		19 - 9
6X4-42102-J0	6 - 1	6AH-42527-00	15 - 15		16 - 8		10 - 4		11 - 12	90185-12M12	1 - 56
6X4-42103-0C	4 - 1	6C5-42527-00	13 - 2		19 - 15		10 - 7	6X4-82586-20	7 - 13		4 - 63
6X4-42103-58	1 - 1	6FM-42527-00	19 - 2	6X4-44100-01	1 - 21		11 - 7	6X4-83383-00	2 - 10	90201-08065	15 - 17
6X4-42103-66	1 - 1	67C-42527-03	14 - 2		4 - 21		11 - 10		3 - 10	90201-08M01	12 - 3
6X4-42111-02-4D	4 - 2	63D-42528-00	12 - 16	6X4-44102-00	1 - 23	6X4-48538-00	1 - 33		5 - 11		17 - 5
6X4-42111-02-8D	1 - 2		17 - 9		4 - 23		4 - 34	6X4-83386-00	2 - 11	90201-106M5	13 - 18
6X4-42115-00	1 - 22	65W-42528-00	13 - 10	6X4-44114-00	3 - 15	6X4-48538-10	1 - 36		3 - 11		14 - 18
	4 - 22		14 - 10	6X4-44132-00	1 - 25		4 - 41		5 - 12		15 - 19
6X4-42119-01	1 - 5		15 - 8	6X4-44139-01	4 - 25	6X4-81860-00	6 - 12	6K3-83557-00	7 - 16		19 - 13
	4 - 5		16 - 10		1 - 9		7 - 14	6H4-83589-00	3 - 18	90201-10M76	12 - 10
6EK-42121-00	6 - 4		19 - 12		4 - 9		8 - 11	6X4-83653-00	7 - 23	90201-12035	1 - 53
	11 - 4	663-42528-00	18 - 3	6X4-44159-00-4D	4 - 47		9 - 11	6X4-83653-20	3 - 13		4 - 60
6X4-42121-00-8D	7 - 3	63D-42541-00	17 - 4	6X4-44159-00-8D	1 - 40		10 - 11	6C5-84301-00	3 - 14	90202-10M56	13 - 9
65W-42121-11-4D	4 - 55	67G-42541-00	12 - 4	6X4-44173-00	1 - 41		11 - 14	6X4-85415-00	3 - 19		14 - 9
63D-42121-22-8D	1 - 48	67G-42541-10	12 - 7		4 - 48	6X4-81942-01	2 - 13	90101-08022	15 - 16		15 - 5
63D-42126-00	1 - 17	63D-42546-00	17 - 3	6X4-44177-00	1 - 12		3 - 20	90101-12014	1 - 49		16 - 9
	4 - 17	67G-42546-00	12 - 5		4 - 12		5 - 14		4 - 56		19 - 11
6X4-42128-00	1 - 13	63D-42561-00	17 - 12	6X4-44188-00	1 - 15	62Y-82361-00	5 - 16	90109-05M89	16 - 14	90206-12M22	1 - 51

NUMERICAL INDEX

PART NO.	REF. NO.	PART NO.	REF. NO.	PART NO.	REF. NO.	PART NO.	REF. NO.	PART NO.	REF. NO.	PART NO.	REF. NO.
90206-12M22	4 - 58	90468-10005	6 - 6	97095-06014	5 - 13						
90209-10M26	13 - 11		7 - 8	97095-06035	5 - 18						
	14 - 11		7 - 11	97095-08050	17 - 6						
	15 - 13		8 - 5	97595-05520	19 - 6						
	16 - 11		8 - 8	97595-06516	7 - 20						
90386-08032	1 - 16		9 - 5		17 - 14						
	4 - 16		9 - 8		17 - 21						
90386-12003	1 - 54		10 - 5	97595-06530	1 - 32						
	4 - 61		10 - 8		4 - 32						
90386-26MA3	1 - 44		11 - 6	97595-06535	17 - 17						
	4 - 51		11 - 9	97595-08025	12 - 12						
90387-05053	13 - 12	90501-23215	1 - 14	97595-08540	1 - 31						
	14 - 12		4 - 14		4 - 31						
	15 - 9	91490-20010	1 - 11	97780-60620	3 - 16						
	19 - 8		1 - 20	97780-60920	1 - 42						
90387-05054	13 - 14		4 - 11		4 - 49						
	14 - 14		4 - 20	97980-06216	2 - 9						
	15 - 10	92990-06100	13 - 5		3 - 9						
	16 - 13		14 - 5		5 - 9						
	19 - 7		16 - 5	97985-06216	1 - 46						
90387-06M26	5 - 20	92990-08600	17 - 7		4 - 53						
	17 - 18		18 - 7								
90387-12M02	1 - 52	92990-12200	1 - 50								
	4 - 59		4 - 57								
90447-22006	5 - 21	92990-12600	1 - 55								
90447-22007	7 - 15		4 - 62								
90464-08M07	2 - 4	92995-05600	13 - 16								
	3 - 4		14 - 16								
	5 - 4		15 - 12								
90464-09M42	4 - 36	92995-06600	5 - 19								
	6 - 9	92995-08200	19 - 14								
	7 - 12	93700-06M03	1 - 3								
	8 - 9		4 - 3								
	9 - 9		16 - 2								
	10 - 9	95380-05600	13 - 17								
	11 - 11		14 - 17								
90465-13M24	5 - 22	95380-06600	1 - 19								
	6 - 11		4 - 19								
	7 - 21	97080-06035	18 - 4								
	11 - 13	97095-05020	13 - 15								
90465-13M30	7 - 22		14 - 15								
90465-13M36	5 - 15		15 - 11								
	8 - 12	97095-06014	1 - 35								
	9 - 12		1 - 38								
	17 - 19		2 - 12								
90465-13M39	10 - 12		3 - 12								
90468-10005	4 - 39		4 - 37								
	4 - 45		4 - 43								