



PARTS CATALOGUE

RIGGING-STEERING



1Q601-10SEA

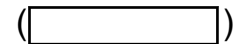

RIGGING-STEERING
PARTS CATALOGUE

©2016 by Yamaha Motor Co., Ltd.
1st edition, October 2016

All rights reserved.

Any reprinting or unauthorized use
without the written permission of
Yamaha Motor Co., Ltd.
is expressly prohibited.

Printed in Japan.

FOREWORD

This Parts Catalogue is related to the parts for the model(s) on the cover page. When you are ordering replacement parts, please refer to this Parts Catalogue and quote both part numbers and part names correctly.

1. Modifications or additions which have been made after the issue of the Parts Catalogue will be announced in the Parts News.
It is advisable that you make the necessary corrections to the Parts Catalogue according to the Parts News.

2. Abbreviations

The following abbreviations are used in this Parts Catalogue.

“UR” Use specified parts number.

“UN” Use as many as needed.

“AP” Alternate Parts

“LM” Locally Made (Parts need to be ordered locally)

“F#” Frame No. (Applicable machine No.)

“O/S” Over Size

3. The number of components for assembly

- Parts, which are to be supplied in an assembly, are listed with a dot (.) in front of the part name as shown below.
- The numeral appearing to the right of each component part indicates the quantity of parts for each assembly unit.

PART NO.	DESCRIPTION	Q'TY	REMARKS
2F5-83310-60	FRONT FLASHER LIGHT ASSY	2	
115-83311-60	.BULB (6V-18W)	1	

4. Applicable colours of graphics are represented in the “REMARKS” as shown below.

PART NO.	DESCRIPTION	Q'TY	REMARKS
2N4-24110-00-X5	FUEL TANK COMP.	2	MXR
3J1-24240-10	.GRAPHIC, FUEL TANK	1	FOR MXR

5. Note that the illustrations for reference in finding parts numbers are not to be used for assembling. When assembling, please use the applicable service manual.

6. The asterisk (*) before a reference number indicates modified items after the first edition.

CONTENTS

BASE HANDLE - ALL.....	1
BASE HANDLE ELECTRICAL 1.....	4
BASE HANDLE ELECTRICAL 2.....	5
TILLER HANDLE KIT 1.....	6
TILLER HANDLE KIT 2.....	9
FITTING KIT 1.....	10
FITTING KIT 2.....	11
STEERING FRICTION 1.....	12
FITTING KIT 3.....	13
STEERING FRICTION 2.....	14
FITTING KIT 4.....	15
STEERING FRICTION 3.....	16
FITTING KIT 5.....	17
STEERING FRICTION 4.....	18
STEERING FRICTION 5.....	19
STEERING FRICTION 6.....	20
STEERING FRICTION 7.....	21
STEERING FRICTION 8.....	22
STEERING FRICTION 9.....	23
STEERING FRICTION 10.....	24

INDEX

NUMERICAL INDEX.....	25
----------------------	----

Application Model

PART NO. / PART NAME													
FIG.NO.													
FOR US													
FOR EU & ANZ													
MODEL CODE	MODEL NAME	SERIAL NO.	6X4-42103-55	6X4-42103-0A	6X4-42102-C0	6X4-42102-11	6X4-42102-23	6X4-42102-71	6X4-42103-65	6X4-42102-A1	6X4-42102-91	6X4-42102-81	6X4-42102-B1
			TILLER HANDLE KIT	TILLER HANDLE KIT	FITTING KIT	FITTING KIT	FITTING KIT	FITTING KIT	TILLER HANDLE KIT	FITTING KIT	FITTING KIT	FITTING KIT	FITTING KIT
			FIG.1, 2	FIG.4, 5, 15	FIG.6, 8	FIG.7, 8	FIG.9, 10	FIG.11, 12	FIG.1, 3	FIG.7, 8	FIG.9, 10	FIG.11, 12	FIG.13, 8
6BP9	F25A-2016 F25B-2016	6BPK-1036107-		*									
6EK3	F115B F115B-2016	6EK-1028131-	*		*				*				
6FN2	VF115A-2016	6FN-1002231-	*		*								
6EM2	F130A F130A-2016	6EM-1001767-	*		*				*				
6D6D	F75A-2016	62P-1015521-	*			*			*	*			
6D8D	F90A-2016	61P-1082949-	*			*			*	*			
6C1D	F50H F50B-2016	6C1-1065567-	*				*		*		*		
6C5D	F60F F60B-2016	6C5-1072151-	*					*	*		*		
6C2D	FT50J T50B-2016	6C2-1022163-	*					*	*		*		
6C6D	FT60G T60B-2016	6C6-1027348-	*					*	*		*		
6CJ7	F70A F70A-2016	6CJ-1056529-	*					*	*		*		
6BT9	F30B F30A-2016	6BT-1012897-	*						*			*	
6BG9	F40F F40A-2016	6BG-1054685-	*						*			*	
6D7D	F80B F80A-2016	6D7-1018354-							*	*			
6D9D	F100D F100A-2016	6D9-1027529-							*	*			
68VG	F115A	68V-1168776-							*				*

6X4 TILLER HANDLE KIT (F30A,F30B-F130A)

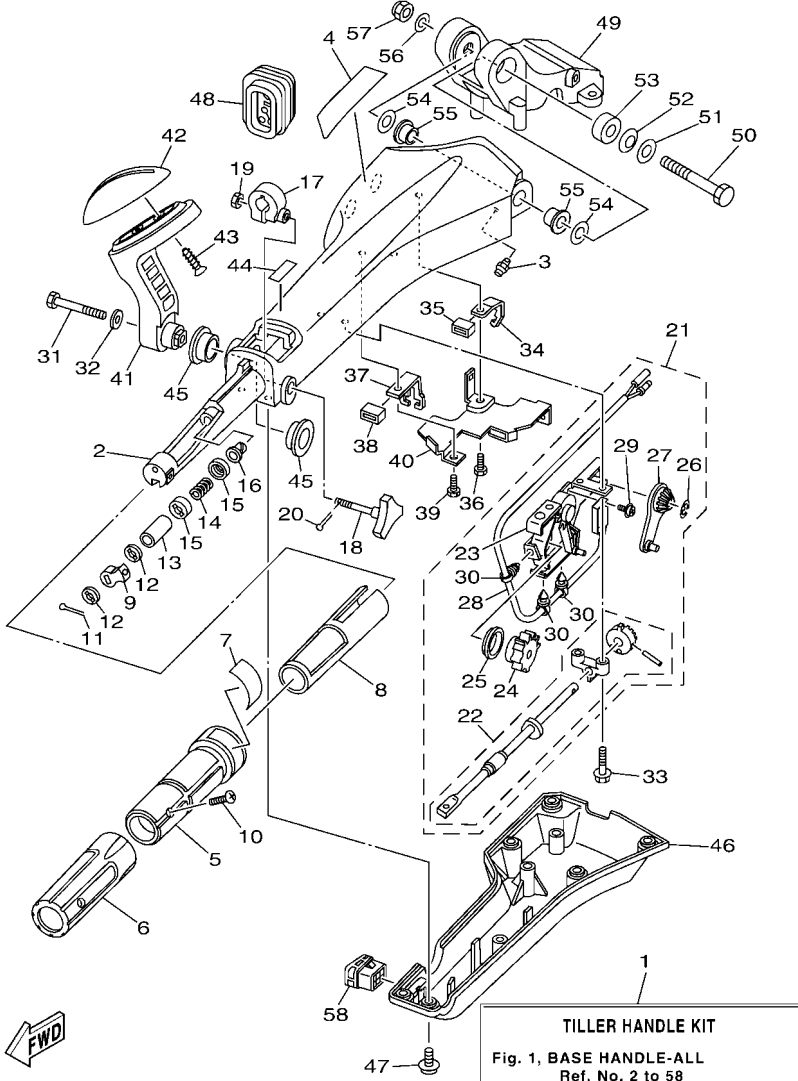

601S10S-Q010

FIG. 1 BASE HANDLE - ALL

REF. NO.	PART NO.	DESCRIPTION	601S				REMARKS
1	6X4-42103-55	TILLER HANDLE KIT	1				LM FOR US
	6X4-42103-65	TILLER HANDLE KIT	1				LM FOR EU & ANZ
2	6X4-42111-02-8D	HANDLE, STEERING	1				
3	93700-06M03	NIPPLE, GREASE	1				
4	6X4-48215-00	GRAPHIC	1				
5	6X4-42119-01	GRIP, STEERING HANDLE	1				
6	6X4-42177-00	RUBBER, HANDLE	1				
7	6X4-42137-00	INDICATOR, THROTTLE	1				
8	6X4-41291-00	BUSHING	1				
9	6X4-44139-01	COLLAR	1				
10	90152-05007	SCREW, COUNTERSUNK	1				
11	91490-20010	PIN. COTTER	1				
12	6X4-44177-00	WASHER	2				
13	6X4-42128-00	COLLAR, DISTANCE 1	1				
14	90501-23215	SPRING, COMPRESSION	1				
15	6X4-44188-00	WASHER	2				
16	90386-08032	BUSH	1				
17	63D-42126-00	FRICTION, STEERING HANDLE GRIP	1				
18	6X4-48154-00	KNOB, THROTTLE	1				
19	95380-06600	NUT, HEXAGON	1				
20	91490-20010	PIN. COTTER	1				
21	6X4-44100-01	SHIFT LINK ASSY	1				
22	6X4-42115-00	.SHAFT, STEERING HANDLE	1				
23	6X4-44102-00	.SHIFT ASSIST ASSY.	1				
24	6X4-47731-01	.GEAR, DRIVE	1				
25	6X4-44132-00	.BUSHING	1				
26	6X4-14137-00	.CLIP	1				

6X4 TILLER HANDLE KIT (F30A,F30B-F130A)

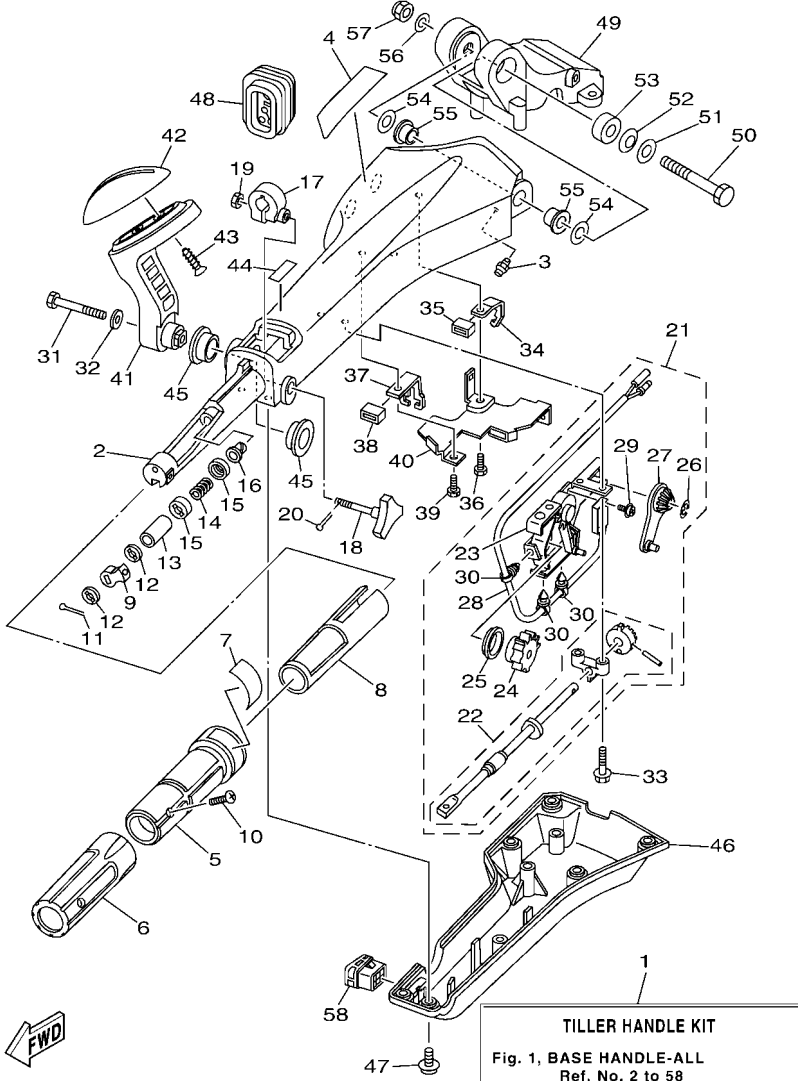

601S10S-Q010

FIG. 1 BASE HANDLE - ALL

REF. NO.	PART NO.	DESCRIPTION	QTY	REMARKS
27	6X4-48261-00	.ARM, THROTTLE	1	
28	6X4-82540-00	.NEUTRAL SWITCH ASSY	1	
29	703-48129-00	.SCREW 3	2	
30	6X4-42821-00	.BAND, CLAMP	3	
31	97095-08040	BOLT	1	
32	92995-08600	WASHER	1	
33	97595-06530	BOLT, WITH WASHER	1	
34	6X4-48538-00	CLAMP, CABLE 1	1	
35	6X4-26367-00	PROTECTOR	1	
36	97095-06014	BOLT	1	
37	6X4-48538-10	CLAMP, CABLE 1	1	
38	6X4-26367-00	PROTECTOR	1	
39	97095-06014	BOLT	1	
40	6X4-42159-00	STAY	1	
41	6X4-44159-00-8D	HANDLE, GEAR SHIFT	1	
42	6X4-44173-00	LEVER, SHIFT CONTROL	1	
43	97780-60920	SCREW, TAPPING	2	
44	6G8-44191-00	INDICATOR, SHIFT	1	
45	90386-26MA3	BUSH	2	
46	6X4-42131-01	COVER, HANDLE STEERING	1	FOR US
	6X4-42131-11	COVER, HANDLE STEERING	1	FOR EU & ANZ
47	97985-06216	SCREW, WITH WASHER	6	
48	6X4-42725-01	GROMMET	1	
49	63D-42121-22-8D	BRACKET	1	
50	90101-12014	BOLT	1	
51	92990-12200	WASHER, PLAIN	1	
52	90206-12M22	WASHER, WAVE	1	

6X4 TILLER HANDLE KIT (F30A,F30B-F130A)

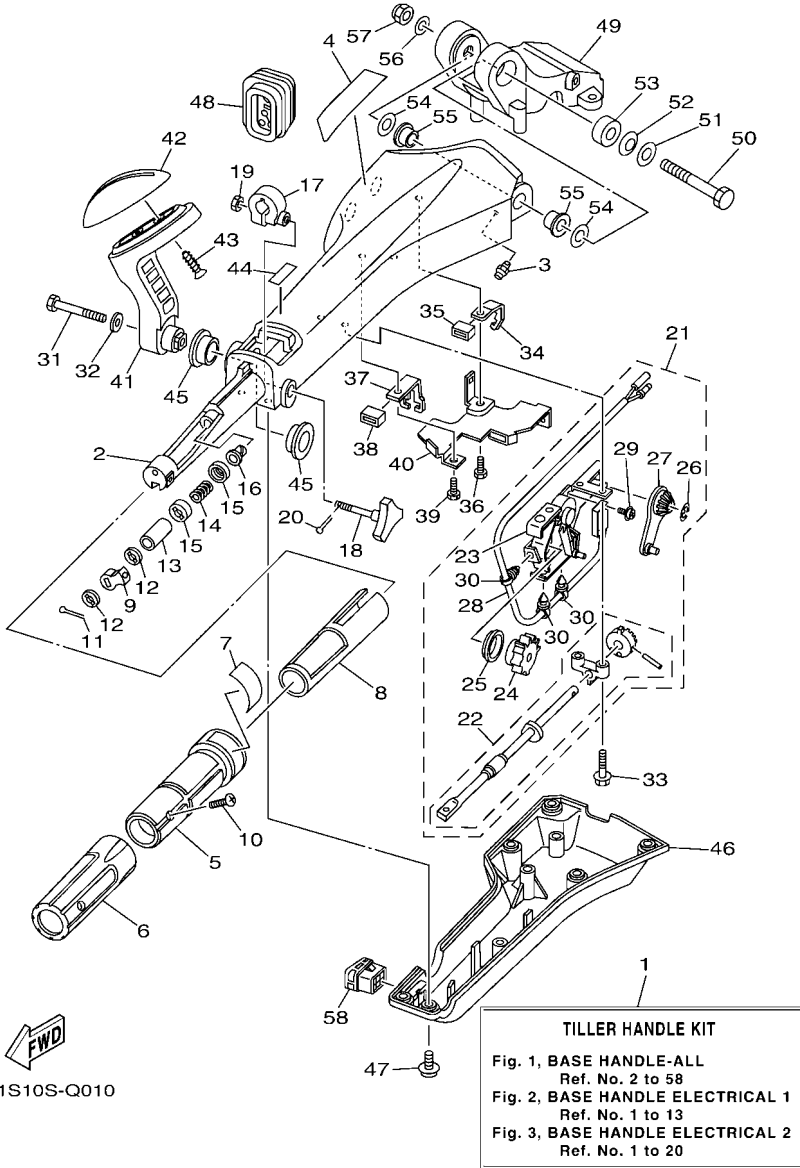

601S10S-Q010

FIG. 1 BASE HANDLE - ALL

REF. NO.	PART NO.	DESCRIPTION	601S				REMARKS
53	90387-12M02	COLLAR	1				
54	90201-12035	WASHER, PLATE	2				
55	90386-12003	BUSH	2				
56	92990-12600	WASHER, PLATE	1				
57	90185-12M12	NUT, SELF-LOCKING	1				
58	6X4-42728-10	CAP	1				

6X4 TILLER HANDLE KIT (F30A-F130A FOR US)

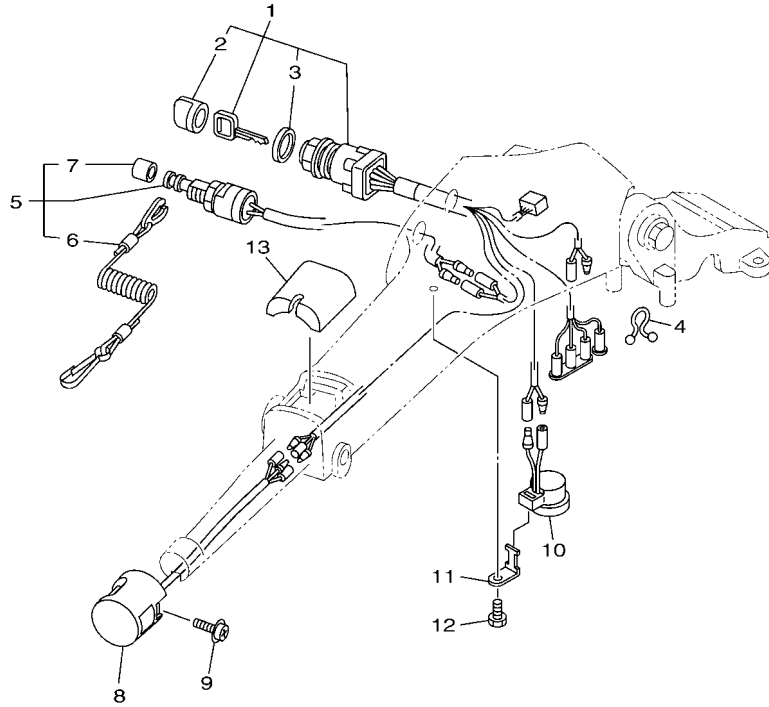

FIG. 2 BASE HANDLE ELECTRICAL 1

REF. NO.	PART NO.	DESCRIPTION	601S				REMARKS
1	6X4-82510-01	MAIN SWITCH ASSY	1				
2	676-82577-01	.CAP, KEY	1				
3	703-82532-00	.CAP	1				
4	90464-08M07	CLAMP	1				
5	69W-82575-00	ENGINE STOP SWITCH ASSY	1				
6	682-82556-00	.LANYARD, STOP SWITCH	1				
7	689-8257Y-00	.CAP	1				
8	6X4-82563-00	TRIM & TILT SWITCH ASSY	1				
9	97980-06216	SCREW, WITH WASHER	1				
10	6X4-83383-00	BUZZER	1				
11	6X4-83386-00	STAY, BUZZER	1				
12	97095-06014	BOLT	1				
13	6X4-81942-01	COVER	1				



601S10S-Q020

6X4 TILLER HANDLE KIT (F30B-F130A FOR EU&ANZ)

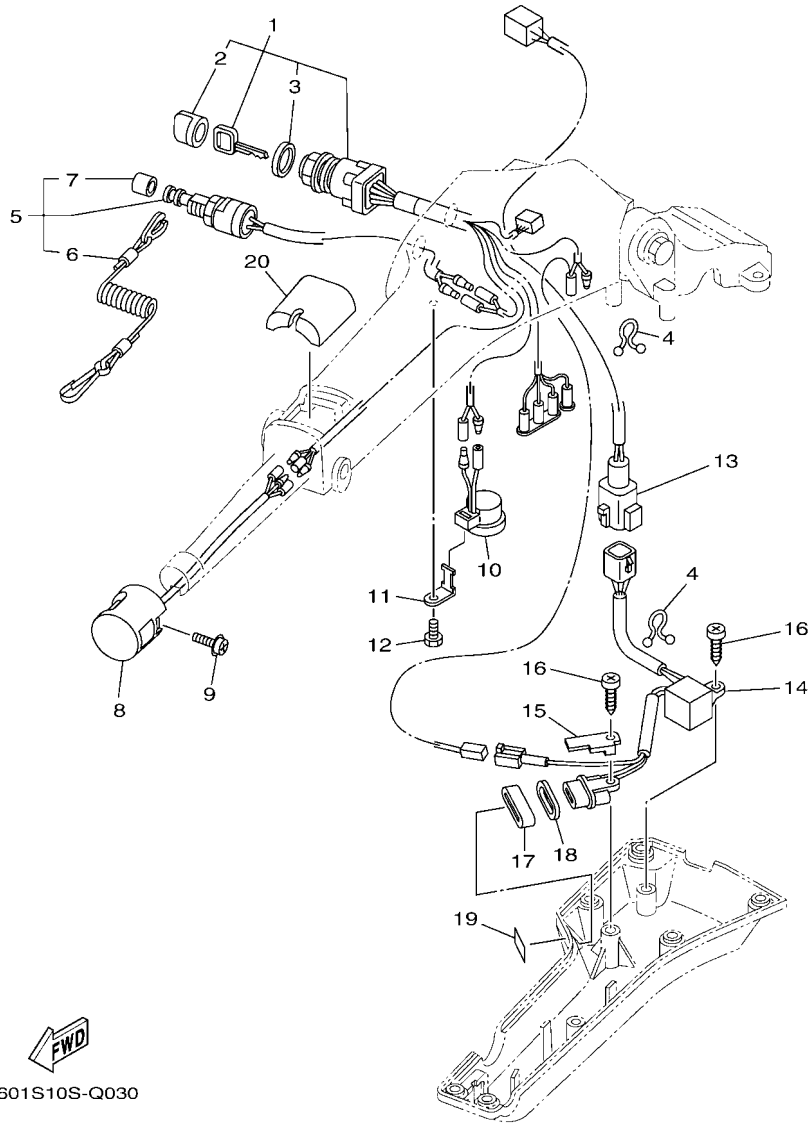

601S10S-Q030

FIG. 3 BASE HANDLE ELECTRICAL 2

REF. NO.	PART NO.	DESCRIPTION	601S				REMARKS
1	6X4-82510-41	MAIN SWITCH ASSY	1				
2	676-82577-01	.CAP, KEY	1				
3	703-82532-00	.CAP	1				
4	90464-08M07	CLAMP	2				
5	69W-82575-00	ENGINE STOP SWITCH ASSY	1				
6	682-82556-00	.LANYARD, STOP SWITCH	1				
7	689-8257Y-00	.CAP	1				
8	6X4-82563-01	TRIM & TILT SWITCH ASSY	1				
9	97980-06216	SCREW, WITH WASHER	1				
10	6X4-83383-00	BUZZER	1				
11	6X4-83386-00	STAY, BUZZER	1				
12	97095-06014	BOLT	1				
13	6X4-83653-20	WIRE, LEAD (L:700MM)	1				
14	6C5-84301-00	PILOT LIGHT ASSY 1	1				
15	6X4-44114-00	STOPPER	1				
16	97780-60620	SCREW, TAPPING	2				
17	6X4-42727-00	GROMMET	1				
18	6H4-83589-00	GASKET	1				
19	6X4-85415-00	MARK, SIGNAL LAMP	1				
20	6X4-81942-01	COVER	1				

6X4 TILLER HANDLE KIT (F25A,F25B)

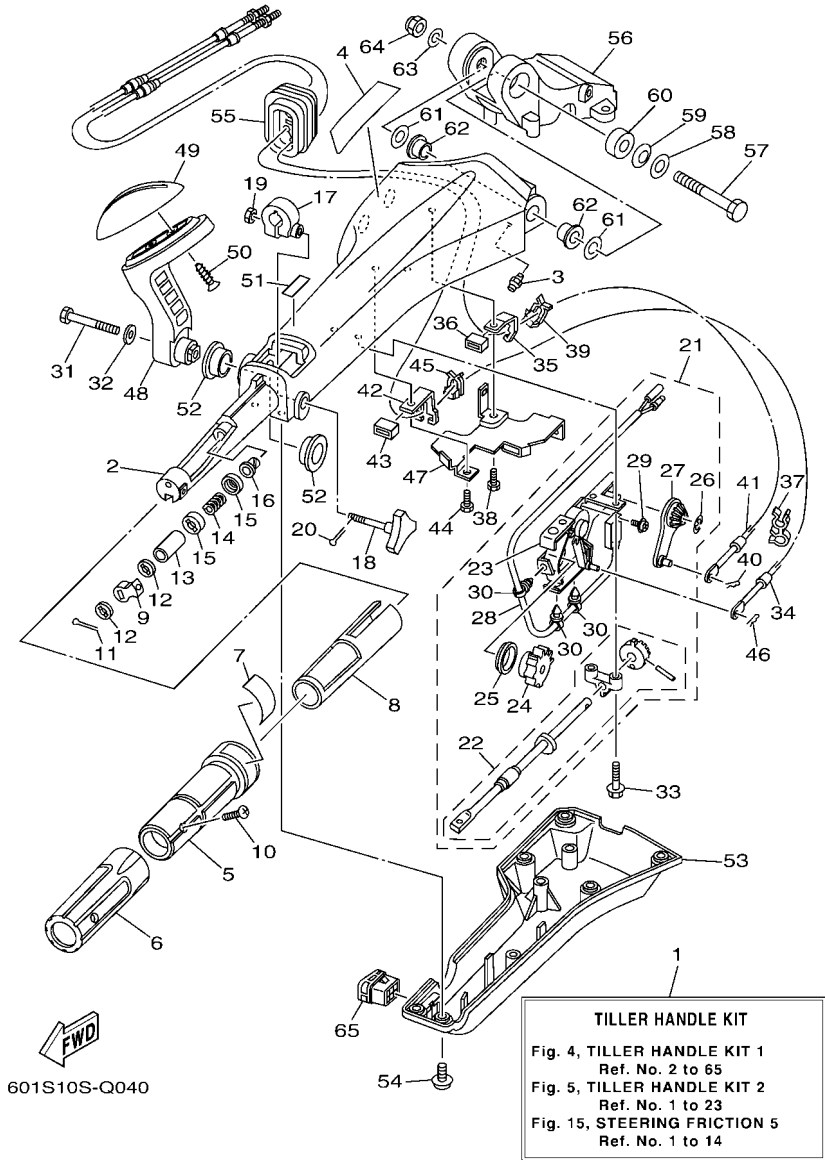

FIG. 4 TILLER HANDLE KIT 1

REF. NO.	PART NO.	DESCRIPTION	601S				REMARKS
1	6X4-42103-0A	TILLER HANDLE KIT	1				LM
2	6X4-42111-02-4D	HANDLE, STEERING	1				
3	93700-06M03	NIPPLE, GREASE	1				
4	6X4-48215-00	GRAPHIC	1				
5	6X4-42119-01	GRIP, STEERING HANDLE	1				
6	6X4-42177-00	RUBBER, HANDLE	1				
7	6X4-42137-00	INDICATOR, THROTTLE	1				
8	6X4-41291-00	BUSHING	1				
9	6X4-44139-01	COLLAR	1				
10	90152-05007	SCREW, COUNTERSUNK	1				
11	91490-20010	PIN, COTTER	1				
12	6X4-44177-00	WASHER	2				
13	6X4-42128-00	COLLAR, DISTANCE 1	1				
14	90501-23215	SPRING, COMPRESSION	1				
15	6X4-44188-00	WASHER	2				
16	90386-08032	BUSH	1				
17	63D-42126-00	FRICTION, STEERING HANDLE GRIP	1				
18	6X4-48154-00	KNOB, THROTTLE	1				
19	95380-06600	NUT, HEXAGON	1				
20	91490-20010	PIN, COTTER	1				
21	6X4-44100-01	SHIFT LINK ASSY	1				
22	6X4-42115-00	.SHAFT, STEERING HANDLE	1				
23	6X4-44102-00	.SHIFT ASSIST ASSY.	1				
24	6X4-47731-01	.GEAR, DRIVE	1				
25	6X4-44132-00	.BUSHING	1				
26	6X4-14137-00	.CLIP	1				
27	6X4-48261-00	.ARM, THROTTLE	1				

6X4 TILLER HANDLE KIT (F25A,F25B)

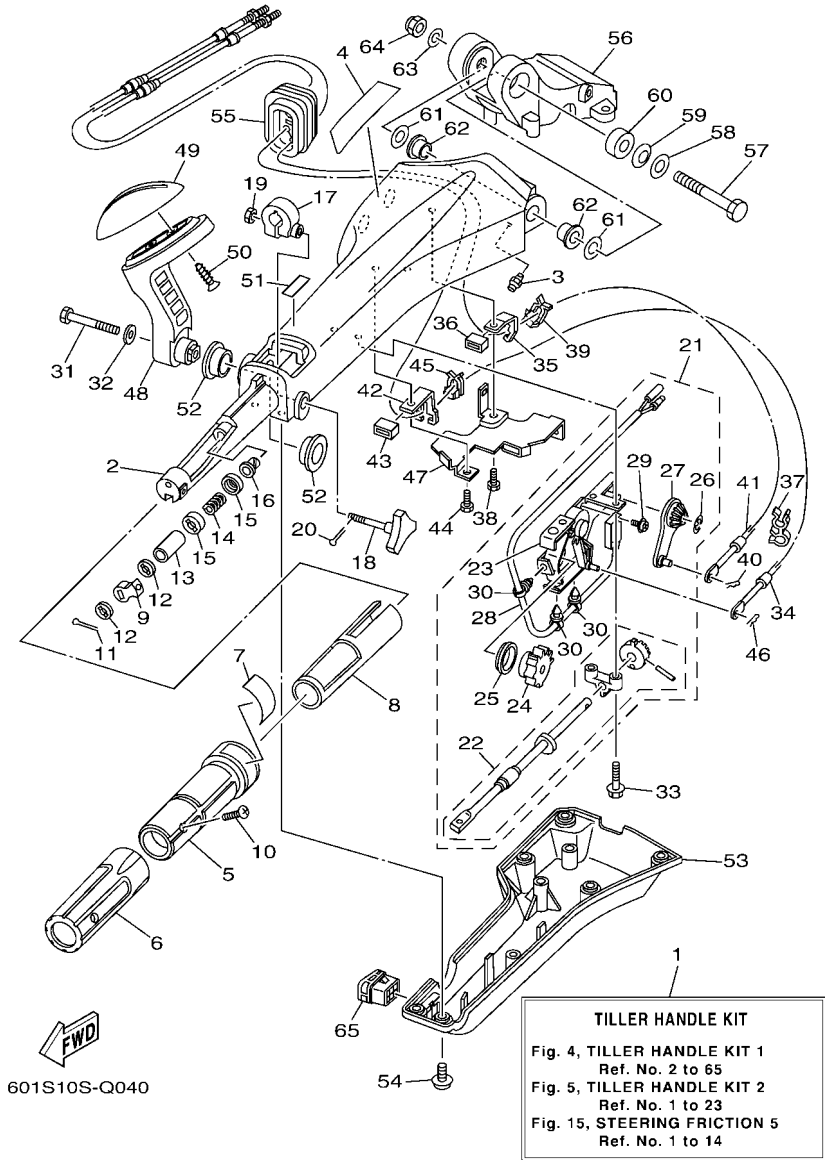

FIG. 4 TILLER HANDLE KIT 1

REF. NO.	PART NO.	DESCRIPTION	601S				REMARKS
28	6X4-82540-00	.NEUTRAL SWITCH ASSY	1				
29	703-48129-00	.SCREW 3	2				
30	6X4-42821-00	.BAND, CLAMP	3				
31	97095-08040	BOLT	1				
32	92995-08600	WASHER	1				
33	97595-06530	BOLT, WITH WASHER	1				
34	6H1-48321-21	CABLE	1				
35	6X4-48538-00	CLAMP, CABLE 1	1				
36	6X4-26367-00	PROTECTOR	1				
37	90464-09M42	CLAMP	1				
38	97095-06014	BOLT	1				
39	63D-48538-00	CLAMP, CABLE 1	1				
40	90468-10005	CLIP	1				
41	6H3-48321-02	CABLE	1				
42	6X4-48538-10	CLAMP, CABLE 1	1				
43	6X4-26367-00	PROTECTOR	1				
44	97095-06014	BOLT	1				
45	63D-48538-00	CLAMP, CABLE 1	1				
46	90468-10005	CLIP	1				
47	6X4-42159-00	STAY	1				
48	6X4-44159-00-4D	HANDLE, GEAR SHIFT	1				
49	6X4-44173-00	LEVER, SHIFT CONTROL	1				
50	97780-60920	SCREW, TAPPING	2				
51	6G8-44191-00	INDICATOR, SHIFT	1				
52	90386-26MA3	BUSH	2				
53	6X4-42131-01	COVER, HANDLE STEERING	1				
54	97985-06216	SCREW, WITH WASHER	6				

6X4 TILLER HANDLE KIT (F25A,F25B)

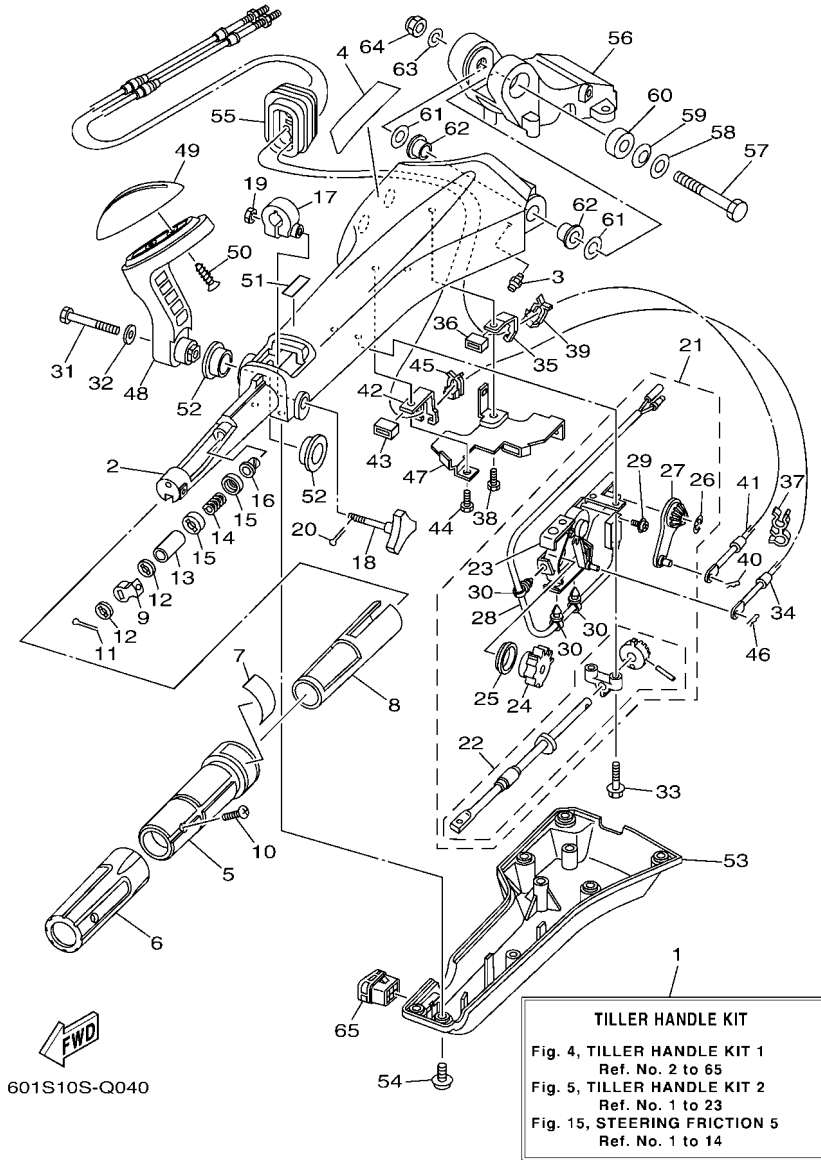
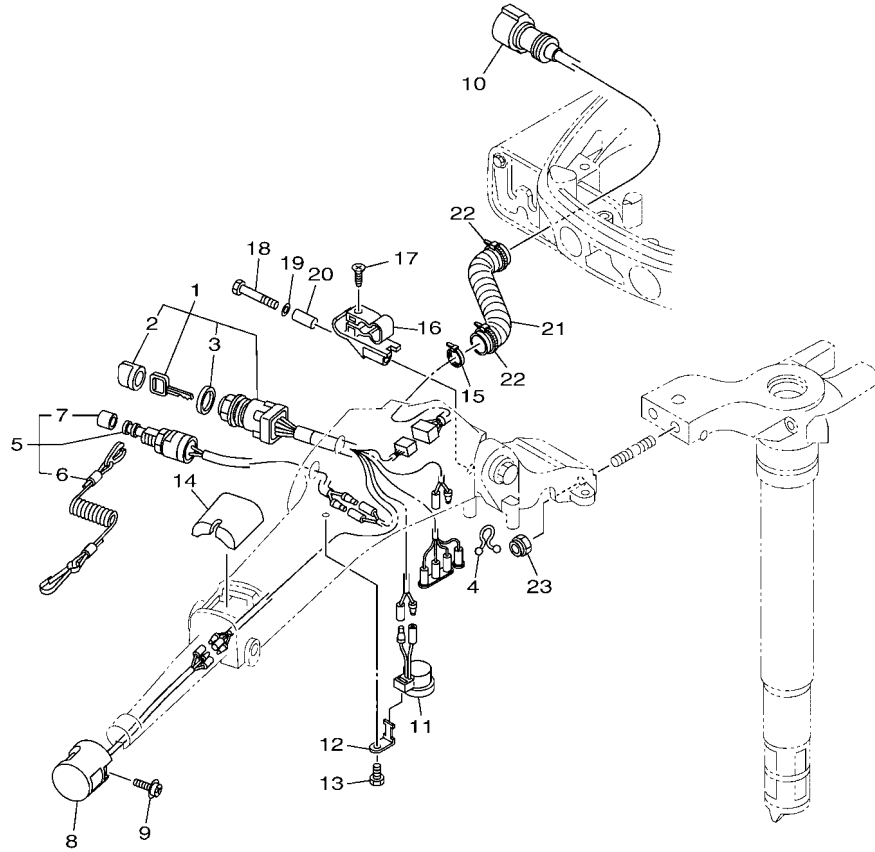

FIG. 4 TILLER HANDLE KIT 1

REF. NO.	PART NO.	DESCRIPTION	QTY	REMARKS
55	6X4-42725-01	GROMMET	1	
56	65W-42121-11-4D	BRACKET	1	
57	90101-12014	BOLT	1	
58	92990-12200	WASHER, PLAIN	1	
59	90206-12M22	WASHER, WAVE	1	
60	90387-12M02	COLLAR	1	
61	90201-12035	WASHER, PLATE	2	
62	90386-12003	BUSH	2	
63	92990-12600	WASHER, PLATE	1	
64	90185-12M12	NUT, SELF-LOCKING	1	
65	6X4-42728-10	CAP	1	

6X4 TILLER HANDLE KIT (F25A,F25B)



601S10S-Q050

FIG. 5 TILLER HANDLE KIT 2

REF. NO.	PART NO.	DESCRIPTION	601S				REMARKS
1	6X4-82510-01	MAIN SWITCH ASSY	1				
2	676-82577-01	.CAP, KEY	1				
3	703-82532-00	.CAP	1				
4	90464-08M07	CLAMP	1				
5	69W-82575-00	ENGINE STOP SWITCH ASSY	1				
6	682-82556-00	.LANYARD, STOP SWITCH	1				
7	689-8257Y-00	.CAP	1				
8	6X4-82563-00	TRIM & TILT SWITCH ASSY	1				
9	97980-06216	SCREW, WITH WASHER	1				
10	6X4-82586-10	EXT., WIRE HARNESS (L:950MM)	1				
11	6X4-83383-00	BUZZER	1				
12	6X4-83386-00	STAY, BUZZER	1				
13	97095-06014	BOLT	1				
14	6X4-81942-01	COVER	1				
15	90465-13M36	CLAMP	1				
16	62Y-82361-00	CLAMP, CORD	1				
17	90161-06M03	SCREW, TAPPING	1				
18	97095-06035	BOLT	1				
19	92995-06600	WASHER	1				
20	90387-06M26	COLLAR	1				
21	90447-22006	TUBE	1				
22	90465-13M24	CLAMP	2				
23	90185-10027	NUT, SELF-LOCKING	2				

6X4 TILLER HANDLE FITTING KIT (F115B,VF115A,F130A)

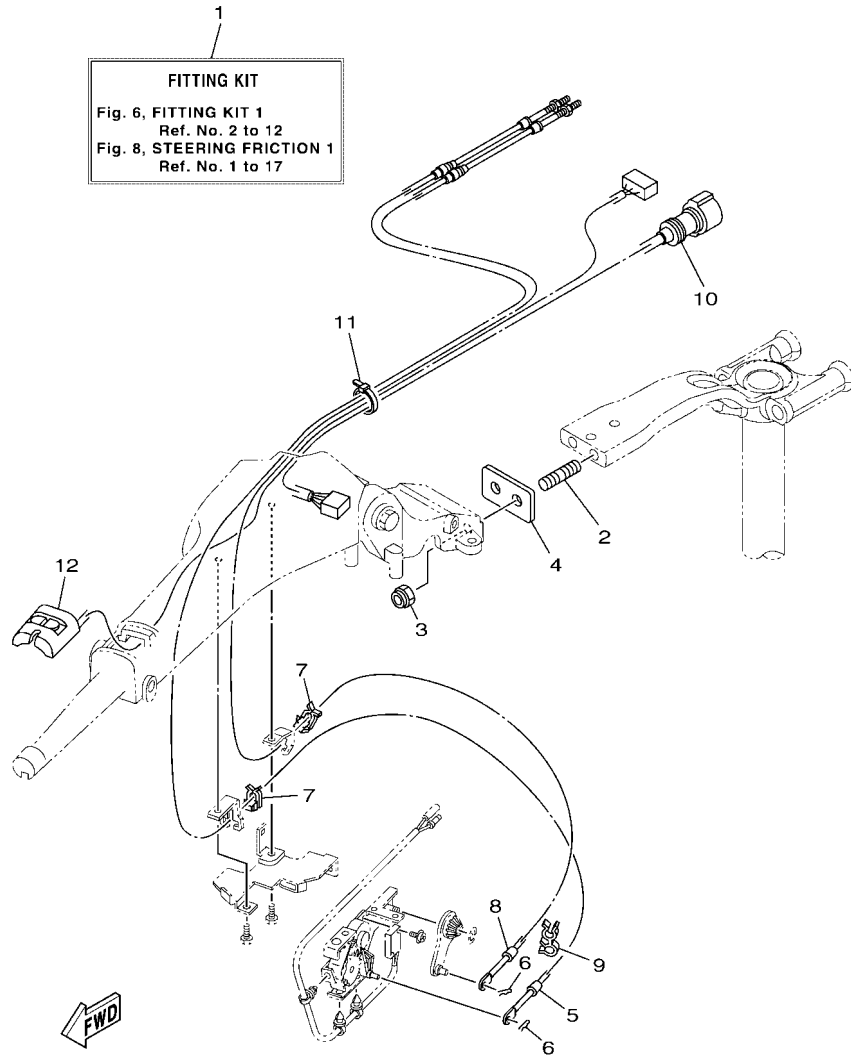

601S10S-Q060

FIG. 6 FITTING KIT 1

REF. NO.	PART NO.	DESCRIPTION	601S				REMARKS
1	6X4-42102-C0	FITTING KIT	1				LM
2	90116-10063	BOLT, STUD	2				
3	90185-10027	NUT, SELF-LOCKING	2				
4	6EK-42121-00	BRACKET	1				
5	6EK-48321-00	CABLE	1				
6	90468-10005	CLIP	2				
7	63D-48538-00	CLAMP, CABLE 1	2				
8	6EK-26301-00	THROTTLE CABLE ASSY	1				
9	90464-09M42	CLAMP	1				
10	6X4-82586-10	EXT., WIRE HARNESS (L:950MM)	1				
11	90465-13M24	CLAMP	1				
12	6X4-81860-00	SWITCH ASSY	1				

6X4 TILLER HANDLE FITTING KIT (F75A,F80A,F80B,
F90A,F100A,F100B)

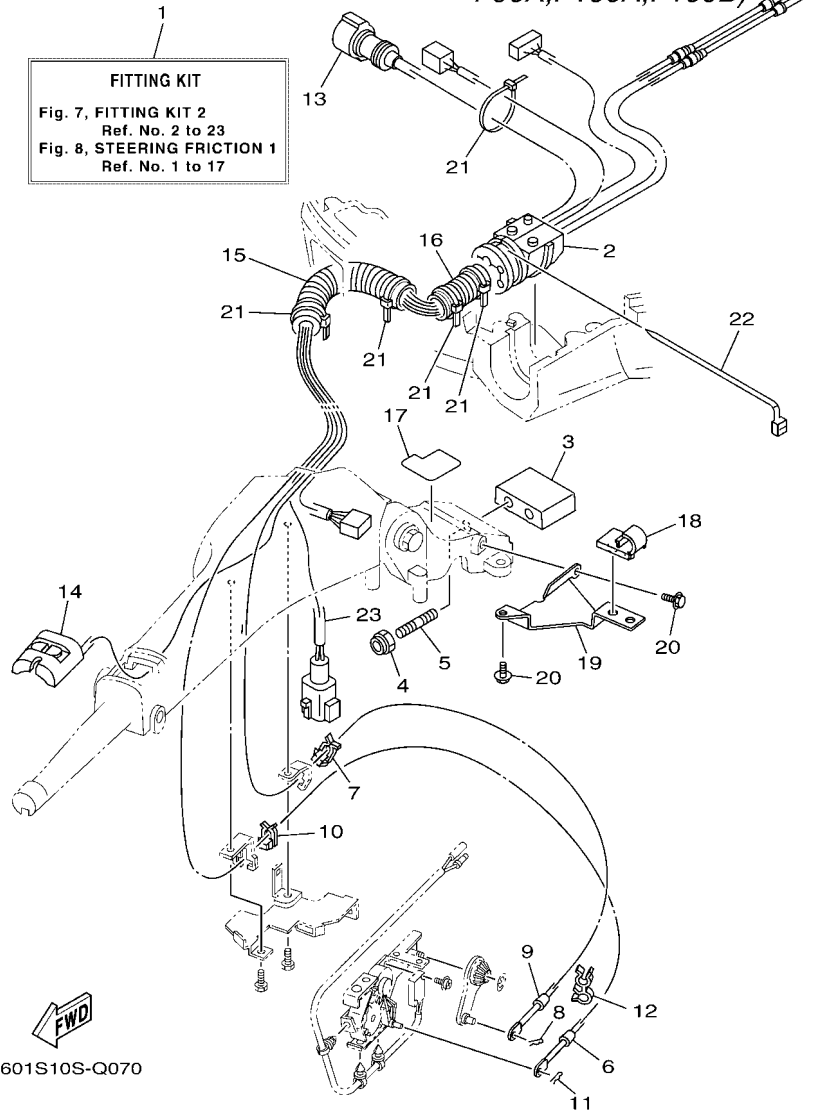
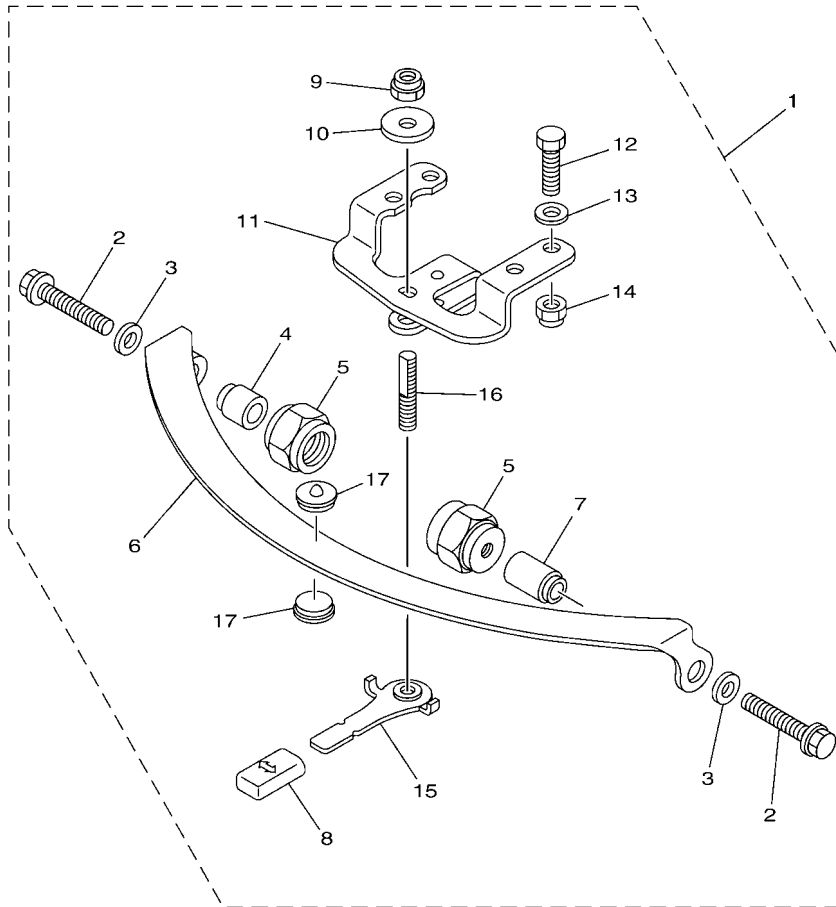

FIG. 7 FITTING KIT 2

REF. NO.	PART NO.	DESCRIPTION	601S	REMARKS
1	6X4-42102-11	FITTING KIT	1	LM FOR US
	6X4-42102-A1	FITTING KIT	1	LM FOR EU & ANZ
2	68V-42725-10	GROMMET	1	
3	6X4-42121-00-8D	BRACKET	1	
4	90185-10027	NUT, SELF-LOCKING	2	
5	90116-10031	BOLT, STUD	2	
6	67G-48321-20	CABLE	1	
7	63D-48538-00	CLAMP, CABLE 1	1	
8	90468-10005	CLIP	1	
9	67G-26301-10	THROTTLE CABLE ASSY	1	
10	63D-48538-00	CLAMP, CABLE 1	1	
11	90468-10005	CLIP	1	
12	90464-09M42	CLAMP	1	
13	6X4-82586-20	EXT., WIRE HARNESS (L:1.25M)	1	
14	6X4-81860-00	SWITCH ASSY	1	
15	90447-22007	TUBE	1	
16	6K3-83557-00	TUBE	1	
17	6X4-42735-00	PROTECTOR	1	
18	63D-24367-00	CLAMP, FUEL PIPE 2	1	
19	6X4-24364-00	STAY	1	
20	97595-06516	BOLT, WITH WASHER	2	
21	90465-13M24	CLAMP	5	
22	90465-13M30	CLAMP	1	
23	6X4-83653-00	WIRE, LEAD (L:1250MM)	1	FOR EU & ANZ

**6X4 TILLER HANDLE FITTING KIT
STEERING FRICTION (F75A,F90A,F115A,F115B,
VF115A,F130A)**



601S10S-Q080

FIG. 8 STEERING FRICTION 1

REF. NO.	PART NO.	DESCRIPTION	601S				REMARKS
1	67G-42508-10	STEERING FRICTION ASSY	1				
2	90119-08M74	.BOLT, WITH WASHER	2				
3	90201-08M01	.WASHER, PLATE	2				
4	67G-42541-00	.PIPE 1	1				
5	67G-42546-00	.NUT	2				
6	63D-42527-00	.PLATE, FRICTION	1				
7	67G-42541-10	.PIPE 1	1				
8	682-43318-01	.COVER	1				
9	90185-10M14	.NUT, SELF-LOCKING	1				
10	90201-10M76	.WASHER, PLATE	1				
11	6X4-42526-00	.PLATE, FRICTION	1				
12	97095-08025	.BOLT	2				
13	92995-08600	.WASHER	2				
14	90185-08057	.NUT, SELF-LOCKING	2				
15	67G-42561-00	.KNOB, STEERING LOCK	1				
16	67G-42562-00	.SHAFT, STEERING LOCK	1				
17	63D-42528-00	.PLATE, FRICTION	2				

6X4 TILLER HANDLE FITTING KIT
 (F50B,F50H,T50B,FT50J,F60B,F60F,T60B,FT60G,F70A)

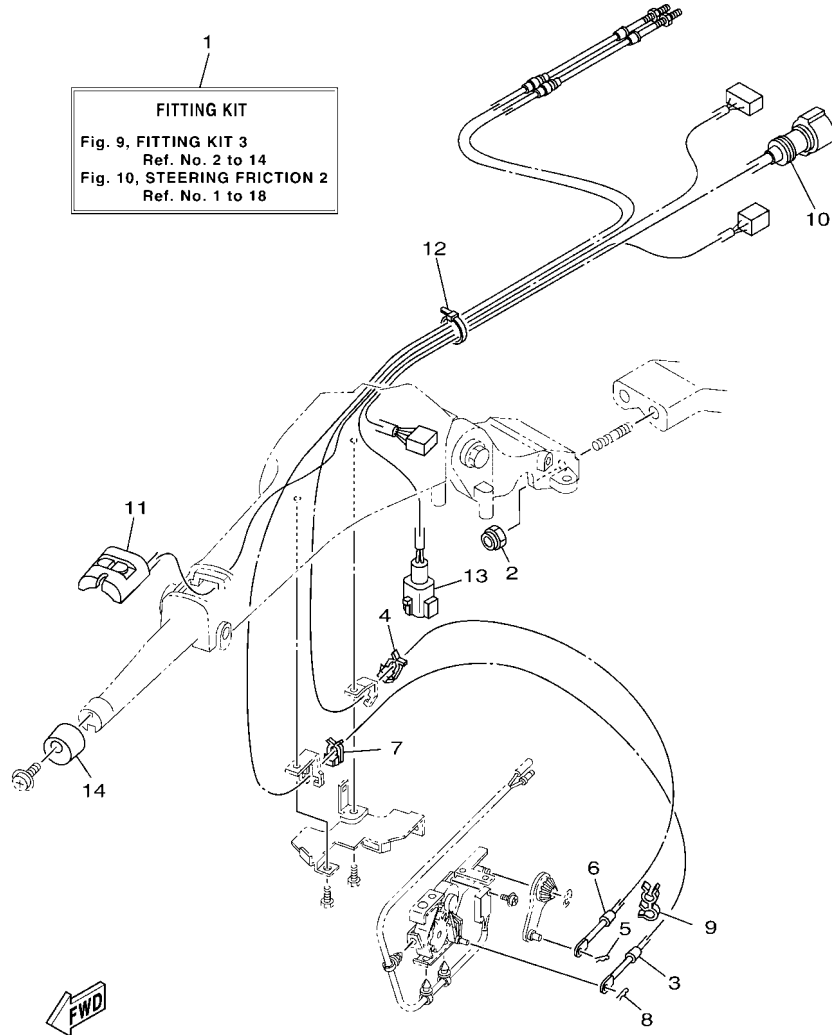

601S10S-Q090

FIG. 9 FITTING KIT 3

REF. NO.	PART NO.	DESCRIPTION	601S				REMARKS
1	6X4-42102-23	FITTING KIT	1				LM FOR US
	6X4-42102-91	FITTING KIT	1				LM FOR EU & ANZ
2	90185-10027	NUT, SELF-LOCKING	2				
3	67C-48321-11	CABLE	1				
4	63D-48538-00	CLAMP, CABLE 1	1				
5	90468-10005	CLIP	1				
6	69W-26301-00	THROTTLE CABLE ASSY	1				
7	63D-48538-00	CLAMP, CABLE 1	1				
8	90468-10005	CLIP	1				
9	90464-09M42	CLAMP	1				
10	6X4-82586-10	EXT., WIRE HARNESS (L:950MM)	1				
11	6X4-81860-00	SWITCH ASSY	1				
12	90465-13M36	CLAMP	1				
13	6X4-83653-20	.WIRE, LEAD (L:700MM)	1				FOR EU & ANZ
14	6X4-42728-00	.CAP	1				FOR EU & ANZ

6X4 TILLER HANDLE FITTING KIT
 STEERING FRICTION (F50B,F50H,T50B,FT50J,
 F60B,F60F,T60B,FT60G,F70A)

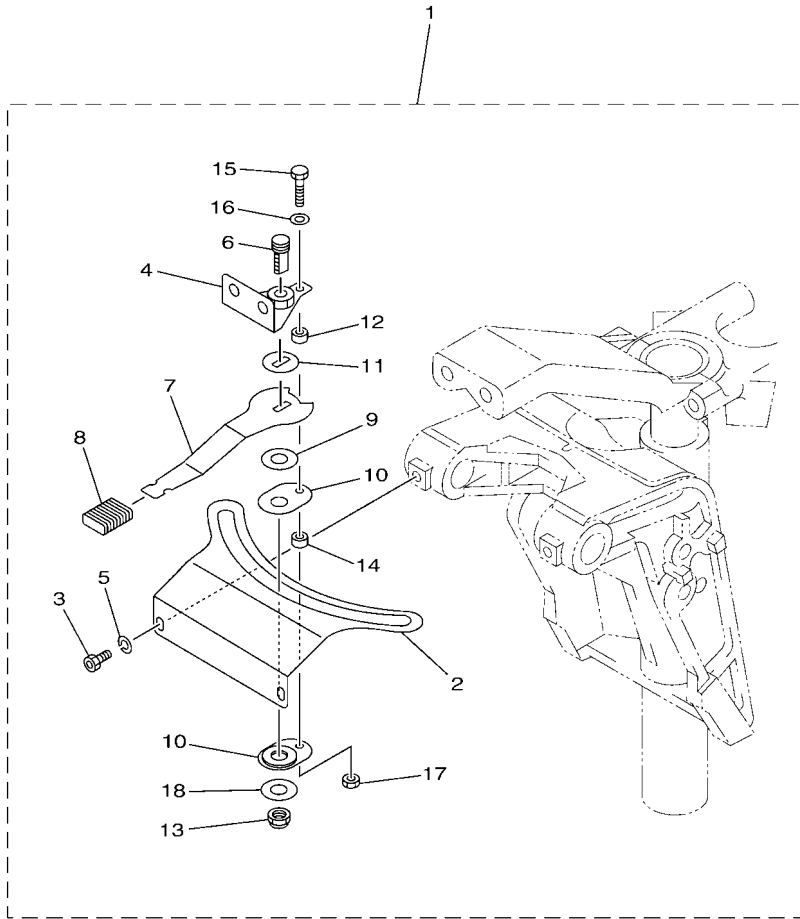



 601S10S-Q100

FIG. 10 STEERING FRICTION 2

REF. NO.	PART NO.	DESCRIPTION	601S				REMARKS
1	6C5-42508-01	STEERING FRICTION ASSY	1				
2	6C5-42527-00	.PLATE, FRICTION	1				
3	90109-06M88	.BOLT	2				
4	67C-42525-00	.PLATE, FRICTION	1				
5	92990-06100	.WASHER, SPRING	2				
6	67C-42562-00	.SHAFT, STEERING LOCK	1				
7	67C-42561-00	.KNOB, STEERING LOCK	1				
8	689-43633-00	.COVER, TILT LEVER	1				
9	90202-10M56	.WASHER, PLATE	1				
10	65W-42528-00	.PLATE, FRICTION	2				
11	90209-10M26	.WASHER	1				
12	90387-05053	.COLLAR	1				
13	90185-10M14	.NUT, SELF-LOCKING	1				
14	90387-05054	.COLLAR	1				
15	97095-05020	.BOLT	1				
16	92995-05600	.WASHER	1				
17	95380-05600	.NUT	1				
18	90201-106M5	.WASHER, PLATE	1				

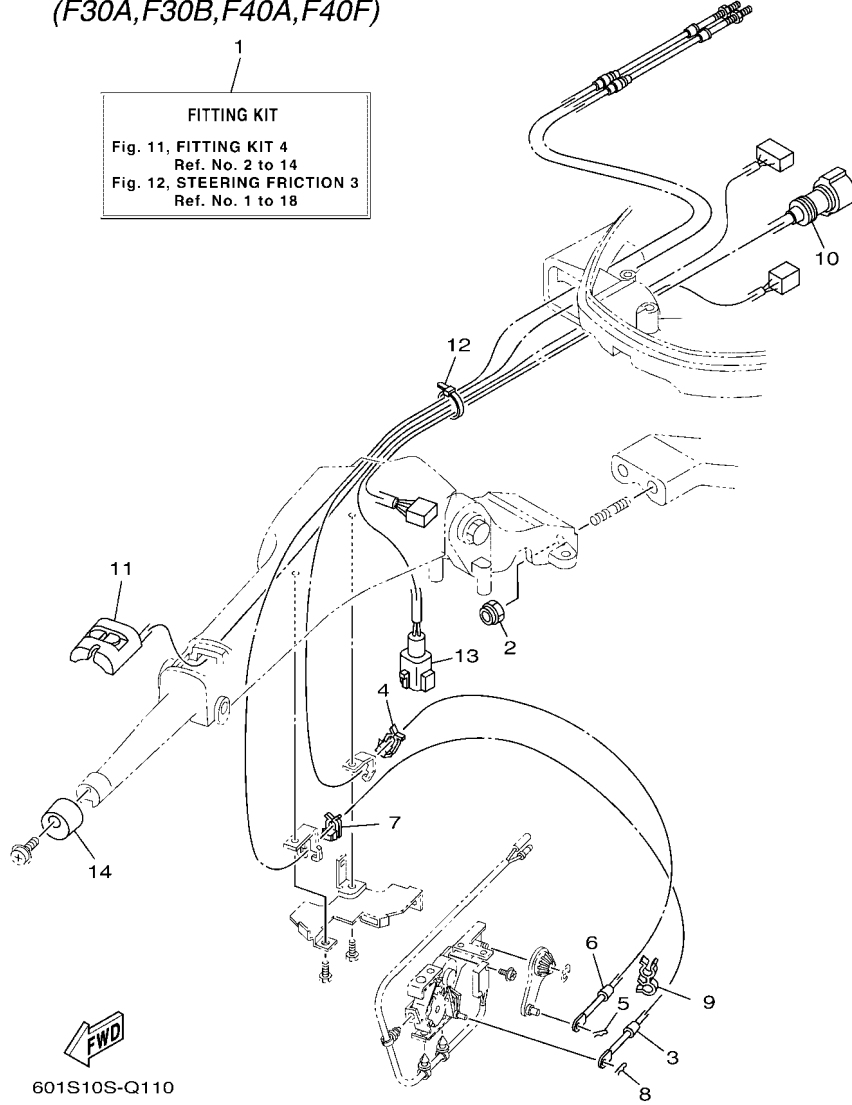
**6X4 TILLER HANDLE FITTING KIT
(F30A, F30B, F40A, F40F)**



601S10S-Q110

FIG. 11 FITTING KIT 4

REF. NO.	PART NO.	DESCRIPTION	601S				REMARKS
1	6X4-42102-71	FITTING KIT	1				LM FOR US
	6X4-42102-81	FITTING KIT	1				LM FOR EU & ANZ
2	90185-10027	NUT, SELF-LOCKING	2				
3	67C-48321-11	CABLE	1				
4	63D-48538-00	CLAMP, CABLE 1	1				
5	90468-10005	CLIP	1				
6	69W-26301-00	THROTTLE CABLE ASSY	1				
7	63D-48538-00	CLAMP, CABLE 1	1				
8	90468-10005	CLIP	1				
9	90464-09M42	CLAMP	1				
10	6X4-82586-10	EXT., WIRE HARNESS (L:950MM)	1				
11	6X4-81860-00	SWITCH ASSY	1				
12	90465-13M36	CLAMP	1				
13	6X4-83653-20	WIRE, LEAD (L:700MM)	1				FOR EU & ANZ
14	6X4-42728-00	CAP	1				FOR EU & ANZ

6X4 TILLER HANDLE FITTING KIT
STEERING FRICTION (F30A,F30B,F40A,F40F)

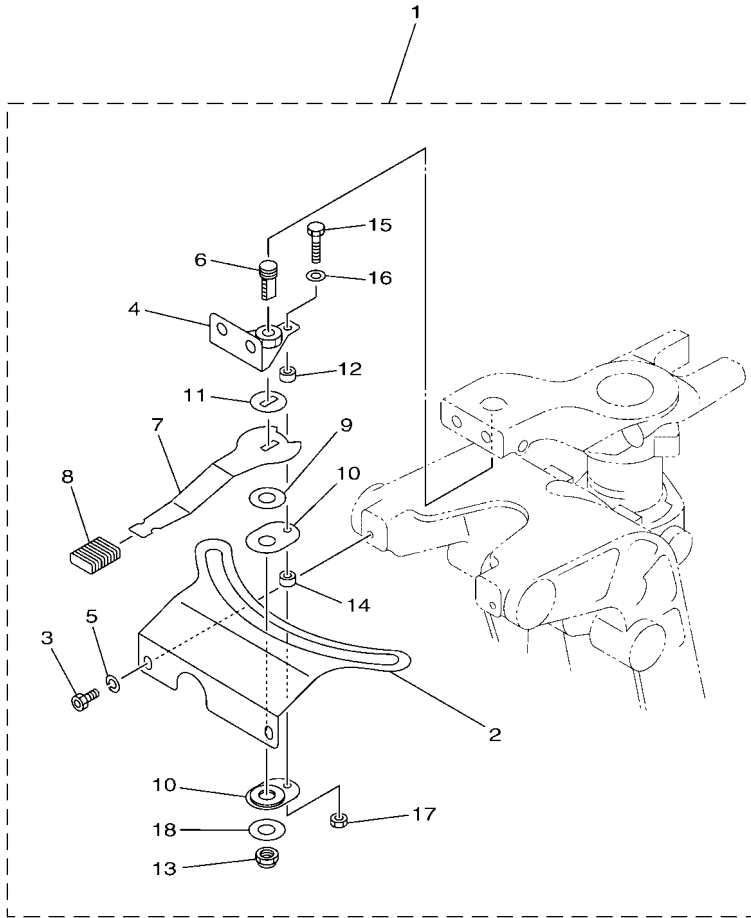

601S10S-Q120

FIG. 12 STEERING FRICTION 3

REF. NO.	PART NO.	DESCRIPTION	601S				REMARKS
1	67C-42508-04	STEERING FRICTION ASSY	1				
2	67C-42527-03	.PLATE, FRICTION	1				
3	90109-06M88	.BOLT	2				
4	67C-42525-00	.PLATE, FRICTION	1				
5	92990-06100	.WASHER, SPRING	2				
6	67C-42562-00	.SHAFT, STEERING LOCK	1				
7	67C-42561-00	.KNOB, STEERING LOCK	1				
8	689-43633-00	.COVER, TILT LEVER	1				
9	90202-10M56	.WASHER, PLATE	1				
10	65W-42528-00	.PLATE, FRICTION	2				
11	90209-10M26	.WASHER	1				
12	90387-05053	.COLLAR	1				
13	90185-10M14	.NUT, SELF-LOCKING	1				
14	90387-05054	.COLLAR	1				
15	97095-05020	.BOLT	1				
16	92995-05600	.WASHER	1				
17	95380-05600	.NUT	1				
18	90201-106M5	.WASHER, PLATE	1				

6X4 TILLER HANDLE FITTING KIT (F115A)

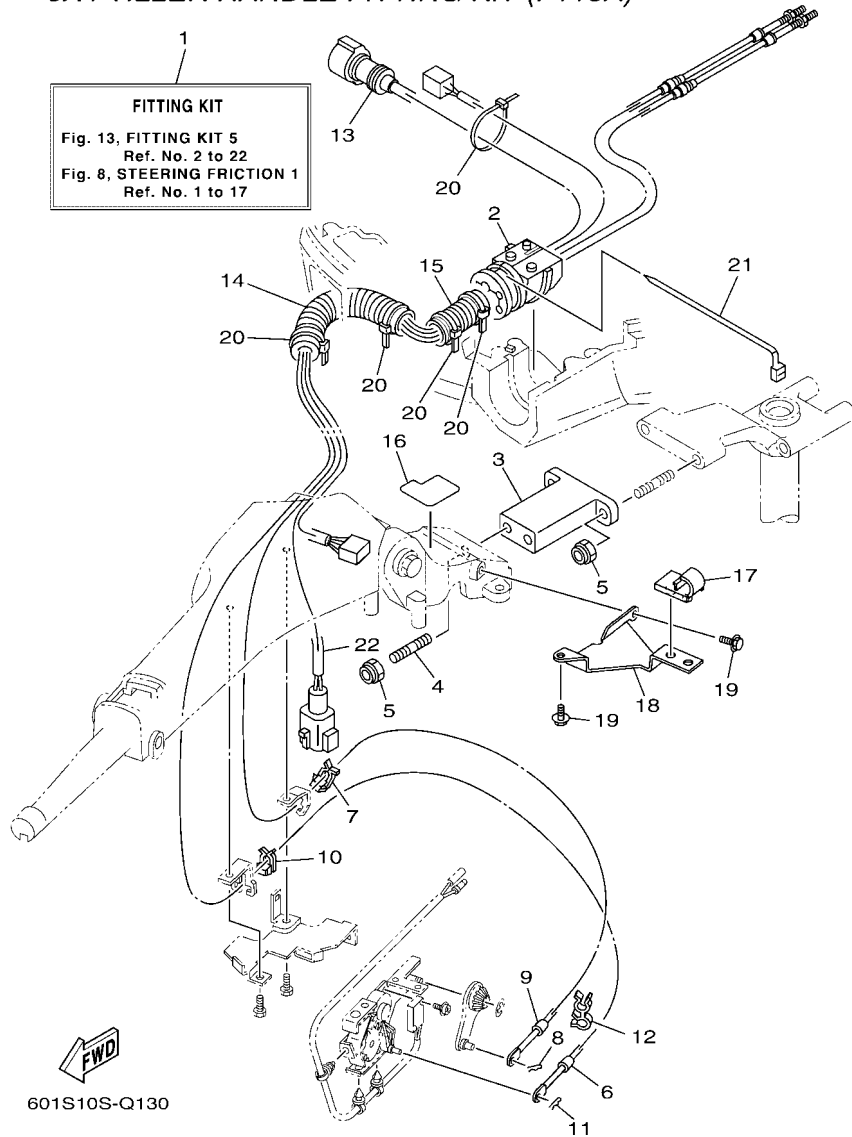

601S10S-Q130

FIG. 13 FITTING KIT 5

REF. NO.	PART NO.	DESCRIPTION	601S				REMARKS
1	6X4-42102-B1	FITTING KIT	1				LM
2	68V-42725-10	GROMMET	1				
3	6X4-42121-11-8D	BRACKET	1				
4	90116-10062	BOLT, STUD	2				
5	90185-10027	NUT, SELF-LOCKING	4				
6	67G-48321-20	CABLE	1				
7	63D-48538-00	CLAMP, CABLE 1	1				
8	90468-10005	CLIP	1				
9	67G-26301-10	THROTTLE CABLE ASSY	1				
10	63D-48538-00	CLAMP, CABLE 1	1				
11	90468-10005	CLIP	1				
12	90464-09M42	CLAMP	1				
13	6X4-82586-20	EXT., WIRE HARNESS (L:1.25M)	1				
14	90447-22007	TUBE	1				
15	6G5-83557-00	TUBE	1				
16	6X4-42735-00	PROTECTOR	1				
17	63D-24367-00	CLAMP, FUEL PIPE 2	1				
18	6X4-24364-00	STAY	1				
19	97595-06516	BOLT, WITH WASHER	2				
20	90465-13M24	CLAMP	5				
21	90465-13M30	CLAMP	1				
22	6X4-83653-00	WIRE, LEAD (L:1250MM)	1				

STEERING FRICTION

Part No.	Applicable model
6AH-42508-01	F8F(F8B), FT8G, F9.9J(F9.9B), F9.9H, FT9.9L(T9.9B), F15C (F15A), F20B (F20A), F20C
6AH-42508-11	FT9.9L(T9.9B), F15C (F15A), F20B (F20A)

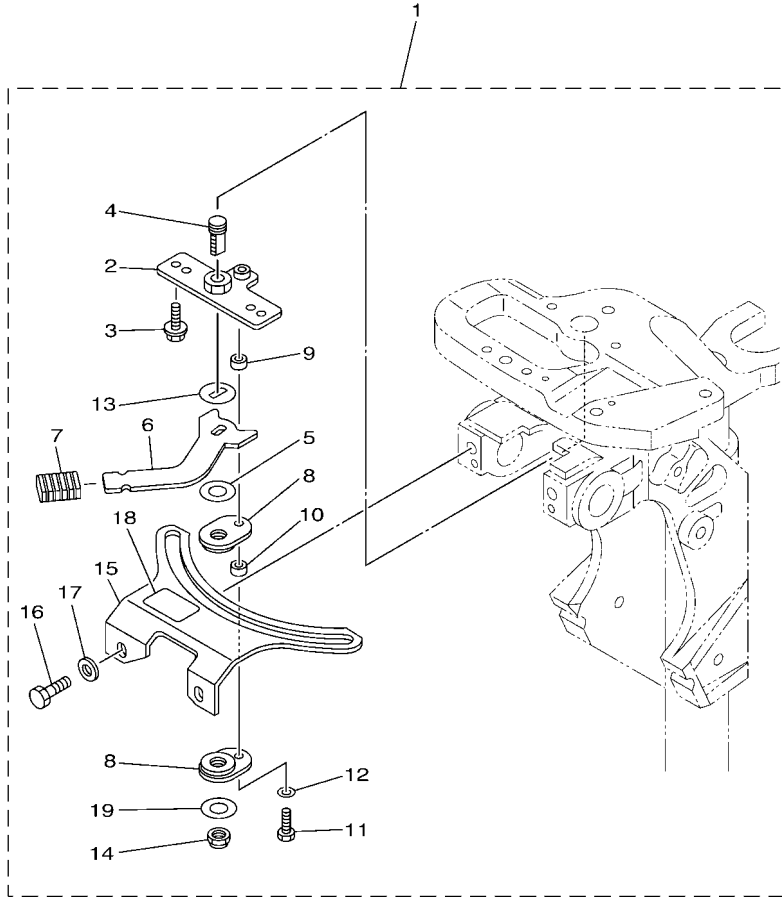

601S10S-Q140

FIG. 14 STEERING FRICTION 4

REF. NO.	PART NO.	DESCRIPTION	601S	REMARKS
1	6AH-42508-01	STEERING FRICTION ASSY	1	UR
	6AH-42508-11	STEERING FRICTION ASSY	1	UR
2	68T-42525-01	.PLATE, FRICTION	1	
3	90119-05018	.BOLT, WITH WASHER	2	
4	67C-42562-00	.SHAFT, STEERING LOCK	1	
5	90202-10M56	.WASHER, PLATE	1	
6	68T-42561-00	.KNOB, STEERING LOCK	1	
7	689-43633-00	.COVER, TILT LEVER	1	
8	65W-42528-00	.PLATE, FRICTION	2	
9	90387-05053	.COLLAR	1	
10	90387-05054	.COLLAR	1	
11	97095-05020	.BOLT	1	
12	92995-05600	.WASHER	1	
13	90209-10M26	.WASHER	1	
14	90185-10M14	.NUT, SELF-LOCKING	1	
15	6AH-42527-00	.PLATE, FRICTION	1	
16	90101-08022	.BOLT	2	
17	90201-08065	.WASHER, PLATE	2	
18	68T-43155-00	.MARK 1	1	FOR 6AH-42508-01
19	90201-106M5	.WASHER, PLATE	1	

STEERING FRICTION

Part No.	Applicable model
65W-42508-00	F25D (F25A/F25B), (E)40X

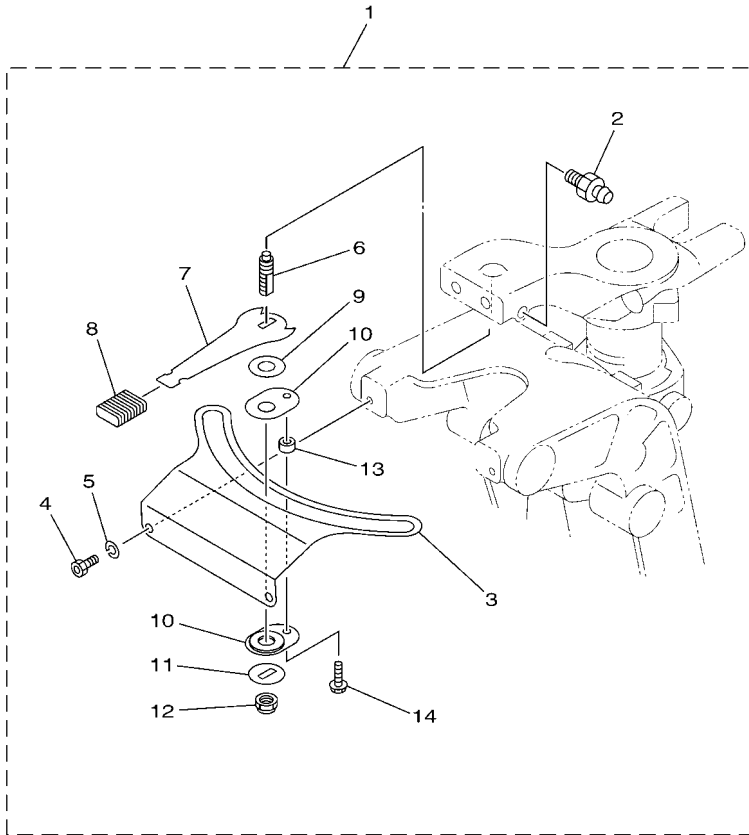

601S10S-M180

FIG. 15 STEERING FRICTION 5

REF. NO.	PART NO.	DESCRIPTION	601S				REMARKS
1	65W-42508-00	STEERING FRICTION ASSY	1				
2	93700-06M03	.NIPPLE, GREASE	1				
3	65W-42527-00	.PLATE, FRICTION	1				
4	90109-06M88	.BOLT	2				
5	92990-06100	.WASHER, SPRING	2				
6	65W-42562-00	.SHAFT, STEERING LOCK	1				
7	65W-42561-00	.KNOB, STEERING LOCK	1				
8	689-43633-00	.COVER, TILT LEVER	1				
9	90202-10M56	.WASHER, PLATE	1				
10	65W-42528-00	.PLATE, FRICTION	2				
11	90209-10M26	.WASHER	1				
12	90185-10M14	.NUT, SELF-LOCKING	1				
13	90387-05054	.COLLAR	1				
14	90109-05M89	.BOLT	1				

STEERING FRICTION

Part No.	Applicable model
67C-42508-04	F30B (F30A), F40F(F40A)

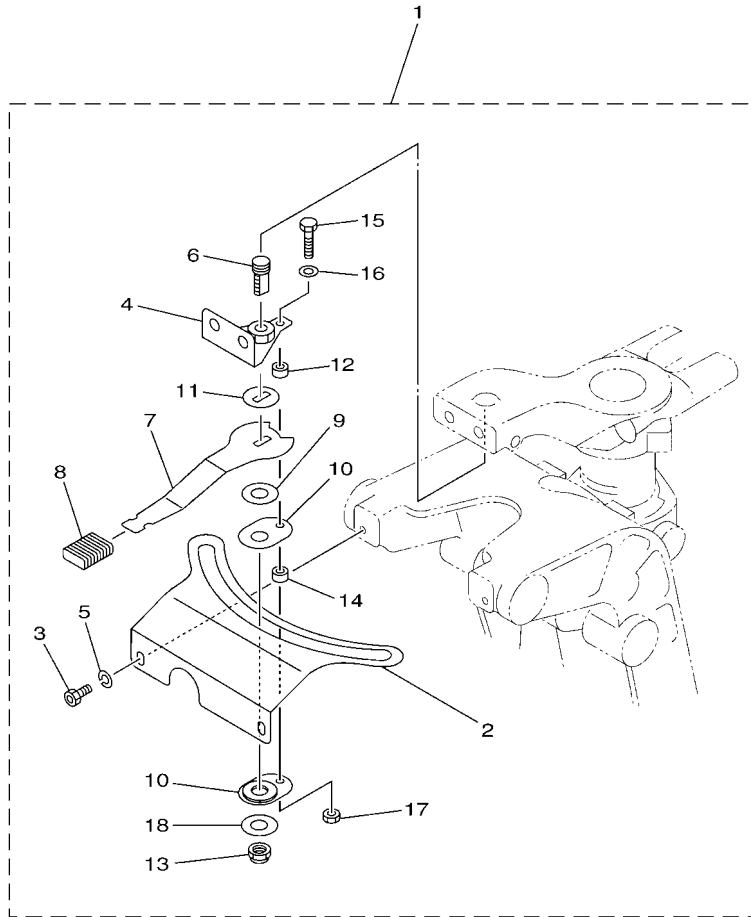



601S10S-L170

FIG. 16 STEERING FRICTION 6

REF. NO.	PART NO.	DESCRIPTION	601S				REMARKS
1	67C-42508-04	STEERING FRICTION ASSY	1				
2	67C-42527-03	.PLATE, FRICTION	1				
3	90109-06M88	.BOLT	2				
4	67C-42525-00	.PLATE, FRICTION	1				
5	92990-06100	.WASHER, SPRING	2				
6	67C-42562-00	.SHAFT, STEERING LOCK	1				
7	67C-42561-00	.KNOB, STEERING LOCK	1				
8	689-43633-00	.COVER, TILT LEVER	1				
9	90202-10M56	.WASHER, PLATE	1				
10	65W-42528-00	.PLATE, FRICTION	2				
11	90209-10M26	.WASHER	1				
12	90387-05053	.COLLAR	1				
13	90185-10M14	.NUT, SELF-LOCKING	1				
14	90387-05054	.COLLAR	1				
15	97095-05020	.BOLT	1				
16	92995-05600	.WASHER	1				
17	95380-05600	.NUT	1				
18	90201-106M5	.WASHER, PLATE	1				

STEERING FRICTION

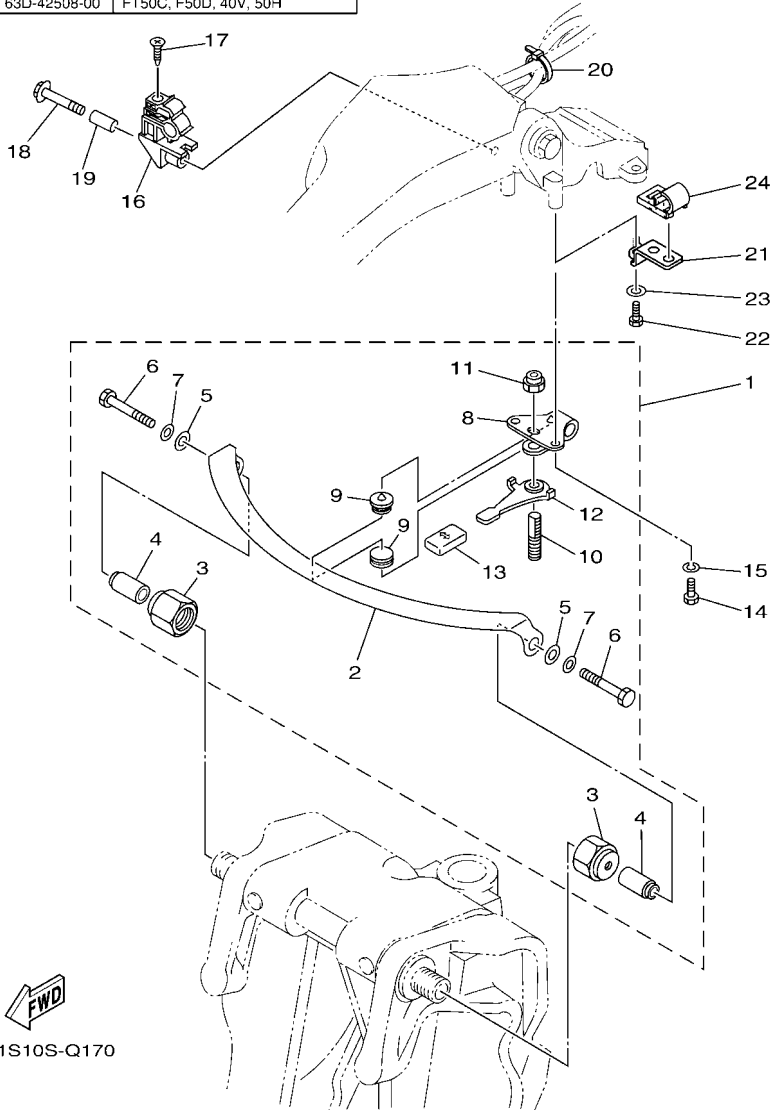
Part No.	Applicable model
63D-42508-00	FT50C, F50D, 40V, 50H



601S10S-Q170

FIG. 17 STEERING FRICTION 7

REF. NO.	PART NO.	DESCRIPTION	601S				REMARKS
1	63D-42508-00	STEERING FRICTION ASSY	1				
2	63D-42527-00	.PLATE, FRICTION	1				
3	63D-42546-00	.NUT	2				
4	63D-42541-00	.PIPE 1	2				
5	90201-08M01	.WASHER, PLATE	2				
6	97095-08050	.BOLT	2				
7	92990-08600	.WASHER, PLATE	2				
8	63D-42526-00	.PLATE, FRICTION	1				
9	63D-42528-00	.PLATE, FRICTION	2				
10	63D-42562-00	.SHAFT, STEERING LOCK	1				
11	90185-10M01	.NUT, SELF-LOCKING	1				
12	63D-42561-00	.KNOB, STEERING LOCK	1				
13	682-43318-01	.COVER	1				
14	97095-06016	BOLT	2				
15	92995-06100	WASHER, SPRING	2				
16	63D-82361-00	CLAMP, CORD	1				
17	90161-06M00	SCREW, TAPPING	1				
18	97595-06535	BOLT, WITH WASHER	1				
19	90387-06M26	COLLAR	1				
20	90465-13M36	CLAMP	1				
21	63D-24364-10	STAY	1				
22	97095-06016	BOLT	1				
23	92995-06600	WASHER	1				
24	63D-24367-00	CLAMP, FUEL PIPE 2	1				

STEERING FRICTION

Part No.	Applicable model
692-42508-01	55B, 55D, 60F, 70B, 90A

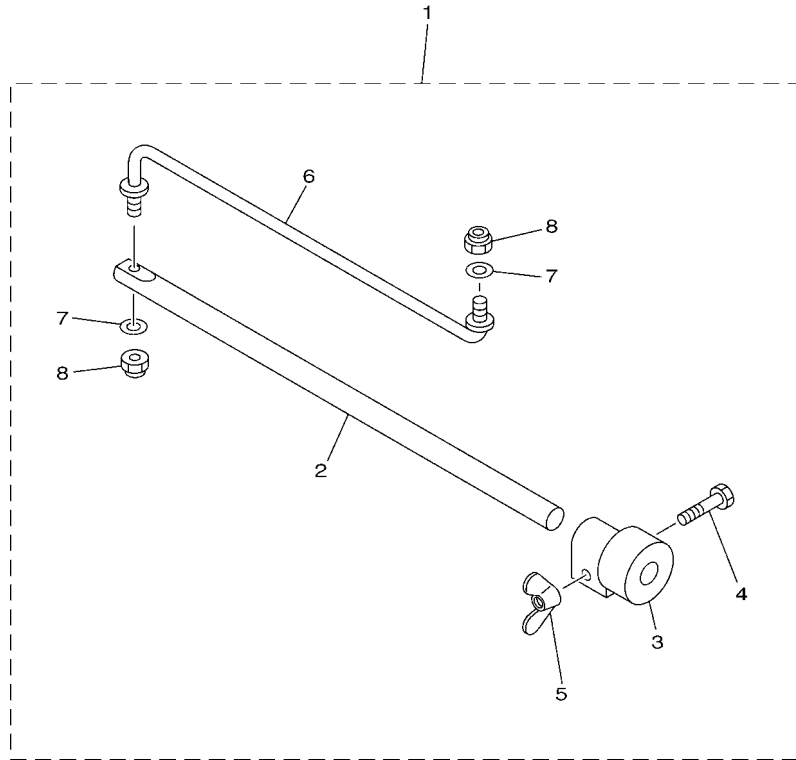

601S10S-N220

FIG. 18 STEERING FRICTION 8

REF. NO.	PART NO.	DESCRIPTION	601S				REMARKS
1	692-42508-01	STEERING FRICTION ASSY	1				
2	663-42518-00	.SHAFT, FRICTION	1				
3	663-42528-00	.PLATE, FRICTION	1				
4	97080-06035	.BOLT	1				
5	90175-06003	.NUT, WING	1				
6	692-42515-01	.ROD, STEERING LINK	1				
7	92990-08600	.WASHER, PLATE	2				
8	90185-08057	.NUT, SELF-LOCKING	2				

STEERING FRICTION

Part No.	Applicable model
6C5-42508-01	F50H (F50B), FT50J (T50B), F60F (F60B), FT60G (T60B)

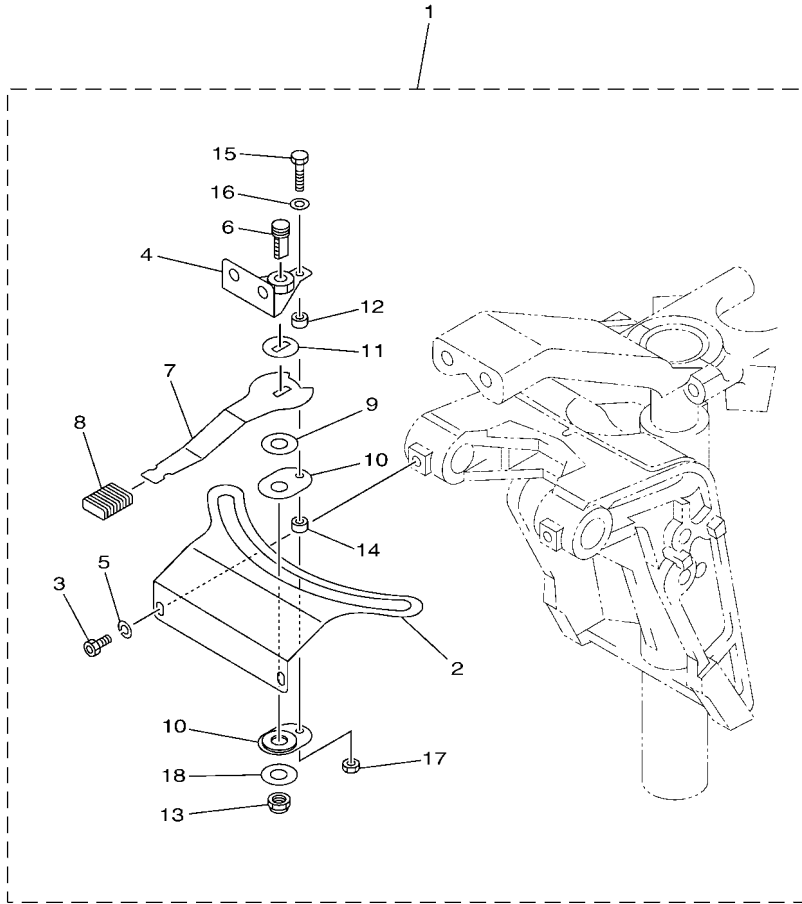

601S10S-Q190

FIG. 19 STEERING FRICTION 9

REF. NO.	PART NO.	DESCRIPTION	601S	REMARKS
1	6C5-42508-01	STEERING FRICTION ASSY	1	
2	6C5-42527-00	.PLATE, FRICTION	1	
3	90109-06M88	.BOLT	2	
4	67C-42525-00	.PLATE, FRICTION	1	
5	92990-06100	.WASHER, SPRING	2	
6	67C-42562-00	.SHAFT, STEERING LOCK	1	
7	67C-42561-00	.KNOB, STEERING LOCK	1	
8	689-43633-00	.COVER, TILT LEVER	1	
9	90202-10M56	.WASHER, PLATE	1	
10	65W-42528-00	.PLATE, FRICTION	2	
11	90209-10M26	.WASHER	1	
12	90387-05053	.COLLAR	1	
13	90185-10M14	.NUT, SELF-LOCKING	1	
14	90387-05054	.COLLAR	1	
15	97095-05020	.BOLT	1	
16	92995-05600	.WASHER	1	
17	95380-05600	.NUT	1	
18	90201-106M5	.WASHER, PLATE	1	

STEERING FRICTION

Part No.	Applicable model
67G-42508-10	F75B (F75A), F80B (F80A), F90B (F90A), F100D (F100A) F115A, F115B (F115B), F130A (F130A), F75C

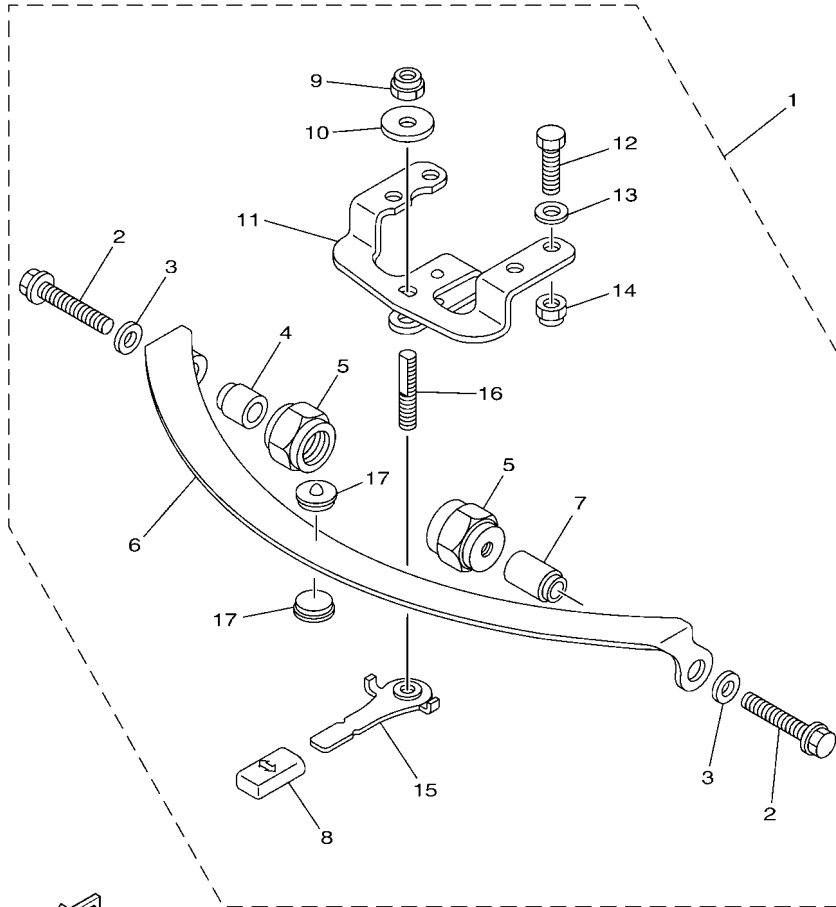

601S10S-Q200

FIG. 20 STEERING FRICTION 10

REF. NO.	PART NO.	DESCRIPTION	601S				REMARKS
1	67G-42508-10	STEERING FRICTION ASSY	1				
2	90119-08M74	.BOLT, WITH WASHER	2				
3	90201-08M01	.WASHER, PLATE	2				
4	67G-42541-00	.PIPE 1	1				
5	67G-42546-00	.NUT	2				
6	63D-42527-00	.PLATE, FRICTION	1				
7	67G-42541-10	.PIPE 1	1				
8	682-43318-01	.COVER	1				
9	90185-10M14	.NUT, SELF-LOCKING	1				
10	90201-10M76	.WASHER, PLATE	1				
11	6X4-42526-00	.PLATE, FRICTION	1				
12	97095-08025	.BOLT	2				
13	92995-08600	.WASHER	2				
14	90185-08057	.NUT, SELF-LOCKING	2				
15	67G-42561-00	.KNOB, STEERING LOCK	1				
16	67G-42562-00	.SHAFT, STEERING LOCK	1				
17	63D-42528-00	.PLATE, FRICTION	2				

NUMERICAL INDEX

PART NO.	REF. NO.	PART NO.	REF. NO.	PART NO.	REF. NO.	PART NO.	REF. NO.	PART NO.	REF. NO.	PART NO.	REF. NO.
6X4-14137-00	1 - 26	6X4-42137-00	1 - 7	67G-42541-00	20 - 4	6X4-44100-01	4 - 21	6X4-48538-10	1 - 37	6H4-83589-00	3 - 18
	4 - 26		4 - 7	67G-42541-10	8 - 7	6X4-44102-00	1 - 23		4 - 42	6X4-83653-00	7 - 23
6X4-24364-00	7 - 19	6X4-42159-00	1 - 40		20 - 7		4 - 23	6X4-81860-00	6 - 12		13 - 22
	13 - 18		4 - 47	63D-42546-00	17 - 3	6X4-44114-00	3 - 15		7 - 14	6X4-83653-20	3 - 13
63D-24364-10	17 - 21	6X4-42177-00	1 - 6	67G-42546-00	8 - 5	6X4-44132-00	1 - 25		9 - 11		9 - 13
63D-24367-00	7 - 18		4 - 6		20 - 5		4 - 25		11 - 11		11 - 13
	13 - 17	63D-42508-00	17 - 1	63D-42561-00	17 - 12	6X4-44139-01	1 - 9	6X4-81942-01	2 - 13	6C5-84301-00	3 - 14
	17 - 24	65W-42508-00	15 - 1	65W-42561-00	15 - 7		4 - 9		3 - 20	6X4-85415-00	3 - 19
69W-26301-00	9 - 6	692-42508-01	18 - 1	67C-42561-00	10 - 7	6X4-44159-00-4D	4 - 48		5 - 14	90101-08022	14 - 16
	11 - 6	6AH-42508-01	14 - 1		12 - 7	6X4-44159-00-8D	1 - 41	62Y-82361-00	5 - 16	90101-12014	1 - 50
6EK-26301-00	6 - 8	6C5-42508-01	10 - 1		16 - 7	6X4-44173-00	1 - 42	63D-82361-00	17 - 16		4 - 57
67G-26301-10	7 - 9		19 - 1		19 - 7		4 - 49	6X4-82510-01	2 - 1	90109-05M89	15 - 14
	13 - 9	67C-42508-04	12 - 1	67G-42561-00	8 - 15	6X4-44177-00	1 - 12		5 - 1	90109-06M88	10 - 3
6X4-26367-00	1 - 35		16 - 1		20 - 15		4 - 12	6X4-82510-41	3 - 1		12 - 3
	1 - 38	67G-42508-10	8 - 1	68T-42561-00	14 - 6	6X4-44188-00	1 - 15	703-82532-00	2 - 3		15 - 4
	4 - 36		20 - 1	63D-42562-00	17 - 10		4 - 15		3 - 3		16 - 3
	4 - 43	6AH-42508-11	14 - 1	65W-42562-00	15 - 6	6G8-44191-00	1 - 44		5 - 3		19 - 3
6X4-41291-00	1 - 8	692-42515-01	18 - 6	67C-42562-00	10 - 6		4 - 51	6X4-82540-00	1 - 28	90116-10031	7 - 5
	4 - 8	663-42518-00	18 - 2		12 - 6	6X4-47731-01	1 - 24		4 - 28	90116-10062	13 - 4
6X4-42102-11	7 - 1	67C-42525-00	10 - 4		14 - 4		4 - 24	682-82556-00	2 - 6	90116-10063	6 - 2
6X4-42102-23	9 - 1		12 - 4		16 - 6	703-48129-00	1 - 29		3 - 6	90119-05018	14 - 3
6X4-42102-71	11 - 1		16 - 4		19 - 6		4 - 29		5 - 6	90119-08M74	8 - 2
6X4-42102-81	11 - 1		19 - 4	67G-42562-00	8 - 16	6X4-48154-00	1 - 18	6X4-82563-00	2 - 8		20 - 2
6X4-42102-91	9 - 1	68T-42525-01	14 - 2		20 - 16		4 - 18		5 - 8	90152-05007	1 - 10
6X4-42102-A1	7 - 1	63D-42526-00	17 - 8	6X4-42725-01	1 - 48	6X4-48215-00	1 - 4	6X4-82563-01	3 - 8	90161-06M00	4 - 10
6X4-42102-B1	13 - 1	6X4-42526-00	8 - 11		4 - 55		4 - 4	69W-82575-00	2 - 5	90161-06M03	17 - 17
6X4-42102-C0	6 - 1		20 - 11	68V-42725-10	7 - 2	6X4-48261-00	1 - 27		3 - 5	90175-06003	5 - 17
6X4-42103-0A	4 - 1	63D-42527-00	8 - 6		13 - 2		4 - 27		5 - 5	90185-08057	18 - 5
6X4-42103-55	1 - 1		17 - 2	6X4-42727-00	3 - 17	6EK-48321-00	6 - 5	676-82577-01	2 - 2		8 - 14
6X4-42103-65	1 - 1		20 - 6	6X4-42728-00	9 - 14	6H3-48321-02	4 - 41		3 - 2		18 - 8
6X4-42111-02-4D	4 - 2	65W-42527-00	15 - 3		11 - 14	67C-48321-11	9 - 3		5 - 2		20 - 14
6X4-42111-02-8D	1 - 2	6AH-42527-00	14 - 15	6X4-42728-10	1 - 58		11 - 3	689-8257Y-00	2 - 7	90185-10027	5 - 23
6X4-42115-00	1 - 22	6C5-42527-00	10 - 2		4 - 65	67G-48321-20	7 - 6		3 - 7		6 - 3
	4 - 22		19 - 2	6X4-42735-00	7 - 17		13 - 6		5 - 7		7 - 4
6X4-42119-01	1 - 5	67C-42527-03	12 - 2		13 - 16	6H1-48321-21	4 - 34	6X4-82586-10	5 - 10		9 - 2
	4 - 5		16 - 2	6X4-42821-00	1 - 30	63D-48538-00	4 - 39		6 - 10		11 - 2
6EK-42121-00	6 - 4	63D-42528-00	8 - 17		4 - 30		4 - 45		9 - 10		13 - 5
6X4-42121-00-8D	7 - 3		17 - 9	68T-43155-00	14 - 18		6 - 7		11 - 10	90185-10M01	17 - 11
65W-42121-11-4D	4 - 56		20 - 17	682-43318-01	8 - 8		7 - 7	6X4-82586-20	7 - 13	90185-10M14	8 - 9
6X4-42121-11-8D	13 - 3	65W-42528-00	10 - 10		17 - 13		7 - 10		13 - 13		10 - 13
63D-42121-22-8D	1 - 49		12 - 10		20 - 8		9 - 4	6X4-83383-00	2 - 10		12 - 13
63D-42126-00	1 - 17		14 - 8	689-43633-00	10 - 8		9 - 7		3 - 10		14 - 14
	4 - 17		15 - 10		12 - 8		11 - 4		5 - 11		15 - 12
6X4-42128-00	1 - 13		16 - 10		14 - 7		11 - 7	6X4-83386-00	2 - 11		16 - 13
	4 - 13		19 - 10		15 - 8		13 - 7		3 - 11		19 - 13
6X4-42131-01	1 - 46	663-42528-00	18 - 3		16 - 8		13 - 10		5 - 12		20 - 9
	4 - 53	63D-42541-00	17 - 4		19 - 8	6X4-48538-00	1 - 34	6G5-83557-00	13 - 15	90185-12M12	1 - 57
6X4-42131-11	1 - 46	67G-42541-00	8 - 4	6X4-44100-01	1 - 21		4 - 35	6K3-83557-00	7 - 16		4 - 64

NUMERICAL INDEX

PART NO.	REF. NO.	PART NO.	REF. NO.	PART NO.	REF. NO.	PART NO.	REF. NO.	PART NO.	REF. NO.	PART NO.	REF. NO.
90201-08065	14 - 17	90447-22006	5 - 21	92990-12600	1 - 56	97595-06535	17 - 18				
90201-08M01	8 - 3	90447-22007	7 - 15		4 - 63	97780-60620	3 - 16				
	17 - 5		13 - 14	92990-12600	10 - 16	97780-60920	1 - 43				
	20 - 3	90464-08M07	2 - 4		12 - 16		4 - 50				
90201-106M5	10 - 18		3 - 4		14 - 12	97980-06216	2 - 9				
	12 - 18		5 - 4		16 - 16		3 - 9				
	14 - 19	90464-09M42	4 - 37		19 - 16		5 - 9				
	16 - 18		6 - 9	92995-06100	17 - 15	97985-06216	1 - 47				
	19 - 18		7 - 12	92995-06600	5 - 19		4 - 54				
90201-10M76	8 - 10		9 - 9		17 - 23						
	20 - 10		11 - 9	92995-08600	1 - 32						
90201-12035	1 - 54		13 - 12		4 - 32						
	4 - 61	90465-13M24	5 - 22		8 - 13						
90202-10M56	10 - 9		6 - 11		20 - 13						
	12 - 9		7 - 21	93700-06M03	1 - 3						
	14 - 5		13 - 20		4 - 3						
	15 - 9	90465-13M30	7 - 22		15 - 2						
	16 - 9		13 - 21	95380-05600	10 - 17						
	19 - 9	90465-13M36	5 - 15		12 - 17						
90206-12M22	1 - 52		9 - 12		16 - 17						
	4 - 59		11 - 12		19 - 17						
90209-10M26	10 - 11		17 - 20	95380-06600	1 - 19						
	12 - 11	90468-10005	4 - 40		4 - 19						
	14 - 13		4 - 46	97080-06035	18 - 4						
	15 - 11		6 - 6	97095-05020	10 - 15						
	16 - 11		7 - 8		12 - 15						
	19 - 11		7 - 11		14 - 11						
90386-08032	1 - 16		9 - 5		16 - 15						
	4 - 16		9 - 8		19 - 15						
90386-12003	1 - 55		11 - 5	97095-06014	1 - 36						
	4 - 62		11 - 8		1 - 39						
90386-26MA3	1 - 45		13 - 8		2 - 12						
	4 - 52		13 - 11		3 - 12						
90387-05053	10 - 12	90501-23215	1 - 14		4 - 38						
	12 - 12		4 - 14		4 - 44						
	14 - 9	91490-20010	1 - 11		5 - 13						
	16 - 12		1 - 20	97095-06016	17 - 14						
	19 - 12		4 - 11		17 - 22						
90387-05054	10 - 14		4 - 20	97095-06035	5 - 18						
	12 - 14	92990-06100	10 - 5	97095-08025	8 - 12						
	14 - 10		12 - 5		20 - 12						
	15 - 13		15 - 5	97095-08040	1 - 31						
	16 - 14		16 - 5		4 - 31						
	19 - 14		19 - 5	97095-08050	17 - 6						
90387-06M26	5 - 20	92990-08600	17 - 7	97595-06516	7 - 20						
	17 - 19		18 - 7		13 - 19						
90387-12M02	1 - 53	92990-12200	1 - 51	97595-06530	1 - 33						
	4 - 60		4 - 58		4 - 33						