



# **PARTS CATALOGUE**

# **RIGGING-STEERING**

---

RIGGING-STEERING  
PARTS CATALOGUE  
©2012 by Yamaha Motor Co., Ltd.  
1st edition, September 2012  
All rights reserved.  
Any reprinting or unauthorized use  
without the written permission of  
Yamaha Motor Co., Ltd.  
is expressly prohibited.  
Printed in Japan.

# FOREWORD

This Parts Catalogue is related to the parts for the model(s) on the cover page. When you are ordering replacement parts, please refer to this Parts Catalogue and quote both part numbers and part names correctly.

1. Modifications or additions which have been made after the issue of the Parts Catalogue will be announced in the Parts News.

It is advisable that you make the necessary corrections to the Parts Catalogue according to the Parts News.

2. Abbreviations

The following abbreviations are used in this Parts Catalogue.

“UR” Use specified parts number.

“UN” Use as many as needed.

“AP” Alternate Parts

“LM” Locally Made (Parts need to be ordered locally)

“F#” Frame No. (Applicable machine No.)

“O/S” Over Size

3. The number of components for assembly

- Parts, which are to be supplied in an assembly, are listed with a dot (.) in front of the part name as shown below.
- The numeral appearing to the right of each component part indicates the quantity of parts for each assembly unit.

PART NO.	DESCRIPTION	Q'TY	REMARKS
2F5-83310-60	FRONT FLASHER LIGHT ASSY	2	
115-83311-60	.BULB (6V-18W)	1	

4. Applicable colours of graphics are represented in the “REMARKS” as shown below.

PART NO.	DESCRIPTION	Q'TY	REMARKS
2N4-24110-00-X5	FUEL TANK COMP.	2	MXR
3J1-24240-10	.GRAPHIC, FUEL TANK	1	FOR MXR

5. Note that the illustrations for reference in finding parts numbers are not to be used for assembling. When assembling, please use the applicable service manual.

6. The asterisk (\*) before a reference number indicates modified items after the first edition.

# CONTENTS

BASE HANDLE - ALL .....	1
BASE HANDLE ELECTRICAL .....	4
FITTING KIT 1 .....	5
FITTING KIT 2 .....	6
STEERING FRICTION 1 .....	7
FITTING KIT 3 .....	8
STEERING FRICTION 2 .....	9
FITTING KIT 4 .....	10
FITTING KIT 5 .....	11
STEERING FRICTION 3 .....	12
FITTING KIT 6 .....	13
STEERING FRICTION 4 .....	14
FITTING KIT 7 .....	15
STEERING FRICTION 5 .....	16
STEERING FRICTION 6 .....	17
STEERING FRICTION 7 .....	18
STEERING FRICTION 8 .....	19
STEERING FRICTION 9 .....	20
STEERING FRICTION 10 .....	21
STEERING FRICTION 11 .....	22
STEERING FRICTION 12 .....	23
STEERING FRICTION 13 .....	24

## INDEX

NUMERICAL INDEX .....	25
-----------------------	----

# Application Model

			PART NO. / PART NAME							
			FIG.NO.							
MODEL CODE	MODEL NAME	SERIAL NO.	6X4-42103-50 HANDLE, STEERING	6X4-42102-00 FITTING KIT	6X4-42102-10 FITTING KIT	6X4-42102-22 FITTING KIT	6X4-42102-41 FITTING KIT	6X4-42102-51 FITTING KIT	6X4-42102-61 FITTING KIT	6X4-42102-70 FITTING KIT
			FIG.1, 2	FIG.3, 5	FIG.4, 5	FIG.6, 7	FIG.8, 10	FIG.9, 10	FIG.11, 12	FIG.13, 14
68VB	F115-2012	68V:1124466-	*	*						
6D68	F75-2012	62P:1013956-	*		*					
6D88	F90-2012	61P:1050228-	*		*					
6C18	F50-2012	6C1:1042224-	*			*				
6C58	F60-2012	6C5:1049208-	*			*				
6C28	T50-2012	6C2:1012253-	*			*				
6C68	T60-2012	6C6:1018352-	*			*				
6CJ2	F70-2012	6CJ:1011120-	*			*				
6H1E	90-2012	6H1:1046544-	*				*			
6H3B	70-2012	6H3K:1015090-	*					*		
62XN	50-2012	6H5K:1031324-	*						*	
6BG4	F40(FI)-2012	6BG:1019903-	*							*

6X4 TILLER HANDLE KIT (50-90 & F40-F115)

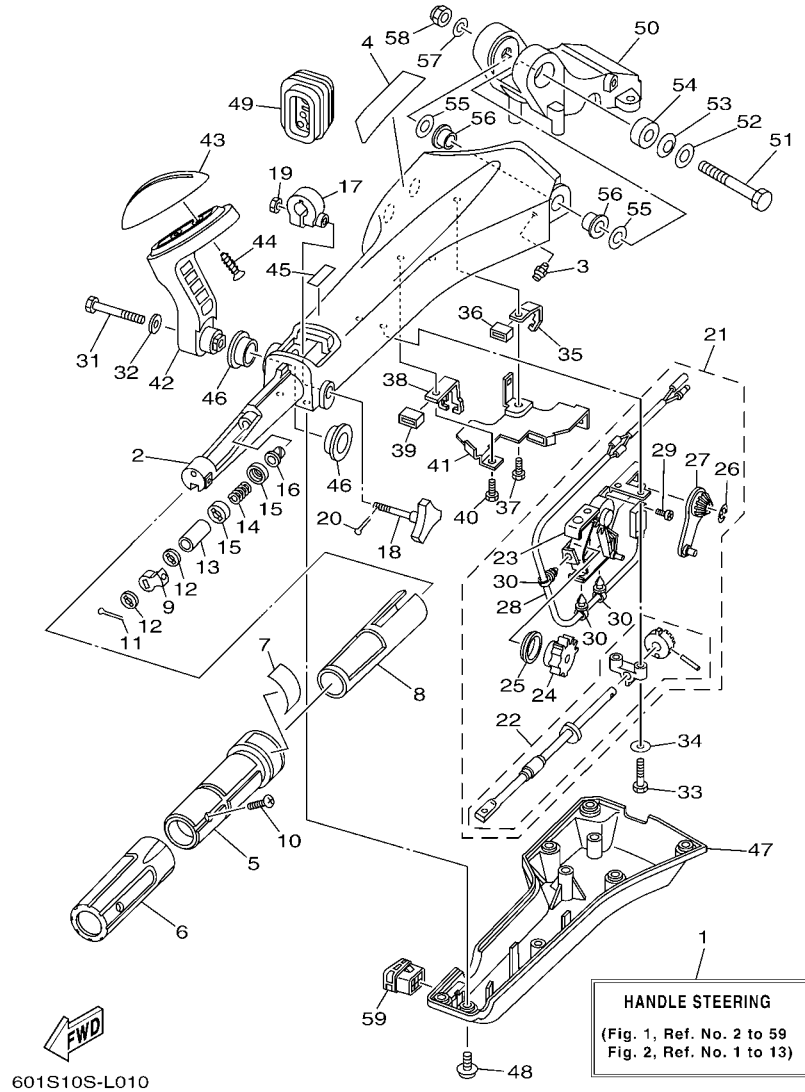

FIG. 1 BASE HANDLE - ALL

REF. NO.	PART NO.	DESCRIPTION	601S				REMARKS
1	6X4-42103-50	TILLER HANDLE KIT	1				LM
2	6X4-42111-02-8D	HANDLE, STEERING	1				
3	93700-06M03	NIPPLE, GREASE	1				
4	6X4-48215-00	GRAPHIC	1				
5	6X4-42119-01	GRIP, STEERING HANDLE	1				
6	6X4-42177-00	RUBBER, HANDLE	1				
7	6X4-42137-00	INDICATOR, THROTTLE	1				
8	6X4-41291-00	BUSHING	1				
9	6X4-44139-01	COLLAR	1				
10	90152-05007	SCREW, COUNTERSUNK	1				
11	91490-20010	PIN. COTTER	1				
12	6X4-44177-00	WASHER	2				
13	6X4-42128-00	COLLAR, DISTANCE 1	1				
14	90501-23215	SPRING, COMPRESSION	1				
15	6X4-44188-00	WASHER	2				
16	90386-08032	BUSH	1				
17	63D-42126-00	FRICION, STEERING HANDLE GRIP	1				
18	6X4-48154-00	KNOB, THROTTLE	1				
19	95380-06600	NUT, HEXAGON	1				
20	91490-20010	PIN. COTTER	1				
21	6X4-44100-00	SHIFT LINK ASSY	1				
22	6X4-42115-00	.SHAFT, STEERING HANDLE	1				
23	6X4-44102-00	.SHIFT ASSIST ASSY.	1				
24	6X4-47731-00	.GEAR, DRIVE	1				
25	6X4-44132-00	.BUSHING	1				
26	6X4-14137-00	.CLIP	1				
27	6X4-48261-00	.ARM, THROTTLE	1				

6X4 TILLER HANDLE KIT (50-90 & F40-F115)

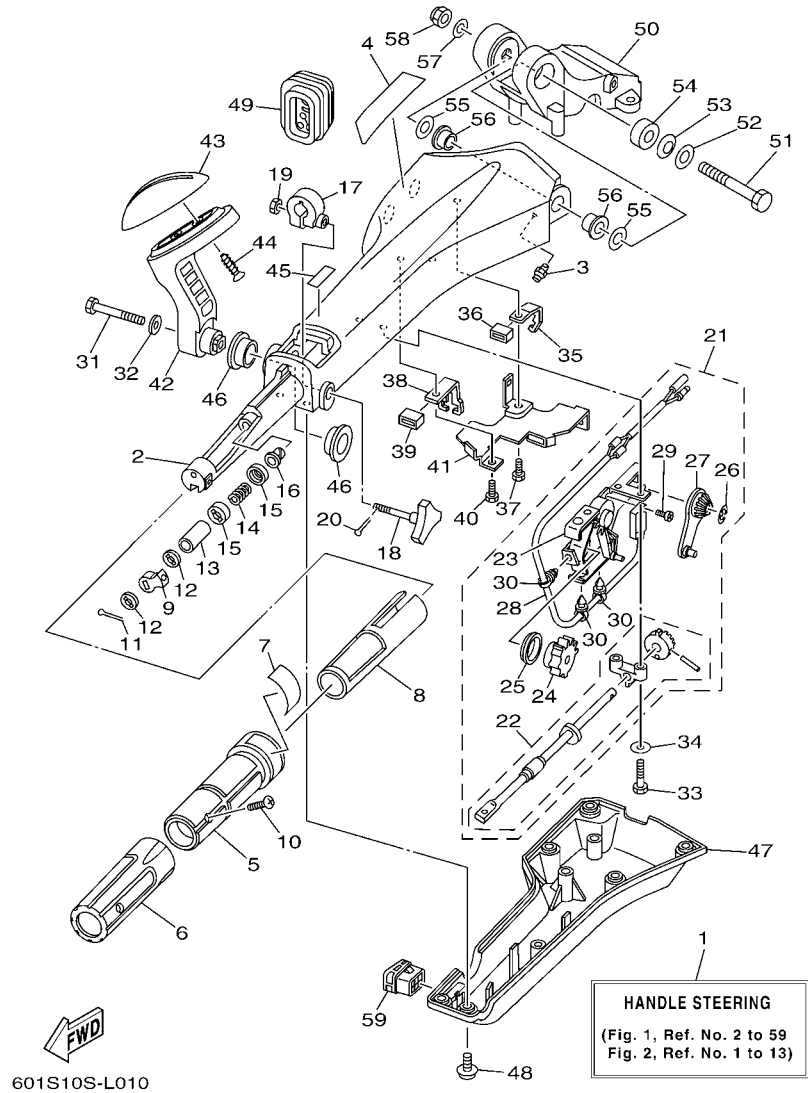

FIG. 1 BASE HANDLE - ALL

REF. NO.	PART NO.	DESCRIPTION	601S				REMARKS
28	6X4-82540-00	.NEUTRAL SWITCH ASSY	1				
29	6A5-48129-10	.SCREW 3	2				
30	6X4-42821-00	.BAND, CLAMP	3				
31	97095-08040	BOLT	1				
32	92995-08600	WASHER	1				
33	97095-06030	BOLT	2				
34	92995-06600	WASHER	2				
35	6X4-48538-00	CLAMP, CABLE 1	1				
36	6X4-26367-00	PROTECTOR	1				
37	97095-06014	BOLT	1				
38	6X4-48538-10	CLAMP, CABLE 1	1				
39	6X4-26367-00	PROTECTOR	1				
40	97095-06014	BOLT	1				
41	6X4-42159-00	STAY	1				
42	6X4-44159-00-8D	HANDLE, GEAR SHIFT	1				
43	6X4-44173-00	LEVER, SHIFT CONTROL	1				
44	97780-60920	SCREW, TAPPING	2				
45	6G8-44191-00	INDICATOR, SHIFT	1				
46	90386-26MA3	BUSH	2				
47	6X4-42131-01	COVER, HANDLE STEERING	1				
48	97985-06216	SCREW, WITH WASHER	6				
49	6X4-42725-01	GROMMET	1				
50	63D-42121-22-8D	BRACKET	1				
51	90101-12014	BOLT	1				
52	92990-12200	WASHER, PLAIN	1				
53	90206-12M22	WASHER, WAVE	1				
54	90387-12M02	COLLAR	1				







### 6X4 TILLER HANDLE FITTING KIT (F115)

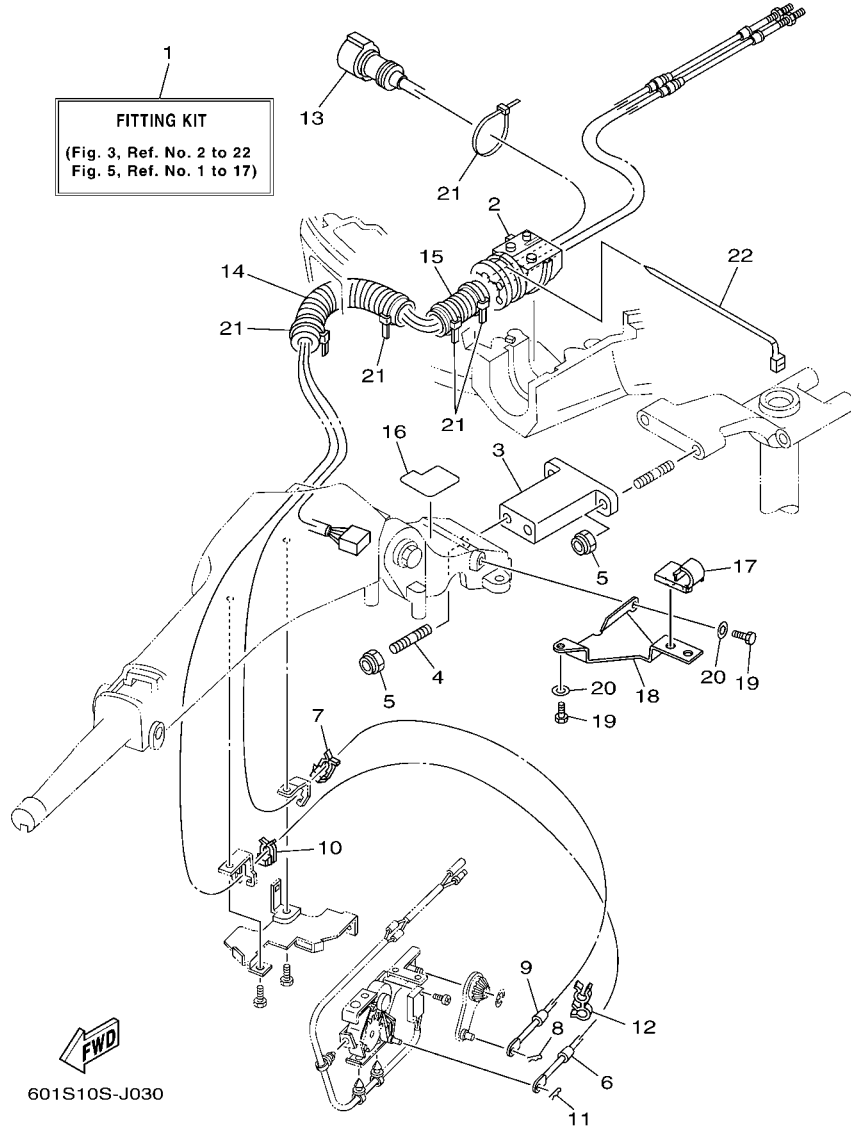

601S10S-J030

### FIG. 3 FITTING KIT 1

REF. NO.	PART NO.	DESCRIPTION	601S				REMARKS
1	6X4-42102-00	FITTING KIT	1				LM
2	68V-42725-10	GROMMET	1				
3	6X4-42121-11-8D	BRACKET	1				
4	90116-10175	BOLT, STUD	2				
5	90185-10051	NUT, SELF-LOCKING	4				
6	67G-48321-20	CABLE	1				
7	63D-48538-00	CLAMP, CABLE 1	1				
8	90468-10005	CLIP	1				
9	67G-26301-10	THROTTLE CABLE ASSY	1				
10	63D-48538-00	CLAMP, CABLE 1	1				
11	90468-10005	CLIP	1				
12	90464-09M42	CLAMP	1				
13	6X4-82586-20	EXT., WIRE HARNESS (L:1.25M)	1				
14	90447-22007	TUBE	1				
15	6G5-83557-00	TUBE	1				
16	6X4-42735-00	PROTECTOR	1				
17	63D-24367-00	CLAMP, FUEL PIPE 2	1				
18	6X4-24364-00	STAY	1				
19	97095-06016	BOLT	2				
20	92995-06600	WASHER	2				
21	90465-13M24	CLAMP	5				
22	90465-13M30	CLAMP	1				

### 6X4 TILLER HANDLE FITTING KIT (F75,F90)

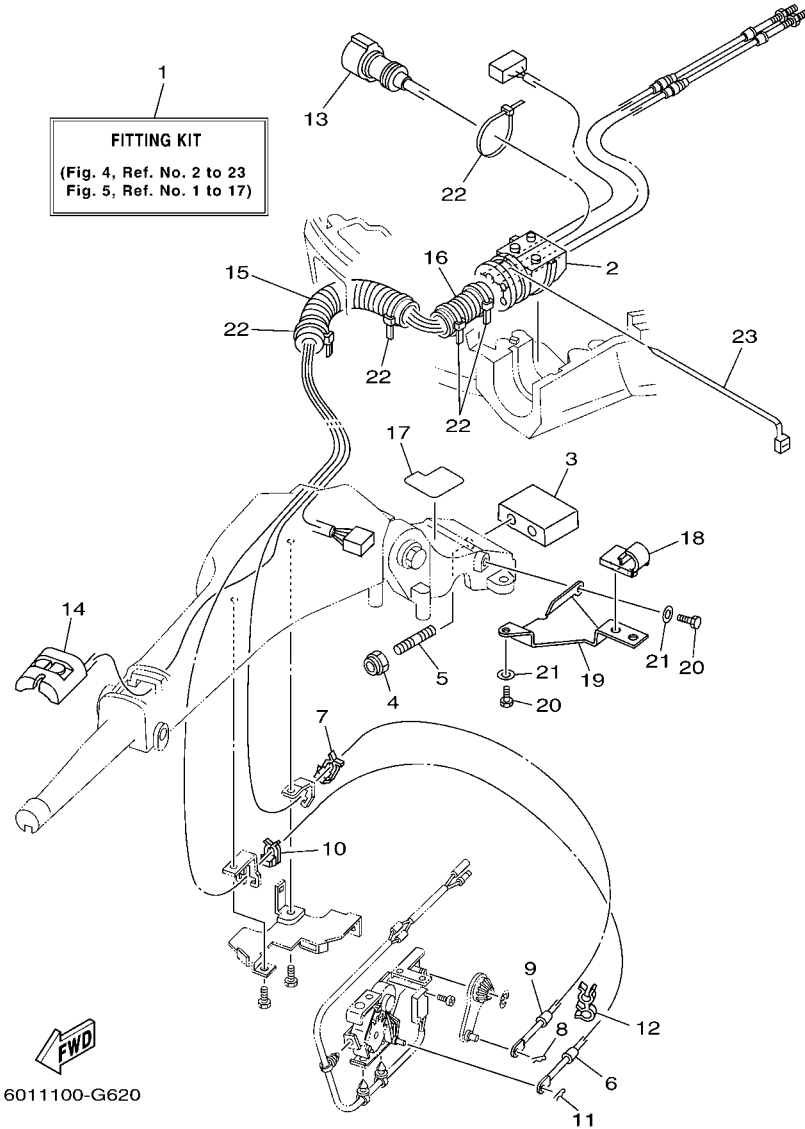

6011100-G620

### FIG. 4 FITTING KIT 2

REF. NO.	PART NO.	DESCRIPTION	QTY	REMARKS
1	6X4-42102-10	FITTING KIT	1	LM
2	68V-42725-10	GROMMET	1	
3	6X4-42121-00-8D	BRACKET	1	
4	90185-10051	NUT, SELF-LOCKING	2	
5	90116-10031	BOLT, STUD	2	
6	67G-48321-20	CABLE	1	
7	63D-48538-00	CLAMP, CABLE 1	1	
8	90468-10005	CLIP	1	
9	67G-26301-10	THROTTLE CABLE ASSY	1	
10	63D-48538-00	CLAMP, CABLE 1	1	
11	90468-10005	CLIP	1	
12	90464-09M42	CLAMP	1	
13	6X4-82586-20	EXT., WIRE HARNESS (L:1.25M)	1	
14	6X4-81860-00	SWITCH ASSY	1	
15	90447-22007	TUBE	1	
16	6K3-83557-00	TUBE	1	
17	6X4-42735-00	PROTECTOR	1	
18	63D-24367-00	CLAMP, FUEL PIPE 2	1	
19	6X4-24364-00	STAY	1	
20	97095-06016	BOLT	2	
21	92995-06600	WASHER	2	
22	90465-13M24	CLAMP	5	
23	90465-13M30	CLAMP	1	

**6X4 TILLER HANDLE FITTING KIT  
STEERING FRICTION (F75,F90,F115)**

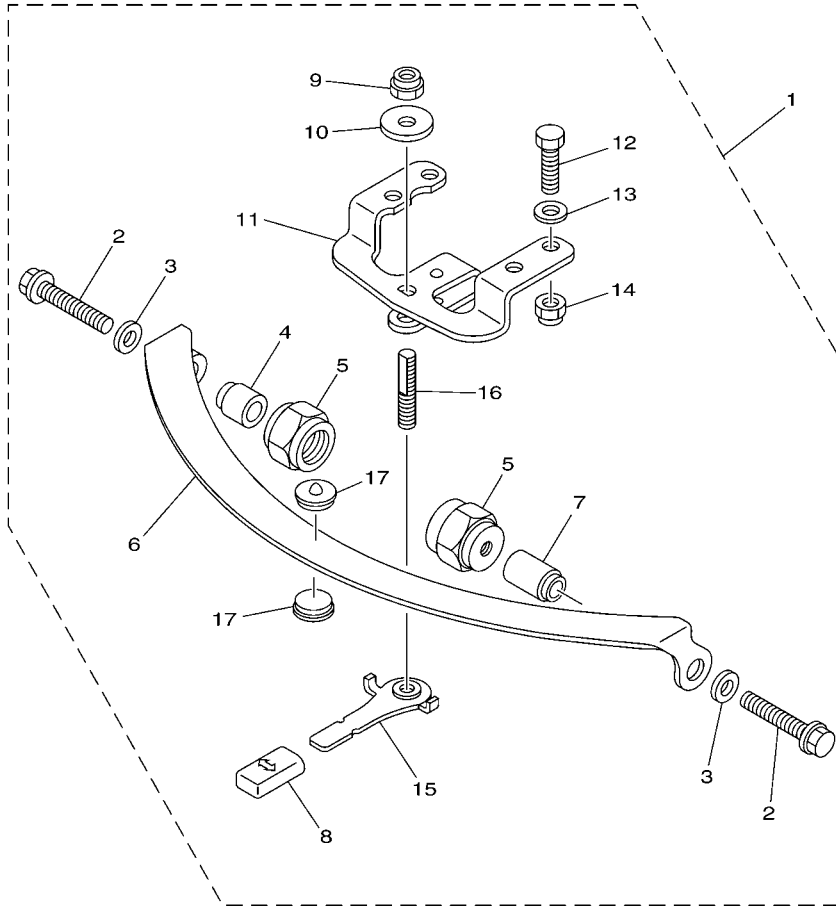

6011100-G630

**FIG. 5 STEERING FRICTION 1**

REF. NO.	PART NO.	DESCRIPTION	QTY				REMARKS
1	67G-42508-10	STEERING FRICTION ASSY	1				
2	90119-08M74	.BOLT, WITH WASHER	2				
3	90201-08M01	.WASHER, PLATE	2				
4	67G-42541-00	.PIPE 1	1				
5	67G-42546-00	.NUT	2				
6	63D-42527-00	.PLATE, FRICTION	1				
7	67G-42541-10	.PIPE 1	1				
8	682-43318-01	.COVER	1				
9	90185-10M14	.NUT, SELF-LOCKING	1				
10	90201-10M76	.WASHER, PLATE	1				
11	6X4-42526-00	.PLATE, FRICTION	1				
12	97095-08025	.BOLT	2				
13	92995-08600	.WASHER	2				
14	90185-08057	.NUT, SELF-LOCKING	2				
15	67G-42561-00	.KNOB, STEERING LOCK	1				
16	67G-42562-00	.SHAFT, STEERING LOCK	1				
17	63D-42528-00	.PLATE, FRICTION	2				



6X4 TILLER HANDLE FITTING KIT  
STEERING FRICTION (F50, T50, F60, T60, F70)

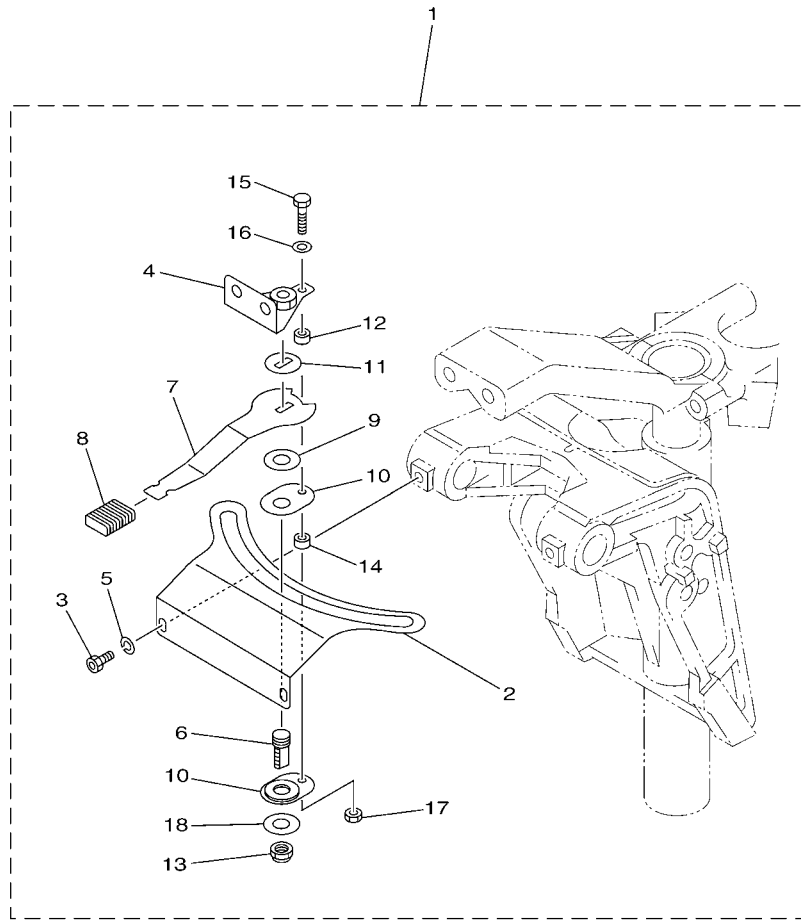

  
601S10S-L070

FIG. 7 STEERING FRICTION 2

REF. NO.	PART NO.	DESCRIPTION	601S				REMARKS
1	6C5-42508-01	STEERING FRICTION ASSY	1				
2	6C5-42527-00	.PLATE, FRICTION	1				
3	90109-06M88	.BOLT	2				
4	67C-42525-00	.PLATE, FRICTION	1				
5	92990-06100	.WASHER, SPRING	2				
6	67C-42562-00	.SHAFT, STEERING LOCK	1				
7	67C-42561-00	.KNOB, STEERING LOCK	1				
8	689-43633-00	.COVER, TILT LEVER	1				
9	90202-10M56	.WASHER, PLATE	1				
10	65W-42528-00	.PLATE, FRICTION	2				
11	90209-10M26	.WASHER	1				
12	90387-05053	.COLLAR	1				
13	90185-10M14	.NUT, SELF-LOCKING	1				
14	90387-05054	.COLLAR	1				
15	97095-05020	.BOLT	1				
16	92995-05600	.WASHER	1				
17	95380-05600	.NUT	1				
18	90201-106M5	.WASHER, PLATE	1				

### 6X4 TILLER HANDLE FITTING KIT (90)

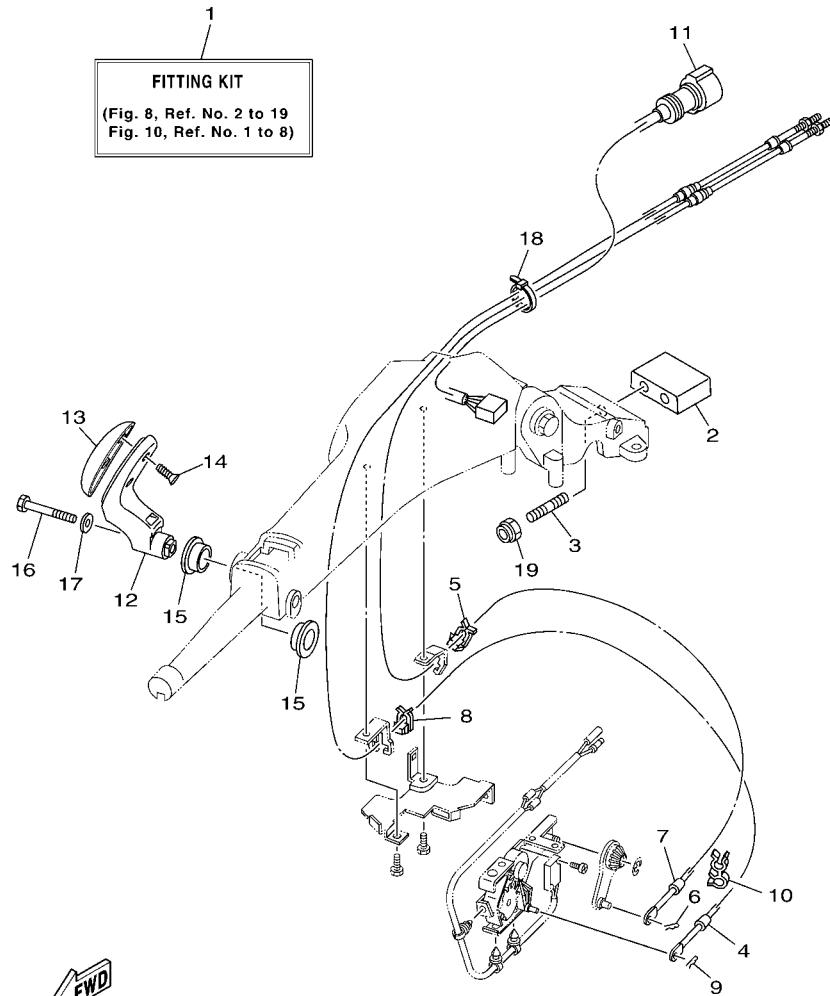

601S10S-J080

### FIG. 8 FITTING KIT 4

REF. NO.	PART NO.	DESCRIPTION	601S				REMARKS
1	6X4-42102-41	FITTING KIT	1				LM
2	6X4-42121-00-8D	BRACKET	1				
3	90116-10031	BOLT, STUD	2				
4	6H1-48321-11	CABLE	1				
5	63D-48538-00	CLAMP, CABLE 1	1				
6	90468-10005	CLIP	1				
7	6H1-26301-01	THROTTLE CABLE ASSY	1				
8	63D-48538-00	CLAMP, CABLE 1	1				
9	90468-10005	CLIP	1				
10	90464-09M42	CLAMP	1				
11	6X4-82586-30	EXTENSION, WIRE HARNESS	1				
12	6X4-44159-10-8D	HANDLE, GEAR SHIFT	1				
13	6X4-44173-00	LEVER, SHIFT CONTROL	1				
14	97780-60920	SCREW, TAPPING	2				
15	90386-26MA3	BUSH	1				
16	97095-08040	BOLT	1				
17	92995-08600	WASHER	1				
18	90465-13M36	CLAMP	1				
19	90185-10051	NUT, SELF-LOCKING	2				

### 6X4 TILLER HANDLE FITTING KIT (70)

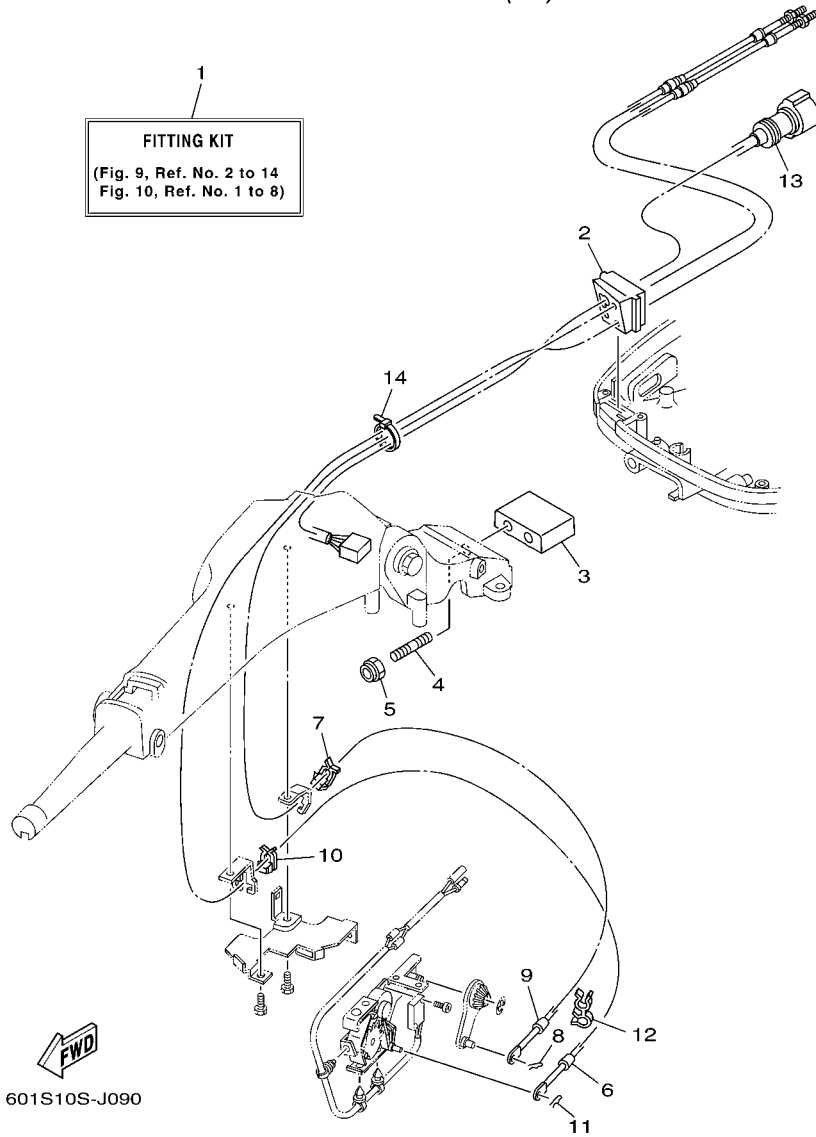

### FIG. 9 FITTING KIT 5

REF. NO.	PART NO.	DESCRIPTION	601S				REMARKS
1	6X4-42102-51	FITTING KIT	1				LM
2	6H3-42725-30	GROMMET	1				
3	6X4-42121-00-8D	BRACKET	1				
4	90116-10031	BOLT, STUD	2				
5	90185-10051	NUT, SELF-LOCKING	2				
6	6H3-48321-11	CABLE	1				
7	63D-48538-00	CLAMP, CABLE 1	1				
8	90468-10005	CLIP	1				
9	6H3-26301-01	THROTTLE CABLE ASSY	1				
10	63D-48538-00	CLAMP, CABLE 1	1				
11	90468-10005	CLIP	1				
12	90464-09M42	CLAMP	1				
13	6X4-82586-30	EXTENSION, WIRE HARNESS	1				
14	90465-13M36	CLAMP	1				







6X4 TILLER HANDLE FITTING KIT  
STEERING FRICTION (50)

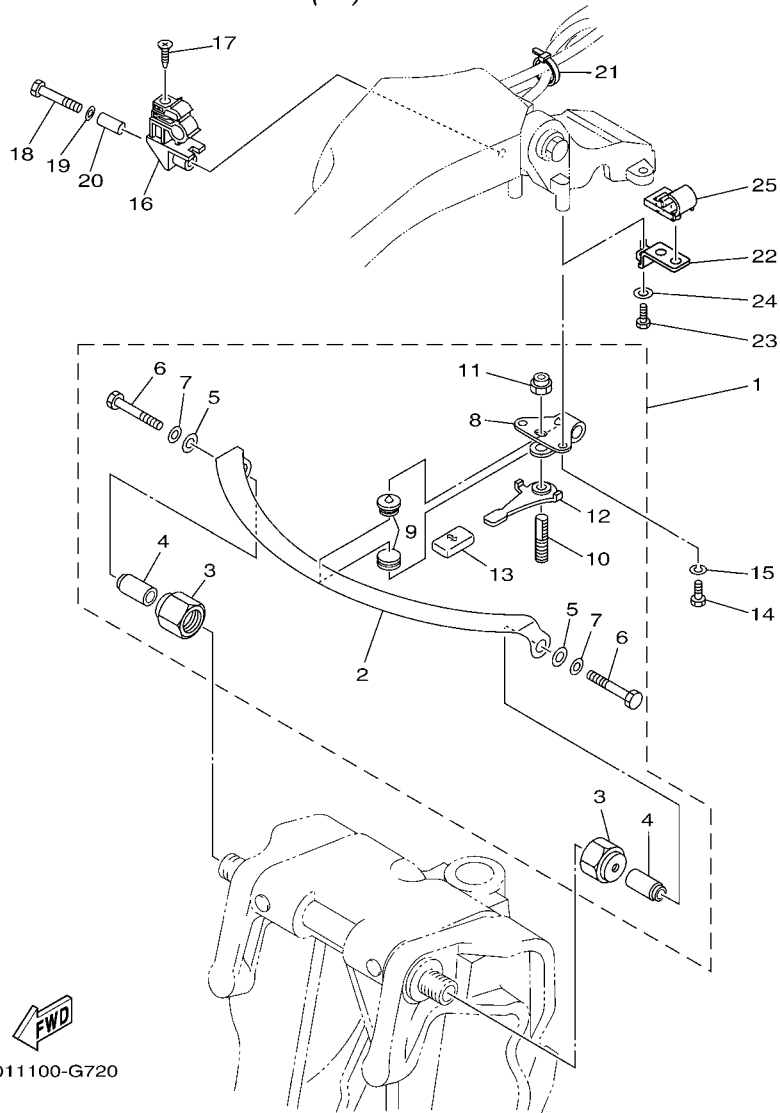

6011100-G720

FIG. 12 STEERING FRICTION 4

REF. NO.	PART NO.	DESCRIPTION	QTY	REMARKS
1	63D-42508-00	STEERING FRICTION ASSY	1	
2	63D-42527-00	.PLATE, FRICTION	1	
3	63D-42546-00	.NUT	2	
4	63D-42541-00	.PIPE 1	2	
5	90201-08M01	.WASHER, PLATE	2	
6	97095-08050	.BOLT	2	
7	92990-08600	.WASHER, PLATE	2	
8	63D-42526-00	.PLATE, FRICTION	1	
9	63D-42528-00	.PLATE, FRICTION	2	
10	63D-42562-00	.SHAFT, STEERING LOCK	1	
11	90185-10M01	.NUT, SELF-LOCKING	1	
12	63D-42561-00	.KNOB, STEERING LOCK	1	
13	682-43318-01	.COVER	1	
14	97095-06016	BOLT	2	
15	92995-06100	WASHER, SPRING	2	
16	63D-82361-00	CLAMP, CORD	1	
17	90161-06M00	SCREW, TAPPING	1	
18	97095-06035	BOLT	1	
19	92995-06600	WASHER	1	
20	90387-06M26	COLLAR	1	
21	90465-13M36	CLAMP	1	
22	63D-24364-10	STAY	1	
23	97095-06016	BOLT	1	
24	92995-06600	WASHER	1	
25	63D-24367-00	CLAMP, FUEL PIPE 2	1	



6X4 TILLER HANDLE FITTING KIT  
STEERING FRICTION (F40-FI)

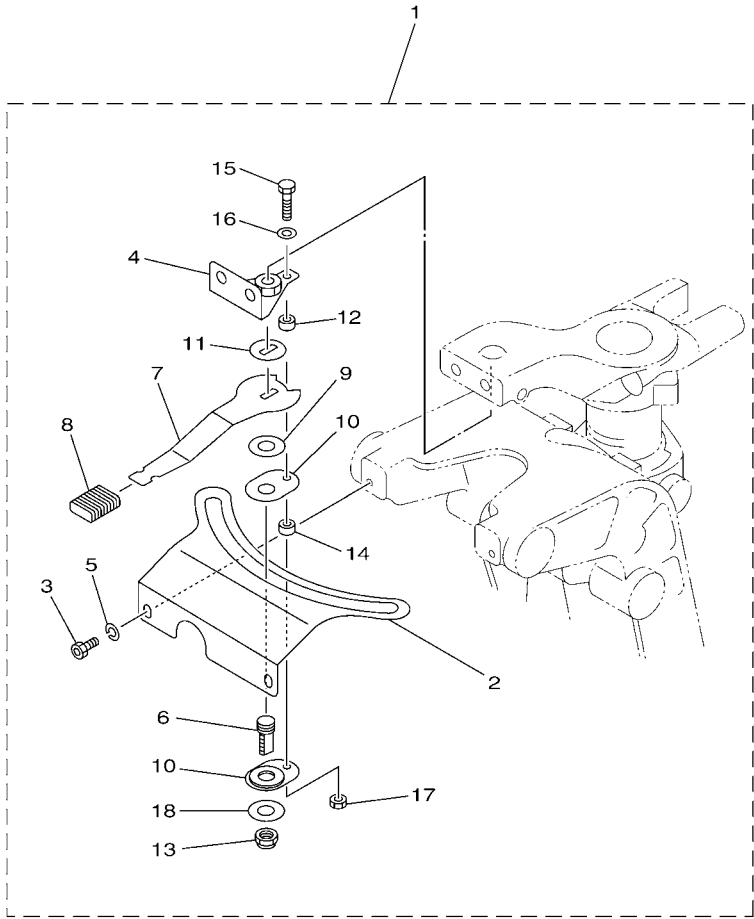

601S10S-L140

FIG. 14 STEERING FRICTION 5

REF. NO.	PART NO.	DESCRIPTION	601S				REMARKS
1	67C-42508-04	STEERING FRICTION ASSY	1				
2	67C-42527-03	.PLATE, FRICTION	1				
3	90109-06M88	.BOLT	2				
4	67C-42525-00	.PLATE, FRICTION	1				
5	92990-06100	.WASHER, SPRING	2				
6	67C-42562-00	.SHAFT, STEERING LOCK	1				
7	67C-42561-00	.KNOB, STEERING LOCK	1				
8	689-43633-00	.COVER, TILT LEVER	1				
9	90202-10M56	.WASHER, PLATE	1				
10	65W-42528-00	.PLATE, FRICTION	2				
11	90209-10M26	.WASHER	1				
12	90387-05053	.COLLAR	1				
13	90185-10M14	.NUT, SELF-LOCKING	1				
14	90387-05054	.COLLAR	1				
15	97095-05020	.BOLT	1				
16	92995-05600	.WASHER	1				
17	95380-05600	.NUT	1				
18	90201-106M5	.WASHER, PLATE	1				

### STEERING FRICTION

Part No.	Applicable model
6AH-42508-01	F9.9F(F9.9A), F9.9H, FT9.9G(T9.9A), F15C (F15A), F20B (F20A), F20C MT
6AH-42508-11	FT9.9G(T9.9A), F15C (F15A), F20B (F20A) PT

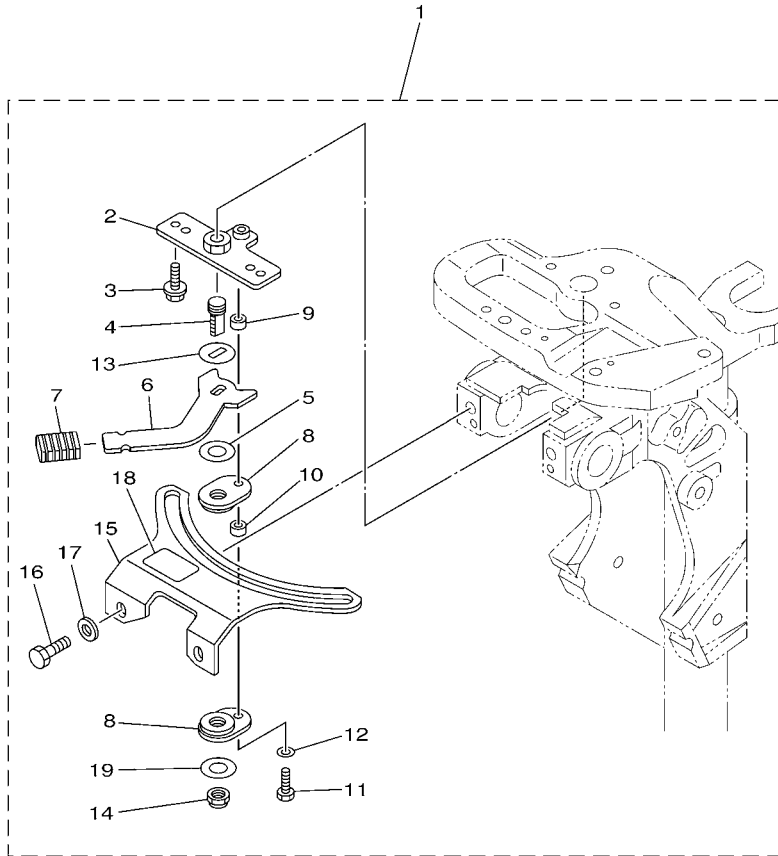

601S10S-L150

FIG. 15 STEERING FRICTION 6

REF. NO.	PART NO.	DESCRIPTION	601S				REMARKS
1	6AH-42508-01	STEERING FRICTION ASSY	1				UR
	6AH-42508-11	STEERING FRICTION ASSY	1				UR
2	68T-42525-01	.PLATE, FRICTION	1				
3	90119-05018	.BOLT, WITH WASHER	2				
4	67C-42562-00	.SHAFT, STEERING LOCK	1				
5	90202-10M56	.WASHER, PLATE	1				
6	68T-42561-00	.KNOB, STEERING LOCK	1				
7	689-43633-00	.COVER, TILT LEVER	1				
8	65W-42528-00	.PLATE, FRICTION	2				
9	90387-05053	.COLLAR	1				
10	90387-05054	.COLLAR	1				
11	97095-05020	.BOLT	1				
12	92995-05600	.WASHER	1				
13	90209-10M26	.WASHER	1				
14	90185-10M14	.NUT, SELF-LOCKING	1				
15	6AH-42527-00	.PLATE, FRICTION	1				
16	90101-08022	.BOLT	2				
17	90201-08065	.WASHER, PLATE	2				
18	68T-43155-00	.MARK 1	1				FOR 6AH-42508-01
19	90201-106M5	.WASHER, PLATE	1				

### STEERING FRICTION

Part No.	Applicable model
65W-42508-00	F25D (F25A), (E)40X

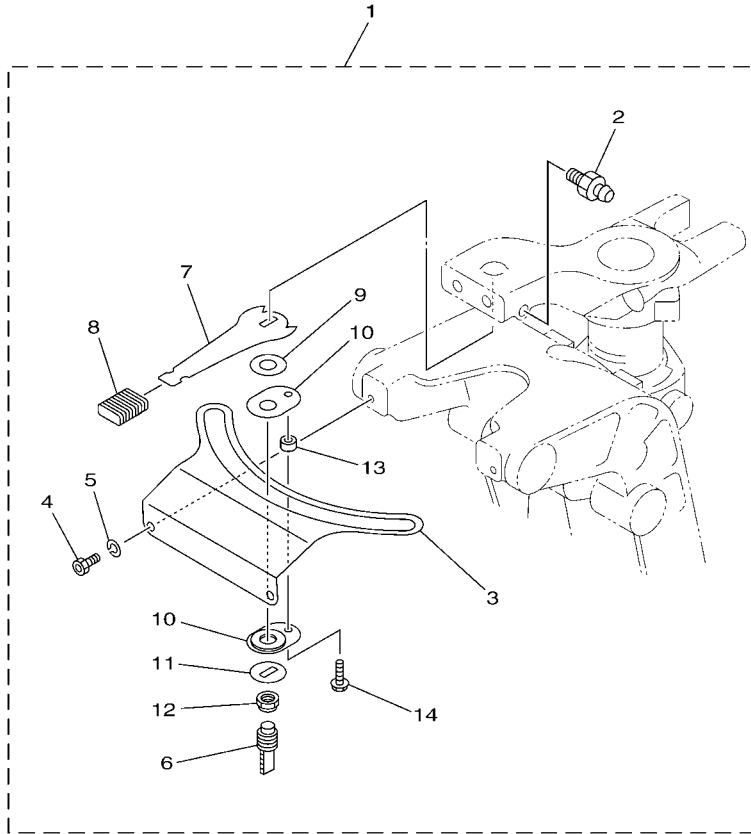

601S10S-L160

FIG. 16 STEERING FRICTION 7

REF. NO.	PART NO.	DESCRIPTION	601S				REMARKS
1	65W-42508-00	STEERING FRICTION ASSY	1				
2	93700-06M03	.NIPPLE, GREASE	1				
3	65W-42527-00	.PLATE, FRICTION	1				
4	90109-06M88	.BOLT	2				
5	92990-06100	.WASHER, SPRING	2				
6	65W-42562-00	.SHAFT, STEERING LOCK	1				
7	65W-42561-00	.KNOB, STEERING LOCK	1				
8	689-43633-00	.COVER, TILT LEVER	1				
9	90202-10M56	.WASHER, PLATE	1				
10	65W-42528-00	.PLATE, FRICTION	2				
11	90209-10M26	.WASHER	1				
12	90185-10M14	.NUT, SELF-LOCKING	1				
13	90387-05054	.COLLAR	1				
14	90109-05M89	.BOLT	1				

### STEERING FRICTION

Part No.	Applicable model
67C-42508-04	F30B (F30A), F40F (F40A)

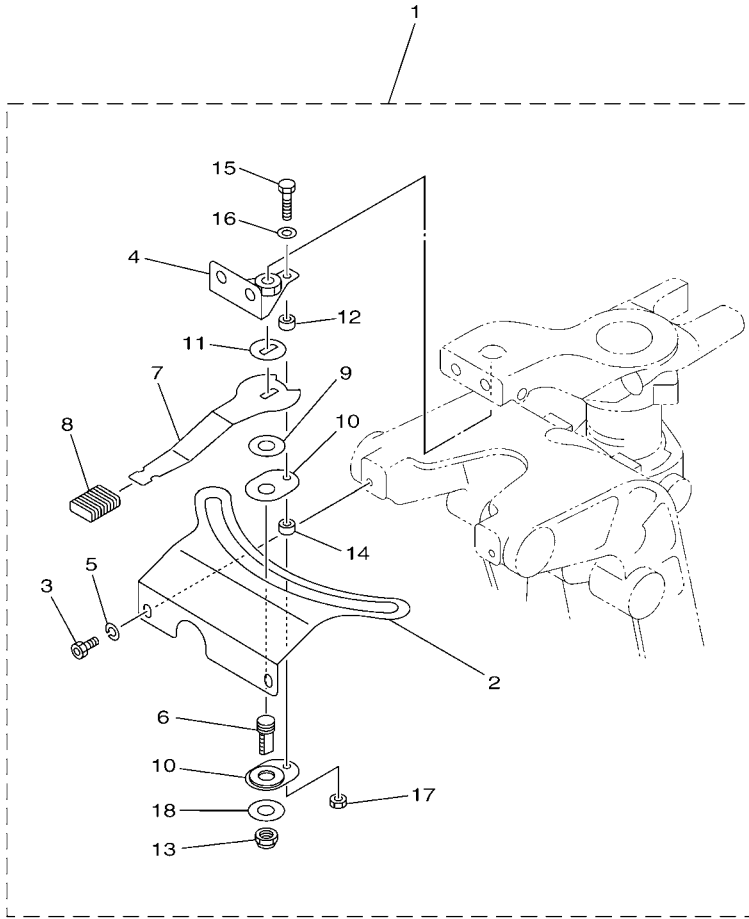

601S10S-L170

FIG. 17 STEERING FRICTION 8

REF. NO.	PART NO.	DESCRIPTION	601S				REMARKS
1	67C-42508-04	STEERING FRICTION ASSY	1				
2	67C-42527-03	.PLATE, FRICTION	1				
3	90109-06M88	.BOLT	2				
4	67C-42525-00	.PLATE, FRICTION	1				
5	92990-06100	.WASHER, SPRING	2				
6	67C-42562-00	.SHAFT, STEERING LOCK	1				
7	67C-42561-00	.KNOB, STEERING LOCK	1				
8	689-43633-00	.COVER, TILT LEVER	1				
9	90202-10M56	.WASHER, PLATE	1				
10	65W-42528-00	.PLATE, FRICTION	2				
11	90209-10M26	.WASHER	1				
12	90387-05053	.COLLAR	1				
13	90185-10M14	.NUT, SELF-LOCKING	1				
14	90387-05054	.COLLAR	1				
15	97095-05020	.BOLT	1				
16	92995-05600	.WASHER	1				
17	95380-05600	.NUT	1				
18	90201-106M5	.WASHER, PLATE	1				



# STEERING FRICTION

Part No.	Applicable model
63D-42508-00	FT50C, F50D, 40V, 50H (50)

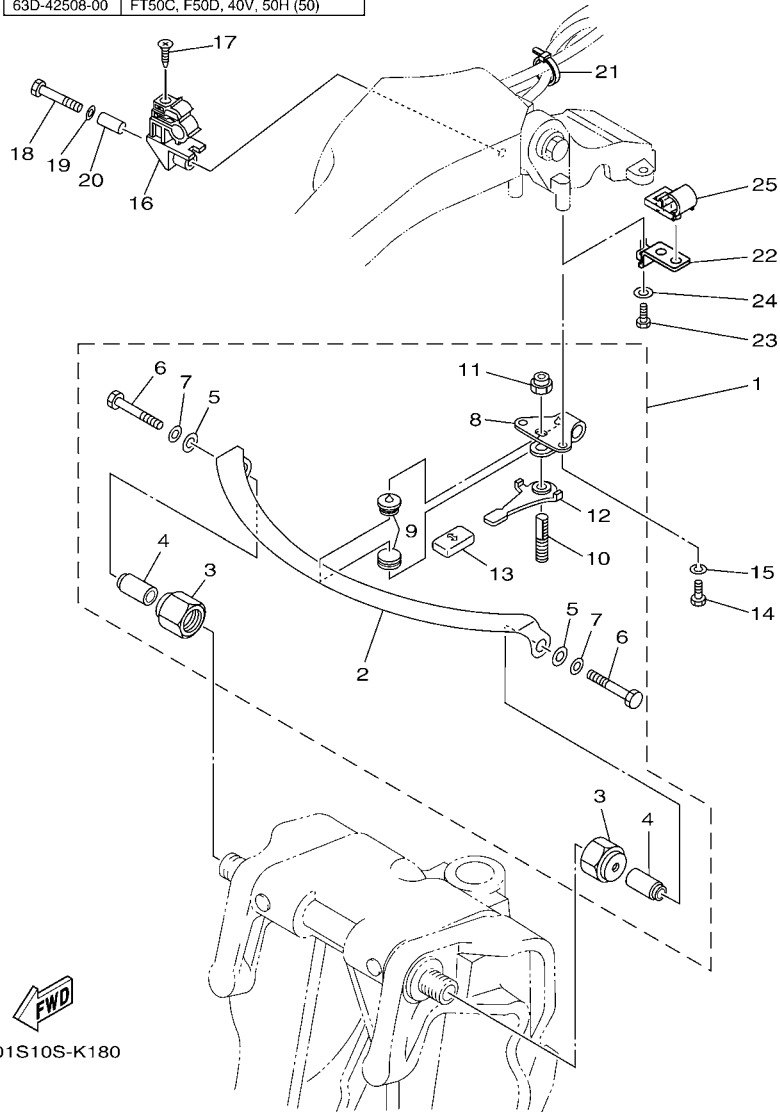

601S10S-K180

FIG. 18 STEERING FRICTION 9

REF. NO.	PART NO.	DESCRIPTION	601S				REMARKS
1	63D-42508-00	STEERING FRICTION ASSY	1				
2	63D-42527-00	.PLATE, FRICTION	1				
3	63D-42546-00	.NUT	2				
4	63D-42541-00	.PIPE 1	2				
5	90201-08M01	.WASHER, PLATE	2				
6	97095-08050	.BOLT	2				
7	92990-08600	.WASHER, PLATE	2				
8	63D-42526-00	.PLATE, FRICTION	1				
9	63D-42528-00	.PLATE, FRICTION	2				
10	63D-42562-00	.SHAFT, STEERING LOCK	1				
11	90185-10M01	.NUT, SELF-LOCKING	1				
12	63D-42561-00	.KNOB, STEERING LOCK	1				
13	682-43318-01	.COVER	1				
14	97095-06016	BOLT	2				
15	92995-06100	WASHER, SPRING	2				
16	63D-82361-00	CLAMP, CORD	1				
17	90161-06M00	SCREW, TAPPING	1				
18	97095-06035	BOLT	1				
19	92995-06600	WASHER	1				
20	90387-06M26	COLLAR	1				
21	90465-13M36	CLAMP	1				
22	63D-24364-10	STAY	1				
23	97095-06016	BOLT	1				
24	92995-06600	WASHER	1				
25	63D-24367-00	CLAMP, FUEL PIPE 2	1				



# STEERING FRICTION

Part No.	Applicable model
6C5-42508-01	F50F (F50A), FT50G (T50A), F60C (F60A), FT60D (T60A), F40D, F70A (F70A)

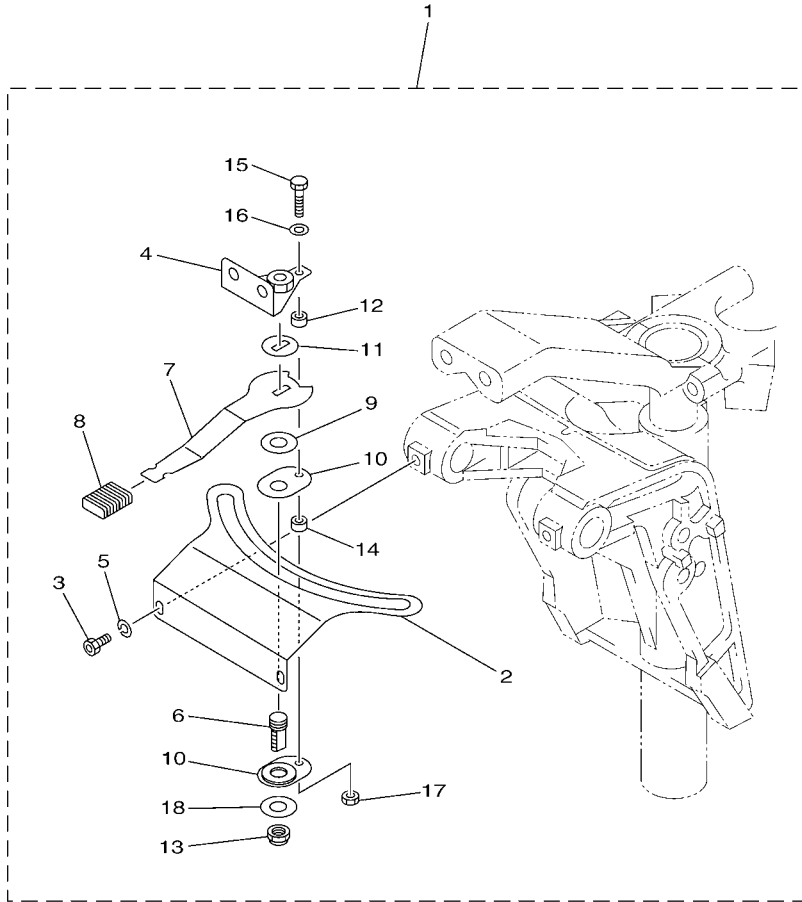

601S10S-L200

FIG. 20 STEERING FRICTION 11

REF. NO.	PART NO.	DESCRIPTION	601S				REMARKS
1	6C5-42508-01	STEERING FRICTION ASSY	1				
2	6C5-42527-00	.PLATE, FRICTION	1				
3	90109-06M88	.BOLT	2				
4	67C-42525-00	.PLATE, FRICTION	1				
5	92990-06100	.WASHER, SPRING	2				
6	67C-42562-00	.SHAFT, STEERING LOCK	1				
7	67C-42561-00	.KNOB, STEERING LOCK	1				
8	689-43633-00	.COVER, TILT LEVER	1				
9	90202-10M56	.WASHER, PLATE	1				
10	65W-42528-00	.PLATE, FRICTION	2				
11	90209-10M26	.WASHER	1				
12	90387-05053	.COLLAR	1				
13	90185-10M14	.NUT, SELF-LOCKING	1				
14	90387-05054	.COLLAR	1				
15	97095-05020	.BOLT	1				
16	92995-05600	.WASHER	1				
17	95380-05600	.NUT	1				
18	90201-106M5	.WASHER, PLATE	1				

# STEERING FRICTION

Part No.	Applicable model
67G-42508-10	F75B (F75A), F80B, F90B (F90A), F95A, F100D, F100B, F115A (F115A), F75C, F80C

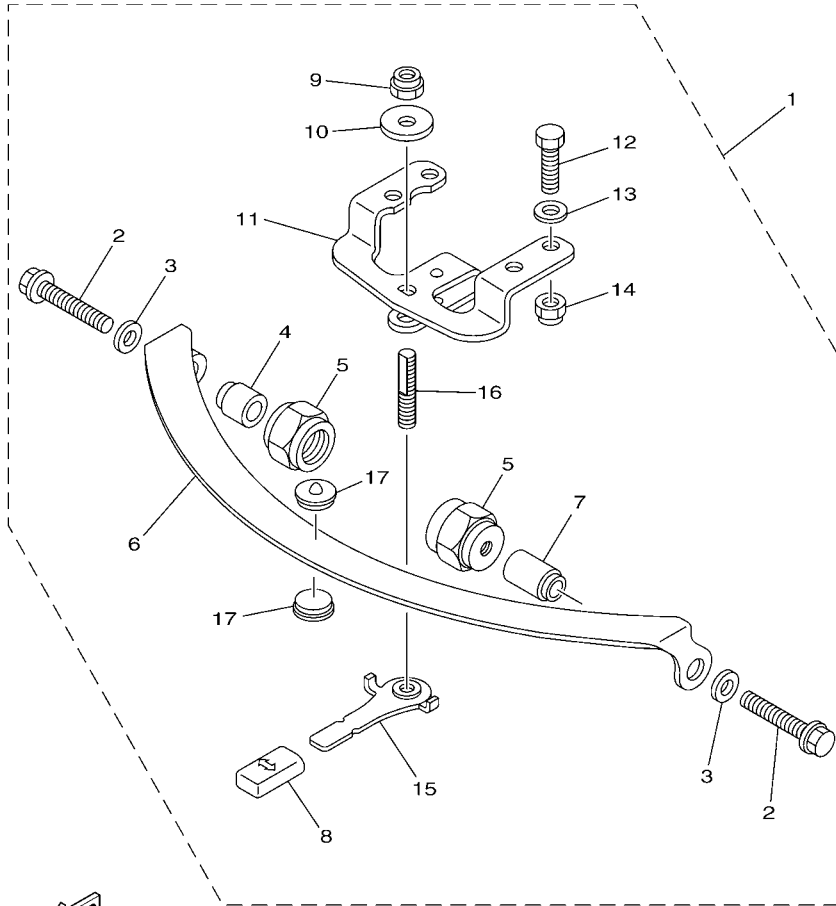

601S10S-L210

FIG. 21 STEERING FRICTION 12

REF. NO.	PART NO.	DESCRIPTION	601S				REMARKS
1	67G-42508-10	STEERING FRICTION ASSY	1				
2	90119-08M74	.BOLT, WITH WASHER	2				
3	90201-08M01	.WASHER, PLATE	2				
4	67G-42541-00	.PIPE 1	1				
5	67G-42546-00	.NUT	2				
6	63D-42527-00	.PLATE, FRICTION	1				
7	67G-42541-10	.PIPE 1	1				
8	682-43318-01	.COVER	1				
9	90185-10M14	.NUT, SELF-LOCKING	1				
10	90201-10M76	.WASHER, PLATE	1				
11	6X4-42526-00	.PLATE, FRICTION	1				
12	97095-08025	.BOLT	2				
13	92995-08600	.WASHER	2				
14	90185-08057	.NUT, SELF-LOCKING	2				
15	67G-42561-00	.KNOB, STEERING LOCK	1				
16	67G-42562-00	.SHAFT, STEERING LOCK	1				
17	63D-42528-00	.PLATE, FRICTION	2				

### STEERING FRICTION

Part No.	Applicable model
68T-42508-02	F8C (F8A), FT8D(T8A)

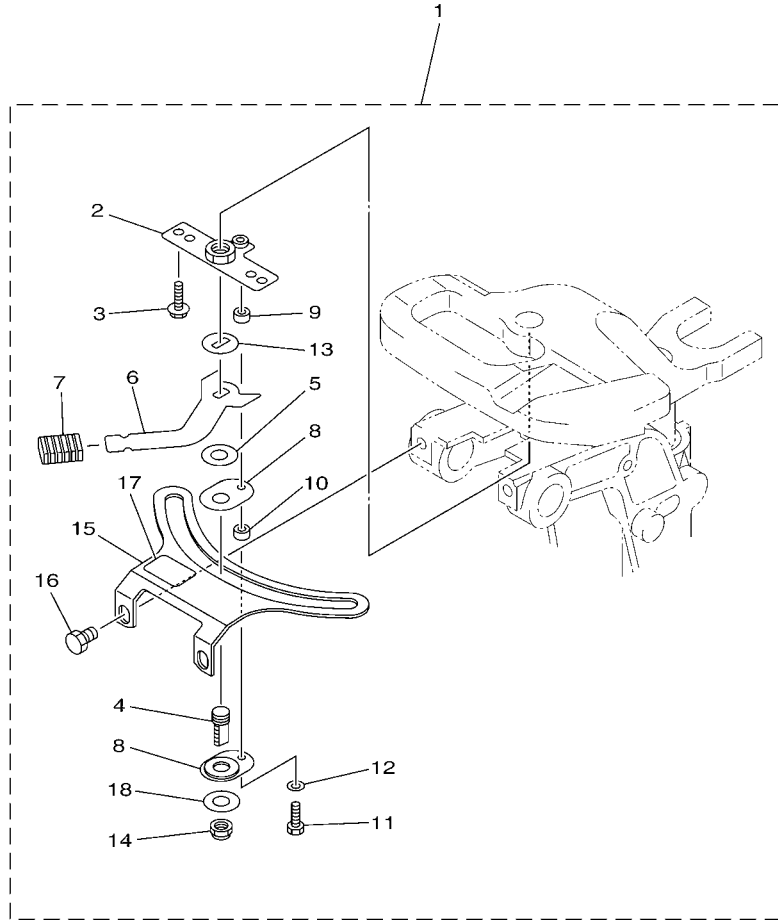

601S10S-L220

FIG. 22 STEERING FRICTION 13

REF. NO.	PART NO.	DESCRIPTION	601S				REMARKS
1	68T-42508-02	STEERING FRICTION ASSY	1				
2	68T-42525-01	.PLATE, FRICTION	1				
3	97595-05514	.BOLT, WITH WASHER	2				
4	67C-42562-00	.SHAFT, STEERING LOCK	1				
5	90202-10M56	.WASHER, PLATE	1				
6	68T-42561-00	.KNOB, STEERING LOCK	1				
7	689-43633-00	.COVER, TILT LEVER	1				
8	65W-42528-00	.PLATE, FRICTION	2				
9	90387-05053	.COLLAR	1				
10	90387-05054	.COLLAR	1				
11	97095-05020	.BOLT	1				
12	92995-05600	.WASHER	1				
13	90209-10M26	.WASHER	1				
14	90185-10M14	.NUT, SELF-LOCKING	1				
15	68T-42527-01	.PLATE, FRICTION	1				
16	90109-08M91	.BOLT	2				
17	68T-43155-00	.MARK 1	1				
18	90201-106M5	.WASHER, PLATE	1				

NUMERICAL INDEX

PART NO.	REF. NO.	PART NO.	REF. NO.	PART NO.	REF. NO.	PART NO.	REF. NO.	PART NO.	REF. NO.	PART NO.	REF. NO.
6X4-14137-00	1 - 26	6C5-42508-01	20 - 1	67G-42541-00	21 - 4	689-43633-00	17 - 8	6X4-82510-00	2 - 1	90185-10051	9 - 5
6X4-24364-00	3 - 18	68T-42508-02	22 - 1	67G-42541-10	5 - 7		20 - 8	703-82532-00	2 - 3		11 - 3
	4 - 19	67C-42508-04	14 - 1		21 - 7		22 - 7	6X4-82540-00	1 - 28		13 - 2
63D-24364-10	12 - 22		17 - 1	63D-42546-00	12 - 3	6X4-44100-00	1 - 21	682-82556-00	2 - 6	90185-10M01	12 - 11
	18 - 22	67G-42508-10	5 - 1		18 - 3	6X4-44102-00	1 - 23	6X4-82563-00	2 - 8		18 - 11
63D-24367-00	3 - 17		21 - 1	67G-42546-00	5 - 5	6X4-44132-00	1 - 25	69W-82575-00	2 - 5	90185-10M14	5 - 9
	4 - 18	6AH-42508-11	15 - 1		21 - 5	6X4-44139-01	1 - 9	676-82577-00	2 - 2		7 - 13
	12 - 25	692-42515-01	10 - 6	63D-42561-00	12 - 12	6X4-44159-00-8D	1 - 42	689-8257Y-00	2 - 7		14 - 13
	18 - 25		19 - 6		18 - 12	6X4-44159-10-8D	8 - 12	6X4-82586-00	11 - 11		15 - 14
69W-26301-00	6 - 6	663-42518-00	10 - 2	65W-42561-00	16 - 7	6X4-44173-00	1 - 43	6X4-82586-10	6 - 10		16 - 12
	13 - 6		19 - 2	67C-42561-00	7 - 7		8 - 13		13 - 10		17 - 13
63D-26301-01	11 - 7	67C-42525-00	7 - 4		14 - 7	6X4-44177-00	1 - 12	6X4-82586-20	3 - 13		20 - 13
6H1-26301-01	8 - 7		14 - 4		17 - 7	6X4-44188-00	1 - 15		4 - 13		21 - 9
6H3-26301-01	9 - 9		17 - 4		20 - 7	6G8-44191-00	1 - 45	6X4-82586-30	8 - 11		22 - 14
67G-26301-10	3 - 9		20 - 4	67G-42561-00	5 - 15	6X4-47731-00	1 - 24		9 - 13	90185-12M12	1 - 58
	4 - 9	68T-42525-01	15 - 2		21 - 15	6A5-48129-10	1 - 29	6X4-83383-00	2 - 10	90201-08065	15 - 17
6X4-26367-00	1 - 36		22 - 2	68T-42561-00	15 - 6	6X4-48154-00	1 - 18	6X4-83386-00	2 - 11	90201-08M01	5 - 3
	1 - 39	63D-42526-00	12 - 8		22 - 6	6X4-48215-00	1 - 4	6G5-83557-00	3 - 15		12 - 5
6X4-41291-00	1 - 8		18 - 8	63D-42562-00	12 - 10	6X4-48261-00	1 - 27	6K3-83557-00	4 - 16		18 - 5
6X4-42102-00	3 - 1	6X4-42526-00	5 - 11		18 - 10	63D-48321-11	11 - 4	90101-08022	15 - 16		21 - 3
6X4-42102-10	4 - 1		21 - 11	65W-42562-00	16 - 6	67C-48321-11	6 - 3	90101-12014	1 - 51	90201-106M5	7 - 18
6X4-42102-22	6 - 1	63D-42527-00	5 - 6	67C-42562-00	7 - 6		13 - 3	90109-05M89	16 - 14		14 - 18
6X4-42102-41	8 - 1		12 - 2		14 - 6	6H1-48321-11	8 - 4	90109-06M88	7 - 3		15 - 19
6X4-42102-51	9 - 1		18 - 2		15 - 4	6H3-48321-11	9 - 6		14 - 3		17 - 18
6X4-42102-61	11 - 1		21 - 6		17 - 6	67G-48321-20	3 - 6		16 - 4		20 - 18
6X4-42102-70	13 - 1	65W-42527-00	16 - 3		20 - 6		4 - 6		17 - 3		22 - 18
6X4-42103-50	1 - 1	6AH-42527-00	15 - 15		22 - 4	63D-48538-00	3 - 7		20 - 3	90201-10M76	5 - 10
6X4-42111-02-8D	1 - 2	6C5-42527-00	7 - 2	67G-42562-00	5 - 16		3 - 10	90109-08M91	22 - 16		21 - 10
6X4-42115-00	1 - 22		20 - 2		21 - 16		4 - 7	90116-10031	4 - 5	90201-12035	1 - 55
6X4-42119-01	1 - 5	68T-42527-01	22 - 15	6H4-42724-20	11 - 2		4 - 10		8 - 3	90202-10M56	7 - 9
6X4-42121-00-8D	4 - 3	67C-42527-03	14 - 2	6X4-42725-01	1 - 49		6 - 4		9 - 4		14 - 9
	8 - 2		17 - 2	68V-42725-10	3 - 2		6 - 7	90116-10175	3 - 4		15 - 5
	9 - 3	63D-42528-00	5 - 17		4 - 2		8 - 5	90119-05018	15 - 3		16 - 9
6X4-42121-11-8D	3 - 3		12 - 9	6H3-42725-30	9 - 2		8 - 8	90119-08M74	5 - 2		17 - 9
63D-42121-22-8D	1 - 50		18 - 9	6X4-42728-10	1 - 59		9 - 7		21 - 2		20 - 9
63D-42126-00	1 - 17		21 - 17	6X4-42735-00	3 - 16		9 - 10	90152-05007	1 - 10		22 - 5
6X4-42128-00	1 - 13	65W-42528-00	7 - 10		4 - 17		11 - 5	90161-06M00	12 - 17	90206-12M22	1 - 53
6X4-42131-01	1 - 47		14 - 10	6X4-42821-00	1 - 30		11 - 8		18 - 17	90209-10M26	7 - 11
6X4-42137-00	1 - 7		15 - 8	68T-43155-00	15 - 18		13 - 4	90175-06003	10 - 5		14 - 11
6X4-42159-00	1 - 41		16 - 10		22 - 17		13 - 7		19 - 5		15 - 13
6X4-42177-00	1 - 6		17 - 10	682-43318-01	5 - 8	6X4-48538-00	1 - 35	90185-08057	5 - 14		16 - 11
63D-42508-00	12 - 1		20 - 10		12 - 13	6X4-48538-10	1 - 38		10 - 8		17 - 11
	18 - 1		22 - 8		18 - 13	6X4-81860-00	4 - 14		19 - 8		20 - 11
65W-42508-00	16 - 1	663-42528-00	10 - 3		21 - 8		6 - 11		21 - 14		22 - 13
692-42508-01	10 - 1		19 - 3	689-43633-00	7 - 8		13 - 11	90185-10051	3 - 5	90386-08032	1 - 16
	19 - 1	63D-42541-00	12 - 4		14 - 8	6X4-81942-01	2 - 13		4 - 4	90386-12003	1 - 56
6AH-42508-01	15 - 1		18 - 4		15 - 7	63D-82361-00	12 - 16		6 - 2	90386-26MA3	1 - 46
6C5-42508-01	7 - 1	67G-42541-00	5 - 4		16 - 8		18 - 16		8 - 19		8 - 15

NUMERICAL INDEX

PART NO.	REF. NO.	PART NO.	REF. NO.	PART NO.	REF. NO.	PART NO.	REF. NO.	PART NO.	REF. NO.	PART NO.	REF. NO.
90387-05053	7 - 12	90468-10005	13 - 5	97095-05020	20 - 15						
	14 - 12		13 - 8		22 - 11						
	15 - 9	90501-23215	1 - 14	97095-06014	1 - 37						
	17 - 12	91490-20010	1 - 11		1 - 40						
	20 - 12		1 - 20		2 - 12						
	22 - 9	92990-06100	7 - 5	97095-06016	3 - 19						
90387-05054	7 - 14		14 - 5		4 - 20						
	14 - 14		16 - 5		12 - 14						
	15 - 10		17 - 5		12 - 23						
	16 - 13		20 - 5		18 - 14						
	17 - 14	92990-08600	10 - 7		18 - 23						
	20 - 14		12 - 7	97095-06030	1 - 33						
	22 - 10		18 - 7	97095-06035	12 - 18						
90387-06M26	12 - 20		19 - 7		18 - 18						
	18 - 20	92990-12200	1 - 52	97095-08025	5 - 12						
90387-12M02	1 - 54	92990-12600	1 - 57		21 - 12						
90447-22007	3 - 14	92995-05600	7 - 16	97095-08040	1 - 31						
	4 - 15		14 - 16		8 - 16						
90464-08M07	2 - 4		15 - 12	97095-08050	12 - 6						
90464-09M42	3 - 12		17 - 16		18 - 6						
	4 - 12		20 - 16	97595-05514	22 - 3						
	6 - 9		22 - 12	97780-60920	1 - 44						
	8 - 10	92995-06100	12 - 15		8 - 14						
	9 - 12		18 - 15	97980-06216	2 - 9						
	11 - 10	92995-06600	1 - 34	97985-06216	1 - 48						
	13 - 9		3 - 20								
90465-13M24	3 - 21		4 - 21								
	4 - 22		12 - 19								
90465-13M30	3 - 22		12 - 24								
	4 - 23		18 - 19								
90465-13M36	6 - 12		18 - 24								
	8 - 18	92995-08600	1 - 32								
	9 - 14		5 - 13								
	12 - 21		8 - 17								
	13 - 12		21 - 13								
	18 - 21	93700-06M03	1 - 3								
90468-10005	3 - 8		16 - 2								
	3 - 11	95380-05600	7 - 17								
	4 - 8		14 - 17								
	4 - 11		17 - 17								
	6 - 5		20 - 17								
	6 - 8	95380-06600	1 - 19								
	8 - 6	97080-06035	10 - 4								
	8 - 9		19 - 4								
	9 - 8	97095-05020	7 - 15								
	9 - 11		14 - 15								
	11 - 6		15 - 11								
	11 - 9		17 - 15								