



PARTS CATALOGUE

RIGGING-STEERING



1K601-10SE1

()

RIGGING-STEERING
PARTS CATALOGUE

©2011 by Yamaha Motor Co., Ltd.
1st edition, November 2011

All rights reserved.

Any reprinting or unauthorized use
without the written permission of
Yamaha Motor Co., Ltd.
is expressly prohibited.

Printed in Japan.

FOREWORD

This Parts Catalogue is related to the parts for the model(s) on the cover page. When you are ordering replacement parts, please refer to this Parts Catalogue and quote both part numbers and part names correctly.

1. Modifications or additions which have been made after the issue of the Parts Catalogue will be announced in the Parts News.

It is advisable that you make the necessary corrections to the Parts Catalogue according to the Parts News.

2. Abbreviations

The following abbreviations are used in this Parts Catalogue.

“UR” Use specified parts number.

“UN” Use as many as needed.

“AP” Alternate Parts

“LM” Locally Made (Parts need to be ordered locally)

“F#” Frame No. (Applicable machine No.)

“O/S” Over Size

3. The number of components for assembly

- Parts, which are to be supplied in an assembly, are listed with a dot (.) in front of the part name as shown below.
- The numeral appearing to the right of each component part indicates the quantity of parts for each assembly unit.

PART NO.	DESCRIPTION	Q'TY	REMARKS
2F5-83310-60	FRONT FLASHER LIGHT ASSY	2	
115-83311-60	.BULB (6V-18W)	1	

4. Applicable colours of graphics are represented in the “REMARKS” as shown below.

PART NO.	DESCRIPTION	Q'TY	REMARKS
2N4-24110-00-X5	FUEL TANK COMP.	2	MXR
3J1-24240-10	.GRAPHIC, FUEL TANK	1	FOR MXR

5. Note that the illustrations for reference in finding parts numbers are not to be used for assembling. When assembling, please use the applicable service manual.

6. The asterisk (*) before a reference number indicates modified items after the first edition.

CONTENTS

BASE HANDLE - ALL	1
BASE HANDLE ELECTRICAL	4
FITTING KIT 1	5
FITTING KIT 2	6
STEERING FRICTION 1	7
FITTING KIT 3	8
STEERING FRICTION 2	9
FITTING KIT 4	10
FITTING KIT 5	11
STEERING FRICTION 3	12
FITTING KIT 6	13
STEERING FRICTION 4	14
FITTING KIT 7	15
STEERING FRICTION 5	16
STEERING FRICTION 6	17
STEERING FRICTION 7	18
STEERING FRICTION 8	19
STEERING FRICTION 9	20
STEERING FRICTION 10	21
STEERING FRICTION 11	22
STEERING FRICTION 12	23

INDEX

NUMERICAL INDEX	24
-----------------------	----

Application Model

			PART NO. / PART NAME							
			FIG.NO.							
MODEL CODE	MODEL NAME	SERIAL NO.	6X4-42103-50 HANDLE, STEERING	6X4-42102-00 FITTING KIT	6X4-42102-10 FITTING KIT	6X4-42102-22 FITTING KIT	6X4-42102-41 FITTING KIT	6X4-42102-51 FITTING KIT	6X4-42102-61 FITTING KIT	6X4-42102-70 FITTING KIT
			FIG.1, 2	FIG.3, 5	FIG.4, 5	FIG.6, 7	FIG.8, 10	FIG.9, 10	FIG.11, 12	FIG.13, 14
68VA	F115-2011	68V:1113062-	*	*						
6D67	F75-2011	62P:1013273-	*		*					
6D87	F90-2011	61P:1042793-	*		*					
6C17	F50-2011	6C1:1035323-	*			*				
6C57	F60-2011	6C5:1043043-	*			*				
6C27	T50-2011	6C2:1010057-	*			*				
6C67	T60-2011	6C6:1015859-	*			*				
6CJ1	F70-2011	6CJ:1000001-	*			*				
6H1D	90-2011	6H1:1045543-	*				*			
6H3A	70-2011	6H3K:1014635-	*					*		
62XL	50-2011	6H5K:1030659-	*						*	
6BG3	F40(FI)-2011	6BG:1011106-	*							*

6X4 TILLER HANDLE KIT (50-90 & F40-F115)

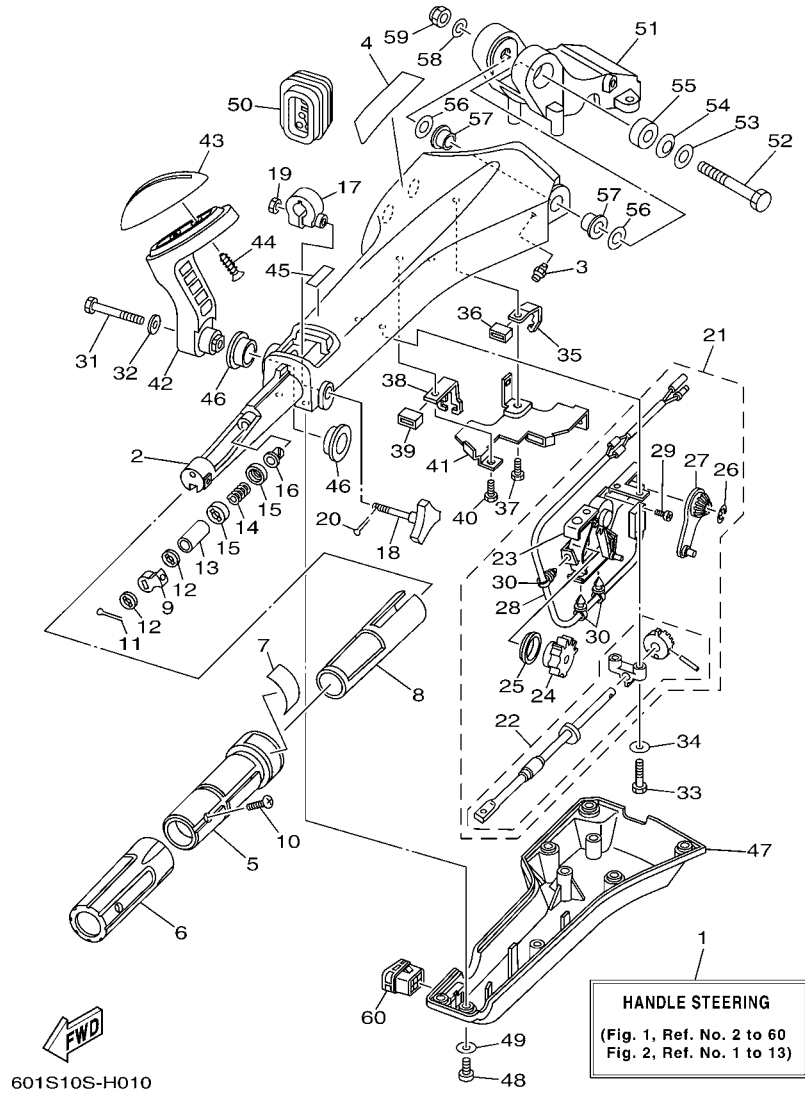

FIG. 1 BASE HANDLE - ALL

REF. NO.	PART NO.	DESCRIPTION	601S				REMARKS
1	6X4-42103-50	TILLER HANDLE KIT	1				LM
2	6X4-42111-02-8D	HANDLE, STEERING	1				
3	93700-06M03	NIPPLE, GREASE	1				
4	6X4-48215-00	GRAPHIC	1				
5	6X4-42119-01	GRIP, STEERING HANDLE	1				
6	6X4-42177-00	RUBBER, HANDLE	1				
7	6X4-42137-00	INDICATOR, THROTTLE	1				
8	6X4-41291-00	BUSHING	1				
9	6X4-44139-01	COLLAR	1				
10	90152-05007	SCREW, COUNTERSUNK	1				
11	91490-20010	PIN. COTTER	1				
12	6X4-44177-00	WASHER	2				
13	6X4-42128-00	COLLAR, DISTANCE 1	1				
14	90501-23215	SPRING, COMPRESSION	1				
15	6X4-44188-00	WASHER	2				
16	90386-08032	BUSH	1				
17	63D-42126-00	FRICION, STEERING HANDLE GRIP	1				
18	6X4-48154-00	KNOB, THROTTLE	1				
19	95380-06600	NUT, HEXAGON	1				
20	91490-20010	PIN. COTTER	1				
21	6X4-44100-00	SHIFT LINK ASSY	1				
22	6X4-42115-00	.SHAFT, STEERING HANDLE	1				
23	6X4-44102-00	.SHIFT ASSIST ASSY.	1				
24	6X4-47731-00	.GEAR, DRIVE	1				
25	6X4-44132-00	.BUSHING	1				
26	6X4-14137-00	.CLIP	1				
27	6X4-48261-00	.ARM, THROTTLE	1				

6X4 TILLER HANDLE KIT (50-90 & F40-F115)

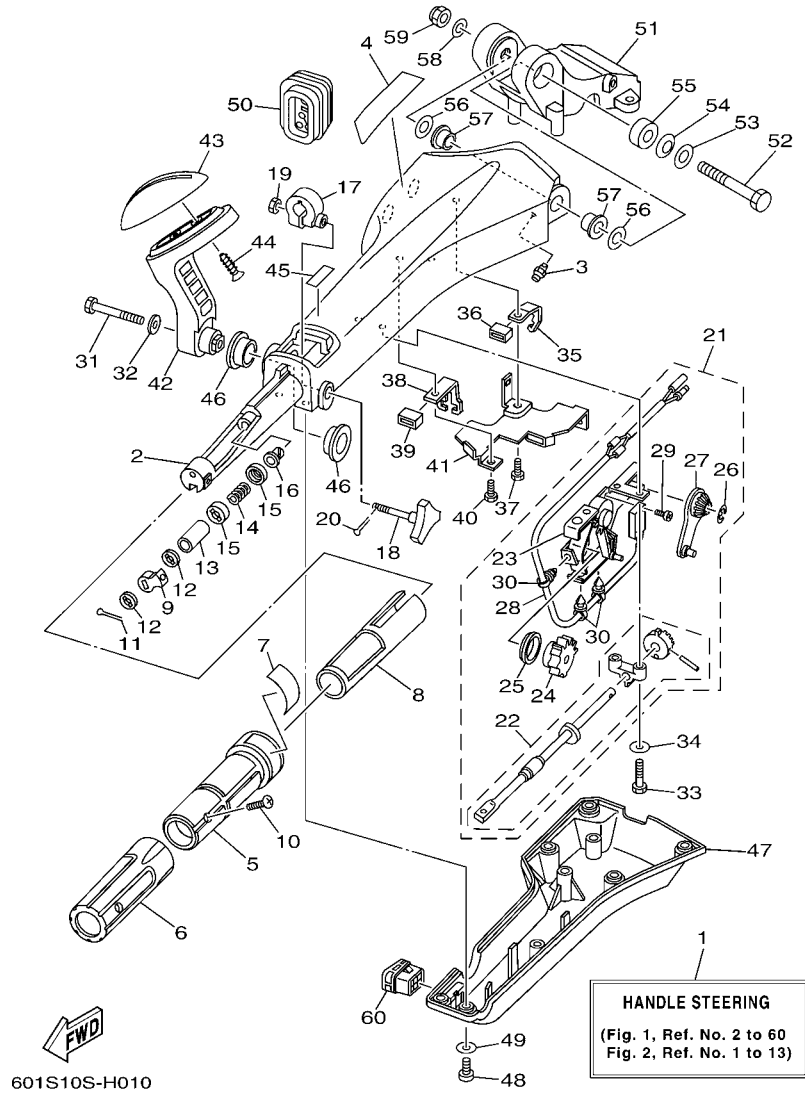
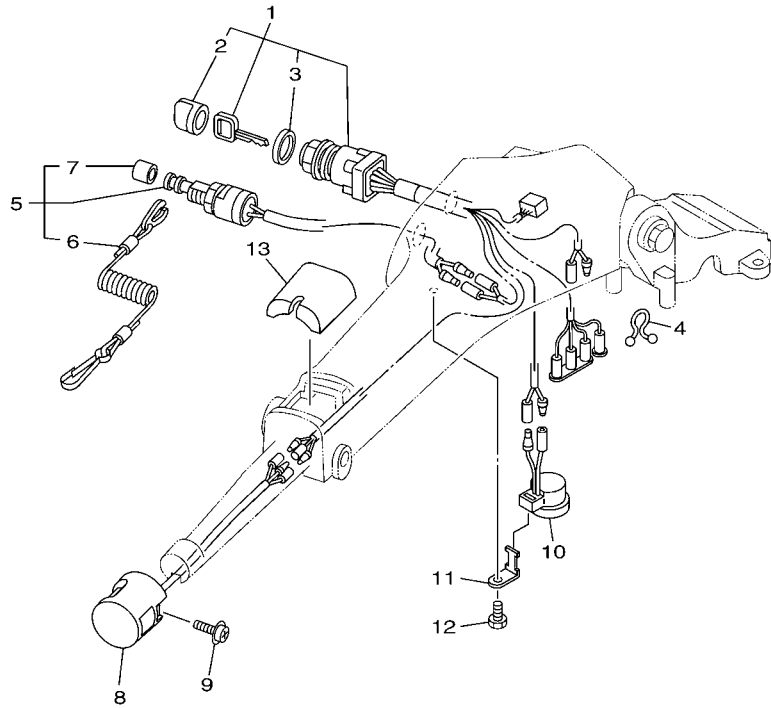

FIG. 1 BASE HANDLE - ALL

REF. NO.	PART NO.	DESCRIPTION	601S				REMARKS
28	6X4-82540-00	.NEUTRAL SWITCH ASSY	1				
29	6A5-48129-10	.SCREW 3	2				
30	6X4-42821-00	.BAND, CLAMP	3				
31	97095-08040	BOLT	1				
32	92995-08600	WASHER	1				
33	97095-06030	BOLT	2				
34	92995-06600	WASHER	2				
35	6X4-48538-00	CLAMP, CABLE 1	1				
36	6X4-26367-00	PROTECTOR	1				
37	97095-06014	BOLT	1				
38	6X4-48538-10	CLAMP, CABLE 1	1				
39	6X4-26367-00	PROTECTOR	1				
40	97095-06014	BOLT	1				
41	6X4-42159-00	STAY	1				
42	6X4-44159-00-8D	HANDLE, GEAR SHIFT	1				
43	6X4-44173-00	LEVER, SHIFT CONTROL	1				
44	97780-60920	SCREW, TAPPING	2				
45	6G8-44191-00	INDICATOR, SHIFT	1				
46	90386-26MA3	BUSH	2				
47	6X4-42131-01	COVER, HANDLE STEERING	1				
48	97885-06016	SCREW, PAN HEAD	6				
49	92995-06600	WASHER	6				
50	6X4-42725-01	GROMMET	1				
51	63D-42121-22-8D	BRACKET	1				
52	90101-12014	BOLT	1				
53	92990-12200	WASHER, PLAIN	1				
54	90206-12M22	WASHER, WAVE	1				

6X4 TILLER HANDLE KIT (50-90 & F40-F115)



601S10S-K020

FIG. 2 BASE HANDLE ELECTRICAL

REF. NO.	PART NO.	DESCRIPTION	601S				REMARKS
1	6X4-82510-00	MAIN SWITCH ASSY	1				
2	676-82577-00	.CAP, KEY	1				
3	703-82532-00	.CAP	1				
4	90464-08M07	CLAMP	1				
5	69W-82575-00	ENGINE STOP SWITCH ASSY	1				
6	682-82556-00	.LANYARD, STOP SWITCH	1				
7	689-8257Y-00	.CAP	1				
8	6X4-82563-00	TRIM & TILT SWITCH ASSY	1				
9	97980-06216	SCREW, WITH WASHER	1				
10	6X4-83383-00	BUZZER	1				
11	6X4-83386-00	STAY, BUZZER	1				
12	97095-06014	BOLT	1				
13	6X4-81942-00	COVER	1				

6X4 TILLER HANDLE FITTING KIT (F115)

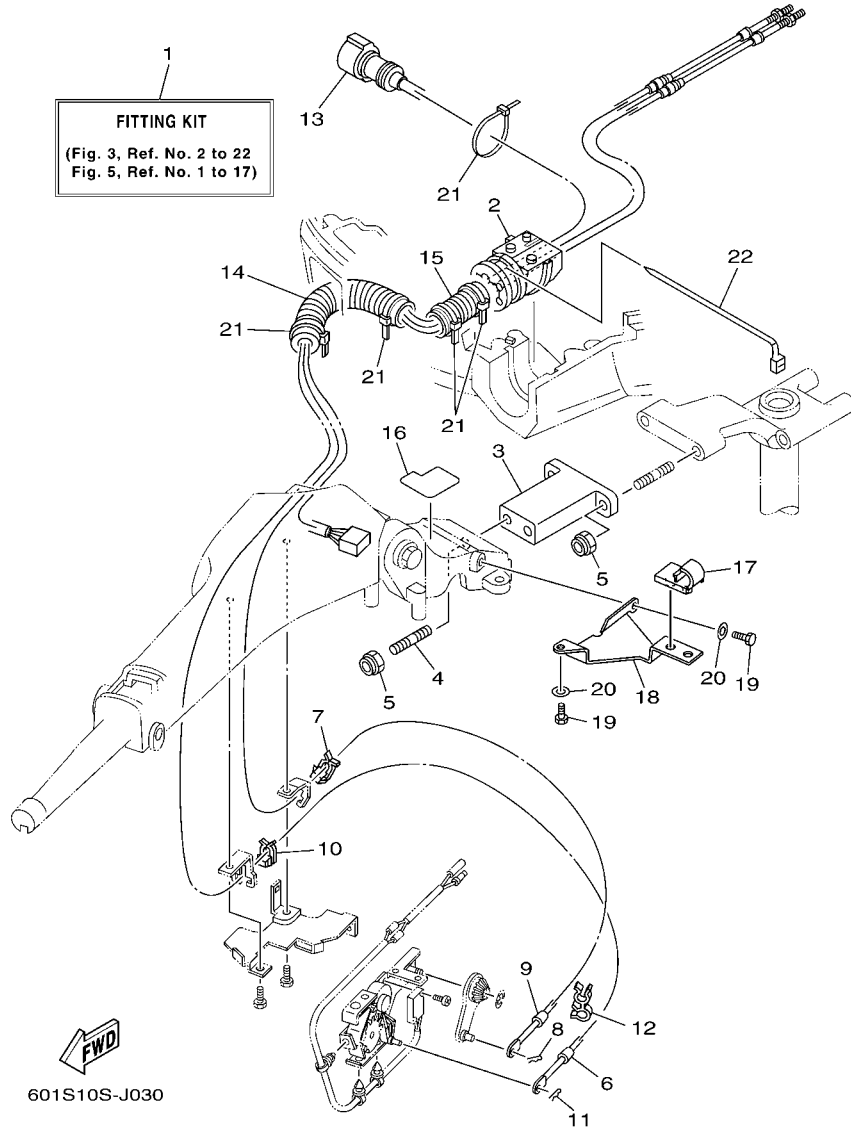

601S10S-J030

FIG. 3 FITTING KIT 1

REF. NO.	PART NO.	DESCRIPTION	601S				REMARKS
1	6X4-42102-00	FITTING KIT	1				LM
2	68V-42725-10	GROMMET	1				
3	6X4-42121-11-8D	BRACKET	1				
4	90116-10175	BOLT, STUD	2				
5	90185-10051	NUT, SELF-LOCKING	4				
6	67G-48321-20	CABLE	1				
7	63D-48538-00	CLAMP, CABLE 1	1				
8	90468-10005	CLIP	1				
9	67G-26301-10	THROTTLE CABLE ASSY	1				
10	63D-48538-00	CLAMP, CABLE 1	1				
11	90468-10005	CLIP	1				
12	90464-09M42	CLAMP	1				
13	6X4-82586-20	EXT., WIRE HARNESS (L:1.25M)	1				
14	90447-22007	TUBE	1				
15	6G5-83557-00	TUBE	1				
16	6X4-42735-00	PROTECTOR	1				
17	63D-24367-00	CLAMP, FUEL PIPE 2	1				
18	6X4-24364-00	STAY	1				
19	97095-06016	BOLT	2				
20	92995-06600	WASHER	2				
21	90465-13M24	CLAMP	5				
22	90465-13M30	CLAMP	1				

6X4 TILLER HANDLE FITTING KIT (F75,F90)

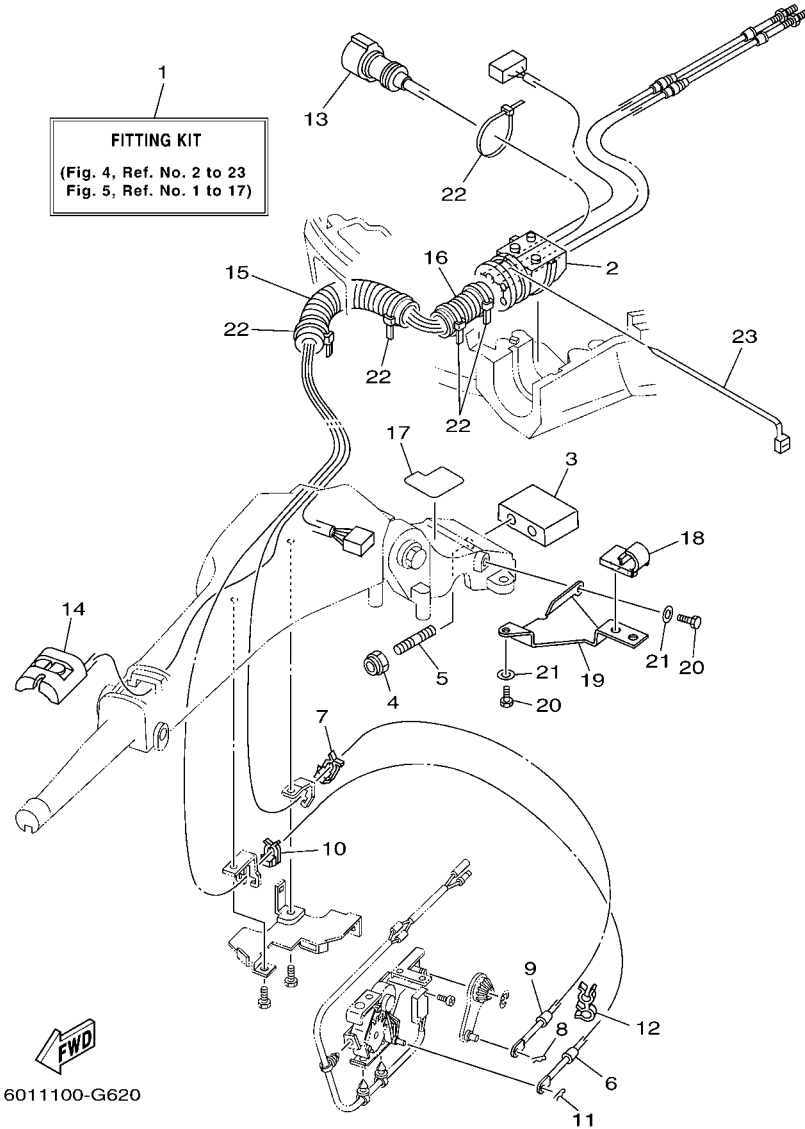

6011100-G620

FIG. 4 FITTING KIT 2

REF. NO.	PART NO.	DESCRIPTION	QTY	REMARKS
1	6X4-42102-10	FITTING KIT	1	LM
2	68V-42725-10	GROMMET	1	
3	6X4-42121-00-8D	BRACKET	1	
4	90185-10051	NUT, SELF-LOCKING	2	
5	90116-10031	BOLT, STUD	2	
6	67G-48321-20	CABLE	1	
7	63D-48538-00	CLAMP, CABLE 1	1	
8	90468-10005	CLIP	1	
9	67G-26301-10	THROTTLE CABLE ASSY	1	
10	63D-48538-00	CLAMP, CABLE 1	1	
11	90468-10005	CLIP	1	
12	90464-09M42	CLAMP	1	
13	6X4-82586-20	EXT., WIRE HARNESS (L:1.25M)	1	
14	6X4-81860-00	SWITCH ASSY	1	
15	90447-22007	TUBE	1	
16	6K3-83557-00	TUBE	1	
17	6X4-42735-00	PROTECTOR	1	
18	63D-24367-00	CLAMP, FUEL PIPE 2	1	
19	6X4-24364-00	STAY	1	
20	97095-06016	BOLT	2	
21	92995-06600	WASHER	2	
22	90465-13M24	CLAMP	5	
23	90465-13M30	CLAMP	1	

6X4 TILLER HANDLE FITTING KIT
STEERING FRICTION (F75,F90,F115)

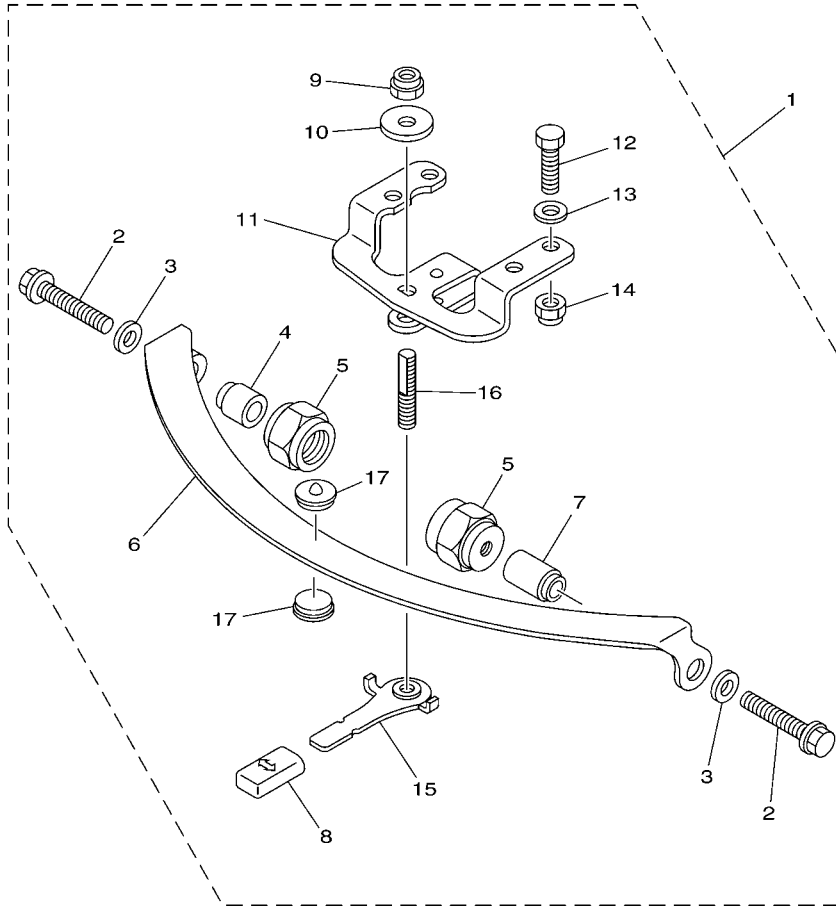

6011100-G630

FIG. 5 STEERING FRICTION 1

REF. NO.	PART NO.	DESCRIPTION	QTY				REMARKS
1	67G-42508-10	STEERING FRICTION ASSY	1				
2	90119-08M74	.BOLT, WITH WASHER	2				
3	90201-08M01	.WASHER, PLATE	2				
4	67G-42541-00	.PIPE 1	1				
5	67G-42546-00	.NUT	2				
6	63D-42527-00	.PLATE, FRICTION	1				
7	67G-42541-10	.PIPE 1	1				
8	682-43318-01	.COVER	1				
9	90185-10M14	.NUT, SELF-LOCKING	1				
10	90201-10M76	.WASHER, PLATE	1				
11	6X4-42526-00	.PLATE, FRICTION	1				
12	97095-08025	.BOLT	2				
13	92995-08600	.WASHER	2				
14	90185-08057	.NUT, SELF-LOCKING	2				
15	67G-42561-00	.KNOB, STEERING LOCK	1				
16	67G-42562-00	.SHAFT, STEERING LOCK	1				
17	63D-42528-00	.PLATE, FRICTION	2				

**6X4 TILLER HANDLE FITTING KIT
STEERING FRICTION (F50,T50,F60,T60,F70)**

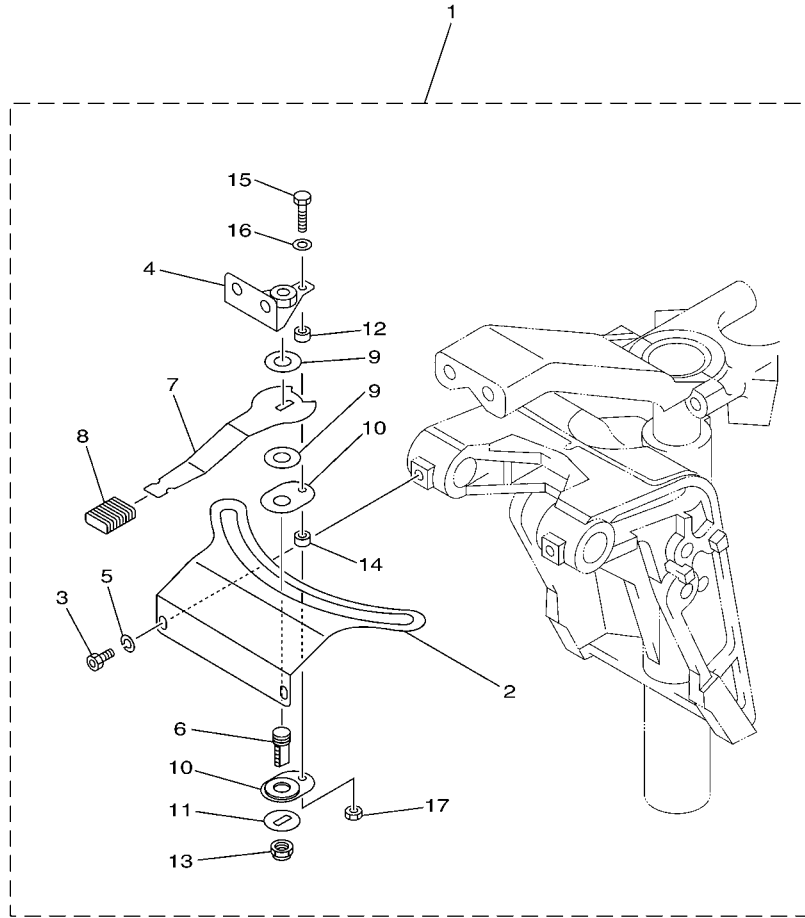

601S10S-K070

FIG. 7 STEERING FRICTION 2

REF. NO.	PART NO.	DESCRIPTION	QTY	REMARKS
1	6C5-42508-00	STEERING FRICTION ASSY	1	
2	6C5-42527-00	.PLATE, FRICTION	1	
3	90109-06M88	.BOLT	2	
4	67C-42525-00	.PLATE, FRICTION	1	
5	92990-06100	.WASHER, SPRING	2	
6	67C-42562-00	.SHAFT, STEERING LOCK	1	
7	67C-42561-00	.KNOB, STEERING LOCK	1	
8	689-43633-00	.COVER, TILT LEVER	1	
9	90202-10M56	.WASHER, PLATE	2	
10	65W-42528-00	.PLATE, FRICTION	2	
11	90209-10M26	.WASHER	1	
12	90387-05M05	.COLLAR	1	
13	90185-10M14	.NUT, SELF-LOCKING	1	
14	90387-05M11	.COLLAR	1	
15	97095-05020	.BOLT	1	
16	92995-05600	.WASHER	1	
17	95380-05600	.NUT	1	

6X4 TILLER HANDLE FITTING KIT (90)

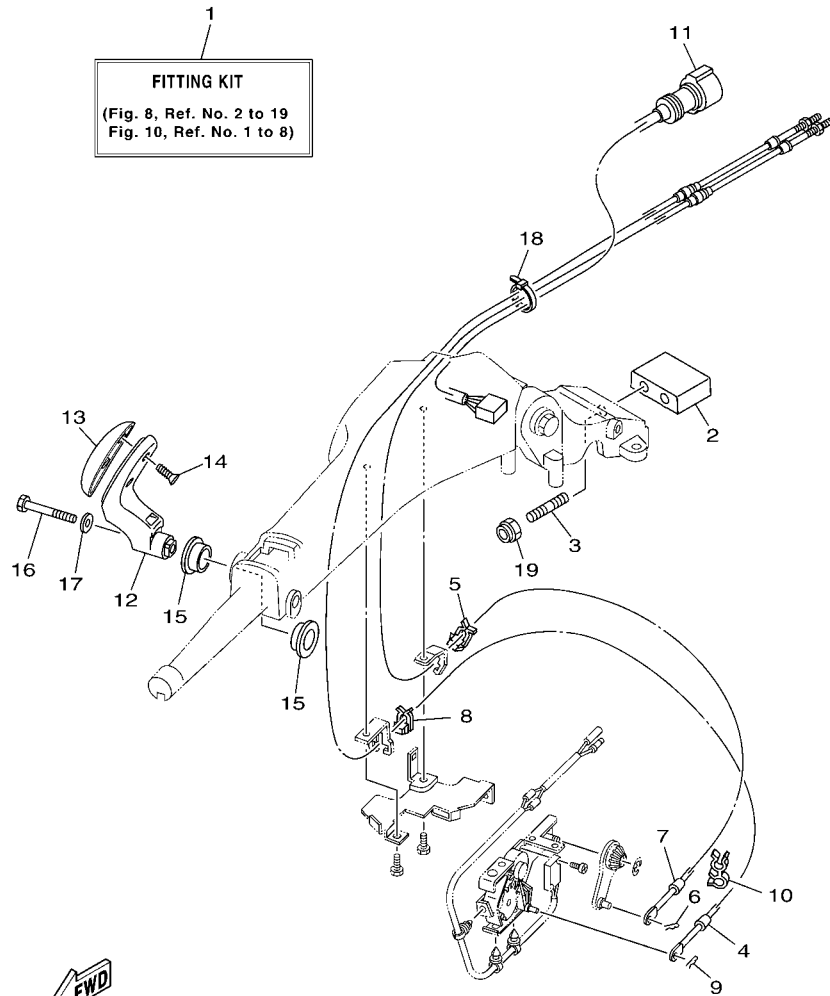

601S10S-J080

FIG. 8 FITTING KIT 4

REF. NO.	PART NO.	DESCRIPTION	601S				REMARKS
1	6X4-42102-41	FITTING KIT	1				LM
2	6X4-42121-00-8D	BRACKET	1				
3	90116-10031	BOLT, STUD	2				
4	6H1-48321-11	CABLE	1				
5	63D-48538-00	CLAMP, CABLE 1	1				
6	90468-10005	CLIP	1				
7	6H1-26301-01	THROTTLE CABLE ASSY	1				
8	63D-48538-00	CLAMP, CABLE 1	1				
9	90468-10005	CLIP	1				
10	90464-09M42	CLAMP	1				
11	6X4-82586-30	EXTENSION, WIRE HARNESS	1				
12	6X4-44159-10-8D	HANDLE, GEAR SHIFT	1				
13	6X4-44173-00	LEVER, SHIFT CONTROL	1				
14	97780-60920	SCREW, TAPPING	2				
15	90386-26MA3	BUSH	1				
16	97095-08040	BOLT	1				
17	92995-08600	WASHER	1				
18	90465-13M36	CLAMP	1				
19	90185-10051	NUT, SELF-LOCKING	2				

6X4 TILLER HANDLE FITTING KIT (70)

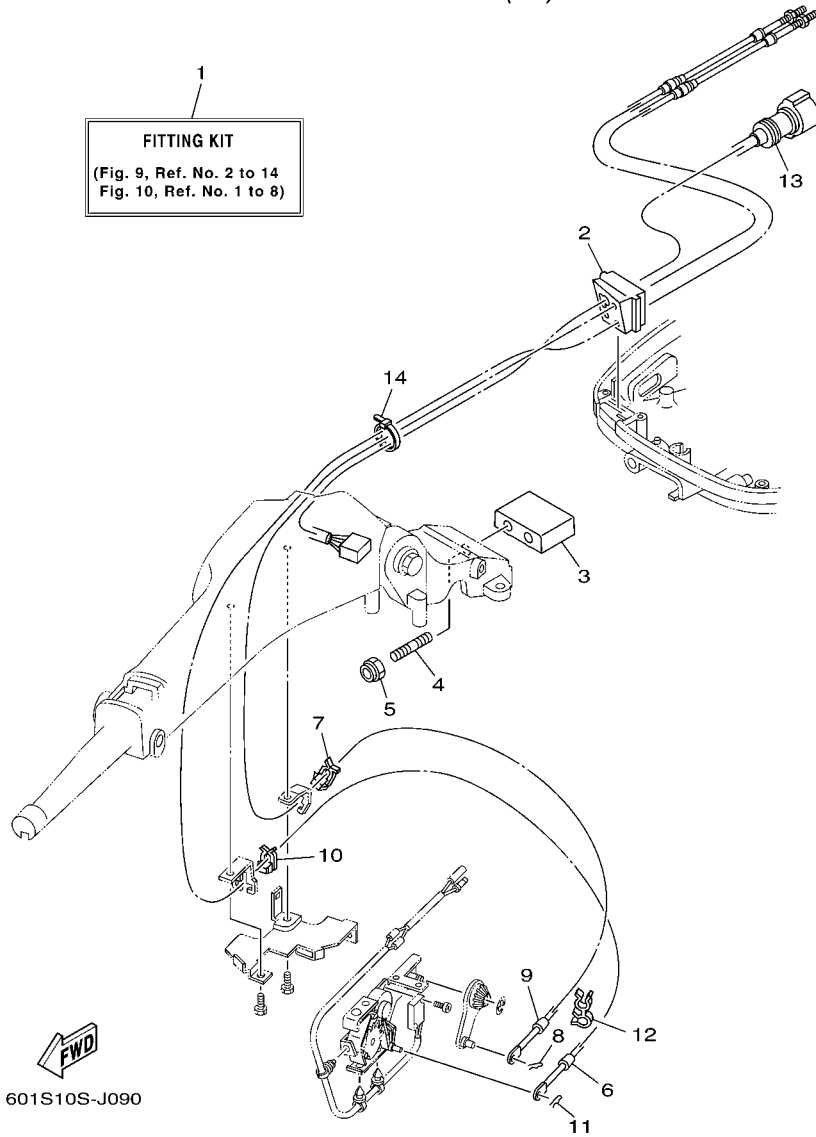
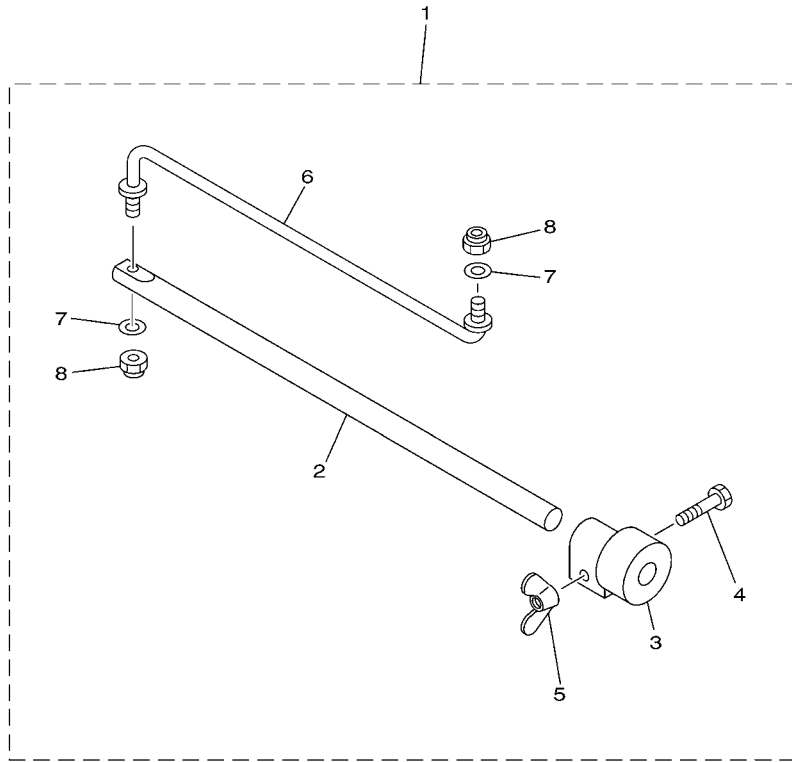

FIG. 9 FITTING KIT 5

REF. NO.	PART NO.	DESCRIPTION	601S				REMARKS
1	6X4-42102-51	FITTING KIT	1				LM
2	6H3-42725-30	GROMMET	1				
3	6X4-42121-00-8D	BRACKET	1				
4	90116-10031	BOLT, STUD	2				
5	90185-10051	NUT, SELF-LOCKING	2				
6	6H3-48321-11	CABLE	1				
7	63D-48538-00	CLAMP, CABLE 1	1				
8	90468-10005	CLIP	1				
9	6H3-26301-01	THROTTLE CABLE ASSY	1				
10	63D-48538-00	CLAMP, CABLE 1	1				
11	90468-10005	CLIP	1				
12	90464-09M42	CLAMP	1				
13	6X4-82586-30	EXTENSION, WIRE HARNESS	1				
14	90465-13M36	CLAMP	1				

**6X4 TILLER HANDLE FITTING KIT
STEERING FRICTION (70,90)**



6011100-G700

FIG. 10 STEERING FRICTION 3

REF. NO.	PART NO.	DESCRIPTION	QTY	REMARKS
1	692-42508-01	STEERING FRICTION ASSY	1	
2	663-42518-00	.SHAFT, FRICTION	1	
3	663-42528-00	.PLATE, FRICTION	1	
4	97080-06035	.BOLT	1	
5	90175-06003	.NUT, WING	1	
6	692-42515-01	.ROD, STEERING LINK	1	
7	92990-08600	.WASHER, PLATE	2	
8	90185-08057	.NUT, SELF-LOCKING	2	

6X4 TILLER HANDLE FITTING KIT
STEERING FRICTION (50)

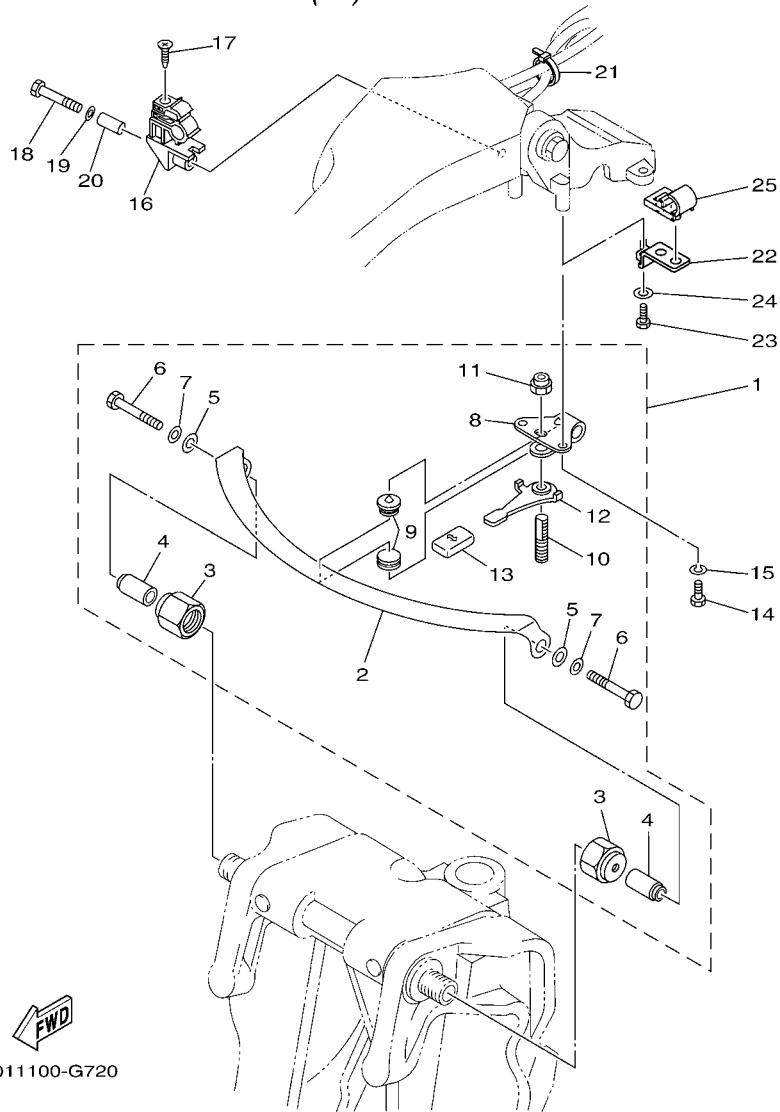

6011100-G720

FIG. 12 STEERING FRICTION 4

REF. NO.	PART NO.	DESCRIPTION	QTY	REMARKS
1	63D-42508-00	STEERING FRICTION ASSY	1	
2	63D-42527-00	.PLATE, FRICTION	1	
3	63D-42546-00	.NUT	2	
4	63D-42541-00	.PIPE 1	2	
5	90201-08M01	.WASHER, PLATE	2	
6	97095-08050	.BOLT	2	
7	92990-08600	.WASHER, PLATE	2	
8	63D-42526-00	.PLATE, FRICTION	1	
9	63D-42528-00	.PLATE, FRICTION	2	
10	63D-42562-00	.SHAFT, STEERING LOCK	1	
11	90185-10M01	.NUT, SELF-LOCKING	1	
12	63D-42561-00	.KNOB, STEERING LOCK	1	
13	682-43318-01	.COVER	1	
14	97095-06016	BOLT	2	
15	92995-06100	WASHER, SPRING	2	
16	63D-82361-00	CLAMP, CORD	1	
17	90161-06M00	SCREW, TAPPING	1	
18	97095-06035	BOLT	1	
19	92995-06600	WASHER	1	
20	90387-06M26	COLLAR	1	
21	90465-13M36	CLAMP	1	
22	63D-24364-10	STAY	1	
23	97095-06016	BOLT	1	
24	92995-06600	WASHER	1	
25	63D-24367-00	CLAMP, FUEL PIPE 2	1	

6X4 TILLER HANDLE FITTING KIT (F40-FI)

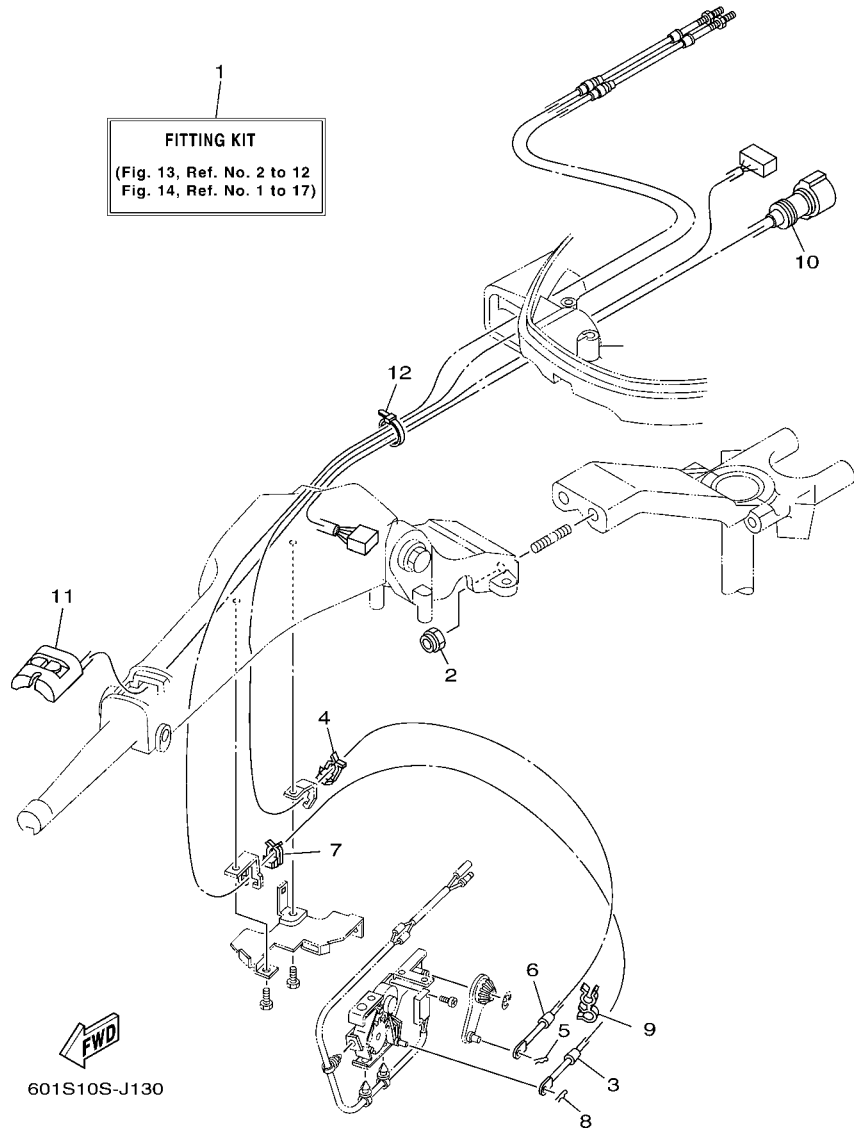
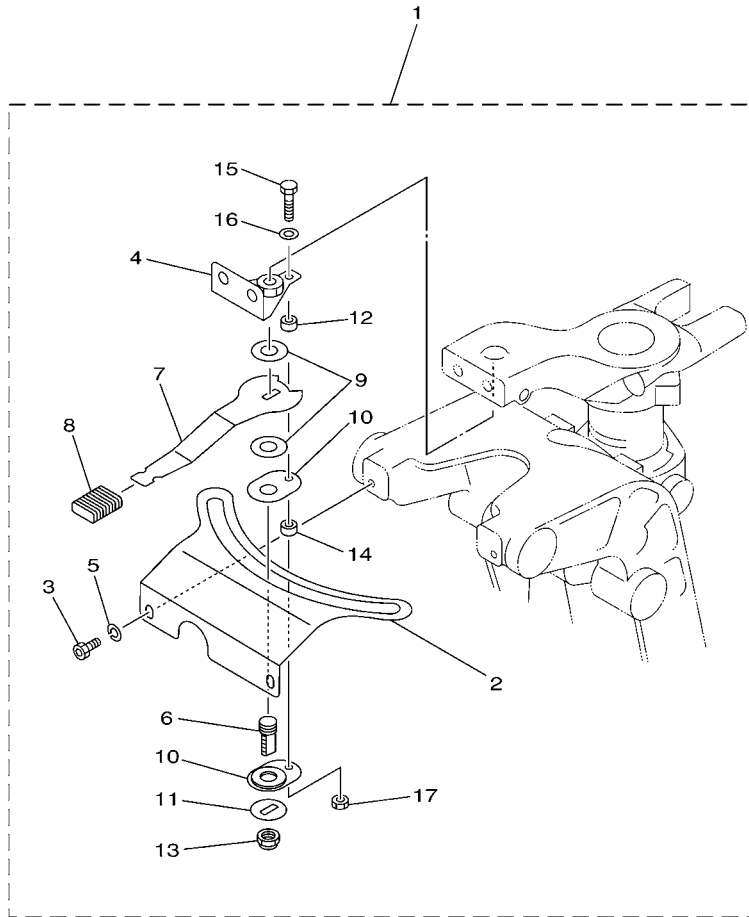

FIG. 13 FITTING KIT 7

REF. NO.	PART NO.	DESCRIPTION	601S				REMARKS
1	6X4-42102-70	FITTING KIT	1				LM
2	90185-10051	NUT, SELF-LOCKING	2				
3	67C-48321-11	CABLE	1				
4	63D-48538-00	CLAMP, CABLE 1	1				
5	90468-10005	CLIP	1				
6	69W-26301-00	THROTTLE CABLE ASSY	1				
7	63D-48538-00	CLAMP, CABLE 1	1				
8	90468-10005	CLIP	1				
9	90464-09M42	CLAMP	1				
10	6X4-82586-10	EXT., WIRE HARNESS (L:950MM)	1				
11	6X4-81860-00	SWITCH ASSY	1				
12	90465-13M36	CLAMP	1				

6X4 TILLER HANDLE FITTING KIT
STEERING FRICTION (F40-FI)



601S10S-J140

FIG. 14 STEERING FRICTION 5

REF. NO.	PART NO.	DESCRIPTION	601S				REMARKS
1	67C-42508-03	STEERING FRICTION ASSY	1				
2	67C-42527-03	.PLATE, FRICTION	1				
3	90109-06M88	.BOLT	2				
4	67C-42525-00	.PLATE, FRICTION	1				
5	92990-06100	.WASHER, SPRING	2				
6	67C-42562-00	.SHAFT, STEERING LOCK	1				
7	67C-42561-00	.KNOB, STEERING LOCK	1				
8	689-43633-00	.COVER, TILT LEVER	1				
9	90202-10M56	.WASHER, PLATE	2				
10	65W-42528-00	.PLATE, FRICTION	2				
11	90209-10M26	.WASHER	1				
12	90387-05M05	.COLLAR	1				
13	90185-10M14	.NUT, SELF-LOCKING	1				
14	90387-05M11	.COLLAR	1				
15	97095-05020	.BOLT	1				
16	92995-05600	.WASHER	1				
17	95380-05600	.NUT	1				

STEERING FRICTION

Part No.	Applicable model
6AH-42508-00	F9.9F(F9.9), F9.9H, FT9.9G(T9.9), F15C (F15), F20B (F20), F20C MT
6AH-42508-10	FT9.9G(T9.9), F15C (F15), F20B (F20) PT

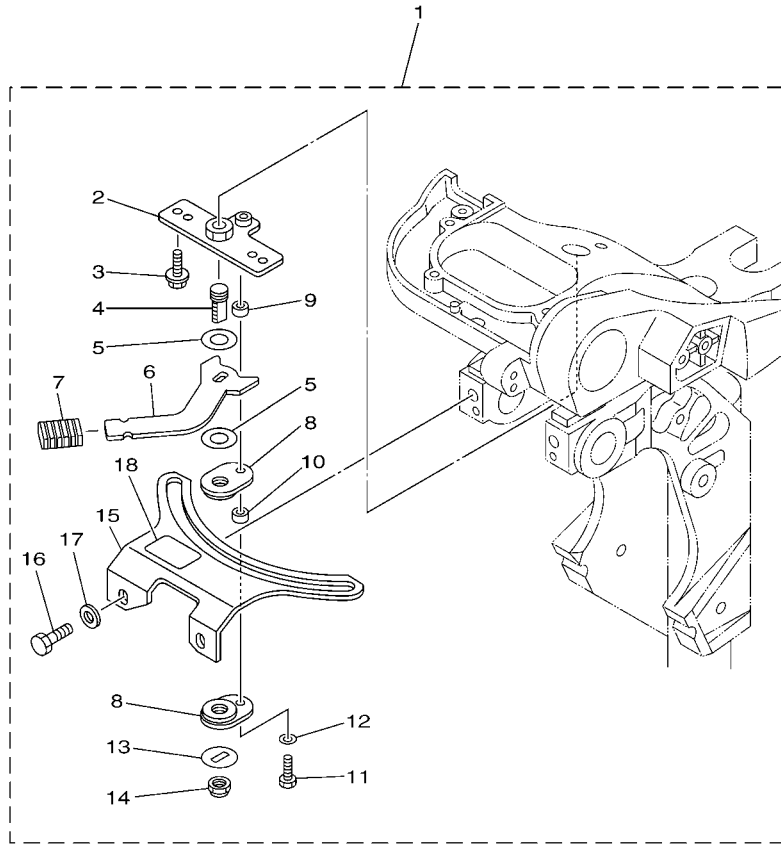

601S10S-J150

FIG. 15 STEERING FRICTION 6

REF. NO.	PART NO.	DESCRIPTION	601S				REMARKS
1	6AH-42508-00	STEERING FRICTION ASSY	1				UR
	6AH-42508-10	STEERING FRICTION ASSY	1				UR
2	68T-42525-01	.PLATE, FRICTION	1				
3	90119-05018	.BOLT, WITH WASHER	2				
4	67C-42562-00	.SHAFT, STEERING LOCK	1				
5	90202-10M56	.WASHER, PLATE	2				
6	68T-42561-00	.KNOB, STEERING LOCK	1				
7	689-43633-00	.COVER, TILT LEVER	1				
8	65W-42528-00	.PLATE, FRICTION	2				
9	90387-05M05	.COLLAR	1				
10	90387-05M11	.COLLAR	1				
11	97095-05020	.BOLT	1				
12	92995-05600	.WASHER	1				
13	90209-10M26	.WASHER	1				
14	90185-10M14	.NUT, SELF-LOCKING	1				
15	6AH-42527-00	.PLATE, FRICTION	1				
16	90101-08022	.BOLT	2				
17	90201-08065	.WASHER, PLATE	2				
18	68T-43155-00	.MARK 1	1				FOR 6AH-42508-00

STEERING FRICTION

Part No.	Applicable model
65W-42508-00	F25D (F25), (E)40X

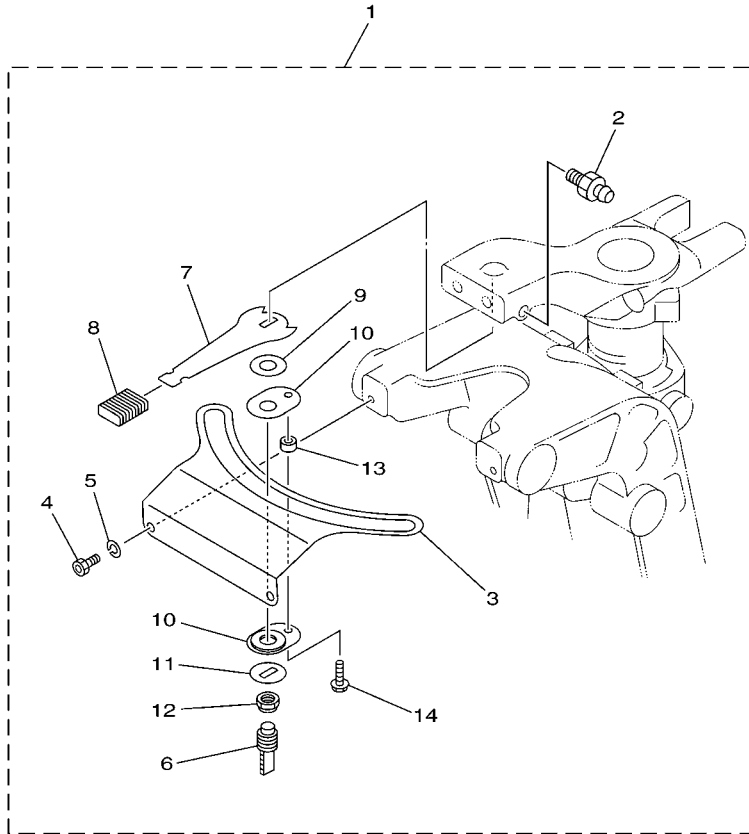

601S10S-J160

FIG. 16 STEERING FRICTION 7

REF. NO.	PART NO.	DESCRIPTION	601S				REMARKS
1	65W-42508-00	STEERING FRICTION ASSY	1				
2	93700-06M03	.NIPPLE, GREASE	1				
3	65W-42527-00	.PLATE, FRICTION	1				
4	90109-06M88	.BOLT	2				
5	92990-06100	.WASHER, SPRING	2				
6	65W-42562-00	.SHAFT, STEERING LOCK	1				
7	65W-42561-00	.KNOB, STEERING LOCK	1				
8	689-43633-00	.COVER, TILT LEVER	1				
9	90202-10M56	.WASHER, PLATE	1				
10	65W-42528-00	.PLATE, FRICTION	2				
11	90209-10M26	.WASHER	1				
12	90185-10M14	.NUT, SELF-LOCKING	1				
13	90387-05M11	.COLLAR	1				
14	90109-05M89	.BOLT	1				

STEERING FRICTION

Part No.	Applicable model
67C-42508-03	F30B (F30), F40F(F40)

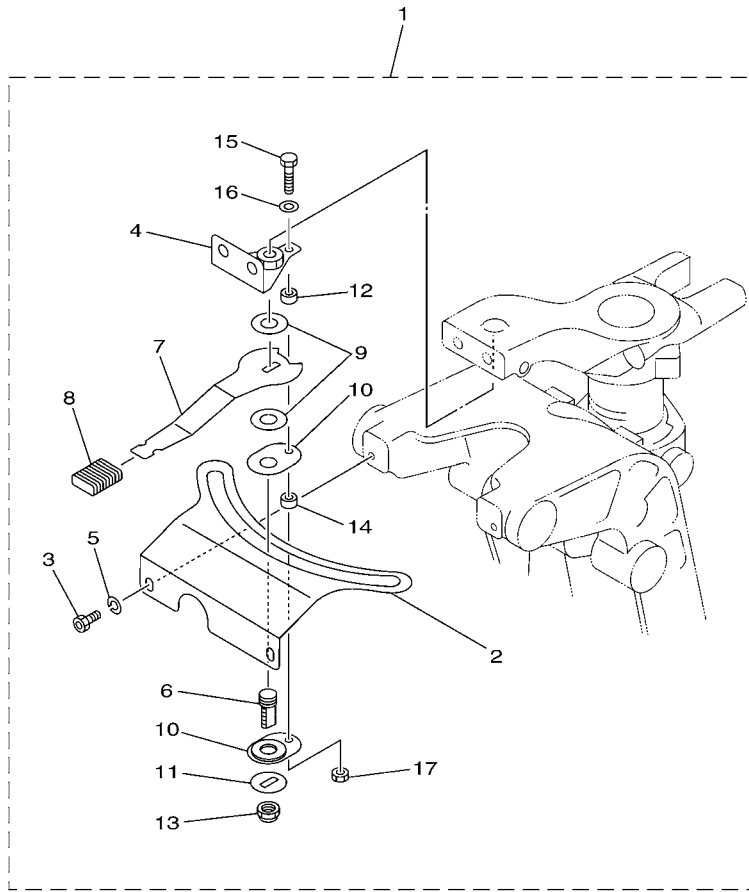

601S10S-J170

FIG. 17 STEERING FRICTION 8

REF. NO.	PART NO.	DESCRIPTION	601S				REMARKS
1	67C-42508-03	STEERING FRICTION ASSY	1				
2	67C-42527-03	.PLATE, FRICTION	1				
3	90109-06M88	.BOLT	2				
4	67C-42525-00	.PLATE, FRICTION	1				
5	92990-06100	.WASHER, SPRING	2				
6	67C-42562-00	.SHAFT, STEERING LOCK	1				
7	67C-42561-00	.KNOB, STEERING LOCK	1				
8	689-43633-00	.COVER, TILT LEVER	1				
9	90202-10M56	.WASHER, PLATE	2				
10	65W-42528-00	.PLATE, FRICTION	2				
11	90209-10M26	.WASHER	1				
12	90387-05M05	.COLLAR	1				
13	90185-10M14	.NUT, SELF-LOCKING	1				
14	90387-05M11	.COLLAR	1				
15	97095-05020	.BOLT	1				
16	92995-05600	.WASHER	1				
17	95380-05600	.NUT	1				

STEERING FRICTION

Part No.	Applicable model
63D-42508-00	FT50C, F50D, 40V, 50H (50)

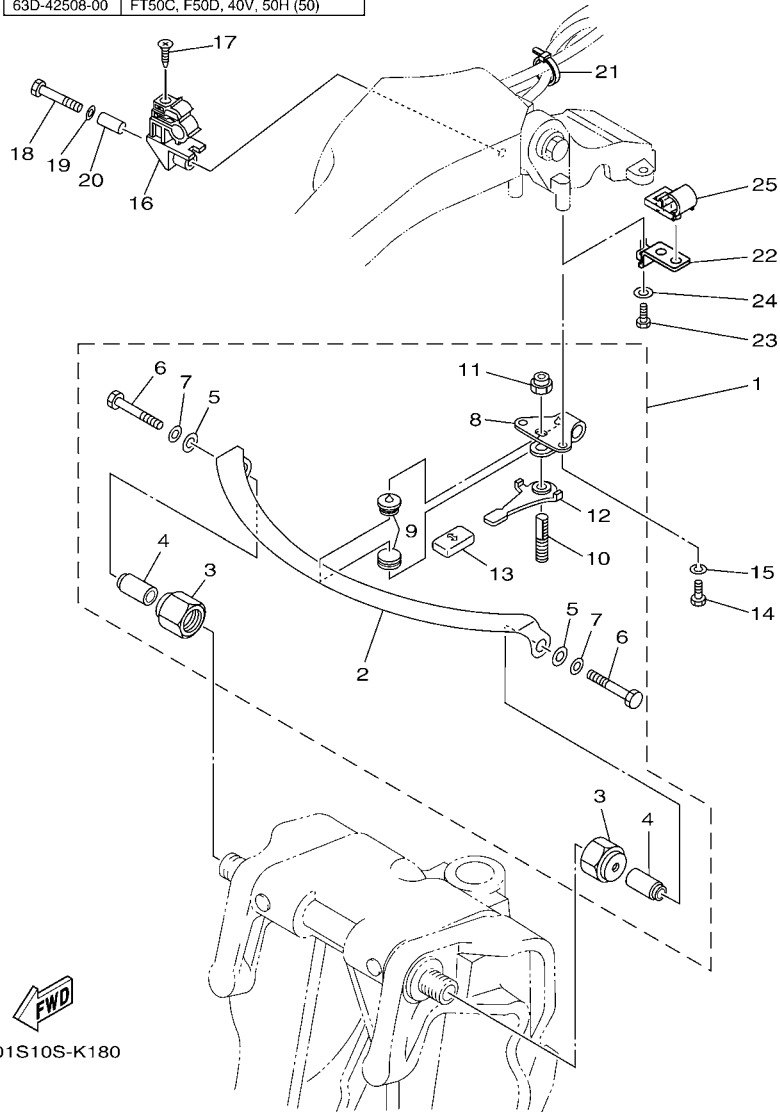

601S10S-K180

FIG. 18 STEERING FRICTION 9

REF. NO.	PART NO.	DESCRIPTION	601S				REMARKS
1	63D-42508-00	STEERING FRICTION ASSY	1				
2	63D-42527-00	.PLATE, FRICTION	1				
3	63D-42546-00	.NUT	2				
4	63D-42541-00	.PIPE 1	2				
5	90201-08M01	.WASHER, PLATE	2				
6	97095-08050	.BOLT	2				
7	92990-08600	.WASHER, PLATE	2				
8	63D-42526-00	.PLATE, FRICTION	1				
9	63D-42528-00	.PLATE, FRICTION	2				
10	63D-42562-00	.SHAFT, STEERING LOCK	1				
11	90185-10M01	.NUT, SELF-LOCKING	1				
12	63D-42561-00	.KNOB, STEERING LOCK	1				
13	682-43318-01	.COVER	1				
14	97095-06016	BOLT	2				
15	92995-06100	WASHER, SPRING	2				
16	63D-82361-00	CLAMP, CORD	1				
17	90161-06M00	SCREW, TAPPING	1				
18	97095-06035	BOLT	1				
19	92995-06600	WASHER	1				
20	90387-06M26	COLLAR	1				
21	90465-13M36	CLAMP	1				
22	63D-24364-10	STAY	1				
23	97095-06016	BOLT	1				
24	92995-06600	WASHER	1				
25	63D-24367-00	CLAMP, FUEL PIPE 2	1				

STEERING FRICTION

Part No.	Applicable model
6C5-42508-00	F50F (F50), FT50G (T50), F60C (F60), FT60D (T60), F40D, F70A (F70)

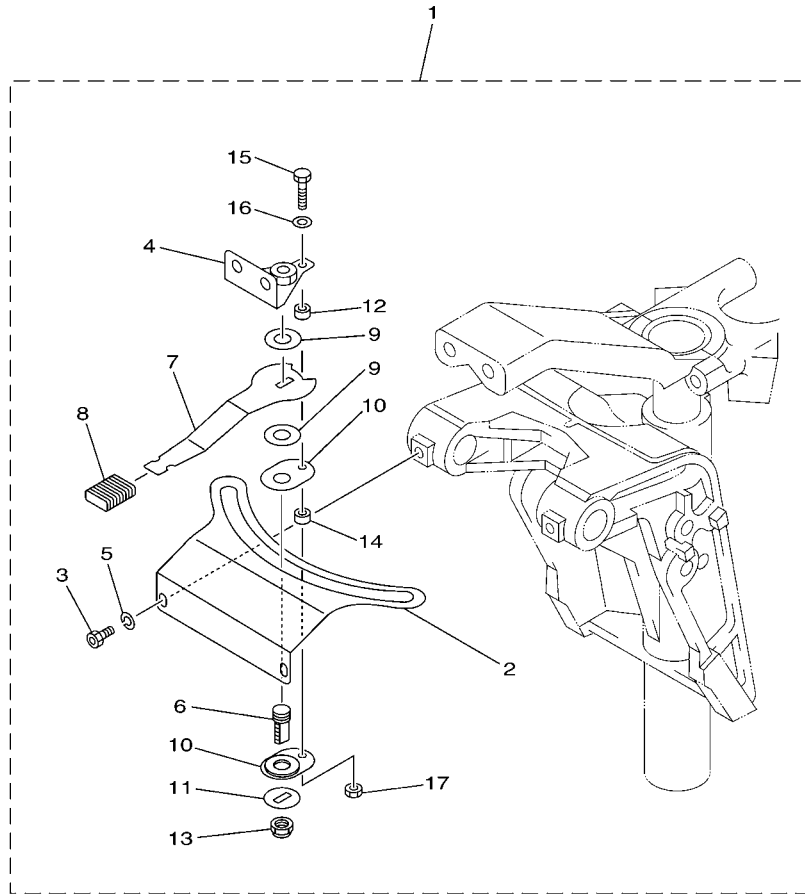

601S10S-K200

FIG. 20 STEERING FRICTION 11

REF. NO.	PART NO.	DESCRIPTION	601S				REMARKS
1	6C5-42508-00	STEERING FRICTION ASSY	1				
2	6C5-42527-00	.PLATE, FRICTION	1				
3	90109-06M88	.BOLT	2				
4	67C-42525-00	.PLATE, FRICTION	1				
5	92990-06100	.WASHER, SPRING	2				
6	67C-42562-00	.SHAFT, STEERING LOCK	1				
7	67C-42561-00	.KNOB, STEERING LOCK	1				
8	689-43633-00	.COVER, TILT LEVER	1				
9	90202-10M56	.WASHER, PLATE	2				
10	65W-42528-00	.PLATE, FRICTION	2				
11	90209-10M26	.WASHER	1				
12	90387-05M05	.COLLAR	1				
13	90185-10M14	.NUT, SELF-LOCKING	1				
14	90387-05M11	.COLLAR	1				
15	97095-05020	.BOLT	1				
16	92995-05600	.WASHER	1				
17	95380-05600	.NUT	1				

STEERING FRICTION

Part No.	Applicable model
67G-42508-10	F75B (F75), F80B, F90B (F90), F95A, F100D, F100B, F115A (F115), F75C, F80C

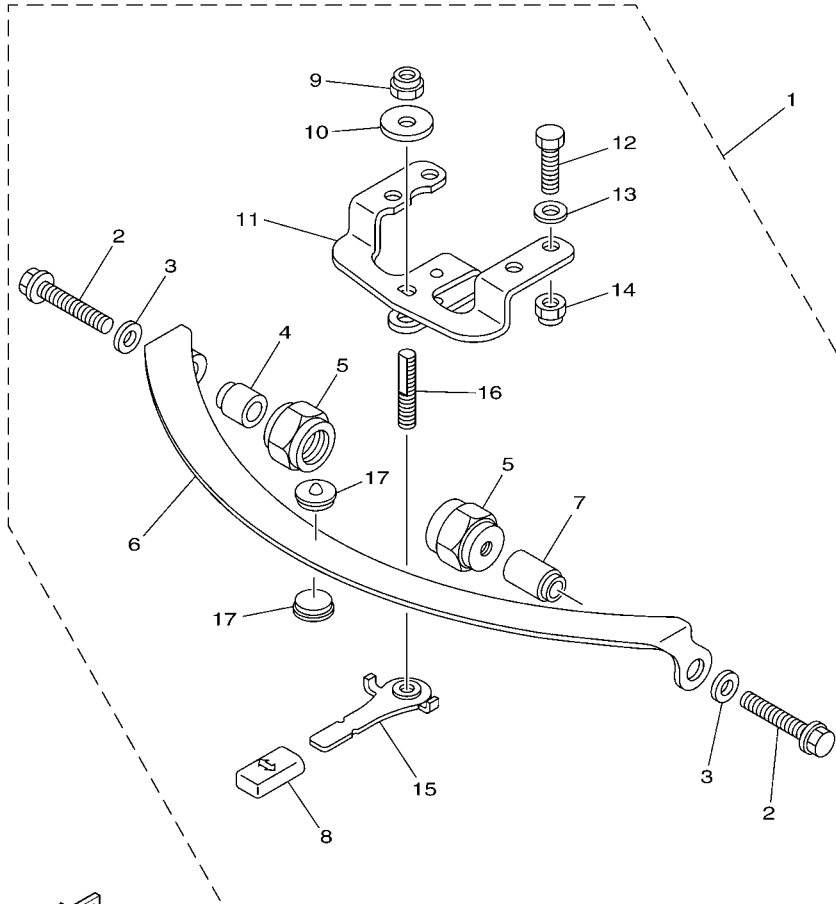

601S10S-H230

FIG. 21 STEERING FRICTION 12

REF. NO.	PART NO.	DESCRIPTION	601S				REMARKS
1	67G-42508-10	STEERING FRICTION ASSY	1				
2	90119-08M74	.BOLT, WITH WASHER	2				
3	90201-08M01	.WASHER, PLATE	2				
4	67G-42541-00	.PIPE 1	1				
5	67G-42546-00	.NUT	2				
6	63D-42527-00	.PLATE, FRICTION	1				
7	67G-42541-10	.PIPE 1	1				
8	682-43318-01	.COVER	1				
9	90185-10M14	.NUT, SELF-LOCKING	1				
10	90201-10M76	.WASHER, PLATE	1				
11	6X4-42526-00	.PLATE, FRICTION	1				
12	97095-08025	.BOLT	2				
13	92995-08600	.WASHER	2				
14	90185-08057	.NUT, SELF-LOCKING	2				
15	67G-42561-00	.KNOB, STEERING LOCK	1				
16	67G-42562-00	.SHAFT, STEERING LOCK	1				
17	63D-42528-00	.PLATE, FRICTION	2				

NUMERICAL INDEX

PART NO.	REF. NO.	PART NO.	REF. NO.	PART NO.	REF. NO.	PART NO.	REF. NO.	PART NO.	REF. NO.	PART NO.	REF. NO.
6X4-14137-00	1 - 26	692-42508-01	19 - 1	63D-42546-00	18 - 3	6X4-44159-10-8D	8 - 12	6X4-82586-00	11 - 11	90185-10M14	16 - 12
6X4-24364-00	3 - 18	67C-42508-03	14 - 1	67G-42546-00	5 - 5	6X4-44173-00	1 - 43	6X4-82586-10	6 - 10		17 - 13
	4 - 19		17 - 1		21 - 5		8 - 13		13 - 10		20 - 13
63D-24364-10	12 - 22	67G-42508-10	5 - 1	63D-42561-00	12 - 12	6X4-44177-00	1 - 12	6X4-82586-20	3 - 13		21 - 9
	18 - 22		21 - 1		18 - 12	6X4-44188-00	1 - 15		4 - 13	90185-12M12	1 - 59
63D-24367-00	3 - 17	6AH-42508-10	15 - 1	65W-42561-00	16 - 7	6G8-44191-00	1 - 45	6X4-82586-30	8 - 11	90201-08065	15 - 17
	4 - 18	692-42515-01	10 - 6	67C-42561-00	7 - 7	6X4-47731-00	1 - 24		9 - 13	90201-08M01	5 - 3
	12 - 25		19 - 6		14 - 7	6A5-48129-10	1 - 29	6X4-83383-00	2 - 10		12 - 5
	18 - 25	663-42518-00	10 - 2		17 - 7	6X4-48154-00	1 - 18	6X4-83386-00	2 - 11		18 - 5
69W-26301-00	6 - 6		19 - 2		20 - 7	6X4-48215-00	1 - 4	6G5-83557-00	3 - 15		21 - 3
	13 - 6	67C-42525-00	7 - 4	67G-42561-00	5 - 15	6X4-48261-00	1 - 27	6K3-83557-00	4 - 16	90201-10M76	5 - 10
63D-26301-01	11 - 7		14 - 4		21 - 15	63D-48321-11	11 - 4	90101-08022	15 - 16		21 - 10
6H1-26301-01	8 - 7		17 - 4	68T-42561-00	15 - 6	67C-48321-11	6 - 3	90101-12014	1 - 52	90201-12035	1 - 56
6H3-26301-01	9 - 9		20 - 4	63D-42562-00	12 - 10		13 - 3	90109-05M89	16 - 14	90202-10M56	7 - 9
67G-26301-10	3 - 9	68T-42525-01	15 - 2		18 - 10	6H1-48321-11	8 - 4	90109-06M88	7 - 3		14 - 9
	4 - 9	63D-42526-00	12 - 8	65W-42562-00	16 - 6	6H3-48321-11	9 - 6		14 - 3		15 - 5
6X4-26367-00	1 - 36		18 - 8	67C-42562-00	7 - 6	67G-48321-20	3 - 6		16 - 4		16 - 9
	1 - 39	6X4-42526-00	5 - 11		14 - 6		4 - 6		17 - 3		17 - 9
6X4-41291-00	1 - 8		21 - 11		15 - 4	63D-48538-00	3 - 7		20 - 3		20 - 9
6X4-42102-00	3 - 1	63D-42527-00	5 - 6		17 - 6		3 - 10	90116-10031	4 - 5	90206-12M22	1 - 54
6X4-42102-10	4 - 1		12 - 2		20 - 6		4 - 7		8 - 3	90209-10M26	7 - 11
6X4-42102-22	6 - 1		18 - 2	67G-42562-00	5 - 16		4 - 10		9 - 4		14 - 11
6X4-42102-41	8 - 1		21 - 6		21 - 16		6 - 4	90116-10175	3 - 4		15 - 13
6X4-42102-51	9 - 1	65W-42527-00	16 - 3	6H4-42724-20	11 - 2		6 - 7	90119-05018	15 - 3		16 - 11
6X4-42102-61	11 - 1	6AH-42527-00	15 - 15	6X4-42725-01	1 - 50		8 - 5	90119-08M74	5 - 2		17 - 11
6X4-42102-70	13 - 1	6C5-42527-00	7 - 2	68V-42725-10	3 - 2		8 - 8		21 - 2		20 - 11
6X4-42103-50	1 - 1		20 - 2		4 - 2		9 - 7	90152-05007	1 - 10	90386-08032	1 - 16
6X4-42111-02-8D	1 - 2	67C-42527-03	14 - 2	6H3-42725-30	9 - 2		9 - 10	90161-06M00	12 - 17	90386-12003	1 - 57
6X4-42115-00	1 - 22		17 - 2	6X4-42728-10	1 - 60		11 - 5		18 - 17	90386-26MA3	1 - 46
6X4-42119-01	1 - 5	63D-42528-00	5 - 17	6X4-42735-00	3 - 16		11 - 8	90175-06003	10 - 5		8 - 15
6X4-42121-00-8D	4 - 3		12 - 9		4 - 17		13 - 4		19 - 5	90387-05M05	7 - 12
	8 - 2		18 - 9	6X4-42821-00	1 - 30		13 - 7	90185-08057	5 - 14		14 - 12
	9 - 3		21 - 17	68T-43155-00	15 - 18	6X4-48538-00	1 - 35		10 - 8		15 - 9
6X4-42121-11-8D	3 - 3	65W-42528-00	7 - 10	682-43318-01	5 - 8	6X4-48538-10	1 - 38		19 - 8		17 - 12
63D-42121-22-8D	1 - 51		14 - 10		12 - 13	6X4-81860-00	4 - 14		21 - 14		20 - 12
63D-42126-00	1 - 17		15 - 8		18 - 13		6 - 11	90185-10051	3 - 5	90387-05M11	7 - 14
6X4-42128-00	1 - 13		16 - 10		21 - 8		13 - 11		4 - 4		14 - 14
6X4-42131-01	1 - 47		17 - 10	689-43633-00	7 - 8	6X4-81942-00	2 - 13		6 - 2		15 - 10
6X4-42137-00	1 - 7		20 - 10		14 - 8	63D-82361-00	12 - 16		8 - 19		16 - 13
6X4-42159-00	1 - 41	663-42528-00	10 - 3		15 - 7		18 - 16		9 - 5		17 - 14
6X4-42177-00	1 - 6		19 - 3		16 - 8	6X4-82510-00	2 - 1		11 - 3		20 - 14
63D-42508-00	12 - 1	63D-42541-00	12 - 4		17 - 8	703-82532-00	2 - 3		13 - 2	90387-06M26	12 - 20
	18 - 1		18 - 4		20 - 8	6X4-82540-00	1 - 28	90185-10M01	12 - 11		18 - 20
65W-42508-00	16 - 1	67G-42541-00	5 - 4	6X4-44100-00	1 - 21	682-82556-00	2 - 6		18 - 11	90387-12M02	1 - 55
6AH-42508-00	15 - 1		21 - 4	6X4-44102-00	1 - 23	6X4-82563-00	2 - 8	90185-10M14	5 - 9	90447-22007	3 - 14
6C5-42508-00	7 - 1	67G-42541-10	5 - 7	6X4-44132-00	1 - 25	69W-82575-00	2 - 5		7 - 13		4 - 15
	20 - 1		21 - 7	6X4-44139-01	1 - 9	676-82577-00	2 - 2		14 - 13	90464-08M07	2 - 4
692-42508-01	10 - 1	63D-42546-00	12 - 3	6X4-44159-00-8D	1 - 42	689-8257Y-00	2 - 7		15 - 14	90464-09M42	3 - 12

NUMERICAL INDEX

PART NO.	REF. NO.	PART NO.	REF. NO.	PART NO.	REF. NO.	PART NO.	REF. NO.	PART NO.	REF. NO.	PART NO.	REF. NO.
90464-09M42	4 - 12	92995-05600	20 - 16	97780-60920	8 - 14						
	6 - 9	92995-06100	12 - 15	97885-06016	1 - 48						
	8 - 10		18 - 15	97980-06216	2 - 9						
	9 - 12	92995-06600	1 - 34								
	11 - 10		1 - 49								
	13 - 9		3 - 20								
90465-13M24	3 - 21		4 - 21								
	4 - 22		12 - 19								
90465-13M30	3 - 22		12 - 24								
	4 - 23		18 - 19								
90465-13M36	6 - 12		18 - 24								
	8 - 18	92995-08600	1 - 32								
	9 - 14		5 - 13								
	12 - 21		8 - 17								
	13 - 12		21 - 13								
	18 - 21	93700-06M03	1 - 3								
90468-10005	3 - 8		16 - 2								
	3 - 11	95380-05600	7 - 17								
	4 - 8		14 - 17								
	4 - 11		17 - 17								
	6 - 5		20 - 17								
	6 - 8	95380-06600	1 - 19								
	8 - 6	97080-06035	10 - 4								
	8 - 9		19 - 4								
	9 - 8	97095-05020	7 - 15								
	9 - 11		14 - 15								
	11 - 6		15 - 11								
	11 - 9		17 - 15								
	13 - 5		20 - 15								
	13 - 8	97095-06014	1 - 37								
90501-23215	1 - 14		1 - 40								
91490-20010	1 - 11		2 - 12								
	1 - 20	97095-06016	3 - 19								
92990-06100	7 - 5		4 - 20								
	14 - 5		12 - 14								
	16 - 5		12 - 23								
	17 - 5		18 - 14								
	20 - 5		18 - 23								
92990-08600	10 - 7	97095-06030	1 - 33								
	12 - 7	97095-06035	12 - 18								
	18 - 7		18 - 18								
	19 - 7	97095-08025	5 - 12								
92990-12200	1 - 53		21 - 12								
92990-12600	1 - 58	97095-08040	1 - 31								
92995-05600	7 - 16		8 - 16								
	14 - 16	97095-08050	12 - 6								
	15 - 12		18 - 6								
	17 - 16	97780-60920	1 - 44								