



**PARTS  
CATALOGUE  
CATALOGUE  
DE PIÈCES DÉTACHÉES**

# RIGGING-STEERING

---



1G602-30SF1

( )

RIGGING-STEERING  
PARTS CATALOGUE  
©2008 by Yamaha Motor Co., Ltd.  
1st edition, June 2008  
All rights reserved.  
Any reprinting or unauthorized use  
without the written permission of  
Yamaha Motor Co., Ltd.  
is expressly prohibited.  
Printed in Japan.

RIGGING-STEERING  
CATALOGUE DE PIECES DETACHEES  
©2008 par Yamaha Motor Co., Ltd.  
1<sup>re</sup> édition, juin 2008  
Tous droits réservés  
Toute réimpression ou utilisation  
non autorisée sans la permission écrite  
de la Yamaha Motor Co., Ltd.  
est formellement interdite.  
Imprimé au Japon

# FOREWORD

This Parts Catalogue is related to the parts for the model(s) on the cover page. When you are ordering replacement parts, please refer to this Parts Catalogue and quote both part numbers and part names correctly.

1. Modifications or additions which have been made after the issue of the Parts Catalogue will be announced in the Parts News.

It is advisable that you make the necessary corrections to the Parts Catalogue according to the Parts News.

2. Abbreviations

The following abbreviations are used in this Parts Catalogue.

“UR” Use specified parts number.

“UN” Use as many as needed.

“AP” Alternate Parts

“LM” Locally Made (Parts need to be ordered locally)

“F#” Frame No. (Applicable machine No.)

“O/S” Over Size

3. The number of components for assembly

- Parts, which are to be supplied in an assembly, are listed with a dot (.) in front of the part name as shown below.
- The numeral appearing to the right of each component part indicates the quantity of parts for each assembly unit.

PART NO.	DESCRIPTION	Q'TY	REMARKS
2F5-83310-60	FRONT FLASHER LIGHT ASSY	2	
115-83311-60	.BULB (6V-18W)	1	

4. Applicable colours of graphics are represented in the “REMARKS” as shown below.

PART NO.	DESCRIPTION	Q'TY	REMARKS
2N4-24110-00-X5	FUEL TANK COMP.	2	MXR
3J1-24240-10	.GRAPHIC, FUEL TANK	1	FOR MXR

5. Note that the illustrations for reference in finding parts numbers are not to be used for assembling. When assembling, please use the applicable service manual.

6. The asterisk (\*) before a reference number indicates modified items after the first edition.

# AVANT-PROPOS

Ce catalogue de pièces détachées concerne les pièces pour le(s) modèle(s) indiqué(s) sur la page de couverture. Lorsque vous commandez des pièces de rechange, veuillez vous référer à ce catalogue de pièces détachées et indiquer clairement les numéros et les noms des pièces détachées.

1. Les modifications ou ajouts ayant été effectués après la parution du catalogue de pièces détachées seront décrits dans les Bulletins d'information concernant les pièces détachées.

Il est recommandé que vous apportiez les corrections nécessaires au catalogue des pièces détachées en vous référant aux Bulletins d'information.

2. Abréviations

Dans ce catalogue, les abréviations suivantes sont utilisées:

“UR” Utiliser le numéro de pièces spécifié.

“UN” Utiliser autant que nécessaire.

“AP” Pièces de substitution

“LM” Fabrication locale (les pièces doivent être commandées localement.)

“F#” N° de cadre (applicable au N° de série)

“O/S” Surdimensionné

3. Nombre de pièces d'un assemblage

- Les pièces fournies comme composants d'un assemblage sont précédées d'un point (.) de la manière indiquée ci-dessous.
- Le chiffre apparaissant à la droite de chaque composant indique la quantité de pièces pour chaque unité d'assemblage.

N° PIECES	DESCRIPTION	QTE	REMARQUES
2F5-83310-60	ENS. CLIGNOTANT AVANT	2	
115-83311-60	.AMPOULE (6V-18W)	1	

4. Les couleurs concernant les graphiques sont indiquées dans la colonne “REMARQUES”, comme indiqué ci-dessous.

N° PIECES	DESCRIPTION	QTE	REMARQUES
2N4-24110-00-X5	RESERVOIR A ESSENCE.	2	MXR
3J1-24240-10	.GRAPHIQUE	1	POUR MXR

5. Veuillez noter que les illustrations sont indiquées à titre de référence pour trouver les numéros de pièces, non pour être utilisées lors de l'assemblage. Lors de l'assemblage, veuillez utiliser le manuel d'entretien adéquat.

6. L'astérisque (\*) placé devant un numéro de référence indique des éléments qui ont été modifiés après la première édition.

# CONTENTS

BASE HANDLE - ALL .....	1
BASE HANDLE ELECTRICAL .....	4
FITTING KIT 1 .....	5
FITTING KIT 2 .....	6
STEERING FRICTION 1 .....	7
FITTING KIT 3 .....	8
STEERING FRICTION 2 .....	9
FITTING KIT 4 .....	10
STEERING FRICTION 3 .....	11
FITTING KIT 5 .....	12
FITTING KIT 6 .....	13
STEERING FRICTION 4 .....	14
FITTING KIT 7 .....	15
STEERING FRICTION 5 .....	16
TILLER HANDLE KIT 1 .....	17
TILLER HANDLE KIT 2 .....	20
TILLER HANDLE KIT 3 .....	21
STEERING FRICTION 6 .....	22

## INDEX

NUMERICAL INDEX .....	23
-----------------------	----

# TABLE DES MATIERES

BASE MANCHE - TOUT .....	1
BASE MANCHE ELECTRICAL .....	4
EQUIPEMENT APPROPPIE 1 .....	5
EQUIPEMENT APPROPPIE 2 .....	6
CUVETTE POIGNEE DE DIRECTION 1 .....	7
EQUIPEMENT APPROPPIE 3 .....	8
CUVETTE POIGNEE DE DIRECTION 2 .....	9
EQUIPEMENT APPROPPIE 4 .....	10
CUVETTE POIGNEE DE DIRECTION 3 .....	11
EQUIPEMENT APPROPPIE 5 .....	12
EQUIPEMENT APPROPPIE 6 .....	13
CUVETTE POIGNEE DE DIRECTION 4 .....	14
EQUIPEMENT APPROPPIE 7 .....	15
CUVETTE POIGNEE DE DIRECTION 5 .....	16
POCHETTE DE BARRE FRANCHE 1 .....	17
POCHETTE DE BARRE FRANCHE 2 .....	20
POCHETTE DE BARRE FRANCHE 3 .....	21
CUVETTE POIGNEE DE DIRECTION 6 .....	22

## INDEX

INDEX NUMERIQUE .....	23
-----------------------	----

# Application Model

PART NO. / PART NAME											
FIG.NO.											
MODEL CODE	MODEL NAME	SERIAL NO.	6X4-42101-01 HANDLE, STEERING	6X4-42102-00 FITTING KIT	6X4-42102-10 FITTING KIT	6X4-42102-21 FITTING KIT	6X4-42102-31 FITTING KIT	6X4-42102-41 FITTING KIT	6X4-42102-51 FITTING KIT	6X4-42102-61 FITTING KIT	6X4-42103-02 TILLER HANDLE KIT
			FIG.1, 2	FIG.3, 5	FIG.4, 5	FIG.6, 7	FIG.8, 9	FIG.10, 12	FIG.11, 12	FIG.13, 14	FIG.15, 16, 17
65W8	F25-2008	65W:1037173-									*
67C7	F40-2008	67C:1035037-	*				*				
6C14	F50-2008	6C1:1018489-	*			*					
6C54	F60-2008	6C5:1024088-	*			*					
6C24	T50-2008	6C2:1006660-	*			*					
6C64	T60-2008	6C6:1008344-	*			*					
6D64	F75-2008	62P:1010402-	*		*						
6D84	F90-2008	61P:1028830-	*		*						
68V7	F115-2008	68V:1082891-	*	*							
62XE	50-2008	6H5K:1021187-	*							*	
6H37	70-2008	6H3K:1010213-	*						*		
6H1A	90-2008	6H1:1035287-	*					*			

6X4 TILLER HANDLE KIT (50-90 & F40-F115)

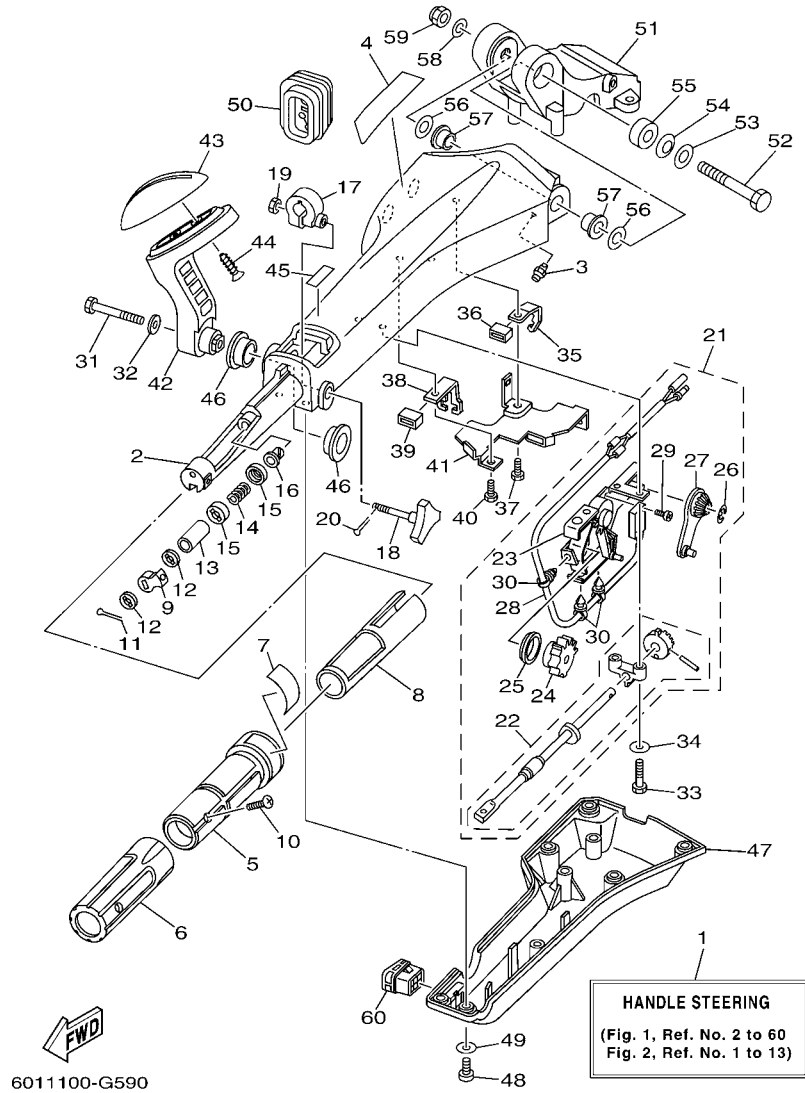

FIG. 1 BASE HANDLE - ALL

BASE MANCHE - TOUT

REF. NO.	PART NO. N° PIECES	DESCRIPTION DESCRIPTION	2008				REMARKS REMARQUES
1	6X4-42101-01	HANDLE, STEERING POIGNEE	1				LM LM
2	6X4-42111-01-4D	HANDLE, STEERING POIGNEE	1				
3	93700-06M03	NIPPLE, GREASE PION	1				
4	6X4-48215-00	GRAPHIC ADHESIF	1				
5	6X4-42119-00	GRIP, STEERING HANDLE POIGNEE, BARRE FRANCHE	1				
6	6X4-42177-00	RUBBER, HANDLE CAOUTCHOUC, POIGNEE	1				
7	6X4-42137-00	INDICATOR, THROTTLE INDICATEUR, ACCELERATION	1				
8	6X4-41291-00	BUSHING COUSSINET	1				
9	6X4-44139-00	COLLAR COLLIER	1				
10	90142-05001	SCREW, COUNTERSUNK VIS, TETE NOYEE	1				
11	91490-20010	PIN, COTTER GOUPILLE	1				
12	6X4-44177-00	WASHER RONDELLE	2				
13	6X4-42128-00	COLLAR, DISTANCE 1 COLLIER, D'ENTRETOISE 1	1				
14	90501-23215	SPRING, COMPRESSION RESSORT, COMPRESSION	1				
15	6X4-44188-00	WASHER RONDELLE	2				
16	90386-08032	BUSH DOUILLE	1				
17	63D-42126-00	FRICTION, STEERING HANDLE GRIP CUVETTE, POIGNEE DE DIRECTION	1				
18	6X4-48154-00	KNOB, THROTTLE BOUTON, ACCELERATEUR	1				
19	95380-06600	NUT, HEXAGON ECROU	1				
20	91490-20010	PIN, COTTER GOUPILLE	1				
21	6X4-44100-00	SHIFT LINK ASSY MAILLON DE SELECTEUR	1				
22	6X4-42115-00	.SHAFT, STEERING HANDLE .AXE, BARRE FRANCHE	1				
23	6X4-44102-00	.SHIFT ASSIST ASSY. .SELECTEUR DE MAINTIEN	1				
24	6X4-47731-00	.GEAR, DRIVE .PIGNON D'ENTRAINEMENT	1				
25	6X4-44132-00	.BUSHING .COUSSINET	1				
26	6X4-14137-00	.CLIP .JONC	1				
27	6X4-48261-00	.ARM, THROTTLE .BRAS, ACCELERATION	1				



6X4 TILLER HANDLE KIT (50-90 & F40-F115)

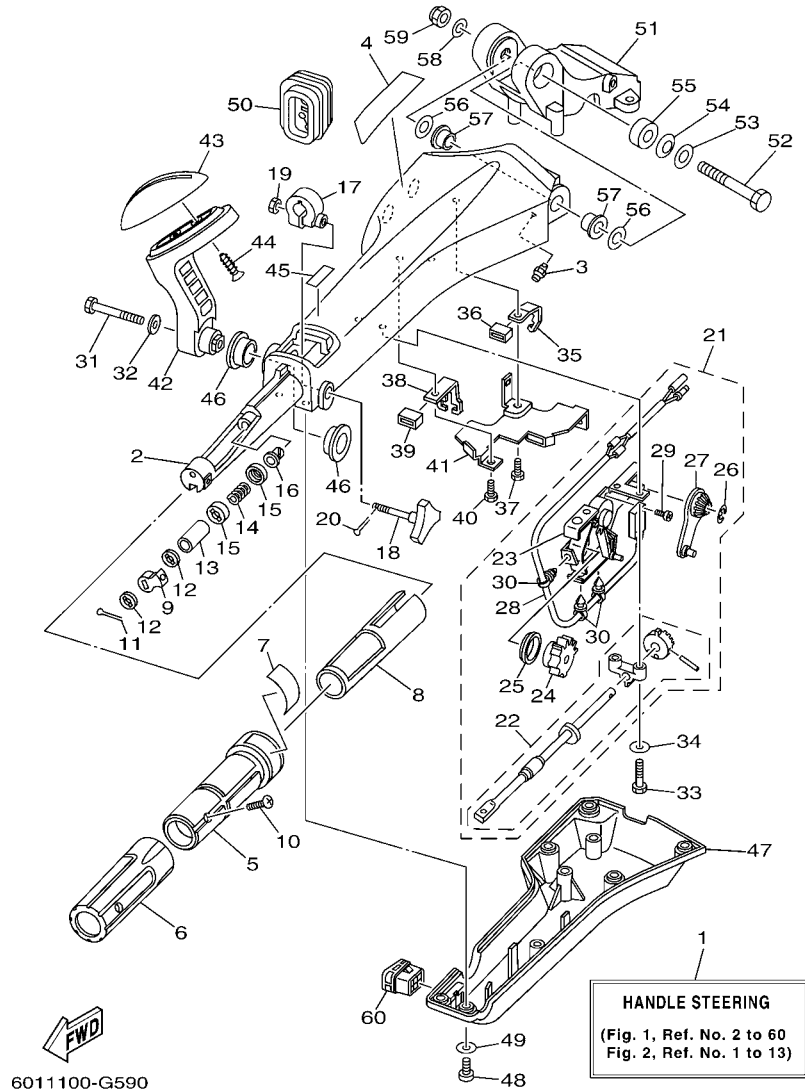

FIG. 1 BASE HANDLE - ALL

BASE MANCHE - TOUT

REF. NO.	PART NO. N° PIECES	DESCRIPTION DESCRIPTION	2008				REMARKS REMARQUES
28	6X4-82540-00	.NEUTRAL SWITCH ASSY .CONTACTEUR DE POINT-MORT	1				
29	6A5-48129-10	.SCREW 3 .VIS 3	2				
30	6X4-42821-00	.BAND, CLAMP .BRIDE, COLLIER	3				
31	97095-08040	BOLT BOULON	1				
32	92995-08600	WASHER RONDELLE	1				
33	97095-06030	BOLT BOULON	2				
34	92995-06600	WASHER RONDELLE	2				
35	6X4-48538-00	CLAMP, CABLE 1 COLLIER	1				
36	6X4-26367-00	PROTECTOR PROTECTEUR	1				
37	97095-06014	BOLT BOULON	1				
38	6X4-48538-10	CLAMP, CABLE 1 COLLIER	1				
39	6X4-26367-00	PROTECTOR PROTECTEUR	1				
40	97095-06014	BOLT BOULON	1				
41	6X4-42159-00	STAY SUPPORT	1				
42	6X4-44159-00-4D	HANDLE, GEAR SHIFT POIGNEE, LEVIER D'EMBAYAGE	1				
43	6X4-44173-00	LEVER, SHIFT CONTROL POIGNEE, INVERSION	1				
44	97780-60920	SCREW, TAPPING VIS, TETE BOMBEE	2				
45	6G8-44191-00	INDICATOR, SHIFT ETIQUETTE, EMBRAYAGE	1				
46	90386-26MA3	BUSH DOUILLE	2				
47	6X4-42131-01	COVER, HANDLE STEERING COUVERCLE	1				
48	97885-06016	SCREW, PAN HEAD VIS, A ENCOCHE	6				
49	92995-06600	WASHER RONDELLE	6				
50	6X4-42725-00	GROMMET PASSE-FIL	1				
51	63D-42121-22-4D	BRACKET SUPPORT	1				
52	90101-12014	BOLT BOULON	1				
53	92990-12200	WASHER, PLAIN RONDELLE, PLATE	1				
54	90206-12M22	WASHER, WAVE RONDELLE, ONDULEE	1				





### 6X4 TILLER HANDLE FITTING KIT (F115)

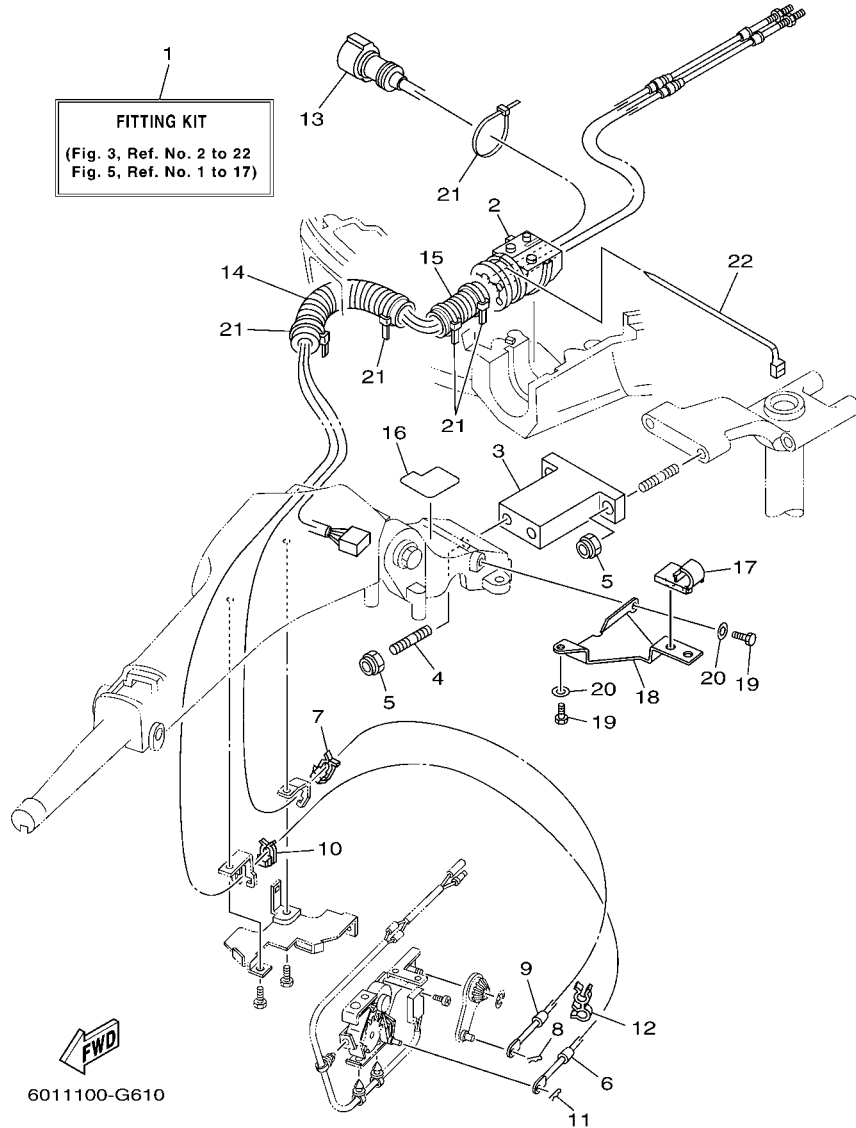

6011100-G610

FIG. 3 FITTING KIT 1

EQUIPEMENT APPROPRIE 1

REF. NO.	PART NO. N° PIECES	DESCRIPTION DESCRIPTION	2008				REMARKS REMARQUES
1	6X4-42102-00	FITTING KIT EQUIPEMENT APPROPRIE	1				LM LM
2	68V-42725-10	GROMMET PASSE-FIL	1				
3	6X4-42121-10-4D	BRACKET SUPPORT	1				
4	90116-10175	BOLT, STUD GOUJON	2				
5	90185-10051	NUT, SELF-LOCKING ECROU, AUTO-BLOQUANT	4				
6	67G-48321-20	CABLE CABLE	1				
7	63D-48538-00	CLAMP, CABLE 1 COLLIER	1				
8	90468-10005	CLIP JONC	1				
9	67G-26301-10	THROTTLE CABLE ASSY CABLE D'ACCELERATEUR	1				
10	63D-48538-00	CLAMP, CABLE 1 COLLIER	1				
11	90468-10005	CLIP JONC	1				
12	90464-09M42	CLAMP BRIDE	1				
13	6X4-82586-20	EXT. WIRE HARNESS (L: 1.25M) EXT. FAISCEAU DE FILS L: 1,25M	1				
14	90447-22007	TUBE DURITE	1				
15	6G5-83557-00	TUBE TUBE	1				
16	6X4-42735-00	PROTECTOR PROTECTEUR	1				
17	63D-24367-00	CLAMP, FUEL PIPE 2 COLLIER DE DURITE A ESSENCE	1				
18	6X4-24364-00	STAY SUPPORT	1				
19	97095-06016	BOLT BOULON	2				
20	92995-06600	WASHER RONDELLE	2				
21	90465-13M24	CLAMP BRIDE	5				
22	90465-13M30	CLAMP BRIDE	1				

### 6X4 TILLER HANDLE FITTING KIT (F75,F90)

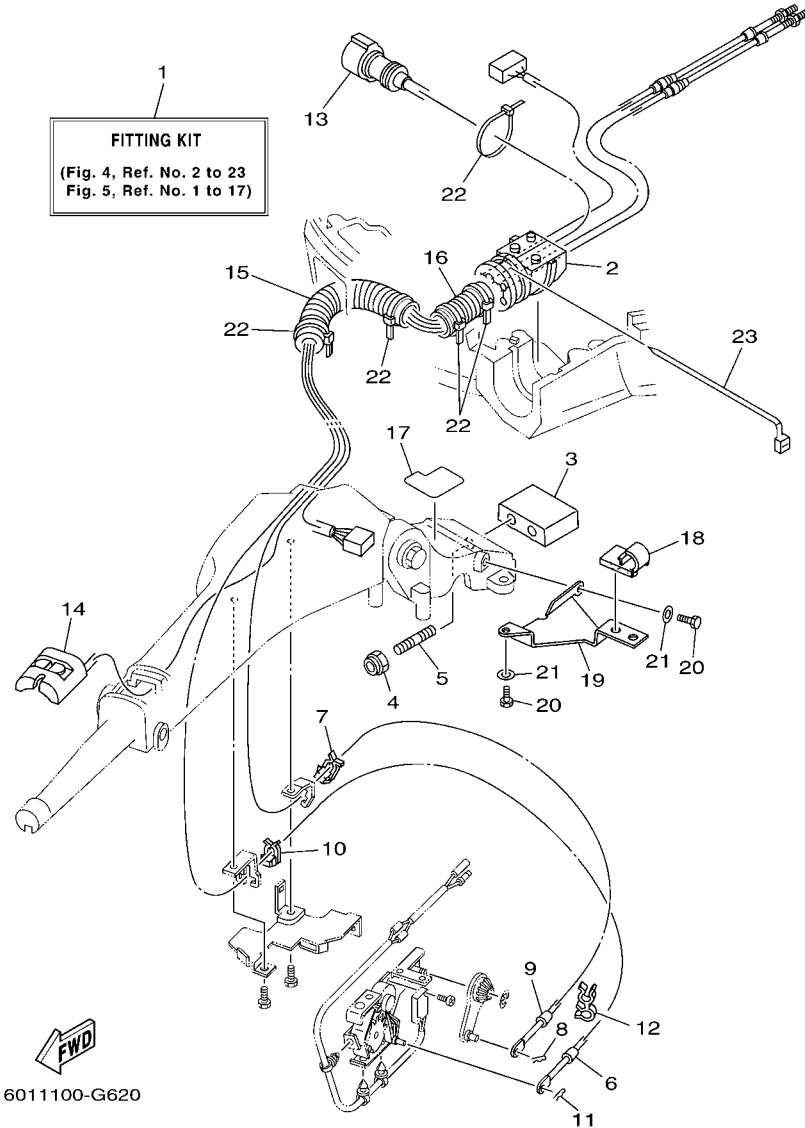

6011100-G620

FIG. 4 FITTING KIT 2

EQUIPEMENT APPROPRIE 2

REF. NO.	PART NO. N° PIECES	DESCRIPTION DESCRIPTION	2008				REMARKS REMARQUES
1	6X4-42102-10	FITTING KIT EQUIPEMENT APPROPRIE	1				LM LM
2	68V-42725-10	GROMMET PASSE-FIL	1				
3	6X4-42121-00-4D	BRACKET SUPPORT	1				
4	90185-10051	NUT, SELF-LOCKING ECROU,AUTO-BLOQUANT	2				
5	90116-10031	BOLT, STUD GOUJON	2				
6	67G-48321-20	CABLE CABLE	1				
7	63D-48538-00	CLAMP, CABLE 1 COLLIER	1				
8	90468-10005	CLIP JONC	1				
9	67G-26301-10	THROTTLE CABLE ASSY CABLE D'ACCELERATEUR	1				
10	63D-48538-00	CLAMP, CABLE 1 COLLIER	1				
11	90468-10005	CLIP JONC	1				
12	90464-09M42	CLAMP BRIDE	1				
13	6X4-82586-20	EXT. WIRE HARNESS (L: 1.25M) EXT, FAISCEAU DE FILS L: 1,25M	1				
14	6X4-81860-00	SWITCH ASSY COMMUTATEUR COMPLET	1				
15	90447-22007	TUBE DURITE	1				
16	6K3-83557-00	TUBE TUBE	1				
17	6X4-42735-00	PROTECTOR PROTECTEUR	1				
18	63D-24367-00	CLAMP, FUEL PIPE 2 COLLIER DE DURITE A ESSENCE	1				
19	6X4-24364-00	STAY SUPPORT	1				
20	97095-06016	BOLT BOULON	2				
21	92995-06600	WASHER RONDELLE	2				
22	90465-13M24	CLAMP BRIDE	5				
23	90465-13M30	CLAMP BRIDE	1				

6X4 TILLER HANDLE FITTING KIT  
STEERING FRICTION (F75,F90,F115)

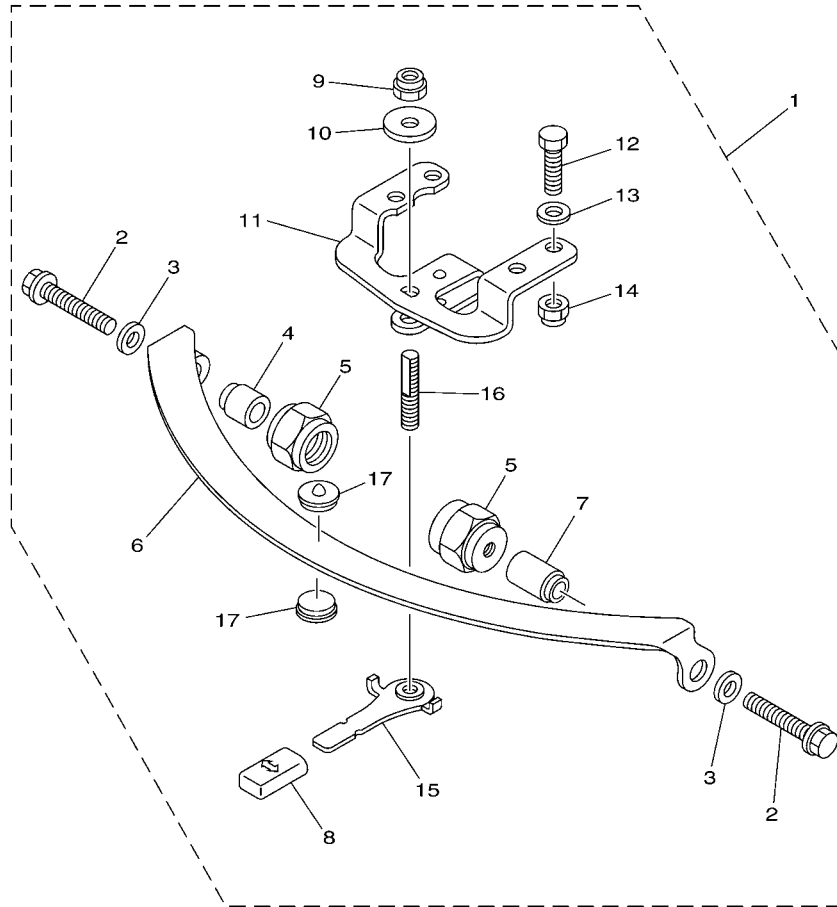

6011100-G630

FIG. 5 STEERING FRICTION 1

CUVETTE POIGNEE DE DIRECTION 1

REF. NO.	PART NO. N° PIECES	DESCRIPTION DESCRIPTION	2008				REMARKS REMARQUES
1	67G-42508-10	STEERING FRICTION ASSY DIRECTION FRICTION (ENS.)	1				
2	90119-08M74	.BOLT, WITH WASHER .BOULON, AVEC RONDELLE	2				
3	90201-08M01	.WASHER, PLATE .RONDELLE, PLATE	2				
4	67G-42541-00	.PIPE 1 .TUYAU 1	1				
5	67G-42546-00	.NUT .ECROU	2				
6	63D-42527-00	.PLATE, FRICTION .PLAQUE, FRICTION	1				
7	67G-42541-10	.PIPE 1 .TUYAU 1	1				
8	682-43318-01	.COVER .CAPUCHON	1				
9	90185-10M14	.NUT, SELF-LOCKING .ECROU,AUTO-BLOQUANT	1				
10	90201-10M76	.WASHER, PLATE .RONDELLE, PLATE	1				
11	6X4-42526-00	.PLATE, FRICTION .PLAQUE, FRICTION	1				
12	97095-08025	.BOLT .BOULON	2				
13	92995-08600	.WASHER .RONDELLE	2				
14	90185-08057	.NUT, SELF-LOCKING .ECROU,AUTO-BLOQUANT	2				
15	67G-42561-00	.KNOB, STEERING LOCK .BOUTON	1				
16	67G-42562-00	.SHAFT, STEERING LOCK .ARBRE,ANTIVOL DE DIRECTION	1				
17	63D-42528-00	.PLATE, FRICTION .PLAQUE, FRICTION	2				



**6X4 TILLER HANDLE FITTING KIT  
STEERING FRICTION (F50, T50, F60, T60)**

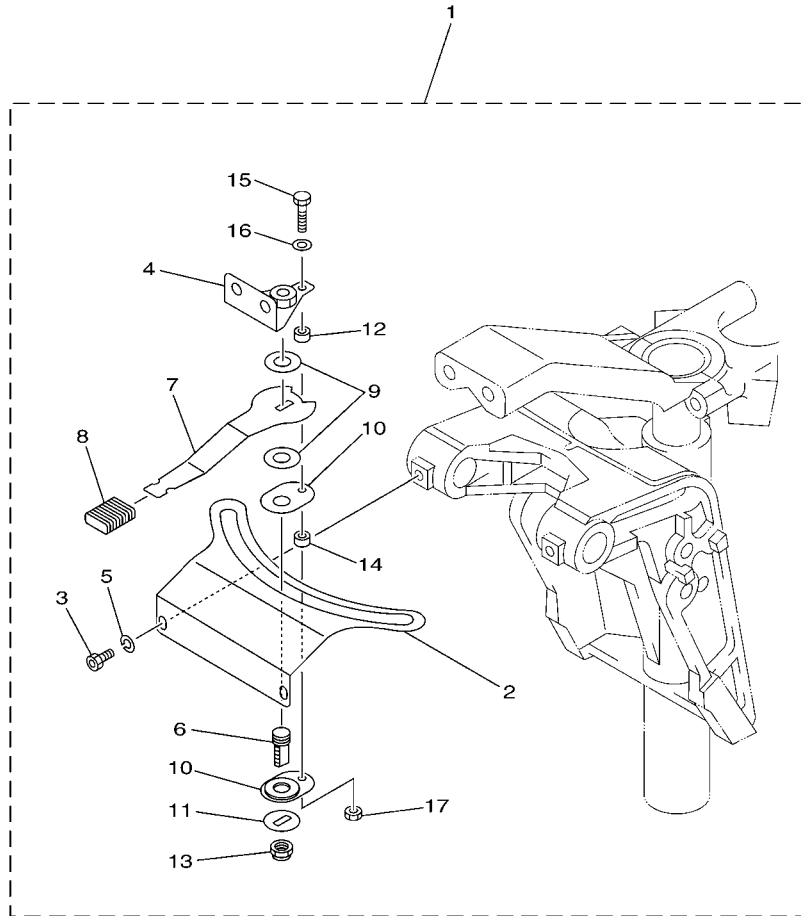

6011100-G650

**FIG. 7 STEERING FRICTION 2**

**CUVETTE POIGNEE DE DIRECTION 2**

REF. NO.	PART NO. N° PIECES	DESCRIPTION DESCRIPTION	2008				REMARKS REMARQUES
1	6C5-42508-00	STEERING FRICTION ASSY DIRECTION FRICTION (ENS.)	1				
2	6C5-42527-00	.PLATE, FRICTION .PLAQUE, FRICTION	1				
3	90109-06M88	.BOLT .BOULON	2				
4	67C-42525-00	.PLATE, FRICTION .PLAQUE, FRICTION	1				
5	92990-06100	.WASHER, SPRING .RONDELLE, GROWER	2				
6	67C-42562-00	.SHAFT, STEERING LOCK .ARBRE, ANTIVOL DE DIRECTION	1				
7	67C-42561-00	.KNOB, STEERING LOCK .BOUTON	1				
8	689-43633-00	.COVER, TILT LEVER .COUVERCLE	1				
9	90202-10M56	.WASHER, PLATE .RONDELLE, PLATE	2				
10	65W-42528-00	.PLATE, FRICTION .PLAQUE, FRICTION	2				
11	90209-10M26	.WASHER .RONDELLE	1				
12	90387-05M05	.COLLAR .COLLERETTE	1				
13	90185-10M14	.NUT, SELF-LOCKING .ECROU, AUTO-BLOQUANT	1				
14	90387-05M11	.COLLAR .COLLERETTE	1				
15	97095-05020	.BOLT .BOULON	1				
16	92995-05600	.WASHER .RONDELLE	1				
17	95380-05600	.NUT .ECROU	1				





6X4 TILLER HANDLE FITTING KIT  
STEERING FRICTION (F40)

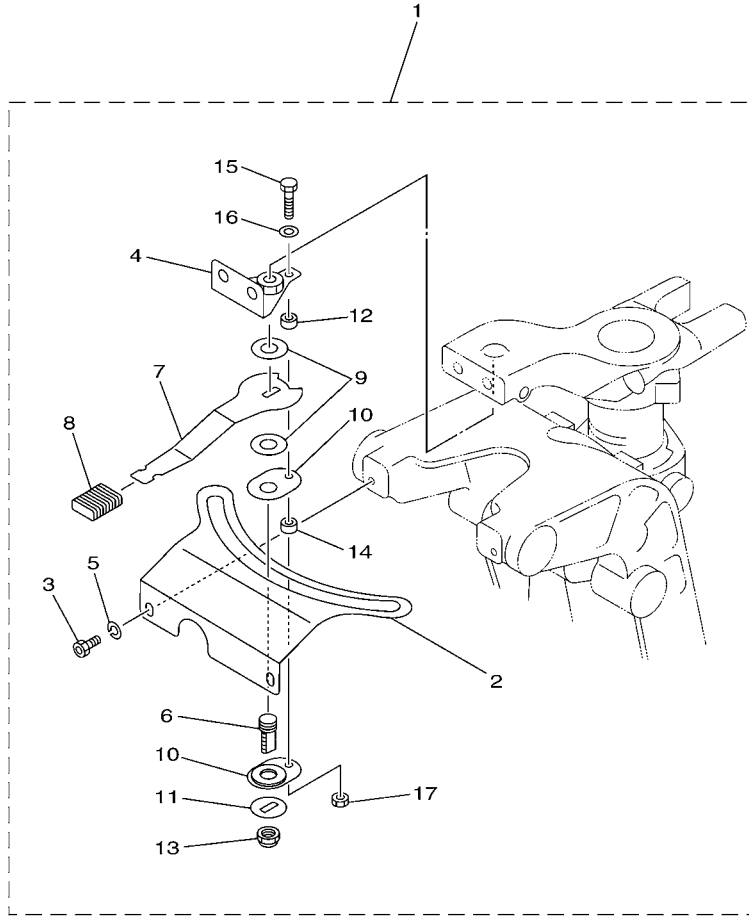

6011100-G670

FIG. 9 STEERING FRICTION 3

CUVETTE POIGNEE DE DIRECTION 3

REF. NO.	PART NO. N° PIECES	DESCRIPTION DESCRIPTION	2008				REMARKS REMARQUES
1	67C-42508-03	STEERING FRICTION ASSY DIRECTION FRICTION (ENS.)	1				
2	67C-42527-03	.PLATE, FRICTION .PLAQUE, FRICTION	1				
3	90109-06M88	.BOLT .BOULON	2				
4	67C-42525-00	.PLATE, FRICTION .PLAQUE, FRICTION	1				
5	92990-06100	.WASHER, SPRING .RONDELLE, GROWER	2				
6	67C-42562-00	.SHAFT, STEERING LOCK .ARBRE, ANTIVOL DE DIRECTION	1				
7	67C-42561-00	.KNOB, STEERING LOCK .BOUTON	1				
8	689-43633-00	.COVER, TILT LEVER .COUVERCLE	1				
9	90202-10M56	.WASHER, PLATE .RONDELLE, PLATE	2				
10	65W-42528-00	.PLATE, FRICTION .PLAQUE, FRICTION	2				
11	90209-10M26	.WASHER .RONDELLE	1				
12	90387-05M05	.COLLAR .COLLERETTE	1				
13	90185-10M14	.NUT, SELF-LOCKING .ECROU, AUTO-BLOQUANT	1				
14	90387-05M11	.COLLAR .COLLERETTE	1				
15	97095-05020	.BOLT .BOULON	1				
16	92995-05600	.WASHER .RONDELLE	1				
17	95380-05600	.NUT .ECROU	1				

### 6X4 TILLER HANDLE FITTING KIT (90)

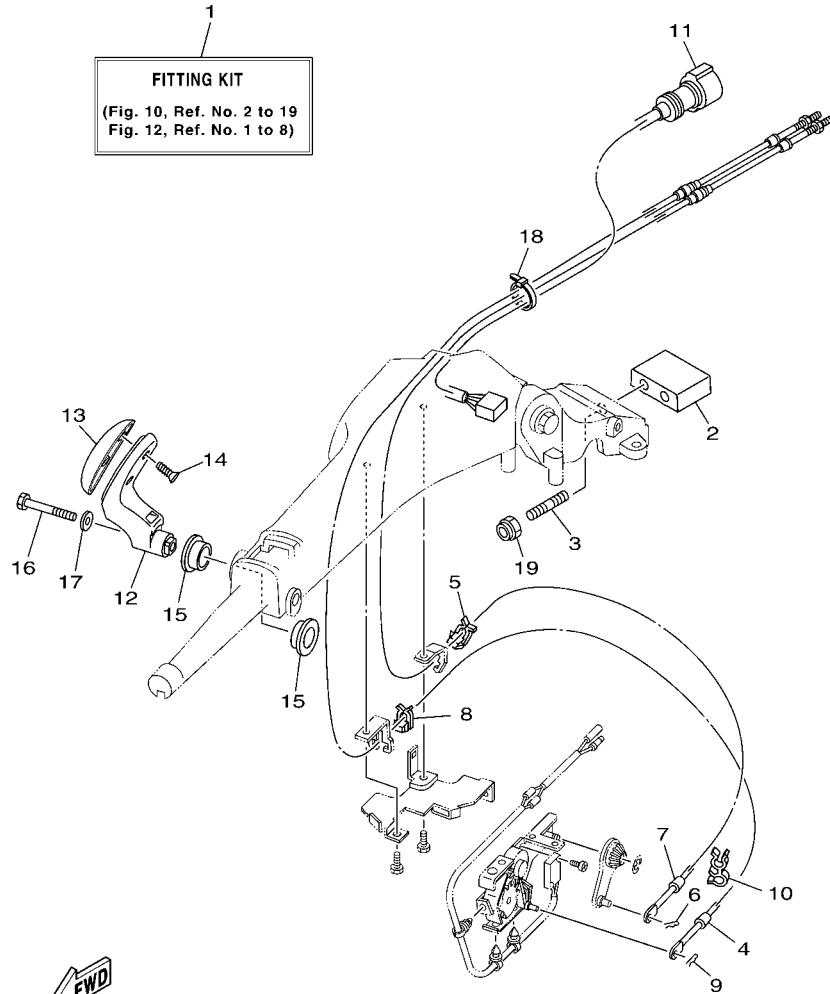

6011100-G680

FIG. 10 FITTING KIT 5

EQUIPEMENT APPROPRIE 5

REF. NO.	PART NO. N° PIECES	DESCRIPTION DESCRIPTION	2008				REMARKS REMARQUES
1	6X4-42102-41	FITTING KIT EQUIPEMENT APPROPPIE	1				LM LM
2	6X4-42121-00-4D	BRACKET SUPPORT	1				
3	90116-10031	BOLT, STUD GOUJON	2				
4	6H1-48321-11	CABLE CABLE	1				
5	63D-48538-00	CLAMP, CABLE 1 COLLIER	1				
6	90468-10005	CLIP JONC	1				
7	6H1-26301-01	THROTTLE CABLE ASSY CABLE D'ACCELERATEUR	1				
8	63D-48538-00	CLAMP, CABLE 1 COLLIER	1				
9	90468-10005	CLIP JONC	1				
10	90464-09M42	CLAMP BRIDE	1				
11	6X4-82586-30	EXTENSION, WIRE HARNESS EXTENSION, FAISCEAU DE FILS	1				
12	6X4-44159-10-4D	HANDLE, GEAR SHIFT POIGNEE, LEVIER D'EMBAYAGE	1				
13	6X4-44173-00	LEVER, SHIFT CONTROL POIGNEE, INVERSION	1				
14	97780-60920	SCREW, TAPPING VIS, TETE BOMBEE	2				
15	90386-26MA3	BUSH DOUILLE	1				
16	97095-08040	BOLT BOULON	1				
17	92995-08600	WASHER RONDELLE	1				
18	90465-13M36	CLAMP BRIDE	1				
19	90185-10051	NUT, SELF-LOCKING ECROU, AUTO-BLOQUANT	2				

### 6X4 TILLER HANDLE FITTING KIT (70)

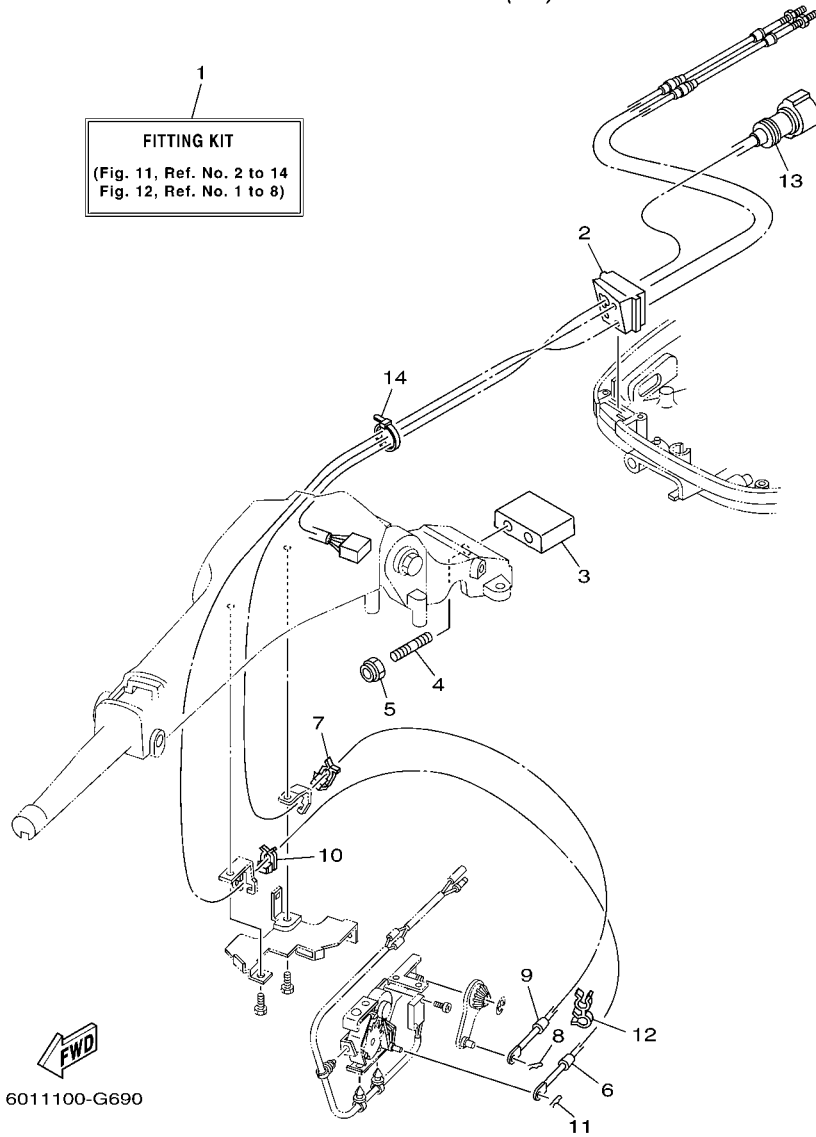

6011100-G690

FIG. 11 FITTING KIT 6

EQUIPEMENT APPROPRIE 6

REF. NO.	PART NO. N° PIECES	DESCRIPTION DESCRIPTION	2008				REMARKS REMARQUES
1	6X4-42102-51	FITTING KIT EQUIPEMENT APPROPRIE	1				LM LM
2	6H3-42725-30	GROMMET PASSE-FIL	1				
3	6X4-42121-00-4D	BRACKET SUPPORT	1				
4	90116-10031	BOLT, STUD GOUJON	2				
5	90185-10051	NUT, SELF-LOCKING ECROU, AUTO-BLOQUANT	2				
6	6H3-48321-11	CABLE CABLE	1				
7	63D-48538-00	CLAMP, CABLE 1 COLLIER	1				
8	90468-10005	CLIP JONC	1				
9	6H3-26301-01	THROTTLE CABLE ASSY CABLE D'ACCELERATEUR	1				
10	63D-48538-00	CLAMP, CABLE 1 COLLIER	1				
11	90468-10005	CLIP JONC	1				
12	90464-09M42	CLAMP BRIDE	1				
13	6X4-82586-30	EXTENSION, WIRE HARNESS EXTENSION, FAISCEAU DE FILS	1				
14	90465-13M36	CLAMP BRIDE	1				





6X4 TILLER HANDLE FITTING KIT  
STEERING FRICTION (50)

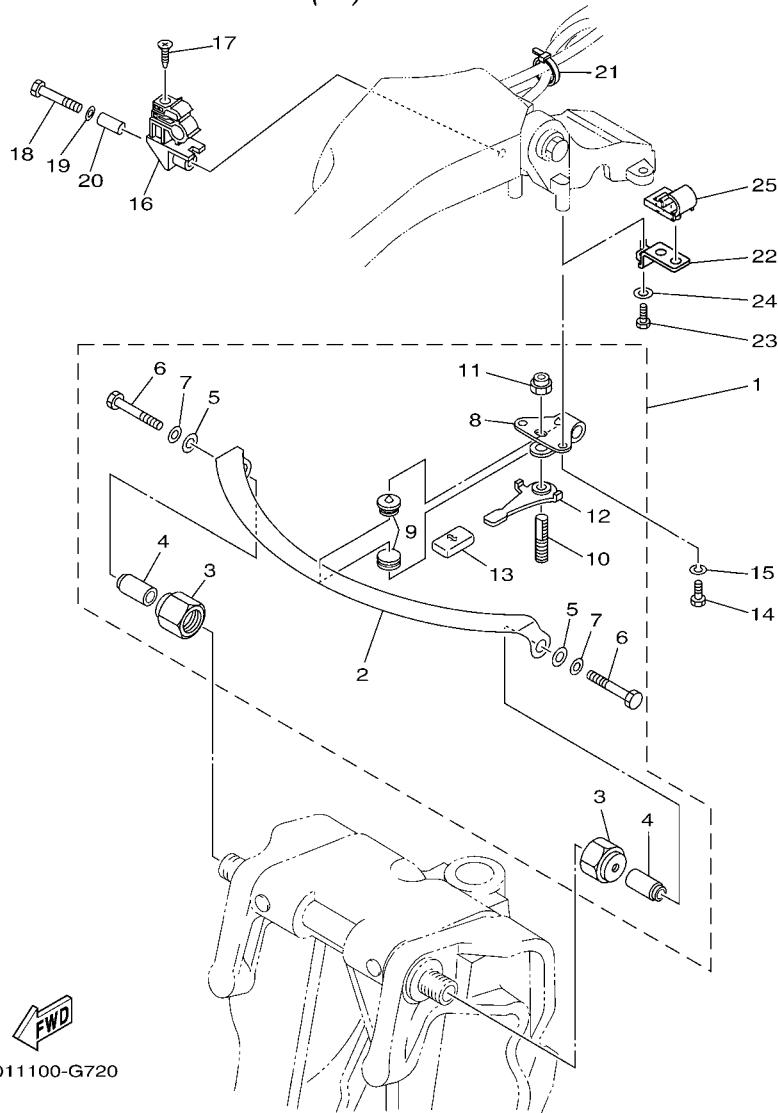

6011100-G720

FIG. 14 STEERING FRICTION 5

CUVETTE POIGNEE DE DIRECTION 5

REF. NO.	PART NO. N° PIECES	DESCRIPTION DESCRIPTION	2008			REMARKS REMARQUES
1	63D-42508-00	STEERING FRICTION ASSY DIRECTION FRICTION (ENS.)	1			
2	63D-42527-00	.PLATE, FRICTION .PLAQUE, FRICTION	1			
3	63D-42546-00	.NUT .ECROU	2			
4	63D-42541-00	.PIPE 1 .TUYAU 1	2			
5	90201-08M01	.WASHER, PLATE .RONDELLE, PLATE	2			
6	97095-08050	.BOLT .BOULON	2			
7	92990-08600	.WASHER, PLATE .RONDELLE, PLATE	2			
8	63D-42526-00	.PLATE, FRICTION .PLAQUE, FRICTION	1			
9	63D-42528-00	.PLATE, FRICTION .PLAQUE, FRICTION	2			
10	63D-42562-00	.SHAFT, STEERING LOCK .ARBRE, ANTIVOL DE DIRECTION	1			
11	90185-10M01	.NUT, SELF-LOCKING .ECROU, AUTO-BLOQUANT	1			
12	63D-42561-00	.KNOB, STEERING LOCK .BOUTON	1			
13	682-43318-01	.COVER .CAPUCHON	1			
14	97095-06016	BOLT BOULON	2			
15	92995-06100	WASHER, SPRING RONDELLE, GROWER	2			
16	63D-82361-00	CLAMP, CORD COLLIER, CORDON	1			
17	90161-06M00	SCREW, TAPPING VIS, TETE FRAISEE	1			
18	97095-06035	BOLT BOULON	1			
19	92995-06600	WASHER RONDELLE	1			
20	90387-06M26	COLLAR COLLERETTE	1			
21	90465-13M36	CLAMP BRIDE	1			
22	63D-24364-10	STAY SUPPORT	1			
23	97095-06016	BOLT BOULON	1			
24	92995-06600	WASHER RONDELLE	1			
25	63D-24367-00	CLAMP, FUEL PIPE 2 COLLIER DE DURITE A ESSENCE	1			

6X4 TILLER HANDLE COMPLETE (F25)

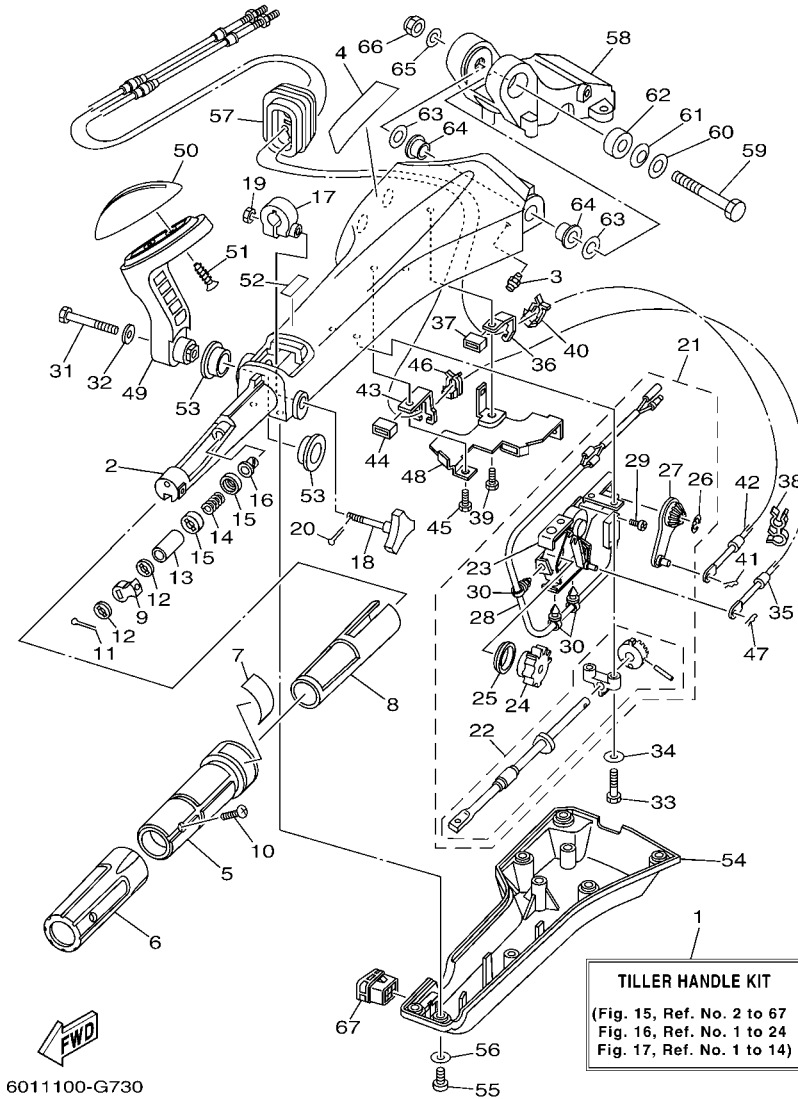

FIG. 15 TILLER HANDLE KIT 1

POCHETTE DE BARRE FRANCHE 1

REF. NO.	PART NO. N° PIECES	DESCRIPTION DESCRIPTION	2008			REMARKS REMARQUES
1	6X4-42103-02	TILLER HANDLE KIT POCHETTE DE BARRE FRANCHE	1			LM LM
2	6X4-42111-01-4D	HANDLE, STEERING POIGNEE	1			
3	93700-06M03	NIPPLE, GREASE PION	1			
4	6X4-48215-00	GRAPHIC ADHESIF	1			
5	6X4-42119-00	GRIP, STEERING HANDLE POIGNEE, BARRE FRANCHE	1			
6	6X4-42177-00	RUBBER, HANDLE CAOUTCHOUC, POIGNEE	1			
7	6X4-42137-00	INDICATOR, THROTTLE INDICATEUR, ACCELERATION	1			
8	6X4-41291-00	BUSHING COUSSINET	1			
9	6X4-44139-00	COLLAR COLLIER	1			
10	90142-05001	SCREW, COUNTERSUNK VIS, TETE NOYEE	1			
11	91490-20010	PIN, COTTER GOUPILLE	1			
12	6X4-44177-00	WASHER RONDELLE	2			
13	6X4-42128-00	COLLAR, DISTANCE 1 COLLIER, D'ENTRETOISE 1	1			
14	90501-23215	SPRING, COMPRESSION RESSORT, COMPRESSION	1			
15	6X4-44188-00	WASHER RONDELLE	2			
16	90386-08032	BUSH DOUILLE	1			
17	63D-42126-00	FRICION, STEERING HANDLE GRIP CUVETTE, POIGNEE DE DIRECTION	1			
18	6X4-48154-00	KNOB, THROTTLE BOUTON, ACCELERATEUR	1			
19	95380-06600	NUT, HEXAGON ECROU	1			
20	91490-20010	PIN, COTTER GOUPILLE	1			
21	6X4-44100-00	SHIFT LINK ASSY MAILLON DE SELECTEUR	1			
22	6X4-42115-00	.SHAFT, STEERING HANDLE .AXE, BARRE FRANCHE	1			
23	6X4-44102-00	.SHIFT ASSIST ASSY. .SELECTEUR DE MAINTIEN	1			
24	6X4-47731-00	.GEAR, DRIVE .PIGNON D'ENTRAINEMENT	1			
25	6X4-44132-00	.BUSHING .COUSSINET	1			
26	6X4-14137-00	.CLIP .JONC	1			
27	6X4-48261-00	.ARM, THROTTLE .BRAS, ACCELERATION	1			



6X4 TILLER HANDLE COMPLETE (F25)

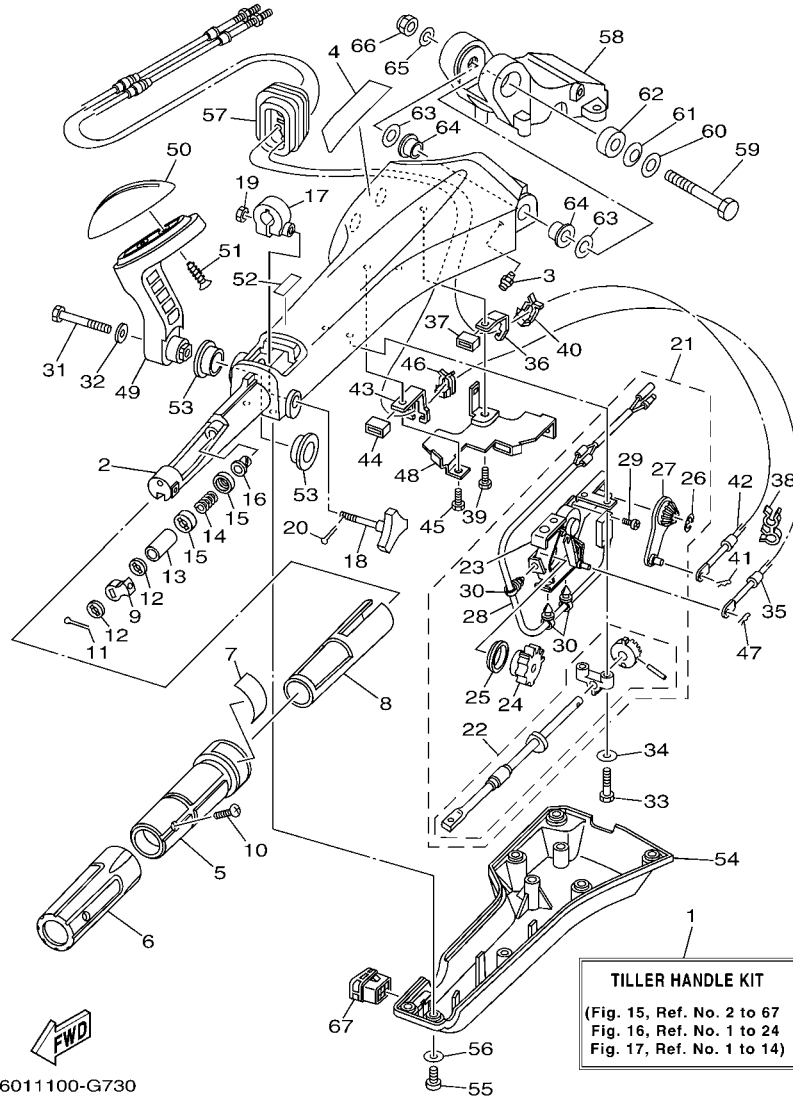

FIG. 15 TILLER HANDLE KIT 1

POCHETTE DE BARRE FRANCHE 1

REF. NO.	PART NO. N° PIECES	DESCRIPTION DESCRIPTION	2008				REMARKS REMARQUES
28	6X4-82540-00	.NEUTRAL SWITCH ASSY .CONTACTEUR DE POINT-MORT	1				
29	6A5-48129-10	.SCREW 3 .VIS 3	2				
30	6X4-42821-00	.BAND, CLAMP .BRIDE, COLLIER	3				
31	97095-08040	BOLT BOULON	1				
32	92995-08600	WASHER RONDELLE	1				
33	97095-06030	BOLT BOULON	2				
34	92995-06600	WASHER RONDELLE	2				
35	6H1-48321-21	CABLE CABLE	1				
36	6X4-48538-00	CLAMP, CABLE 1 COLLIER	1				
37	6X4-26367-00	PROTECTOR PROTECTEUR	1				
38	90464-09M42	CLAMP BRIDE	1				
39	97095-06014	BOLT BOULON	1				
40	63D-48538-00	CLAMP, CABLE 1 COLLIER	1				
41	90468-10005	CLIP JONC	1				
42	6H3-48321-02	CABLE CABLE	1				
43	6X4-48538-10	CLAMP, CABLE 1 COLLIER	1				
44	6X4-26367-00	PROTECTOR PROTECTEUR	1				
45	97095-06014	BOLT BOULON	1				
46	63D-48538-00	CLAMP, CABLE 1 COLLIER	1				
47	90468-10005	CLIP JONC	1				
48	6X4-42159-00	STAY SUPPORT	1				
49	6X4-44159-00-4D	HANDLE, GEAR SHIFT POIGNEE, LEVIER D'EMBAYAGE	1				
50	6X4-44173-00	LEVER, SHIFT CONTROL POIGNEE, INVERSION	1				
51	97780-60920	SCREW, TAPPING VIS, TETE BOMBEE	2				
52	6G8-44191-00	INDICATOR, SHIFT ETIQUETTE, EMBRAYAGE	1				
53	90386-26MA3	BUSH DOUILLE	2				
54	6X4-42131-01	COVER, HANDLE STEERING COUVERCLE	1				



6X4 TILLER HANDLE COMPLETE (F25)

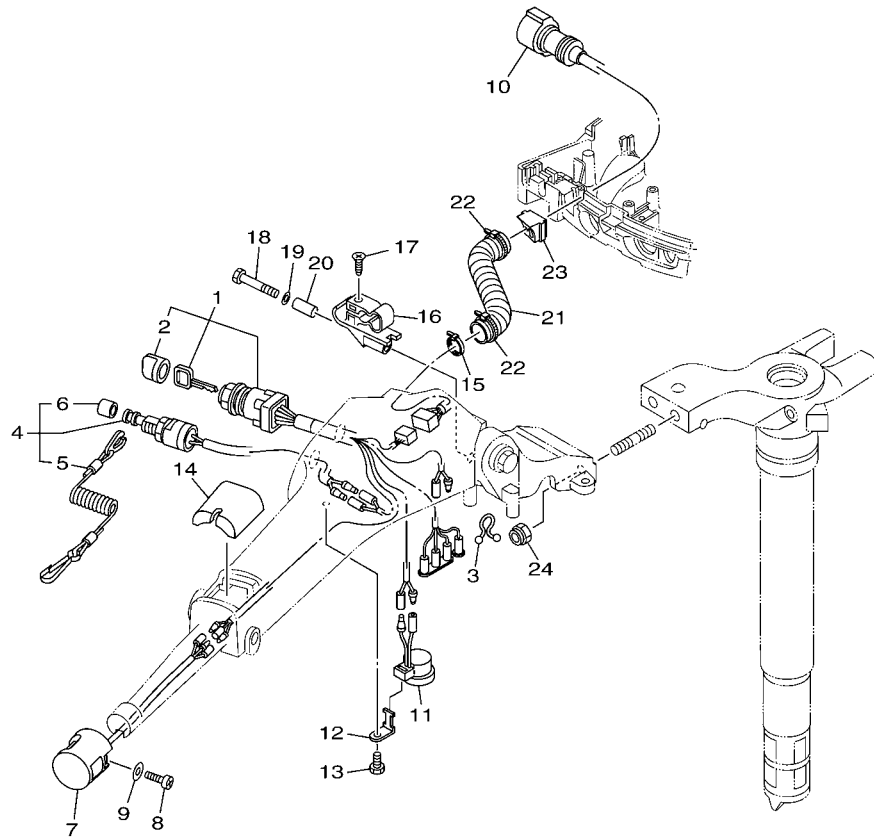

  
6011100-G740

FIG. 16 TILLER HANDLE KIT 2

POCHETTE DE BARRE FRANCHE 2

REF. NO.	PART NO. N° PIECES	DESCRIPTION DESCRIPTION	2008				REMARKS REMARQUES
1	6X4-82510-00	MAIN SWITCH ASSY CONTACTEUR A CLEF COMPLET	1				
2	676-82577-00	.CAP, KEY .CABOCHON	1				
3	90464-08M07	CLAMP BRIDE	1				
4	69W-82575-00	ENGINE STOP SWITCH ASSY COUPE CIRCUIT CPLT	1				
5	682-82556-00	.LANYARD, STOP SWITCH .PLAQUETTE	1				
6	689-8257Y-00	.CAP .CHAPEAU	1				
7	6X4-82563-00	TRIM & TILT SWITCH ASSY INCLINER ET PARER COMMUTATEUR	1				
8	97880-06016	SCREW, PAN HEAD VIS, TETE TRONCONIQUE	1				
9	92990-06600	WASHER, PLATE RONDELLE, PLATE	1				
10	6X4-82586-10	EXT., WIRE HARNESS (L: 950MM) EXT.; FAISCEAU DE FILS L: 950MM	1				
11	6X4-83383-00	BUZZER RONFLEUR	1				
12	6X4-83386-00	STAY, BUZZER SUPPOR, RONFLEUR	1				
13	97095-06014	BOLT BOULON	1				
14	6X4-81942-00	COVER COUVERCLE	1				
15	90465-13M36	CLAMP BRIDE	1				
16	62Y-82361-00	CLAMP, CORD COLLIER, CORDON	1				
17	90161-06M03	SCREW, TAPPING VIS, TETE FRAISEE	1				
18	97095-06035	BOLT BOULON	1				
19	92995-06600	WASHER RONDELLE	1				
20	90387-06M26	COLLAR COLLERETTE	1				
21	90447-22006	TUBE DURITE	1				
22	90465-13M24	CLAMP BRIDE	2				
23	65W-42725-21	GROMMET PASSE-FIL	1				
24	90185-10051	NUT, SELF-LOCKING ECROU, AUTO-BLOQUANT	2				

6X4 TILLER HANDLE COMPLETE  
STEERING FRICTION (F25)

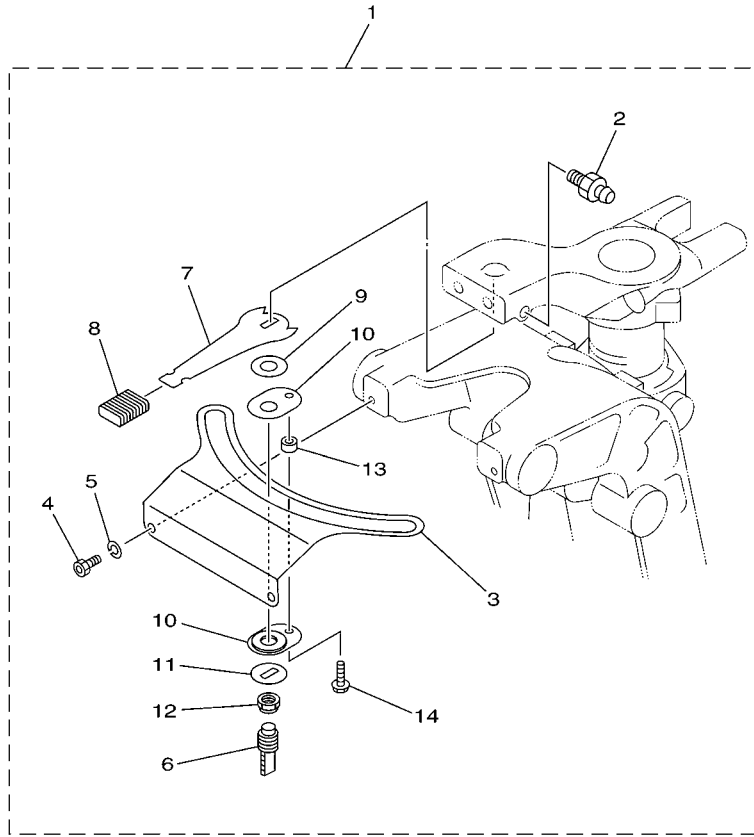

6011100-G750

FIG. 17 TILLER HANDLE KIT 3

POCHETTE DE BARRE FRANCHE 3

REF. NO.	PART NO. N° PIECES	DESCRIPTION DESCRIPTION	2008				REMARKS REMARQUES
1	65W-42508-00	STEERING FRICTION ASSY DIRECTION FRICTION (ENS.)	1				
2	93700-06M03	.NIPPLE, GREASE .PION	1				
3	65W-42527-00	.PLATE, FRICTION .PLAQUE, FRICTION	1				
4	90109-06M88	.BOLT .BOULON	2				
5	92990-06100	.WASHER, SPRING .RONDELLE, GROWER	2				
6	65W-42562-00	.SHAFT, STEERING LOCK .ARBRE, ANTIVOL DE DIRECTION	1				
7	65W-42561-00	.KNOB, STEERING LOCK .BOUTON	1				
8	689-43633-00	.COVER, TILT LEVER .COUVERCLE	1				
9	90202-10M56	.WASHER, PLATE .RONDELLE, PLATE	1				
10	65W-42528-00	.PLATE, FRICTION .PLAQUE, FRICTION	2				
11	90209-10M26	.WASHER .RONDELLE	1				
12	90185-10M14	.NUT, SELF-LOCKING .ECROU, AUTO-BLOQUANT	1				
13	90387-05M11	.COLLAR .COLLERETTE	1				
14	90109-05M89	.BOLT .BOULON	1				

# STEERING FRICTION

Part No.	Applicable model
6AH-42508-00	F13.5B, F15C (F15), F20B (F20) MT
6AH-42508-10	F13.5B, F15C (F15), F20B (F20) PT

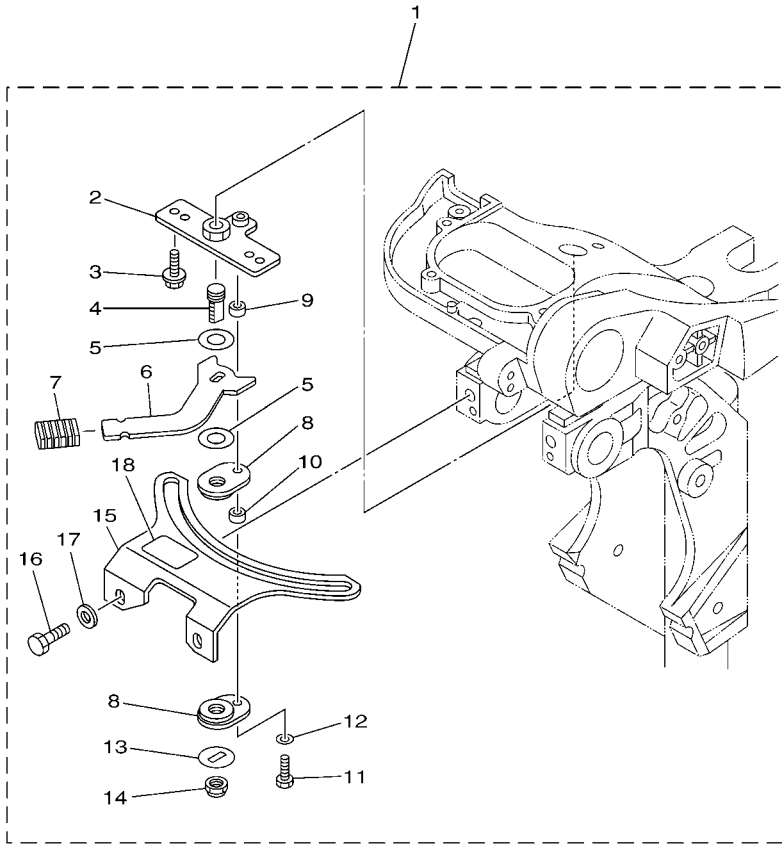

6011100-G760

## FIG. 18 STEERING FRICTION 6

## CUVETTE POIGNEE DE DIRECTION 6

REF. NO.	PART NO. N° PIECES	DESCRIPTION DESCRIPTION	2008				REMARKS REMARQUES
1	6AH-42508-00	STEERING FRICTION ASSY DIRECTION FRICTION (ENS.)	1				UR
	6AH-42508-10	STEERING FRICTION ASSY DIRECTION FRICTION (ENS.)	1				UR
2	68T-42525-01	.PLATE, FRICTION .PLAQUE, FRICTION	1				UR
3	90119-05018	.BOLT, WITH WASHER .BOULON, AVEC RONDELLE	2				UR
4	67C-42562-00	.SHAFT, STEERING LOCK .ARBRE, ANTIVOL DE DIRECTION	1				
5	90202-10M56	.WASHER, PLATE .RONDELLE, PLATE	2				
6	68T-42561-00	.KNOB, STEERING LOCK .BOUTON	1				
7	689-43633-00	.COVER, TILT LEVER .COUVERCLE	1				
8	65W-42528-00	.PLATE, FRICTION .PLAQUE, FRICTION	2				
9	90387-05M05	.COLLAR .COLLERETTE	1				
10	90387-05M11	.COLLAR .COLLERETTE	1				
11	97095-05020	.BOLT .BOULON	1				
12	92995-05600	.WASHER .RONDELLE	1				
13	90209-10M26	.WASHER .RONDELLE	1				
14	90185-10M14	.NUT, SELF-LOCKING .ECROU, AUTO-BLOQUANT	1				
15	6AH-42527-00	.PLATE, FRICTION .PLAQUE, FRICTION	1				
16	90101-08022	.BOLT .BOULON	2				
17	90201-08065	.WASHER, PLATE .RONDELLE, PLATE	2				
18	68T-43155-00	.MARK 1 .ETIQUETTE 1	1				FOR 6AH-42508-00 FOR 6AH-42508-00

NUMERICAL INDEX  
INDEX NUMERIQUE

PART NO. N° PIECES	REF. NO.	PART NO. N° PIECES	REF. NO.	PART NO. N° PIECES	REF. NO.	PART NO. N° PIECES	REF. NO.	PART NO. N° PIECES	REF. NO.	PART NO. N° PIECES	REF. NO.
6X4-14137-00	1 - 26	6X4-42137-00	1 - 7	67C-42562-00	9 - 6	6A5-48129-10	15 - 29	6X4-82563-00	2 - 7	90185-10051	13 - 3
	15 - 26		15 - 7		18 - 4	6X4-48154-00	1 - 18		16 - 7		16 - 24
6X4-24364-00	3 - 18	6X4-42159-00	1 - 41	67G-42562-00	5 - 16		15 - 18	69W-82575-00	2 - 4	90185-10M01	14 - 11
	4 - 19		15 - 48	6H4-42724-20	13 - 2	6X4-48215-00	1 - 4		16 - 4	90185-10M14	5 - 9
63D-24364-10	14 - 22	6X4-42177-00	1 - 6	6X4-42725-00	1 - 50		15 - 4	676-82577-00	2 - 2		7 - 13
63D-24367-00	3 - 17		15 - 6		15 - 57	6X4-48261-00	1 - 27		16 - 2		9 - 13
	4 - 18	63D-42508-00	14 - 1	68V-42725-10	3 - 2		15 - 27	689-8257Y-00	2 - 6		17 - 12
	14 - 25	65W-42508-00	17 - 1		4 - 2	6H3-48321-02	15 - 42		16 - 6		18 - 14
69W-26301-00	6 - 7	6AH-42508-00	18 - 1	65W-42725-21	16 - 23	63D-48321-11	13 - 4	6X4-82586-00	8 - 11	90185-12M12	1 - 59
	8 - 7	6C5-42508-00	7 - 1	62Y-42725-30	8 - 2	67C-48321-11	6 - 4		13 - 11		15 - 66
63D-26301-01	13 - 7	692-42508-01	12 - 1	6C5-42725-30	6 - 2		8 - 4	6X4-82586-10	6 - 11	90201-08065	18 - 17
6H1-26301-01	10 - 7	67C-42508-03	9 - 1	6H3-42725-30	11 - 2	6H1-48321-11	10 - 4		16 - 10	90201-08M01	5 - 3
6H3-26301-01	11 - 9	67G-42508-10	5 - 1	6X4-42728-10	1 - 60	6H3-48321-11	11 - 6	6X4-82586-20	3 - 13		14 - 5
67G-26301-10	3 - 9	6AH-42508-10	18 - 1		15 - 67	67G-48321-20	3 - 6		4 - 13	90201-10M76	5 - 10
	4 - 9	692-42515-01	12 - 6	6X4-42735-00	3 - 16		4 - 6	6X4-82586-30	10 - 11	90201-12035	1 - 56
6X4-26367-00	1 - 36	663-42518-00	12 - 2		4 - 17	6H1-48321-21	15 - 35		11 - 13		15 - 63
	1 - 39	67C-42525-00	7 - 4	6X4-42821-00	1 - 30	63D-48538-00	3 - 7	6X4-83383-00	2 - 10	90202-10M56	7 - 9
	15 - 37		9 - 4		15 - 30		3 - 10		16 - 11		9 - 9
	15 - 44	68T-42525-01	18 - 2	68T-43155-00	18 - 18		4 - 7	6X4-83386-00	2 - 11		17 - 9
6X4-41291-00	1 - 8	63D-42526-00	14 - 8	682-43318-01	5 - 8		4 - 10		16 - 12		18 - 5
	15 - 8	6X4-42526-00	5 - 11		14 - 13		6 - 5	6G5-83557-00	3 - 15	90206-12M22	1 - 54
6X4-42101-01	1 - 1	63D-42527-00	5 - 6	689-43633-00	7 - 8		6 - 8	6K3-83557-00	4 - 16		15 - 61
6X4-42102-00	3 - 1		14 - 2		9 - 8		8 - 5	90101-08022	18 - 16	90209-10M26	7 - 11
6X4-42102-10	4 - 1	65W-42527-00	17 - 3		17 - 8		8 - 8	90101-12014	1 - 52		9 - 11
6X4-42102-21	6 - 1	6AH-42527-00	18 - 15		18 - 7		10 - 5		15 - 59		17 - 11
6X4-42102-31	8 - 1	6C5-42527-00	7 - 2	6X4-44100-00	1 - 21		10 - 8	90109-05M89	17 - 14		18 - 13
6X4-42102-41	10 - 1	67C-42527-03	9 - 2		15 - 21		11 - 7	90109-06M88	7 - 3	90386-08032	1 - 16
6X4-42102-51	11 - 1	63D-42528-00	5 - 17	6X4-44102-00	1 - 23		11 - 10		9 - 3		15 - 16
6X4-42102-61	13 - 1		14 - 9		15 - 23		13 - 5		17 - 4	90386-12003	1 - 57
6X4-42103-02	15 - 1	65W-42528-00	7 - 10	6X4-44132-00	1 - 25		13 - 8	90116-10031	4 - 5		15 - 64
6X4-42111-01-4D	1 - 2		9 - 10		15 - 25		15 - 40		10 - 3	90386-26MA3	1 - 46
	15 - 2		17 - 10	6X4-44139-00	1 - 9		15 - 46		11 - 4		10 - 15
6X4-42115-00	1 - 22		18 - 8		15 - 9	6X4-48538-00	1 - 35	90116-10175	3 - 4		15 - 53
	15 - 22	663-42528-00	12 - 3	6X4-44159-00-4D	1 - 42		15 - 36	90119-05018	18 - 3	90387-05M05	7 - 12
6X4-42119-00	1 - 5	63D-42541-00	14 - 4		15 - 49	6X4-48538-10	1 - 38	90119-08M74	5 - 2		9 - 12
	15 - 5	67G-42541-00	5 - 4	6X4-44159-10-4D	10 - 12		15 - 43	90142-05001	1 - 10		18 - 9
6X4-42121-00-4D	4 - 3	67G-42541-10	5 - 7	6X4-44173-00	1 - 43	6X4-81860-00	4 - 14		15 - 10	90387-05M11	7 - 14
	10 - 2	63D-42546-00	14 - 3		10 - 13		6 - 12	90161-06M00	14 - 17		9 - 14
	11 - 3	67G-42546-00	5 - 5		15 - 50	6X4-81942-00	2 - 13	90161-06M03	16 - 17		17 - 13
6X4-42121-10-4D	3 - 3	63D-42561-00	14 - 12	6X4-44177-00	1 - 12		16 - 14	90175-06003	12 - 5		18 - 10
65W-42121-11-4D	15 - 58	65W-42561-00	17 - 7		15 - 12	62Y-82361-00	16 - 16	90185-08057	5 - 14	90387-06M26	14 - 20
63D-42121-22-4D	1 - 51	67C-42561-00	7 - 7	6X4-44188-00	1 - 15	63D-82361-00	14 - 16		12 - 8		16 - 20
63D-42126-00	1 - 17		9 - 7		15 - 15	6X4-82510-00	2 - 1	90185-10051	3 - 5	90387-12M02	1 - 55
	15 - 17	67G-42561-00	5 - 15	6G8-44191-00	1 - 45		16 - 1		4 - 4		15 - 62
6X4-42128-00	1 - 13	68T-42561-00	18 - 6		15 - 52	6X4-82540-00	1 - 28		6 - 3	90447-22006	16 - 21
	15 - 13	63D-42562-00	14 - 10	6X4-47731-00	1 - 24		15 - 28		8 - 3	90447-22007	3 - 14
6X4-42131-01	1 - 47	65W-42562-00	17 - 6		15 - 24	682-82556-00	2 - 5		10 - 19		4 - 15
	15 - 54	67C-42562-00	7 - 6	6A5-48129-10	1 - 29		16 - 5		11 - 5	90464-08M07	2 - 3

NUMERICAL INDEX  
INDEX NUMERIQUE

PART NO. N° PIECES	REF. NO.	PART NO. N° PIECES	REF. NO.	PART NO. N° PIECES	REF. NO.	PART NO. N° PIECES	REF. NO.	PART NO. N° PIECES	REF. NO.	PART NO. N° PIECES	REF. NO.
90464-08M07	16 - 3	92990-08600	14 - 7	97095-08040	1 - 31						
90464-09M42	3 - 12	92990-12200	1 - 53		10 - 16						
	4 - 12		15 - 60		15 - 31						
	6 - 10	92990-12600	1 - 58	97095-08050	14 - 6						
	8 - 10		15 - 65	97780-60920	1 - 44						
	10 - 10	92995-05600	7 - 16		10 - 14						
	11 - 12		9 - 16		15 - 51						
	13 - 10		18 - 12	97880-06016	2 - 8						
	15 - 38	92995-06100	14 - 15		16 - 8						
90465-13M24	3 - 21	92995-06600	1 - 34	97885-06016	1 - 48						
	4 - 22		1 - 49		15 - 55						
	16 - 22		3 - 20								
90465-13M30	3 - 22		4 - 21								
	4 - 23		14 - 19								
90465-13M36	6 - 13		14 - 24								
	8 - 12		15 - 34								
	10 - 18		15 - 56								
	11 - 14		16 - 19								
	14 - 21	92995-08600	1 - 32								
	16 - 15		5 - 13								
90468-10005	3 - 8		10 - 17								
	3 - 11		15 - 32								
	4 - 8	93700-06M03	1 - 3								
	4 - 11		15 - 3								
	6 - 6		17 - 2								
	6 - 9	95380-05600	7 - 17								
	8 - 6		9 - 17								
	8 - 9	95380-06600	1 - 19								
	10 - 6		15 - 19								
	10 - 9	97080-06035	12 - 4								
	11 - 8	97095-05020	7 - 15								
	11 - 11		9 - 15								
	13 - 6		18 - 11								
	13 - 9	97095-06014	1 - 37								
	15 - 41		1 - 40								
	15 - 47		2 - 12								
90501-23215	1 - 14		15 - 39								
	15 - 14		15 - 45								
91490-20010	1 - 11		16 - 13								
	1 - 20	97095-06016	3 - 19								
	15 - 11		4 - 20								
	15 - 20		14 - 14								
92990-06100	7 - 5		14 - 23								
	9 - 5	97095-06030	1 - 33								
	17 - 5		15 - 33								
92990-06600	2 - 9	97095-06035	14 - 18								
	16 - 9		16 - 18								
92990-08600	12 - 7	97095-08025	5 - 12								