



# PARTS CATALOGUE

# RIGGING-METER

---



1V601-10MEA

( )

RIGGING-METER  
PARTS CATALOGUE

©2021 by Yamaha Motor Co., Ltd.  
1st edition, November 2021

All rights reserved.

Any reprinting or unauthorized use  
without the written permission of

Yamaha Motor Co., Ltd.

is expressly prohibited.

Printed in Japan.

# FOREWORD

This Parts Catalogue is related to the parts for the model(s) on the cover page. When you are ordering replacement parts, please refer to this Parts Catalogue and quote both part numbers and part names correctly.

1. Modifications or additions which have been made after the issue of the Parts Catalogue will be announced in the Parts News.  
It is advisable that you make the necessary corrections to the Parts Catalogue according to the Parts News.

2. Abbreviations

The following abbreviations are used in this Parts Catalogue.

“UR” Use specified parts number.

“UN” Use as many as needed.

“AP” Alternate Parts

“LM” Locally Made (Parts need to be ordered locally)

“F#” Frame No. (Applicable machine No.)

“O/S” Over Size

3. The number of components for assembly

- Parts, which are to be supplied in an assembly, are listed with a dot (.) in front of the part name as shown below.
- The numeral appearing to the right of each component part indicates the quantity of parts for each assembly unit.

PART NO.	DESCRIPTION	Q'TY	REMARKS
2F5-83310-60	FRONT FLASHER LIGHT ASSY	2	
115-83311-60	.BULB (6V-18W)	1	

4. Applicable colours of graphics are represented in the “REMARKS” as shown below.

PART NO.	DESCRIPTION	Q'TY	REMARKS
2N4-24110-00-X5	FUEL TANK COMP.	2	MXR
3J1-24240-10	.GRAPHIC, FUEL TANK	1	FOR MXR

5. Note that the illustrations for reference in finding parts numbers are not to be used for assembling. When assembling, please use the applicable service manual.

6. The asterisk (\*) before a reference number indicates modified items after the first edition.

# CONTENTS

METER 1.....	1
METER 2.....	2
METER 3.....	3
METER 4.....	4
METER 5.....	5
METER 6.....	6
METER 7.....	7
METER 8.....	8
WIRE HARNESS 1.....	9
WIRE HARNESS 2.....	10
ELECTRICAL.....	11
DIGITAL NETWORK GAUGE 1.....	12
DIGITAL NETWORK GAUGE 2.....	13
DIGITAL NETWORK GAUGE 3.....	14
DIGITAL NETWORK GAUGE 4.....	15
DIGITAL NETWORK GAUGE 5.....	16
DIGITAL NETWORK GAUGE 6.....	17
DIGITAL NETWORK GAUGE 7.....	18
DIGITAL NETWORK GAUGE 8.....	19
CL7 DISPLAY 1.....	20
CL7 DISPLAY 2.....	21
CL5 DISPLAY 1.....	22
CL5 DISPLAY 2.....	23
WIRE HARNESS 3.....	24
IMMOBILIZER KIT.....	25
DES.....	26
HELM UNIT.....	27

## INDEX

NUMERICAL INDEX.....	28
----------------------	----

## DIGITAL TACHOMETER

Ref. No.	Description	Part No.	Applicable model
1	Multifunction w/o "Check engine" and "Water in fuel" indicators	6Y5-8350T-E0	Above 40 (3-cyl) w/ oil injection Above F30 [Mechanical HC]

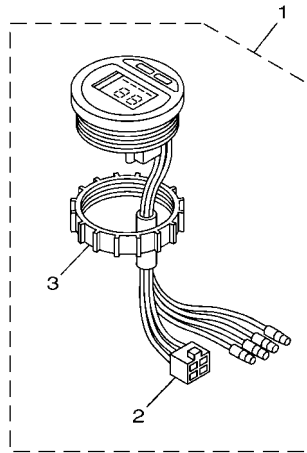

601M10M-R010

### FIG. 1 METER 1

REF. NO.	PART NO.	DESCRIPTION	601M			REMARKS
1	6Y5-8350T-E0	TACHOMETER ASSY	1			
2	9E450-04533	.CONNECTOR	1			F-4-W
3	6Y8-84383-00	.NUT, RING	1			

### ANALOG TACHOMETER

Ref. No.	Description	Part No.	Applicable model
1	Without indicators BLK panel	6Y7-83540-21	Above 9.9 (Pre-mixed) FT8 (T8),F9.9 -F25 (FT/T25)
2	With overheat & oil indicators BLK panel	6Y7-83540-81	Above 40 (3-cyl) w/ oil injection Above F30 [Mechanical RC]
	With overheat & oil indicators WHT panel	6Y7-83540-51 6Y7-83540-91	

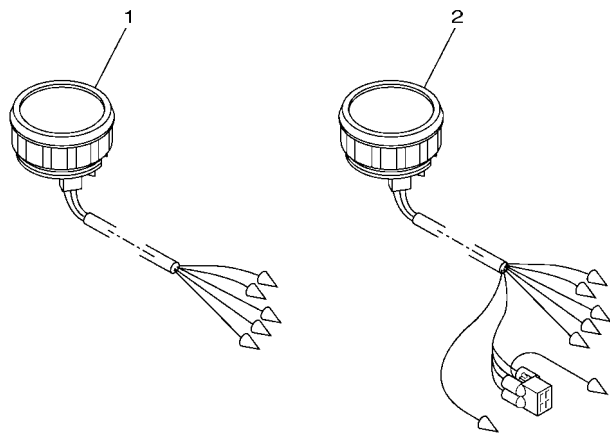

601M10M-V020

### FIG. 2 METER 2

REF. NO.	PART NO.	DESCRIPTION	601M				REMARKS
1	6Y7-83540-21	TACHOMETER ASSY	1				WITHOUT OIL LAMP
2	6Y7-83540-81	TACHOMETER ASSY	1				UR WITH OIL/TEMP LAMP
	6Y7-83540-51	TACHOMETER ASSY	1				UR WITH OIL/TEMP LAMP
	6Y7-83540-91	TACHOMETER ASSY	1				UR WITH OIL/TEMP LAMP
<hr/>							
<hr/>							
<hr/>							
<hr/>							
<hr/>							
<hr/>							
<hr/>							
<hr/>							
<hr/>							
<hr/>							
<hr/>							
<hr/>							
<hr/>							
<hr/>							
<hr/>							
<hr/>							
<hr/>							
<hr/>							
<hr/>							
<hr/>							
<hr/>							
<hr/>							
<hr/>							
<hr/>							
<hr/>							
<hr/>							
<hr/>							
<hr/>							

# DIGITAL SPEEDOMETER

Ref. No.	Description	Part No.	Applicable model
1	Digital multifunction	6Y5-83570-A0	Above 40 (3-cyl) Above F30 [Mechanical RC]

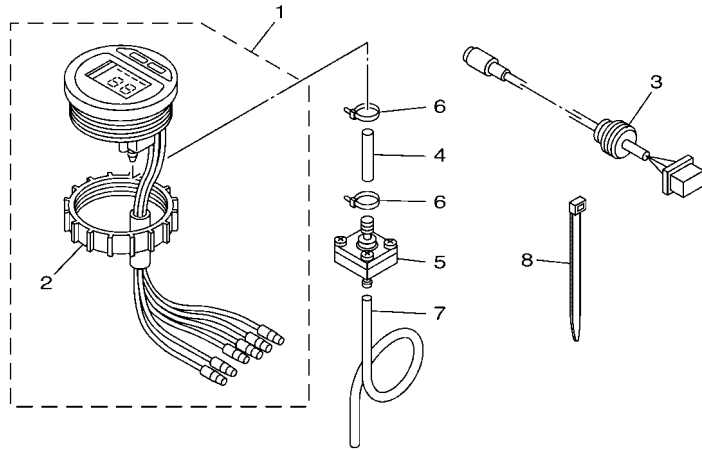

601M10M-R030

### FIG. 3 METER 3

REF. NO.	PART NO.	DESCRIPTION	601M	REMARKS
1	6Y5-83570-A0	SPEEDOMETER ASSY	1	
2	6Y8-84383-00	.NUT, RING	1	
3	6Y5-87122-S0	CORD ASSY 1	1	
4	6Y5-83557-31	TUBE	1	
5	6Y5-83728-00	CONNECTOR ASSY	1	
6	90465-11M10	CLAMP	2	
7	6Y5-83557-00	TUBE (6M)	1	
8	90465-11M10	CLAMP	2	

# ANALOG SPEEDOMETER

Description	Part No.	Applicable model
Analog, BLK panel 0 - 75 mph (20 - 120 km/h)	6Y7-83510-00	Above 40 (3-cyl) Above F30 [Mechanical RC]
Analog, WHT panel 0 - 75 mph (20 - 120 km/h)	6Y7-83510-10	
Analog, BLK panel 0 - 50 mph (20 - 80 km/h)	6Y7-83510-20	
Analog, WHT panel 0 - 50 mph (20 - 80 km/h)	6Y7-83510-30	
Analog, BLK panel 0 - 120 km/h (15 - 65 knot)	6Y7-83510-40	
Analog, WHT panel 0 - 120 km/h (15 - 65 knot)	6Y7-83510-50	
Analog, BLK panel 0 - 80 km/h (10 - 43 knot)	6Y7-83510-60	
Analog, WHT panel 0 - 80 km/h (10 - 43 knot)	6Y7-83510-70	

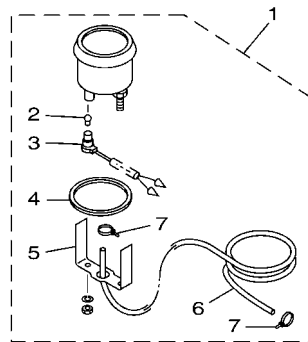

601M10M-K040

FIG. 4 METER 4

REF. NO.	PART NO.	DESCRIPTION	601M	REMARKS
1	6Y7-83510-00	SPEEDOMETER ASSY (75MPH)	1	UR
	6Y7-83510-10	SPEEDOMETER ASSY (75MPH)	1	UR
	6Y7-83510-20	SPEEDOMETER ASSY (50MPH)	1	UR
	6Y7-83510-30	SPEEDOMETER ASSY (50MPH)	1	UR
	6Y7-83510-40	SPEEDOMETER ASSY (120KM/H)	1	UR
	6Y7-83510-50	SPEEDOMETER ASSY (120KM/H)	1	UR
	6Y7-83510-60	SPEEDOMETER ASSY (80KM/H)	1	UR
	6Y7-83510-70	SPEEDOMETER ASSY (80KM/H)	1	UR
2	6Y5-83517-00	.BULB (T10, 12V-1.7W)	1	
3	6Y5-83536-40	.SOCKET, METER	1	
4	6Y5-83523-00	.DAMPER	1	
5	6Y5-83514-00	.PLATE, FITTING	1	
6	688-83557-00	.TUBE	1	
7	90465-11M10	.CLAMP	2	



## FUEL MANAGEMENT GAUGE

Ref. No.	Description	Part No.	Applicable model
1	Fuel mgt gauge kit For single-engine	6Y5-W0088-55	Above 115 HP engines

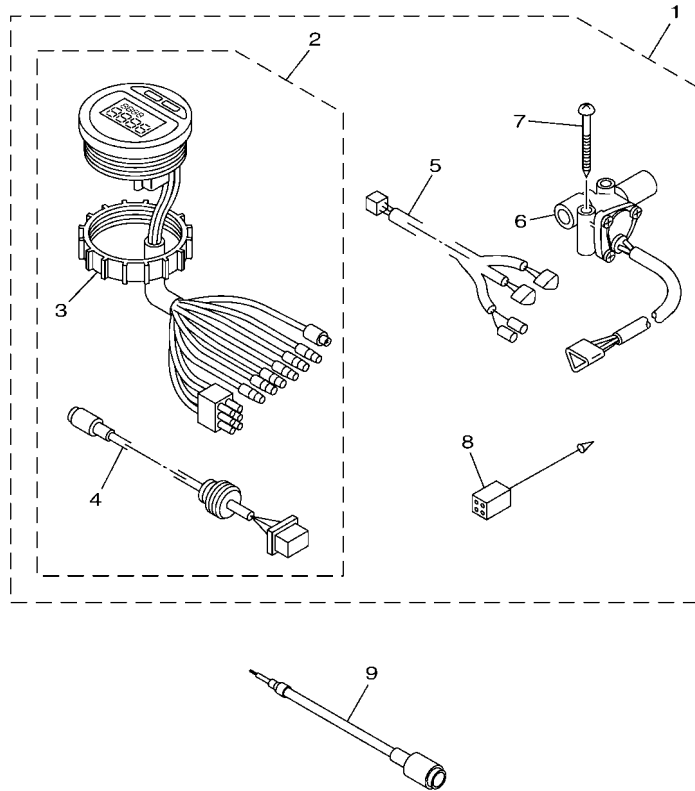

601M10M-U050

### FIG. 5 METER 5

REF. NO.	PART NO.	DESCRIPTION	601M	REMARKS
1	6Y5-W0088-55	DIGITAL FUEL METER KIT(SINGLE)	1	
2	6Y5-8350F-B0	.FUEL METER MOVEMENT ASSY	1	
3	6Y8-84383-00	..NUT, RING	1	
4	6Y5-87122-S0	..CORD ASSY 1	1	
5	6Y5-83553-F1	.WIRE, LEAD (L=8.0M)	1	
6	6Y5-85752-02	.SENDER UNIT ASSY, FUEL METER	1	
7	90158-06003	.SCREW, WOOD	2	
8	6Y5-82117-00	.WIRE, LEAD (BLACK) (L300)	1	
9	6Y5-85721-F0	WIRE, LEAD	1	AP

### ANALOG TRIM METER

Description	Part No.	Applicable model
4-pin coupler BLK panel	6Y7-83670-00	Pre-mixed w/ PTT
Bullet connector BLK panel	6Y7-83670-40	Above 40 (3-cyl) w/ oil injection & PTT, Above F30 w/ PTT [Mechanical RC], T25 (NOA) Use as a set with tachometer, 6Y7-83540-81
4-pin coupler WHT panel	6Y7-83670-20	Pre-mixed w/ PTT
Bullet connector WHT panel	6Y7-83670-50	Above 40 (3-cyl) w/ oil injection & PTT, Above F30 w/ PTT [Mechanical RC], T25 (NOA) Using as a set with tachometer, 6Y7-83540-91

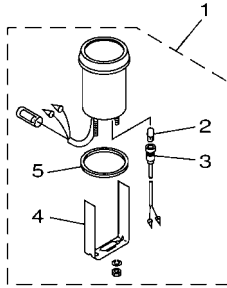

### COOLANT PRESSURE METER

Description	Part No.	Applicable model
kPa, Black panel	6Y7-83660-00	Above 40 [3-cyl]
psi, Black panel	6Y7-83660-10	Above F25 (FT/T25) [Mechanical RC]
psi, White panel	6Y7-83660-30	

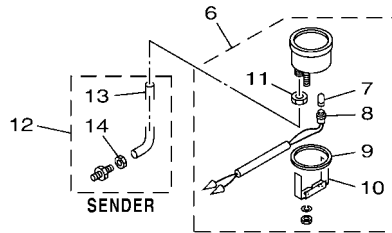

601M10M-U060

FIG. 6 METER 6

REF. NO.	PART NO.	DESCRIPTION	601M	REMARKS
1	6Y7-83670-00	TRIM METER ASSY.	1	UR
	6Y7-83670-40	TRIM METER ASSY.	1	UR
	6Y7-83670-20	TRIM METER ASSY.	1	UR
	6Y7-83670-50	TRIM METER ASSY.	1	UR
2	6Y5-83518-00	.BULB (12V-1.7W T6.5)	1	
3	6Y5-83536-00	.SOCKET, METER	1	
4	6Y5-83544-00	.PLATE, FITTING	1	
5	688-83664-00	.DAMPER	1	
6	6Y7-83660-00	WATER PRESSURE METER ASSY	1	UR
	6Y7-83660-10	WATER PRESSURE METER ASSY	1	UR
	6Y7-83660-30	WATER PRESSURE METER ASSY	1	UR
7	6Y5-83518-00	.BULB (12V-1.7W T6.5)	1	
8	6Y5-83536-00	.SOCKET, METER	1	
9	688-83664-00	.DAMPER	1	
10	688-83665-00	.PLATE, FITTING	1	
11	663-83668-00	.NUT, NIPPLE	1	
12	688-83667-01	SENDER	1	
13	688-83666-00	.TUBE	1	
14	663-83668-10	.NUT, NIPPLE	1	

### COOLANT TEMP. METER

Description	Part No.	Applicable model
Black panel	6Y7-83590-00	Above 40 [3-cylinder]
White panel	6Y7-83590-10	Above F25 (FT/T25) [Mechanical RC]

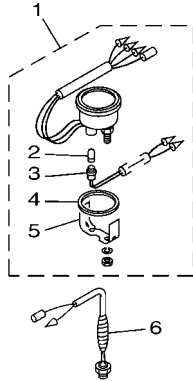

### HOUR METER

Ref. No.	Description	Part No.	Applicable model
7	Mechanical	6Y5-83504-01	All electrical start models
	Digital, Black panel	6Y7-83504-00	
14	Digital, White panel	6Y7-83504-10	

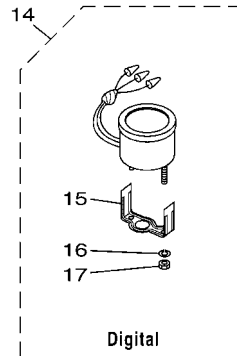
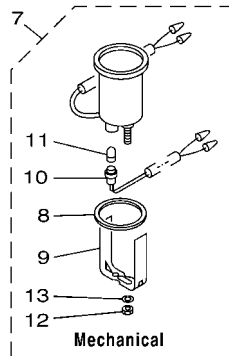

601M10M-K070

FIG. 7 METER 7

REF. NO.	PART NO.	DESCRIPTION	601M	REMARKS
1	6Y7-83590-00	WATER TEMPERATURE ASSY	1	UR
	6Y7-83590-10	WATER TEMPERATURE ASSY	1	UR
2	6Y5-83518-00	.BULB (12V-1.7W T6.5)	1	
3	6Y5-83536-00	.SOCKET, METER	1	
4	688-83664-00	.DAMPER	1	
5	6Y5-83544-00	.PLATE, FITTING	1	
6	688-83591-00	THERMO UNIT	1	
7	6Y5-83504-01	HOUR METER ASSY	1	
8	688-83664-00	.DAMPER	1	
9	6Y5-83577-00	.PLATE, FITTING	1	
10	6Y5-83536-00	.SOCKET, METER	1	
11	6Y5-83518-00	.BULB (12V-1.7W T6.5)	1	
12	95303-04600	.NUT	2	
13	92990-04100	.WASHER, SPRING	2	
14	6Y7-83504-00	HOUR METER ASSY	1	UR
	6Y7-83504-10	HOUR METER ASSY	1	UR
15	6Y5-8355X-H0	.BRACKET, METER 1	1	
16	92990-04100	.WASHER, SPRING	2	
17	95380-04600	.NUT	2	

### VOLTAGE METER

Description	Part No.	Applicable model
DC 12 volt power supply Black panel	6Y7-83503-00	All electrical start models
DC 12 volt power supply White panel	6Y7-83503-10	

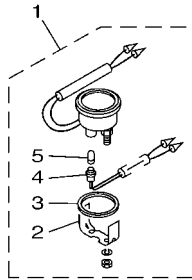

### FUEL METER

Description	Part No.	Applicable model
For Yamaha sensor (5 – 105Ω) Black panel	6Y7-85750-00	All electrical start models
For ABYC sensor (30 – 240Ω) Black panel	6Y7-85750-10	
For Yamaha sensor (5 – 105Ω) White panel	6Y7-85750-20	
For ABYC sensor (30 – 240Ω) White panel	6Y7-85750-30	

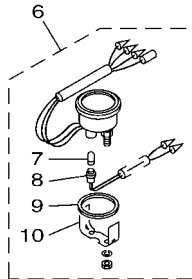

601M10M-P080

### FIG. 8 METER 8

REF. NO.	PART NO.	DESCRIPTION	601M	REMARKS
1	6Y7-83503-00	VOLTMETER ASSY	1	UR
	6Y7-83503-10	VOLTMETER ASSY	1	UR
2	6Y5-83544-00	.PLATE, FITTING	1	
3	688-83664-00	.DAMPER	1	
4	6Y5-83536-00	.SOCKET, METER	1	
5	6Y5-83518-00	.BULB (12V-1.7W T6.5)	1	
6	6Y7-85750-00	FUEL METER ASSY	1	UR
	6Y7-85750-10	FUEL METER ASSY	1	UR
	6Y7-85750-20	FUEL METER ASSY	1	UR
	6Y7-85750-30	FUEL METER ASSY	1	UR
7	6Y5-83518-00	.BULB (12V-1.7W T6.5)	1	
8	6Y5-83536-00	.SOCKET, METER	1	
9	688-83664-00	.DAMPER	1	
10	6Y5-83544-00	.PLATE, FITTING	1	

**ACCESSORY LEAD**

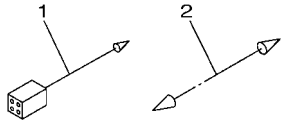

**METER HARNESS (For analog meter)**

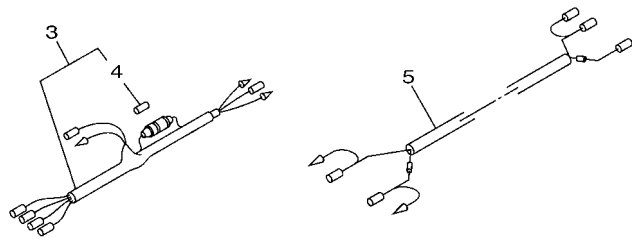

For pre-mixed model

**METER HARNESS (For digital meter)**

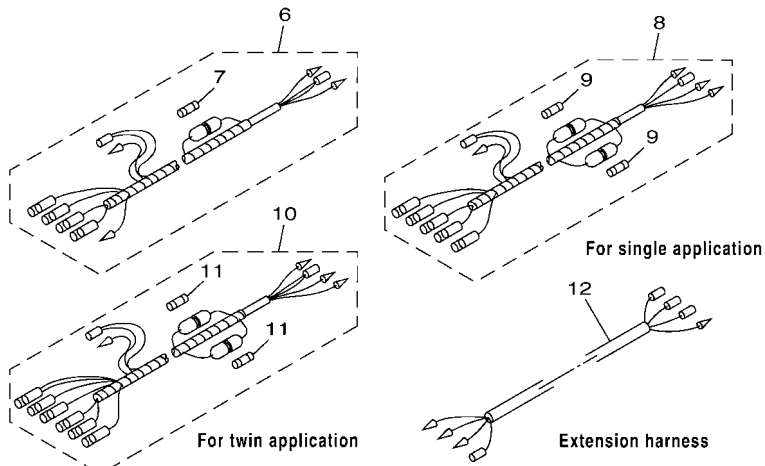

601M10M-Q090

**FIG. 9 WIRE HARNESS 1**

REF. NO.	PART NO.	DESCRIPTION	601M				REMARKS
1	6Y5-82149-00	WIRE, LEAD (BLUE) (L300)	1				UR
	6Y5-82117-00	WIRE, LEAD (BLACK) (L300)	1				UR
2	703-82531-00	WIRE, LEAD (L70)	1				L/H MODEL
3	6Y5-83553-01	WIRE, LEAD (L=2.5M)	1				
4	6G1-82151-01	.FUSE (10A)	1				
5	6Y5-83553-10	WIRE, LEAD (L=5.0M)	1				
6	6Y5-83553-21	WIRE, LEAD (L=2.5M)	1				L/H MODEL
7	6G1-82151-01	.FUSE (10A)	1				
8	6Y5-83553-M1	WIRE, LEAD (L=2.5M)	1				
9	6G1-82151-01	.FUSE (10A)	2				
10	6Y5-83553-N1	WIRE, LEAD (L=2.5M)	1				
11	6G1-82151-01	.FUSE (10A)	2				
12	6Y5-8356N-00	WIRE, LEAD (L=1.5M)	1				

**LAMP SWITCH**

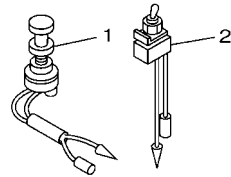

**TRIM METER LEAD**

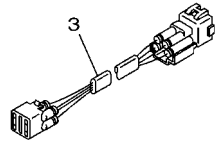

Premixed models W/PTT  
(Flat type harness)

**TRIM AND OIL LEAD**

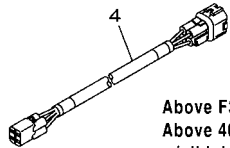

Above F30(Mechanical RC)  
Above 40(3-cyl)  
w/oil injection  
(Unified 4-pin coupler)

**FUEL MANAGEMENT GAUGE HARNESS**

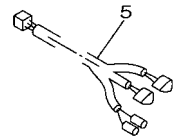

**LIGHTING COIL EXTENSION HARNESS**

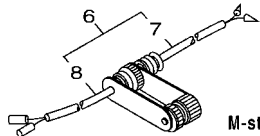

M-start model  
with lighting coil

**CONVERSION HARNESS 1**

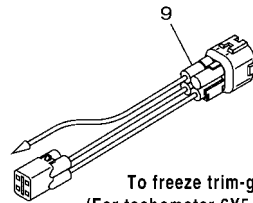

To freeze trim-gauge  
(For tachometer 6Y5-8350T-E0)  
for hydro-tilt model

**RECTIFIER KIT**

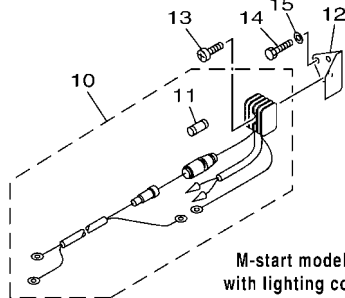

M-start model  
with lighting coil

601M10M-R100

**FIG. 10 WIRE HARNESS 2**

REF. NO.	PART NO.	DESCRIPTION	601M				REMARKS
1	688-82520-00	LIGHT SWITCH ASSY	1				
2	688-82526-00	SWITCH, LAMP	1				
3	6R3-82553-30	EXTENSION, WIRE LEAD (L=3.0M)	1				UR (4P)
	6R3-82553-50	EXTENSION, WIRE LEAD (L=5.0M)	1				UR (4P)
	6R3-82553-70	EXTENSION, WIRE LEAD (L=7.0M)	1				UR (4P)
	6R3-82553-80	EXTENSION, WIRE LEAD (L=8.0M)	1				UR (4P)
	6R3-82553-90	EXTENSION, WIRE LEAD (L=9.0M)	1				UR (4P)
4	6Y5-83653-00	WIRE, LEAD (L=5.0M)	1				UR 4P,5M
	6Y5-83653-10	WIRE, LEAD (L=6.0M)	1				UR 4P,6M
	6Y5-83653-20	WIRE, LEAD (L=7.0M)	1				UR 4P,7M
	6Y5-83653-30	WIRE, LEAD (L=8.0M)	1				UR 4P,8M
	6Y5-83653-40	WIRE, LEAD (L=9.0M)	1				UR 4P,9M
	6Y5-83653-50	WIRE, LEAD (L=10.5M)	1				UR 4P,10.5M
5	6Y5-83553-F1	WIRE, LEAD (L=8.0M)	1				
6	682-84380-00	CONCENT 2P	1				
7	682-84381-00	.2P CONCENT	1				
8	682-84382-00	.2P CONCENT	1				
9	6Y5-8350U-10	WIRE, LEAD	1				
10	676-81970-02	RECTIFIER ASSY	1				
11	663-82151-01	.FUSE (12V-20A)	1				
12	*	PLATE, RECTIFIER FITTING	1				LM
13	97880-05025	SCREW, PAN HEAD	1				
14	97013-06010	BOLT	2				
15	92903-06600	WASHER, PLATE	2				

**CHARGE WARNING UNIT**

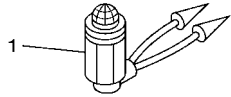

**IMMOBILIZER POWER DISTRIBUTION WIRE**

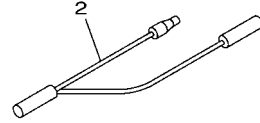

For fuel injection four stroke multi-application w/ immobilizer

**BATTERY WIRING**

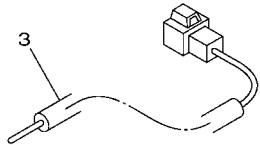

Part No.	Length	Conductor cross-sectional area		Remarks
		AWG	mm <sup>2</sup>	
68F-81949-03	2.7 m 9 ft	10	5	4-stroke 150 and larger *Except below offshore engines
69J-81949-03	3.8 m 13 ft	10	5	
6KW-81949-00	3.8 m 13 ft	5	15	4-stroke offshore 225 to 300 (V6-4.2L)

601M10M-V110

**FIG. 11 ELECTRICAL**

REF. NO.	PART NO.	DESCRIPTION	601M				REMARKS
1	663-84301-01	PILOT LIGHT ASSY 1	1				12V
2	6H5-81315-00	LEAD WIRE ASSY	1				
3	68F-81949-03	WIRE, LEAD	1				UR
	69J-81949-03	WIRE, LEAD (ISOLATOR, 3.8M )	1				UR
	6KW-81949-00	WIRE, LEAD (ISOLATOR CABLE)	1				UR
-----							
-----							
-----							
-----							
-----							
-----							
-----							
-----							
-----							

**MULTIFUNCTION METER**

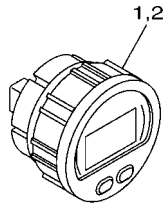

6Y8-83500-21  
Requires optional speed sensor,  
or NMEA compatible GPS

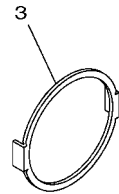

For 6Y8 meters

**MULTI-SENSOR**

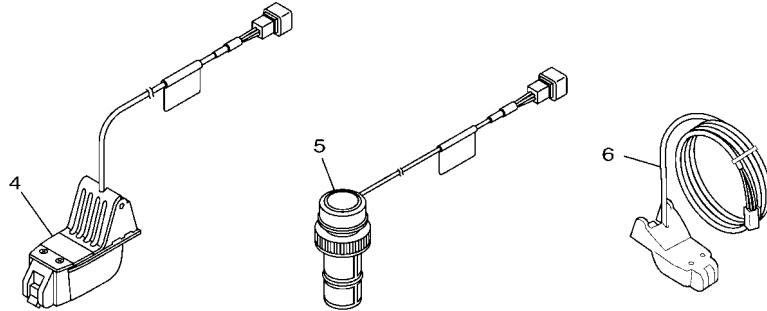

Discontinued, available for stock only.  
After sold out, 6Y9-83688-00 will be supplied.

**NMEA2000 GATEWAY**

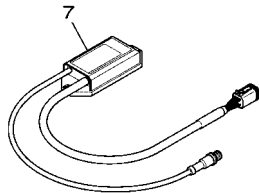

Compatible with 6Y8 and 6Y9 protocols



601M10M-V120

**ANALOG GAUGE INTERFACE**

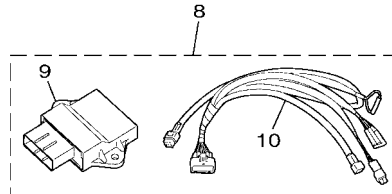

Compatible with 6Y8 and 6Y9 protocols,  
Required for each engine.

**FIG. 12 DIGITAL NETWORK GAUGE 1**

REF. NO.	PART NO.	DESCRIPTION	601M				REMARKS
1	6Y8-8350T-21	TACHOMETER, RD	1				
2	6Y8-83500-21	S & FM METER, RD	1				SPEED & FUEL
3	6Y8-83514-00	PLATE, FITTING	1				UN
4	6Y8-83688-01	TRANSOM MOUNT TRIDUCER	1				
5	6Y8-83688-11	PLASTIC THRU-HULL TRIDUCER	1				PLASTIC BODY
6	6Y9-83688-00	SENSOR ASSY	1				
7	99999-04422	INTERFACE UNIT SET	1				GATEWAY
8	6YH-W8A2D-00	INTERFACE UNIT SET	1				ANALOGUE GAUGE
9	6YH-8A2D0-00	.INTERFACE UNIT	1				
10	6YH-82521-00	.WIRE, LEAD	1				



**NETWORK HUB**

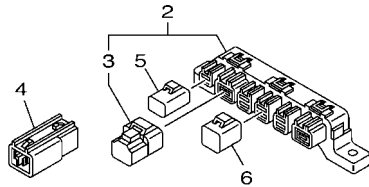

Ref. No.	Description	Part No.	Remarks
2	Multi-hub	6Y8-81920-01	w/ ending resistor cap (P/N: 6Y8-85371-01)
4	Single hub (Inline hub)	6Y8-81920-11	Included ending resistor
5	2P sealing cap, RED	6Y8-82582-01	
6	4P sealing cap, WHT	6Y8-82582-11	Same as bus wire cap of engine wire harness

**FUEL TANK / GPS WIRE**

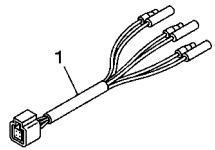

Twin fuel tanks acceptable

**WIRE HARNESSA**

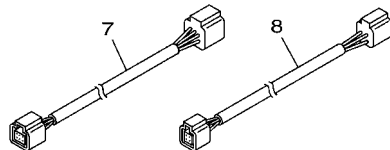

**WIRE HARNESSA**

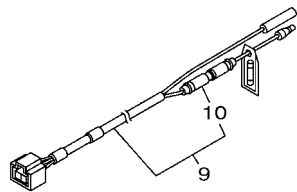

With 10 amp fuse

601M10M-T130

**FIG. 13 DIGITAL NETWORK GAUGE 2**

REF. NO.	PART NO.	DESCRIPTION	601M	REMARKS
1	6Y8-8356N-01	LEAD, FUEL TANK & GPS SENDER	1	
2	6Y8-81920-01	MULTI HUB ASSY	1	UN
3	6Y8-85371-01	.END OF LINE RESISTOR	1	
4	6Y8-81920-11	IN-LINE HUB ASSY	1	
5	6Y8-82582-01	CAP 1 (2PIN)	1	UN
6	6Y8-82582-11	CAP 1 (4PIN)	1	UN
7	6Y8-82553-01	1FT MAIN BUS	1	UR
	6Y8-82553-11	15FT MAIN BUS	1	UR
	6Y8-82553-21	20FT MAIN BUS	1	UR
	6Y8-82553-31	25FT MAIN BUS	1	UR
	6Y8-82553-41	30FT MAIN BUS	1	UR
	6Y8-82553-50	10FT MAIN BUS	1	UR
8	6Y8-82521-01	1FT PIGTAIL BUS	1	UR
	6Y8-82521-11	2FT PIGTAIL BUS	1	UR
	6Y8-82521-21	3FT PIGTAIL BUS	1	UR
	6Y8-82521-31	6FT PIGTAIL BUS	1	UR
	6Y8-82521-41	9FT PIGTAIL BUS	1	UR
	6Y8-82521-51	12FT PIGTAIL BUS	1	UR
9	6Y8-83553-02	8FT POWER WIRE	1	
10	6G1-82151-01	.FUSE (10A)	1	

### COOLANT PRESSURE SENSOR

Kit Part No.	Remarks
60V-8A4L0-1A	F30B, F40F, F40G, F40H, F50H, FT50J, F60F, FT60G, F70A, F75D, F80D, F90C, F90D, F100F, F115B, FL115B, F115C, F125A, F130A, F150D, FL150D, F150F, FL150F

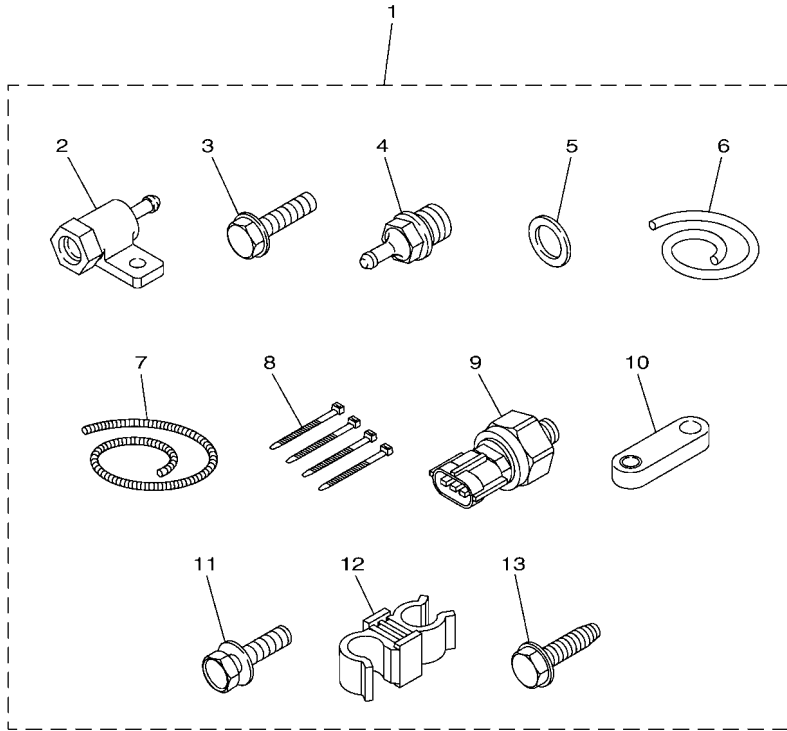

601M10M-U140

**FIG. 14 DIGITAL NETWORK GAUGE 3**

REF. NO.	PART NO.	DESCRIPTION	601M				REMARKS
1	60V-8A4L0-1A	SENSOR, MODULE	1				
2	60V-8366D-00	.ADAPTOR, INPUT	1				
3	95D95-06025	.BOLT, FLANGE DEEP RECESS	1				
4	60V-83667-00	.SENDER, WATER PRESSURE	1				
5	90430-14115	.GASKET	1				
6	90445-07018	.HOSE (L1400)	1				
7	90447-07015	.HOSE, COVER (L: 1300MM)	1				
8	90465-11M10	.CLAMP	4				
9	6AW-8366B-02	.SENSOR, WATER PRESSURE	1				
10	60V-8257V-00	.PLATE, CONNECTOR	1				
11	97E95-06516	.BOLT, HEXAGON W/W DEEP RECESS	1				
12	90464-09021	.CLAMP	1				
13	90109-06M81	.BOLT	1				

### COOLANT PRESSURE SENSOR

Kit Part No.	Remarks
63P-8A4L0-06	F150C, F150G, FL150G, F165A, F175A, F175B, F175C, FL175C, F185A, F200B, FL200B, F200C, FL200C, F200D, F200F, FL200F, F200G, FL200G, F200H, F225B, FL225B, F225D, F225F, FL225F, F225G, F225H, FL225H, F225J, FL225J, F250C, F250D, FL250D, F250F, F250J, F250L, FL250L, F250N, F250P, FL250P, F275A, F300B, FL300B, F300C, FL300C, F300D, FL300D, F300F, FL300F, F300G, FL300G
63P-8A4L0-11	FL200B, FL200C, FL150D, FL150F, FL200F, FL250H, FL300B, FL250D, FL225F, F300D, FL300D

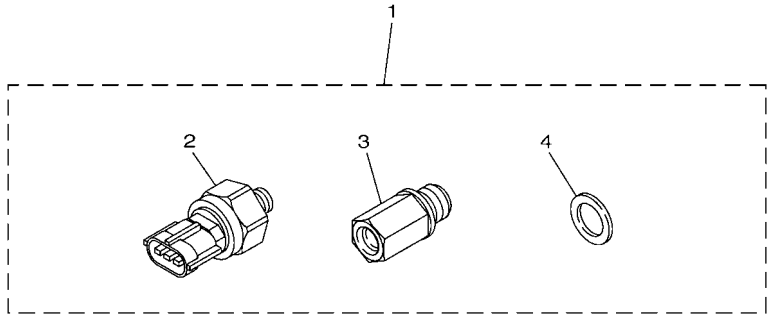

601M10M-V150

FIG. 15 DIGITAL NETWORK GAUGE 4

REF. NO.	PART NO.	DESCRIPTION	601M				REMARKS
1	63P-8A4L0-06	SENSOR, MODULE	1				UR
	63P-8A4L0-11	SENSOR, MODULE	1				UR
2	6AW-8366B-02	.SENSOR, WATER PRESSURE	1				
3	63P-8366C-00	.ADAPTOR, INPUT	1				
4	90430-14115	.GASKET	1				

**SPEED SENSOR**

Part No.	Remarks
60V-8A4L1-1B	Fuel injected F30-F300 (V6)

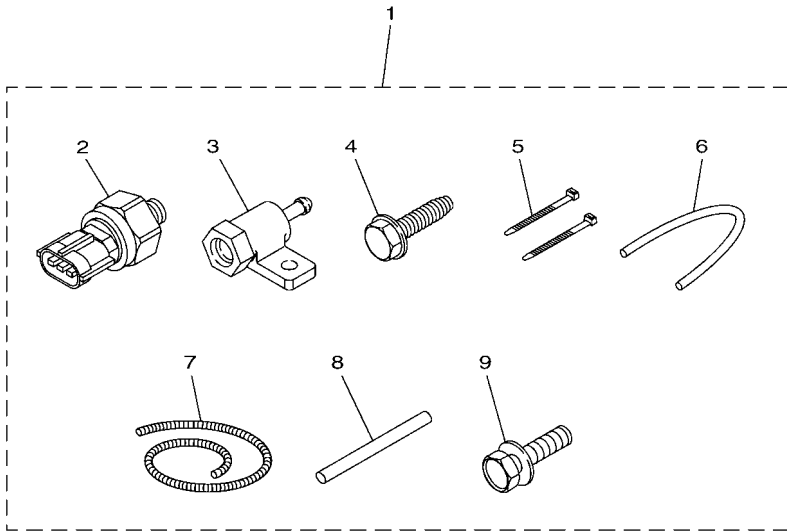

601M10M-V160

**FIG. 16 DIGITAL NETWORK GAUGE 5**

REF. NO.	PART NO.	DESCRIPTION	601M					REMARKS
1	60V-8A4L1-1B	SENSOR, MODULE 1	1					
2	6AW-8366B-02	.SENSOR, WATER PRESSURE	1					
3	60V-8366D-00	.ADAPTOR, INPUT	1					
4	90109-06M81	.BOLT	1					
5	90465-11M10	.CLAMP	2					
6	90445-07017	.HOSE (L: 550MM)	1					
7	90447-07013	.HOSE, COVER (L: 700MM)	1					
8	60V-42629-01	.SEAL	1					
9	97E95-06516	.BOLT, HEXAGON W/W DEEP RECESS	1					

### COOLANT PRESSURE SENSOR

Part No.	Remarks
63P-8A4L2-06	F150C, F150G, FL150G, F165A, F175A, F175B, F175C, FL175C, F185A, F200C, FL200C, F200F, FL200F, F200G, FL200G, F200B, FL200B, F200D, F200H, F225B, FL225B, F225F, FL225F, F225D, F225G, F225H, FL225H, F225J, FL225J, F250D, FL250D, F250C, F250F, F250J, F250L, FL250L, F250N, FL250N, F250P, FL250P, F275A, F300B, FL300B, F300D, FL300D, F300C, FL300C, F300F, FL300F, F300G, FL300G

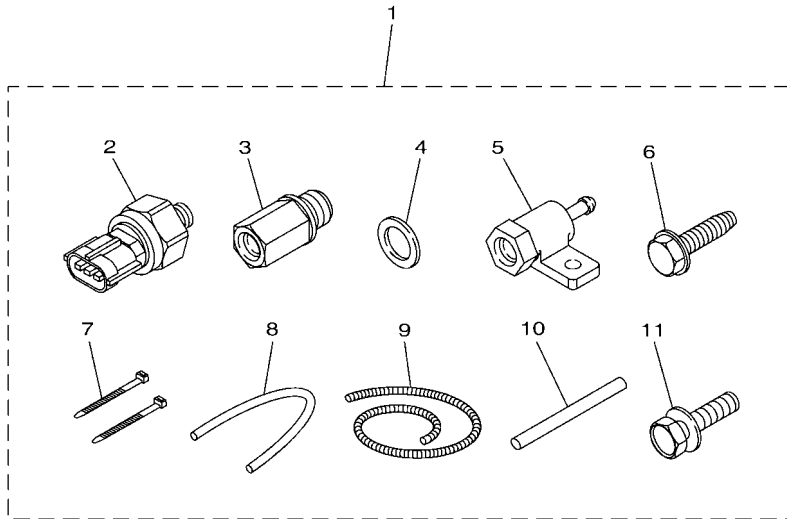

601M10M-V170

FIG. 17 DIGITAL NETWORK GAUGE 6

REF. NO.	PART NO.	DESCRIPTION	601M				REMARKS
1	63P-8A4L2-06	SENSOR, MODULE 2	1				
2	6AW-8366B-02	.SENSOR, WATER PRESSURE	2				
3	63P-8366C-00	.ADAPTOR, INPUT	1				
4	90430-14115	.GASKET	1				
5	60V-8366D-00	.ADAPTOR, INPUT	1				
6	90109-06M81	.BOLT	1				
7	90465-11M10	.CLAMP	2				
8	90445-07017	.HOSE (L: 550MM)	1				
9	90447-07013	.HOSE, COVER (L: 700MM)	1				
10	60V-42629-01	.SEAL	1				
11	97E95-06516	.BOLT, HEXAGON W/W DEEP RECESS	1				

**SPEED/COOLANT PRESSURE SENSOR**

Part No.	Remarks
60V-8A4L2-07	F115B, FL115B, F130A

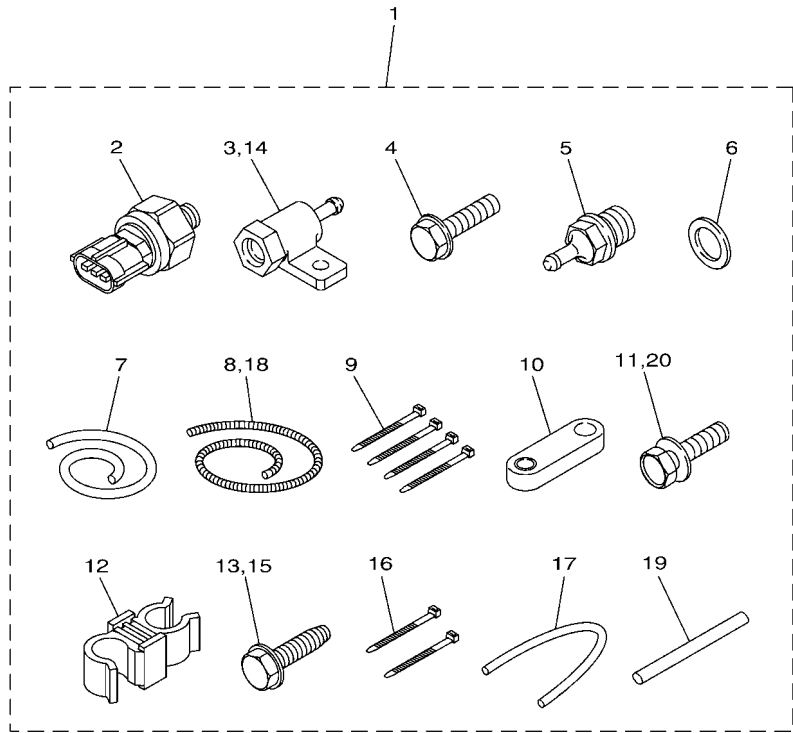

601M10M-V180

**FIG. 18 DIGITAL NETWORK GAUGE 7**

REF. NO.	PART NO.	DESCRIPTION	601M	REMARKS
1	60V-8A4L2-07	SENSOR, MODULE 2	1	
2	6AW-8366B-02	.SENSOR, WATER PRESSURE	2	
3	60V-8366D-00	.ADAPTOR, INPUT	1	
4	95D95-06025	.BOLT, FLANGE DEEP RECESS	1	
5	60V-83667-00	.SENDER, WATER PRESSURE	1	
6	90430-14115	.GASKET	1	
7	90445-07018	.HOSE (L1400)	1	
8	90447-07015	.HOSE, COVER (L: 1300MM)	1	
9	90465-11M10	.CLAMP	4	
10	60V-8257V-00	.PLATE, CONNECTOR	1	
11	97E95-06516	.BOLT, HEXAGON W/W DEEP RECESS	1	
12	90464-09021	.CLAMP	1	
13	90109-06M81	.BOLT	1	
14	60V-8366D-00	.ADAPTOR, INPUT	1	
15	90109-06M81	.BOLT	1	
16	90465-11M10	.CLAMP	2	
17	90445-07017	.HOSE (L: 550MM)	1	
18	90447-07013	.HOSE, COVER (L: 700MM)	1	
19	60V-42629-01	.SEAL	1	
20	97E95-06516	.BOLT, HEXAGON W/W DEEP RECESS	1	

### COOLANT PRESSURE SENSOR CONNECTOR

Part No.	Remarks
6P2-83728-01	As a set with COOLANT PRESSURE SENSOR KIT for F200-F250 (V6-3.3L)

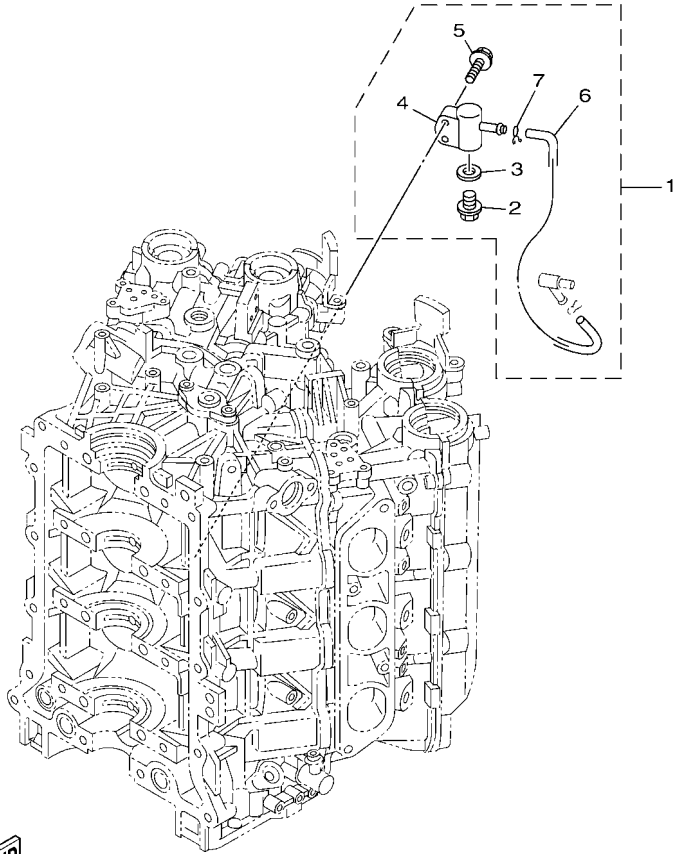

601M10M-T180

**FIG. 19 DIGITAL NETWORK GAUGE 8**

REF. NO.	PART NO.	DESCRIPTION	601M	REMARKS
1	6P2-83728-01	CONNECTOR ASSY	1	NOT FOR SALE
2	90340-14M06	.PLUG, STRAIGHT SCREW	1	
3	90430-14115	.GASKET	1	
4	6P2-83652-00	.CONNECTOR	1	
5	97E95-06530	.BOLT, HEXAGON W/W DEEP RECESS	2	
6	6H4-24311-00	.PIPE, FUEL 1	1	
7	90467-08M18	.CLIP	1	

FIG. 20 CL7 DISPLAY 1

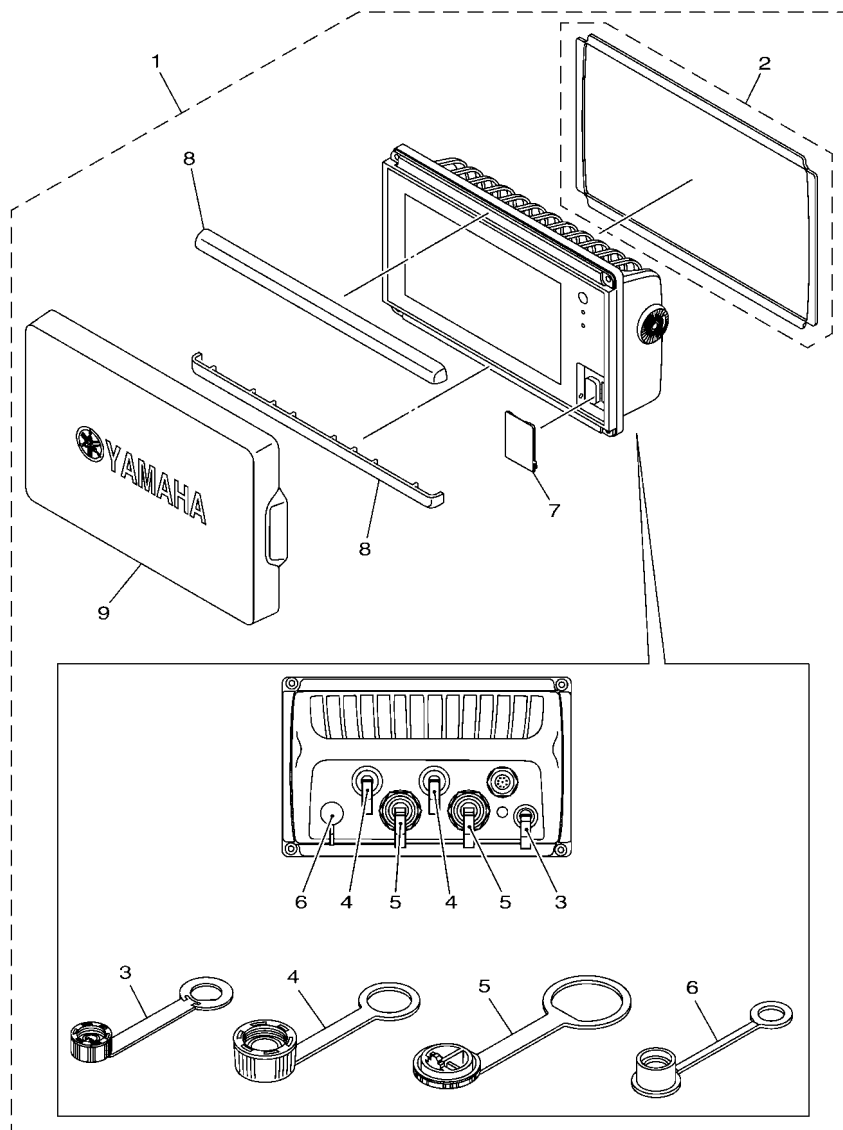

6ES3100-R100

REF. NO.	PART NO.	DESCRIPTION	601M			REMARKS
1	6YD-83710-04	MULTI DISPLAY ASSY	1			UR
	6YD-83710-14	MULTI DISPLAY ASSY	1			UR
	6YD-83710-24	MULTI DISPLAY ASSY	1			UR
2	6YD-22480-00	.SEAL ASSY	1			
3	6YD-83956-00	.CAP 1	1			
4	6YD-83957-00	.CAP 2	2			
5	6YD-83958-00	.CAP 3	2			
6	6YD-82532-00	.CAP	1			
7	6YD-65722-00	.DOOR	1			
8	6YD-83512-00	.RING, SPEED METER	2			
9	6YD-87278-00	.COVER, METER	1			



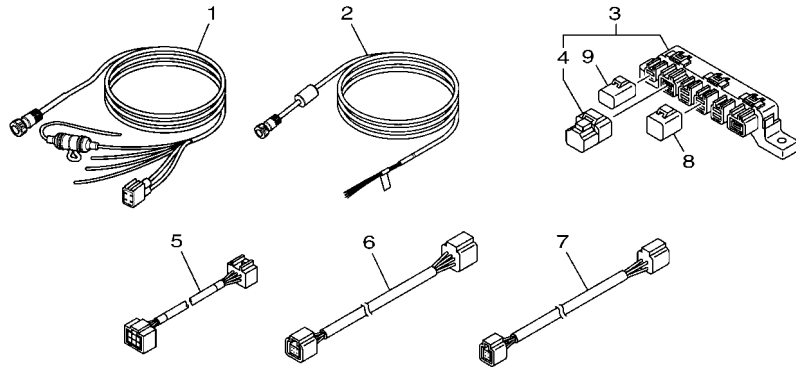
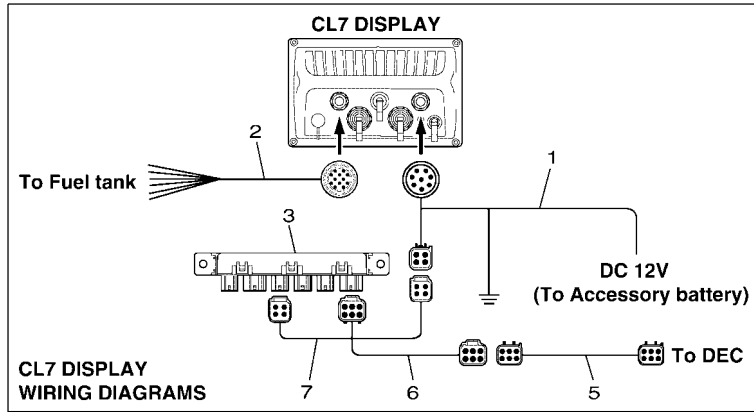

**OPTIONAL EQUIPMENT**

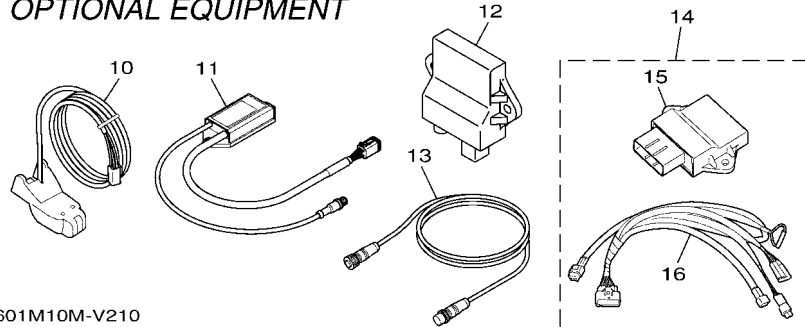

601M10M-V210

**FIG. 21 CL7 DISPLAY 2**

REF. NO.	PART NO.	DESCRIPTION	601M	REMARKS
1	6YD-83553-00	WIRE, LEAD	1	
2	6YD-8356N-00	WIRE, LEAD	1	
3	6Y8-81920-01	MULTI HUB ASSY	1	
4	6Y8-85371-01	.END OF LINE RESISTOR	1	
5	6Y9-83553-00	WIRE, LEAD	1	
6	6Y8-82553-01	1FT MAIN BUS	1	UR
	6Y8-82553-11	15FT MAIN BUS	1	UR
	6Y8-82553-21	20FT MAIN BUS	1	UR
	6Y8-82553-31	25FT MAIN BUS	1	UR
	6Y8-82553-41	30FT MAIN BUS	1	UR
	6Y8-82553-50	10FT MAIN BUS	1	UR
7	6Y8-82521-01	1FT PIGTAIL BUS	1	UR
	6Y8-82521-11	2FT PIGTAIL BUS	1	UR
	6Y8-82521-21	3FT PIGTAIL BUS	1	UR
	6Y8-82521-31	6FT PIGTAIL BUS	1	UR
	6Y8-82521-41	9FT PIGTAIL BUS	1	UR
	6Y8-82521-51	12FT PIGTAIL BUS	1	UR
8	6Y8-82582-11	CAP 1 (4PIN)	1	
9	6Y8-82582-01	CAP 1 (2PIN)	1	
10	6Y9-83688-00	SENSOR ASSY	1	
11	99999-04422	INTERFACE UNIT SET	1	GATEWAY
12	6YG-8A2D0-11	GATEWAY	1	FOR OTHER COMPATIBLE MFD
13	6YG-82521-00	GATEWAY HARNESS	1	
14	6YH-W8A2D-00	INTERFACE UNIT SET	1	ANALOGUE GAUGE
15	6YH-8A2D0-00	.INTERFACE UNIT	1	
16	6YH-82521-00	.WIRE, LEAD	1	

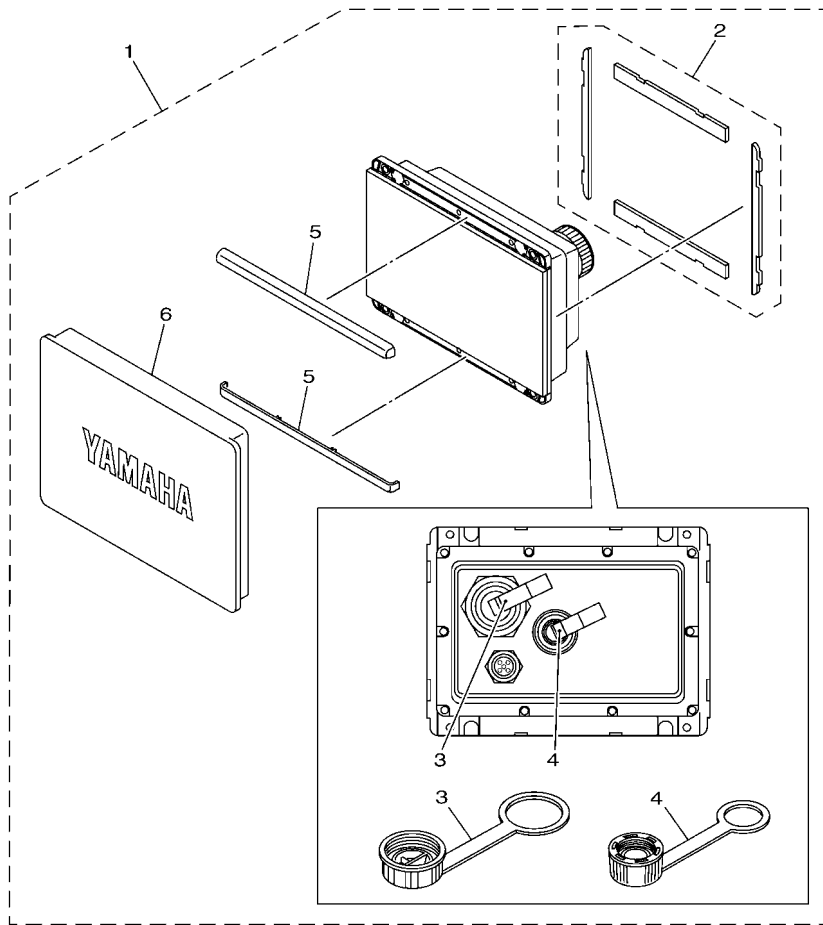

6ALH300-V410

FIG. 22 CL5 DISPLAY 1

REF. NO.	PART NO.	DESCRIPTION	601M				REMARKS
1	6YM-83710-12	CL5 DISPLAY	1				WITHOUT Wi-Fi
2	6YM-22480-00	.SEAL ASSY	1				
3	6YM-83956-00	.CAP 1	1				
4	6YD-83957-00	.CAP 2	1				
5	6YM-83512-00	.RIM	2				
6	6YM-87278-00	.COVER, METER	1				

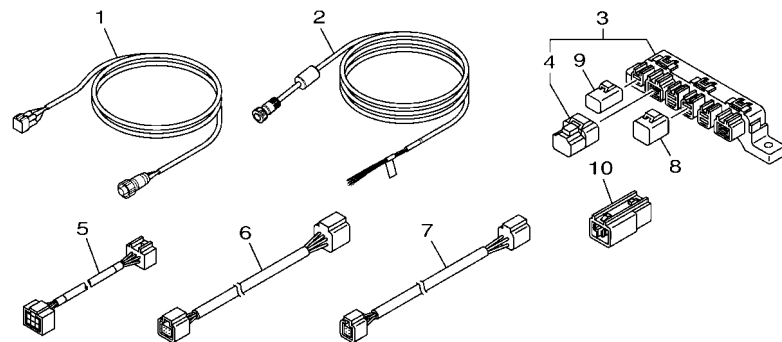
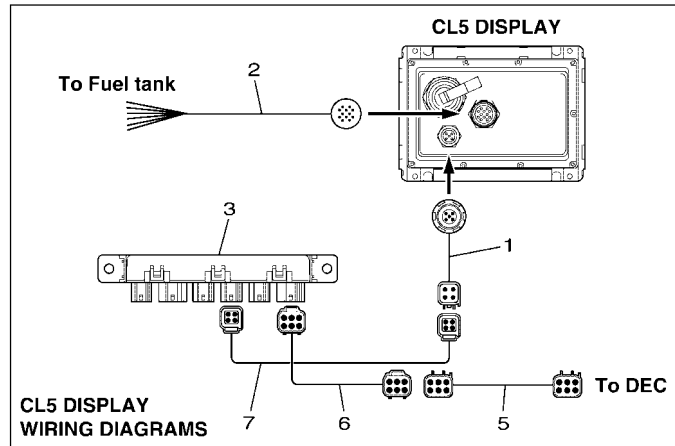

**OPTIONAL EQUIPMENT**

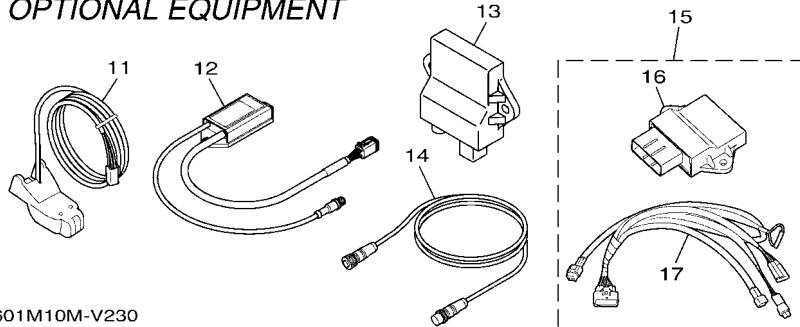

601M10M-V230

**FIG. 23 CL5 DISPLAY 2**

REF. NO.	PART NO.	DESCRIPTION	601M	REMARKS
1	6YM-83553-00	CONVERSION HARNESS	1	
2	6YD-8356N-00	WIRE, LEAD	1	
3	6Y8-81920-01	MULTI HUB ASSY	1	
4	6Y8-85371-01	.END OF LINE RESISTOR	1	
5	6Y9-83553-00	WIRE, LEAD	1	
6	6Y8-82553-01	1FT MAIN BUS	1	UR
	6Y8-82553-11	15FT MAIN BUS	1	UR
	6Y8-82553-21	20FT MAIN BUS	1	UR
	6Y8-82553-31	25FT MAIN BUS	1	UR
	6Y8-82553-41	30FT MAIN BUS	1	UR
	6Y8-82553-50	10FT MAIN BUS	1	UR
7	6Y8-82521-01	1FT PIGTAIL BUS	1	UR
	6Y8-82521-11	2FT PIGTAIL BUS	1	UR
	6Y8-82521-21	3FT PIGTAIL BUS	1	UR
	6Y8-82521-31	6FT PIGTAIL BUS	1	UR
	6Y8-82521-41	9FT PIGTAIL BUS	1	UR
	6Y8-82521-51	12FT PIGTAIL BUS	1	UR
8	6Y8-82582-11	CAP 1 (4PIN)	1	
9	6Y8-82582-01	CAP 1 (2PIN)	1	
10	6Y8-81920-11	IN-LINE HUB ASSY	1	
11	6Y9-83688-00	SENSOR ASSY	1	
12	99999-04422	INTERFACE UNIT SET	1	GATEWAY
13	6YG-8A2D0-11	GATEWAY	1	FOR OTHER COMPATIBLE MFD
14	6YG-82521-00	GATEWAY HARNESS	1	
15	6YH-W8A2D-00	INTERFACE UNIT SET	1	ANALOGUE GAUGE
16	6YH-8A2D0-00	.INTERFACE UNIT	1	
17	6YH-82521-00	.WIRE, LEAD	1	

**SYSTEM POWER  
SUPPLY WIRE**

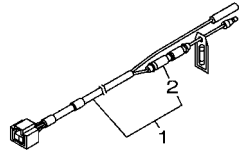

Shared with 6Y8 network system

**IMMOBILIZER POWER  
DISTRIBUTION WIRE 2**

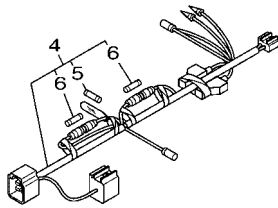

For start/stop button SW panel

**SYSTEM POWER  
DISTRIBUTION WIRE**

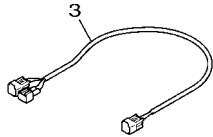

**CONVERSION HARNESS**

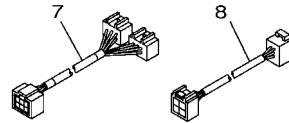

For 6Y9 network system

**CONVERSION HARNESS**

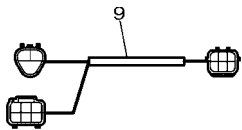

Used to connect between 2nd helm new DEC and 2nd helm previous start/stop SW. (Single engine application)

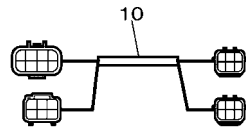

Used to connect between 2nd station helm new DEC and 2nd helm previous start/stop SW. (Twin engine application)

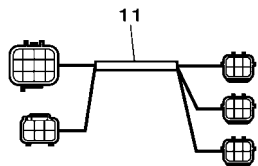

Used to connect between 2nd helm new DEC and 2nd helm previous start/stop SW. (Triple engine application)

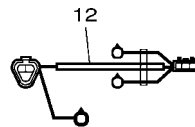

Used to connect between main helm new DEC and 2nd helm previous DEC.

601M10M-V240

**FIG. 24 WIRE HARNESS 3**

REF. NO.	PART NO.	DESCRIPTION	601M				REMARKS
1	6Y8-83553-02	8FT POWER WIRE	1				
2	6G1-82151-01	.FUSE (10A)	1				
3	6Y9-83553-20	WIRE, LEAD	1				
4	6Y8-81315-03	LEAD WIRE ASSY	1				
5	6TA-82151-01	.FUSE(5A)	1				
6	6Y8-82151-00	.FUSE(5A)	2				
7	6Y9-83553-10	WIRE, LEAD	1				
8	6Y9-83553-60	WIRE, LEAD	1				
9	6X6-8258A-M0	EXTENSION, WIRE HARNESS	1				
10	6X6-8258A-N0	EXTENSION, WIRE HARNESS	1				
11	6X6-8258A-P0	EXTENSION, WIRE HARNESS	1				
12	6X6-8258A-K0	EXTENSION, WIRE HARNESS	1				

**FIG. 25 IMMOBILIZER KIT**

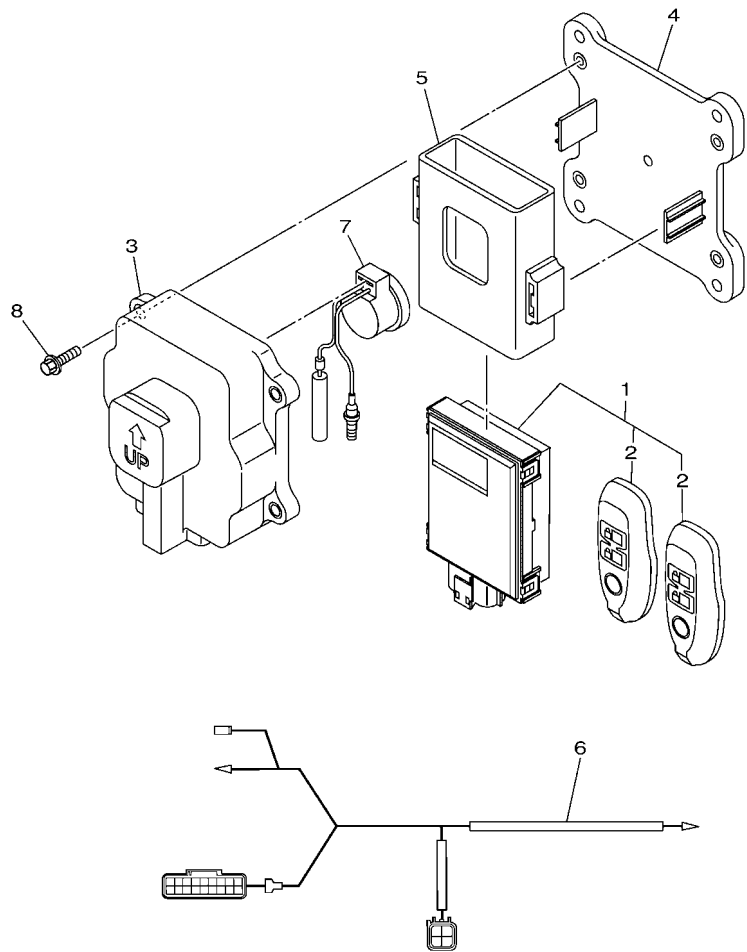

6X91100-U180

REF. NO.	PART NO.	DESCRIPTION	601M				REMARKS
1	6X9-86260-02	REMOTE CONTROL UNIT ASSY	1				UR RADIO FREQUENCY 433MHz
	6X9-86260-12	REMOTE CONTROL UNIT ASSY	1				UR RADIO FREQUENCY 315MHz
2	6X9-86261-00	.XMTR. COMP.	2				FOR 6X9-86260-02
	6X9-86261-10	.XMTR. COMP.	2				FOR 6X9-86260-12
3	6X9-86267-00	CASE COMPLETE 1	1				
4	6X9-81948-00	BRACKET	1				
5	6X9-85546-01	BAND	1				
6	6X9-82509-10	WIRE, SUB LEAD	1				
7	703-83383-11	BUZZER	1				
8	95880-06016	BOLT, FLANGE	4				

FIG. 26 DES

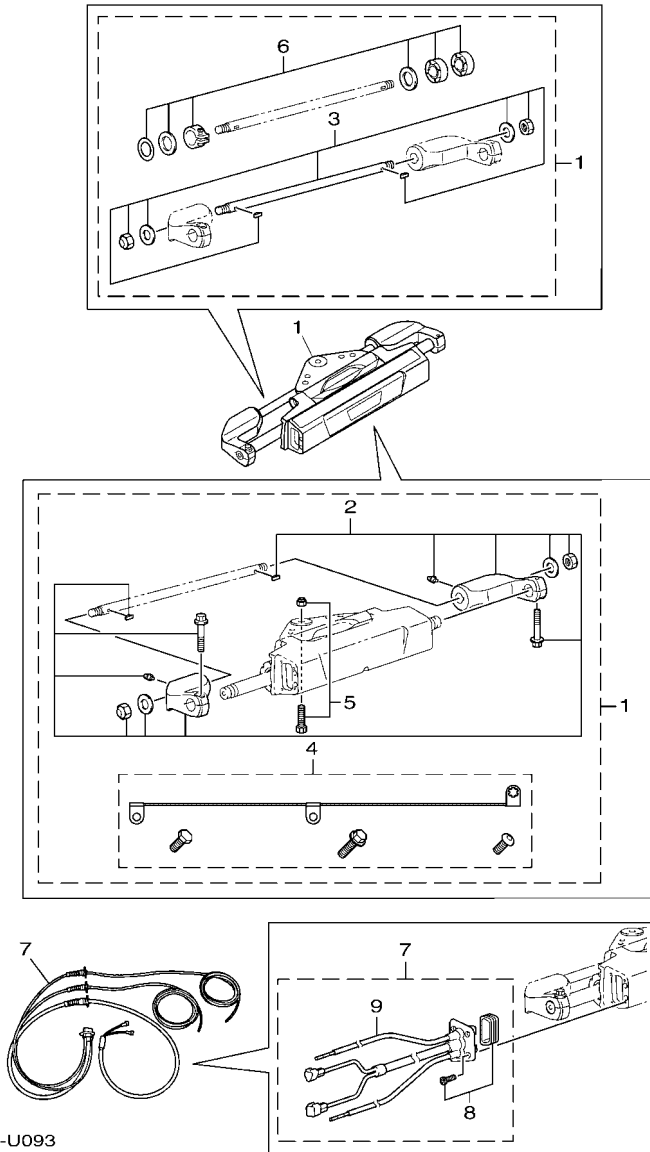

REF. NO.	PART NO.	DESCRIPTION	601M	REMARKS
1	6X9-42401-00	STEERING ACTUATOR	1	
2	6X9-42402-00	.REPAIR KIT, 1	1	
3	6X9-42403-00	.REPAIR KIT, 2	1	
4	6X9-42404-00	.REPAIR KIT, 3	1	
5	6X9-42405-00	.REPAIR KIT, 4	1	
6	6X9-42406-00	.REPAIR KIT, 5	1	
7	6X9-438A0-00	STEERING ACTUATOR HARNESS	1	UR 2.4M-8FT
	6X9-438A0-10	STEERING ACTUATOR HARNESS	1	UR 4.5M-15FT
	6X9-438A0-20	STEERING ACTUATOR U-HARNESS	1	UR 2.4M-8FT
	6X9-438A0-30	STEERING ACTUATOR U-HARNESS	1	UR 4.5M-15FT
	6X9-438A0-40	STEERING ACTUATOR U-HARNESS	1	UR 2.4M-8FT NO BULKHEAD
8	6X9-42407-00	.REPAIR KIT, 6	1	
9	6X9-42408-00	.REPAIR KIT, 7	1	EXCEPT FOR 6X9-438A0-40

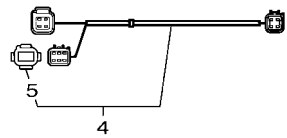
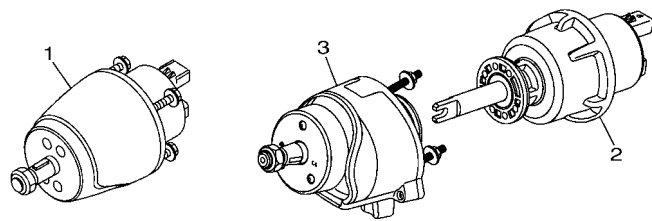

SCU LINK CABLE FOR PORT/STBD

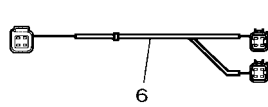

SCU LINK CABLE FOR CENTER

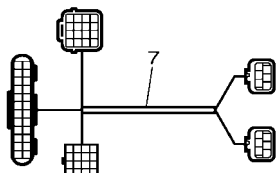

HELM T HARNESS FOR SINGLE

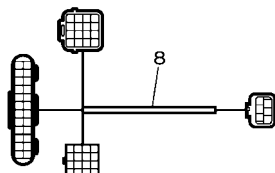

HELM T HARNESS FOR TWIN/TRIPLE/QUAD

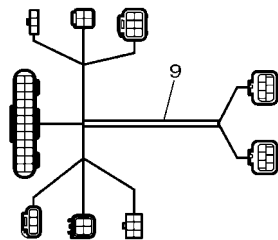

2ND STATION HELM HARNESS FOR SINGLE

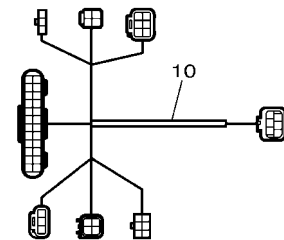

2ND STATION HELM HARNESS FOR TWIN/TRIPLE/QUAD

601M10M-V270 \*1: ASK TO MARINE DIV

FIG. 27 HELM UNIT

REF. NO.	PART NO.	DESCRIPTION	601M	REMARKS
1	6X9-615A0-00	HELM UNIT ASSY	1	
2	6GR-615A0-00	HELM UNIT ASSY	1	ASK TO MARINE DIV
3	6GR-6154A-00	TILT HELM UNIT	1	ASK TO MARINE DIV
4	6X9-81115-00	SCU LINK HARNESS 0.3M-1FT	1	UR *1 PORT/STBD ENGINE
	6GR-81115-00	SCU LINK HARNESS 1.5M-5FT	1	UR *1 PORT/STBD ENGINE
	6GR-81115-10	SCU LINK HARNESS 3.0M-10F	1	UR *1 PORT/STBD ENGINE
5	6Y8-85371-01	.END OF LINE RESISTOR	1	
6	6X9-81115-10	SCU LINK HARNESS (C) 0.3M-1FT	1	UR *1 CENTER ENGINE
	6GR-81115-20	SCU LINK HARNESS (C) 1.5M-5FT	1	UR *1 CENTER ENGINE
	6GR-81115-30	SCU LINK HARNESS (C) 3.0M-10FT	1	UR *1 CENTER ENGINE
7	6GR-8258A-00	HELM HARNESS 0.9M-3FT	1	UR *1 SINGLE ENGINE (MAIN ST)
	6GR-8258A-40	HELM HARNESS 1.8M-6FT	1	UR *1 SINGLE ENGINE (MAIN ST)
8	6GR-8258A-10	HELM HARNESS 0.9M-3FT	2	UR *1 MULTIPLE ENGINES (MAIN ST)
	6GR-8258A-50	HELM HARNESS 1.8M-6FT	2	UR *1 MULTIPLE ENGINES (MAIN ST)
9	6GR-8258A-20	EXTENSION, WIRE HARNESS	1	*1 SINGLE ENGINE
10	6GR-8258A-30	EXTENSION, WIRE HARNESS	2	*1 MULTIPLE ENGIN

NUMERICAL INDEX

PART NO.	REF. NO.	PART NO.	REF. NO.	PART NO.	REF. NO.	PART NO.	REF. NO.	PART NO.	REF. NO.	PART NO.	REF. NO.
6YD-22480-00	20 - 2	6G1-82151-01	9 - 9	6Y8-82553-41	23 - 6	6Y8-83514-00	12 - 3	6Y5-83570-A0	3 - 1	6Y8-83688-11	12 - 5
6YM-22480-00	22 - 2		9 - 11	6R3-82553-50	10 - 3	6Y5-83517-00	4 - 2	6Y5-83577-00	7 - 9	6YD-83710-04	20 - 1
6H4-24311-00	19 - 6		13 - 10	6Y8-82553-50	13 - 7	6Y5-83518-00	6 - 2	6Y7-83590-00	7 - 1	6YM-83710-12	22 - 1
6X9-42401-00	26 - 1		24 - 2		21 - 6		6 - 7	6Y7-83590-10	7 - 1	6YD-83710-14	20 - 1
6X9-42402-00	26 - 2	6TA-82151-01	24 - 5		23 - 6		7 - 2	688-83591-00	7 - 6	6YD-83710-24	20 - 1
6X9-42403-00	26 - 3	6X9-82509-10	25 - 6	6R3-82553-70	10 - 3		7 - 11	6P2-83652-00	19 - 4	6Y5-83728-00	3 - 5
6X9-42404-00	26 - 4	688-82520-00	10 - 1	6R3-82553-80	10 - 3		8 - 5	6Y5-83653-00	10 - 4	6P2-83728-01	19 - 1
6X9-42405-00	26 - 5	6YG-82521-00	21 - 13	6R3-82553-90	10 - 3		8 - 7	6Y5-83653-10	10 - 4	6YD-83956-00	20 - 3
6X9-42406-00	26 - 6		23 - 14	60V-8257V-00	14 - 10	6Y5-83523-00	4 - 4	6Y5-83653-20	10 - 4	6YM-83956-00	22 - 3
6X9-42407-00	26 - 8	6YH-82521-00	12 - 10		18 - 10	6Y5-83536-00	6 - 3	6Y5-83653-30	10 - 4	6YD-83957-00	20 - 4
6X9-42408-00	26 - 9		21 - 16	6Y8-82582-01	13 - 5		6 - 8	6Y5-83653-40	10 - 4		22 - 4
60V-42629-01	16 - 8		23 - 17		21 - 9		7 - 3	6Y5-83653-50	10 - 4	6YD-83958-00	20 - 5
	17 - 10	6Y8-82521-01	13 - 8		23 - 9		7 - 10	6Y7-83660-00	6 - 6	663-84301-01	11 - 1
	18 - 19		21 - 7	6Y8-82582-11	13 - 6		8 - 4	6Y7-83660-10	6 - 6	682-84380-00	10 - 6
6X9-438A0-00	26 - 7		23 - 7		21 - 8		8 - 8	6Y7-83660-30	6 - 6	682-84381-00	10 - 7
6X9-438A0-10	26 - 7	6Y8-82521-11	13 - 8		23 - 8	6Y5-83536-40	4 - 3	688-83664-00	6 - 5	682-84382-00	10 - 8
6X9-438A0-20	26 - 7		21 - 7	6GR-8258A-00	27 - 7	6Y7-83540-21	2 - 1		6 - 9	6Y8-84383-00	1 - 3
6X9-438A0-30	26 - 7		23 - 7	6GR-8258A-10	27 - 8	6Y7-83540-51	2 - 2		7 - 4		3 - 2
6X9-438A0-40	26 - 7	6Y8-82521-21	13 - 8	6GR-8258A-20	27 - 9	6Y7-83540-81	2 - 2		7 - 8		5 - 3
6GR-6154A-00	27 - 3		21 - 7	6GR-8258A-30	27 - 10	6Y7-83540-91	2 - 2		8 - 3	6Y8-85371-01	13 - 3
6GR-615A0-00	27 - 2		23 - 7	6GR-8258A-40	27 - 7	6Y5-83544-00	6 - 4		8 - 9		21 - 4
6X9-615A0-00	27 - 1	6Y8-82521-31	13 - 8	6GR-8258A-50	27 - 8		7 - 5	688-83665-00	6 - 10		23 - 4
6YD-65722-00	20 - 7		21 - 7	6X6-8258A-K0	24 - 12		8 - 2	688-83666-00	6 - 13		27 - 5
6GR-81115-00	27 - 4		23 - 7	6X6-8258A-M0	24 - 9		8 - 10	60V-83667-00	14 - 4	6X9-85546-01	25 - 5
6X9-81115-00	27 - 4	6Y8-82521-41	13 - 8	6X6-8258A-N0	24 - 10	6Y9-83553-00	21 - 5		18 - 5	6Y5-85721-F0	5 - 9
6GR-81115-10	27 - 4		21 - 7	6X6-8258A-P0	24 - 11		23 - 5	688-83667-01	6 - 12	6Y7-85750-00	8 - 6
6X9-81115-10	27 - 6		23 - 7	703-83383-11	25 - 7	6YD-83553-00	21 - 1	663-83668-00	6 - 11	6Y7-85750-10	8 - 6
6GR-81115-20	27 - 6	6Y8-82521-51	13 - 8	6Y8-83500-21	12 - 2	6YM-83553-00	23 - 1	663-83668-10	6 - 14	6Y7-85750-20	8 - 6
6GR-81115-30	27 - 6		21 - 7	6Y7-83503-00	8 - 1	6Y5-83553-01	9 - 3	6AW-8366B-02	14 - 9	6Y7-85750-30	8 - 6
6H5-81315-00	11 - 2		23 - 7	6Y7-83503-10	8 - 1	6Y8-83553-02	13 - 9		15 - 2	6Y5-85752-02	5 - 6
6Y8-81315-03	24 - 4	688-82526-00	10 - 2	6Y7-83504-00	7 - 14		24 - 1		16 - 2	6X9-86260-02	25 - 1
6Y8-81920-01	13 - 2	703-82531-00	9 - 2	6Y5-83504-01	7 - 7	6Y5-83553-10	9 - 5		17 - 2	6X9-86260-12	25 - 1
	21 - 3	6YD-82532-00	20 - 6	6Y7-83504-10	7 - 14	6Y9-83553-10	24 - 7		18 - 2	6X9-86261-00	25 - 2
	23 - 3	6Y8-82553-01	13 - 7	6Y5-8350F-B0	5 - 2	6Y9-83553-20	24 - 3	63P-8366C-00	15 - 3	6X9-86261-10	25 - 2
6Y8-81920-11	13 - 4		21 - 6	6Y8-8350T-21	12 - 1	6Y5-83553-21	9 - 6		17 - 3	6X9-86267-00	25 - 3
	23 - 10		23 - 6	6Y5-8350T-E0	1 - 1	6Y9-83553-60	24 - 8	60V-8366D-00	14 - 2	6Y5-87122-S0	3 - 3
6X9-81948-00	25 - 4	6Y8-82553-11	13 - 7	6Y5-8350U-10	10 - 9	6Y5-83553-F1	5 - 5		16 - 3		5 - 4
6KW-81949-00	11 - 3		21 - 6	6Y7-83510-00	4 - 1		10 - 5		17 - 5	6YD-87278-00	20 - 9
68F-81949-03	11 - 3		23 - 6	6Y7-83510-10	4 - 1	6Y5-83553-M1	9 - 8		18 - 3	6YM-87278-00	22 - 6
69J-81949-03	11 - 3	6Y8-82553-21	13 - 7	6Y7-83510-20	4 - 1	6Y5-83553-N1	9 - 10		18 - 14	6YH-8A2D0-00	12 - 9
676-81970-02	10 - 10		21 - 6	6Y7-83510-30	4 - 1	688-83557-00	4 - 6	6Y7-83670-00	6 - 1		21 - 15
6Y5-82117-00	5 - 8		23 - 6	6Y7-83510-40	4 - 1	6Y5-83557-00	3 - 7	6Y7-83670-20	6 - 1		23 - 16
	9 - 1	6R3-82553-30	10 - 3	6Y7-83510-50	4 - 1	6Y5-83557-31	3 - 4	6Y7-83670-40	6 - 1	6YG-8A2D0-11	21 - 12
6Y5-82149-00	9 - 1	6Y8-82553-31	13 - 7	6Y7-83510-60	4 - 1	6Y5-8355X-H0	7 - 15	6Y7-83670-50	6 - 1		23 - 13
6Y8-82151-00	24 - 6		21 - 6	6Y7-83510-70	4 - 1	6Y5-8356N-00	9 - 12	6Y9-83688-00	12 - 6	63P-8A4L0-06	15 - 1
663-82151-01	10 - 11		23 - 6	6YD-83512-00	20 - 8	6YD-8356N-00	21 - 2		21 - 10	63P-8A4L0-11	15 - 1
6G1-82151-01	9 - 4	6Y8-82553-41	13 - 7	6YM-83512-00	22 - 5		23 - 2		23 - 11	60V-8A4L0-1A	14 - 1
	9 - 7		21 - 6	6Y5-83514-00	4 - 5	6Y8-8356N-01	13 - 1	6Y8-83688-01	12 - 4	60V-8A4L1-1B	16 - 1



NUMERICAL INDEX

PART NO.	REF. NO.	PART NO.	REF. NO.	PART NO.	REF. NO.	PART NO.	REF. NO.	PART NO.	REF. NO.	PART NO.	REF. NO.
63P-8A4L2-06	17 - 1	97880-05025	10 - 13								
60V-8A4L2-07	18 - 1	97E95-06516	14 - 11								
6Y5-W0088-55	5 - 1		16 - 9								
6YH-W8A2D-00	12 - 8		17 - 11								
	21 - 14		18 - 11								
	23 - 15		18 - 20								
90109-06M81	14 - 13	97E95-06530	19 - 5								
	16 - 4	99999-04422	12 - 7								
	17 - 6		21 - 11								
	18 - 13		23 - 12								
	18 - 15	9E450-04533	1 - 2								
90158-06003	5 - 7										
90340-14M06	19 - 2										
90430-14115	14 - 5										
	15 - 4										
	17 - 4										
	18 - 6										
	19 - 3										
90445-07017	16 - 6										
	17 - 8										
	18 - 17										
90445-07018	14 - 6										
	18 - 7										
90447-07013	16 - 7										
	17 - 9										
	18 - 18										
90447-07015	14 - 7										
	18 - 8										
90464-09021	14 - 12										
	18 - 12										
90465-11M10	3 - 6										
	3 - 8										
	4 - 7										
	14 - 8										
	16 - 5										
	17 - 7										
	18 - 9										
	18 - 16										
90467-08M18	19 - 7										
92903-06600	10 - 15										
92990-04100	7 - 13										
	7 - 16										
95303-04600	7 - 12										
95380-04600	7 - 17										
95880-06016	25 - 8										
95D95-06025	14 - 3										
	18 - 4										
97013-06010	10 - 14										