



PARTS CATALOGUE

RIGGING-METER

RIGGING-METER
PARTS CATALOGUE
©2011 by Yamaha Motor Co., Ltd.
1st edition, November 2011
All rights reserved.
Any reprinting or unauthorized use
without the written permission of
Yamaha Motor Co., Ltd.
is expressly prohibited.
Printed in Japan.

FOREWORD

This Parts Catalogue is related to the parts for the model(s) on the cover page. When you are ordering replacement parts, please refer to this Parts Catalogue and quote both part numbers and part names correctly.

1. Modifications or additions which have been made after the issue of the Parts Catalogue will be announced in the Parts News.

It is advisable that you make the necessary corrections to the Parts Catalogue according to the Parts News.

2. Abbreviations

The following abbreviations are used in this Parts Catalogue.

“UR” Use specified parts number.

“UN” Use as many as needed.

“AP” Alternate Parts

“LM” Locally Made (Parts need to be ordered locally)

“F#” Frame No. (Applicable machine No.)

“O/S” Over Size

3. The number of components for assembly

- Parts, which are to be supplied in an assembly, are listed with a dot (.) in front of the part name as shown below.
- The numeral appearing to the right of each component part indicates the quantity of parts for each assembly unit.

PART NO.	DESCRIPTION	Q'TY	REMARKS
2F5-83310-60	FRONT FLASHER LIGHT ASSY	2	
115-83311-60	.BULB (6V-18W)	1	

4. Applicable colours of graphics are represented in the “REMARKS” as shown below.

PART NO.	DESCRIPTION	Q'TY	REMARKS
2N4-24110-00-X5	FUEL TANK COMP.	2	MXR
3J1-24240-10	.GRAPHIC, FUEL TANK	1	FOR MXR

5. Note that the illustrations for reference in finding parts numbers are not to be used for assembling. When assembling, please use the applicable service manual.

6. The asterisk (*) before a reference number indicates modified items after the first edition.

CONTENTS

METER 1	1
METER 2	2
METER 3	4
METER 4	5
METER 5	6
METER 6	7
METER 7	8
METER 8	9
WIRE HARNESS 1	10
WIRE HARNESS 2	11
ELECTRICAL	13
DIGITAL NETWORK GAUGE 1	14
DIGITAL NETWORK GAUGE 2	15
DIGITAL NETWORK GAUGE 3	17
DIGITAL NETWORK GAUGE 4	18
DIGITAL NETWORK GAUGE 5	19
DIGITAL NETWORK GAUGE 6	20
DIGITAL NETWORK GAUGE 7	21
COMMAND LINK PLUS	22
INDEX	
NUMERICAL INDEX	23

DIGITAL TACHOMETER

Ref. No.	Description	Part No.	Applicable model
1	Multifunction	6Y5-8350T-03	250G,L250G
7	Multifunction w/o "Check engine" and "Water in fuel" indicators	6Y5-8350T-90	Above 40 (3-cyl) w/ oil injection & PTT (except 250G/L250G), Above F30 w/ PTT (*1)

(*1) Mechanical RC

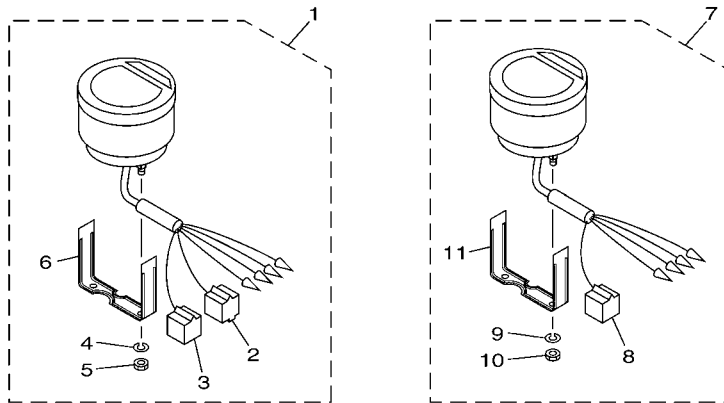

FIG. 1 METER 1

REF. NO.	PART NO.	DESCRIPTION	601M				REMARKS
1	6Y5-8350T-03	DIGITAL TACHOMETER ASSY	1				
2	9E450-04433	.CONNECTOR	1				M-4-W
3	9E450-04533	.CONNECTOR	1				F-4-W
4	92990-04100	.WASHER, SPRING	2				
5	95380-04600	.NUT	2				
6	6Y5-8355X-T1	.BRACKET, METER 1	1				
7	6Y5-8350T-90	DIGITAL TACHOMETER ASSY	1				
8	9E450-04533	.CONNECTOR	1				F-4-W
9	92990-04100	.WASHER, SPRING	2				
10	95380-04600	.NUT	2				
11	6Y5-8355X-T1	.BRACKET, METER 1	1				

601M10M-K010

ANALOG TACHOMETER

Ref. No.	Description	Part No.	Applicable model
1	Without indicators BLK panel	6Y7-83540-20	Pre-mixed 9.9-225 F9.9-F25(FT/T25), and FT8 (T8)
	Without indicators WHT panel	6Y7-83540-30	
8	With 3 oil indicators BLK panel	6Y7-83540-00	250G, L250G
	With 3 oil indicators WHT panel	6Y7-83540-10	
17	With overheat & oil indicators BLK panel	6Y7-83540-80	Above 40 (3-cyl) w/ oil injection (except 250G/ L250G) Above F30 [Mechanical RC]
	With overheat & oil indicators WHT panel	6Y7-83540-90	

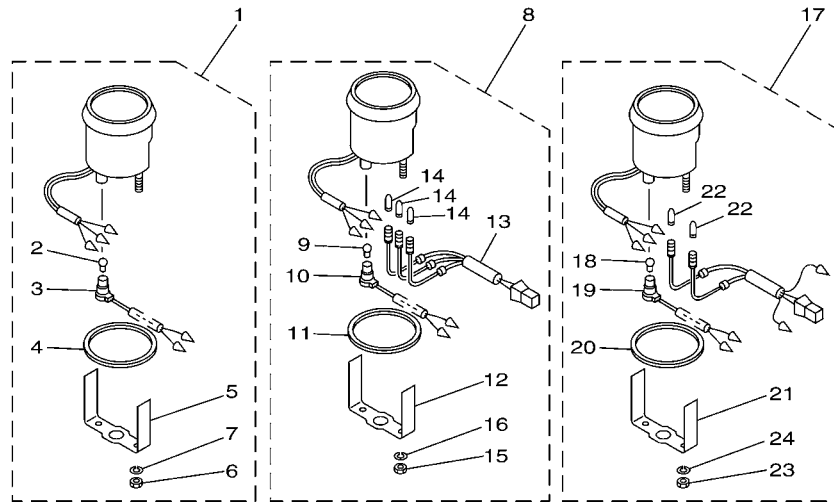

601M10M-K020

FIG. 2 METER 2

REF. NO.	PART NO.	DESCRIPTION	601M				REMARKS
1	6Y7-83540-20	TACHOMETER ASSY	1				UR WITHOUT OIL LAMP
	6Y7-83540-30	TACHOMETER ASSY	1				UR WITHOUT OIL LAMP
2	6Y5-83517-00	.BULB (T10, 12V-1.7W)	1				
3	6Y5-83536-40	.SOCKET, METER	1				FOR 6Y7-83540-20
	6Y5-83536-10	.SOCKET, METER	1				FOR 6Y7-83540-30
4	6Y5-83523-00	.DAMPER	1				
5	6Y5-83514-00	.PLATE, FITTING	1				
6	95380-05600	.NUT	2				
7	92990-05100	.WASHER, SPRING	2				
8	6Y7-83540-00	TACHOMETER ASSY	1				UR WITH OIL LAMP
	6Y7-83540-10	TACHOMETER ASSY	1				UR WITH OIL LAMP
9	6Y5-83517-00	.BULB (T10, 12V-1.7W)	1				
10	6Y5-83536-40	.SOCKET, METER	1				
11	6Y5-83523-00	.DAMPER	1				
12	6Y5-83514-00	.PLATE, FITTING	1				
13	6Y5-83509-03	.SOCKET CORD ASSY	1				
14	6Y5-83518-00	.BULB (12V-1.7W T6.5)	3				
15	95303-05600	.NUT	2				
16	92903-05100	.WASHER, SPRING	2				
17	6Y7-83540-80	TACHOMETER ASSY	1				UR WITH OIL/TEMP LAMP
	6Y7-83540-90	TACHOMETER ASSY	1				UR WITH OIL/TEMP LAMP
18	6Y5-83517-00	.BULB (T10, 12V-1.7W)	1				
19	6Y5-83536-40	.SOCKET, METER	1				
20	6Y5-83523-00	.DAMPER	1				
21	6Y5-83514-00	.PLATE, FITTING	1				
22	6Y5-83518-00	.BULB (12V-1.7W T6.5)	2				
23	95380-05600	.NUT	2				

ANALOG TACHOMETER

Ref. No.	Description	Part No.	Applicable model
1	Without indicators BLK panel	6Y7-83540-20	Pre-mixed 9.9-225 F9.9-F25(FT/T25), and FT8 (T8)
	Without indicators WHT panel	6Y7-83540-30	
8	With 3 oil indicators BLK panel	6Y7-83540-00	250G, L250G
	With 3 oil indicators WHT panel	6Y7-83540-10	
17	With overheat & oil indicators BLK panel	6Y7-83540-80	Above 40 (3-cyl) w/ oil injection (except 250G/ L250G) Above F30 [Mechanical RC]
	With overheat & oil indicators WHT panel	6Y7-83540-90	

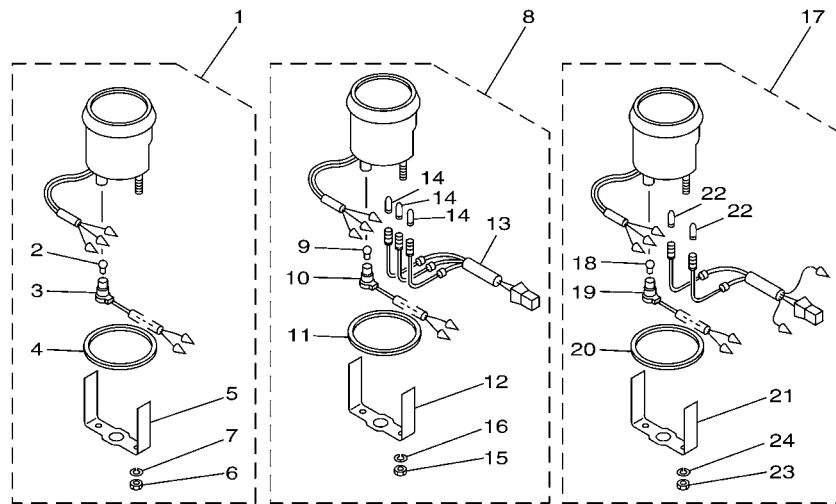

601M10M-K020

FIG. 2 METER 2

REF. NO.	PART NO.	DESCRIPTION	601M			REMARKS
24	92990-05100	.WASHER, SPRING	2			

DIGITAL SPEEDOMETER

Ref. No.	Description	Part No.	Applicable model
1	Digital multifunction	6Y5-83570-S5	Above 40 (3-cyl) Above F30 [Mechanical RC]
10		6Y5-83500-30	For Yamaha manufactured boats (Japan)

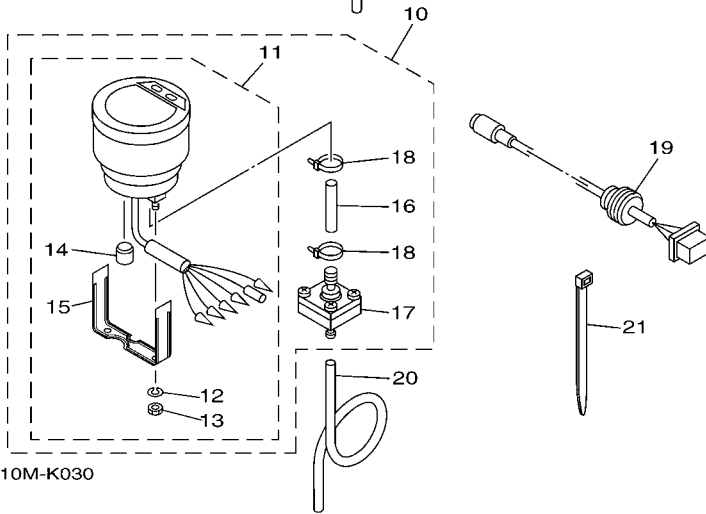
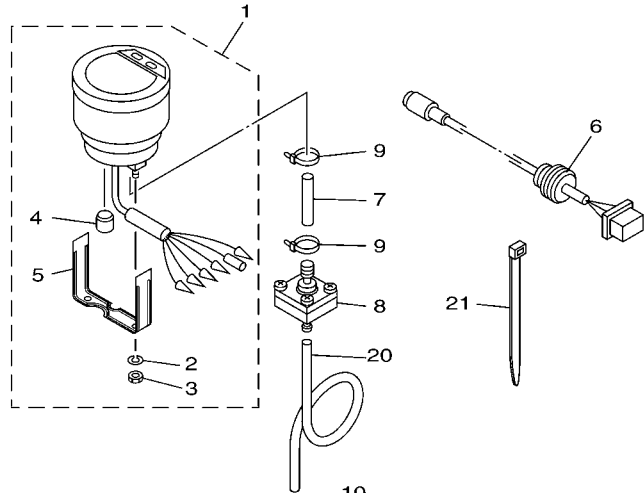

601M10M-K030

FIG. 3 METER 3

REF. NO.	PART NO.	DESCRIPTION	601M				REMARKS
1	6Y5-83570-S5	SPEEDOMETER ASSY	1				
2	92990-04100	.WASHER, SPRING	2				
3	95380-04600	.NUT	2				
4	6Y5-83533-T2	.GROMMET	1				
5	6Y5-8355X-T1	.BRACKET, METER 1	1				
6	6Y5-87122-S0	CORD ASSY 1	1				AP
7	6Y5-83557-31	TUBE	1				
8	6Y5-83728-00	CONNECTOR ASSY	1				
9	90465-11M10	CLAMP	2				
10	6Y5-83500-30	METER ASSY	1				
11	6Y5-83570-30	.SPEEDOMETER ASSY	1				
12	92990-04100	..WASHER, SPRING	2				
13	95380-04600	..NUT	2				
14	6Y5-83533-T2	..GROMMET	1				
15	6Y5-8355X-T1	..BRACKET, METER 1	1				
16	6Y5-83557-31	.TUBE	1				
17	6Y5-83728-00	.CONNECTOR ASSY	1				
18	90465-11M10	.CLAMP	2				
19	6Y5-87122-S0	CORD ASSY 1	1				AP
20	6Y5-83557-00	TUBE (6M)	1				
21	90465-11M10	CLAMP	2				

ANALOG SPEEDOMETER

Description	Part No.	Applicable model
Analog, BLK panel 0 - 75 mph (20 - 120 km/h)	6Y7-83510-00	Above 40 (3-cyl) Above F30 [Mechanical RC]
Analog, WHT panel 0 - 75 mph (20 - 120 km/h)	6Y7-83510-10	
Analog, BLK panel 0 - 50 mph (20 - 80 km/h)	6Y7-83510-20	
Analog, WHT panel 0 - 50 mph (20 - 80 km/h)	6Y7-83510-30	
Analog, BLK panel 0 - 120 km/h (15 - 65 knot)	6Y7-83510-40	
Analog, WHT panel 0 - 120 km/h (15 - 65 knot)	6Y7-83510-50	
Analog, BLK panel 0 - 80 km/h (10 - 43 knot)	6Y7-83510-60	
Analog, WHT panel 0 - 80 km/h (10 - 43 knot)	6Y7-83510-70	

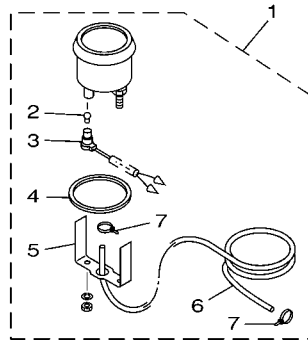

601M10M-K040

FIG. 4 METER 4

REF. NO.	PART NO.	DESCRIPTION	601M				REMARKS
1	6Y7-83510-00	SPEEDOMETER ASSY (75MPH)	1				UR
	6Y7-83510-10	SPEEDOMETER ASSY (75MPH)	1				UR
	6Y7-83510-20	SPEEDOMETER ASSY (50MPH)	1				UR
	6Y7-83510-30	SPEEDOMETER ASSY (50MPH)	1				UR
	6Y7-83510-40	SPEEDOMETER ASSY (120KM/H)	1				UR
	6Y7-83510-50	SPEEDOMETER ASSY (120KM/H)	1				UR
	6Y7-83510-60	SPEEDOMETER ASSY (80KM/H)	1				UR
	6Y7-83510-70	SPEEDOMETER ASSY (80KM/H)	1				UR
2	6Y5-83517-00	.BULB (T10, 12V-1.7W)	1				
3	6Y5-83536-40	.SOCKET, METER	1				
4	6Y5-83523-00	.DAMPER	1				
5	6Y5-83514-00	.PLATE, FITTING	1				
6	688-83557-00	.TUBE	1				
7	90465-11M10	.CLAMP	2				

FUEL MANAGEMENT GAUGE

Ref. No.	Description	Part No.	Applicable model
1	Fuel mgt gauge kit 1 For single-engine	6Y5-W0088-54	Above 115 Above F115 [Mechanical RC]
	Fuel mgt gauge kit 2 For twin-engine	6Y5-W0088-65	
12	Fuel mgt gauge with speedometer	6Y5-83500-40	

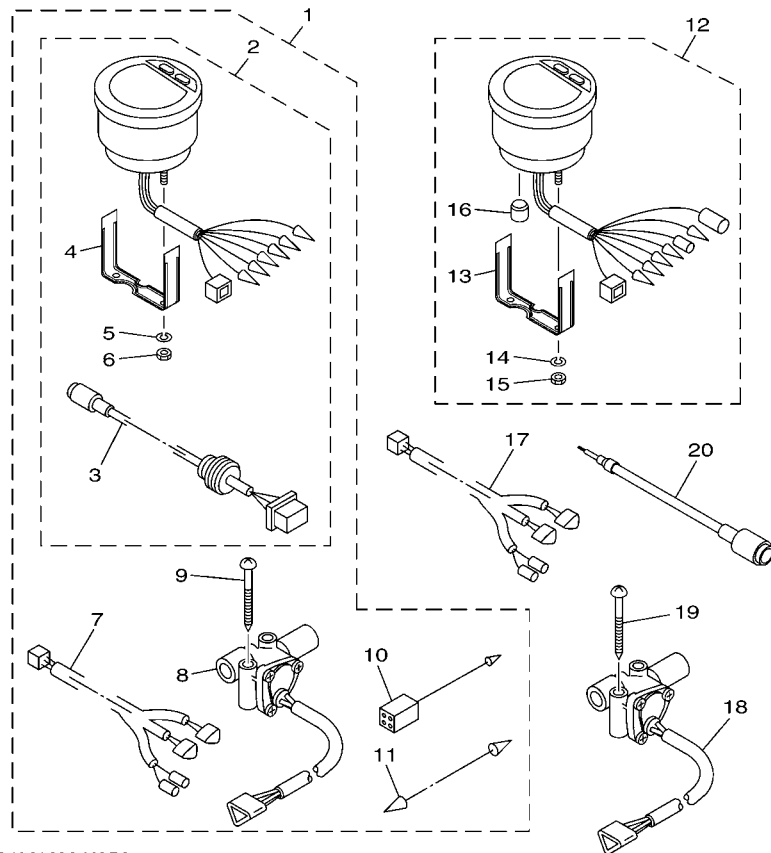

601M10M-K050

FIG. 5 METER 5

REF. NO.	PART NO.	DESCRIPTION	601M				REMARKS
1	6Y5-W0088-54	DIGITAL FUEL METER KIT(SINGLE)	1				UR
	6Y5-W0088-65	DIGITAL FUEL METER KIT (TWIN)	1				UR
2	6Y5-83500-F2	.FUEL MANAGEMENT METER	1				
3	6Y5-87122-S0	..CORD ASSY 1	1				
4	6Y5-8355X-T1	..BRACKET, METER 1	1				
5	92990-04100	..WASHER, SPRING	2				
6	95380-04600	..NUT	2				
7	6Y5-83553-F1	.WIRE, LEAD (L=8.0M)	1				
8	6Y5-85752-02	.SENDER UNIT ASSY, FUEL METER	1				FOR 6Y5-W0088-54
	6Y5-85752-02	.SENDER UNIT ASSY, FUEL METER	2				FOR 6Y5-W0088-65
9	90158-06003	.SCREW, WOOD	2				FOR 6Y5-W0088-54
	90158-06003	.SCREW, WOOD	4				FOR 6Y5-W0088-65
10	6Y5-82117-00	.WIRE, LEAD (BLACK) (L300)	1				
11	703-82531-00	.WIRE, LEAD (L70)	1				FOR 6Y5-W0088-65
12	6Y5-83500-40	METER ASSY	1				
13	6Y5-8355X-T1	.BRACKET, METER 1	1				
14	92990-04100	.WASHER, SPRING	2				
15	95380-04600	.NUT	2				
16	6Y5-83533-T2	.GROMMET	1				
17	6Y5-83553-F1	WIRE, LEAD (L=8.0M)	1				FOR 6Y5-83500-40
18	6Y5-85752-02	SENDER UNIT ASSY, FUEL METER	1				FOR 6Y5-83500-40
19	90158-06003	SCREW, WOOD	2				FOR 6Y5-83500-40
20	6Y5-85721-F0	WIRE, LEAD	1				AP

ANALOG TRIM METER

Description	Part No.	Applicable model
4-pin coupler BLK panel	6Y7-83670-00	Above premixed 40 (3-cyl) w/ PTT, 250G, L250G
Bullet connector BLK panel	6Y7-83670-40	Above 40 (3-cyl) w/ oil injection & PTT (except 250G & L250G), Above F30 w/ PTT (*1), T25 (*2) Using as a set with tachometer, 6Y7-83540-80
4-pin coupler WHT panel	6Y7-83670-20	Premixed 40 (3-cyl)-225 w/ PTT, 250G, L250G
Bullet connector WHT panel	6Y7-83670-50	Above 40 (3-cyl) w/ oil injection & PTT (except 250G & L250G), Above F30 w/ PTT (*1), T25 (*2) Using as a set with tachometer, 6Y7-83540-80

(*1) Mechanical RC
(*2) T25 for US/CA

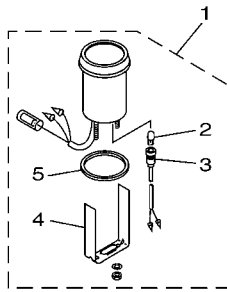

COOLANT PRESSURE METER

Description	Part No.	Applicable model
kPa, Black panel	6Y7-83660-00	Above 40 [3-cyl] Above F25 (FT/T25) [Mechanical RC]
kPa, White panel	6Y7-83660-20	
psi, Black panel	6Y7-83660-10	
psi, White panel	6Y7-83660-30	

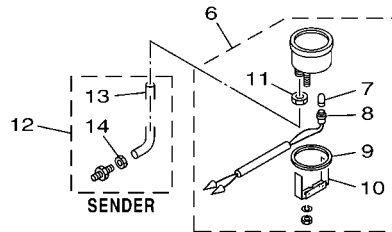

601M10M-K060

FIG. 6 METER 6

REF. NO.	PART NO.	DESCRIPTION	601M	REMARKS
1	6Y7-83670-00	TRIM METER ASSY.	1	UR
	6Y7-83670-40	TRIM METER ASSY.	1	UR
	6Y7-83670-20	TRIM METER ASSY.	1	UR
	6Y7-83670-50	TRIM METER ASSY.	1	UR
2	6Y5-83518-00	.BULB (12V-1.7W T6.5)	1	
3	6Y5-83536-00	.SOCKET, METER	1	
4	6Y5-83544-00	.PLATE, FITTING	1	
5	688-83664-00	.DAMPER	1	
6	6Y7-83660-00	WATER PRESSURE METER ASSY	1	UR
	6Y7-83660-20	WATER PRESSURE METER ASSY	1	UR
	6Y7-83660-10	WATER PRESSURE METER ASSY	1	UR
	6Y7-83660-30	WATER PRESSURE METER ASSY	1	UR
7	6Y5-83518-00	.BULB (12V-1.7W T6.5)	1	
8	6Y5-83536-00	.SOCKET, METER	1	
9	688-83664-00	.DAMPER	1	
10	688-83665-00	.PLATE, FITTING	1	
11	663-83668-00	.NUT, NIPPLE	1	
12	688-83667-00	SENDER	1	
13	688-83666-00	.TUBE	1	
14	663-83668-00	.NUT, NIPPLE	1	

COOLANT TEMP. METER

Description	Part No.	Applicable model
Black panel	6Y7-83590-00	Above 40 [3-cylinder]
White panel	6Y7-83590-10	Above F25 (FT/T25) [Mechanical RC]

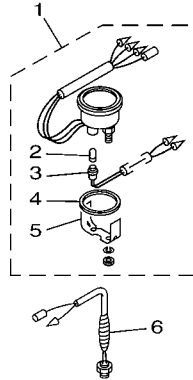

HOUR METER

Ref. No.	Description	Part No.	Applicable model
7	Mechanical	6Y5-83504-01	All electrical start models
14	Digital, Black panel	6Y7-83504-00	
	Digital, White panel	6Y7-83504-10	

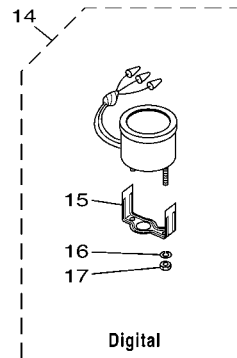
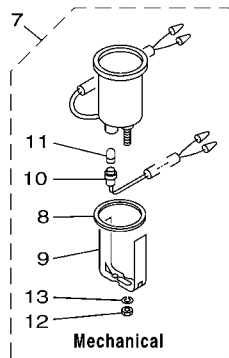

601M10M-K070

FIG. 7 METER 7

REF. NO.	PART NO.	DESCRIPTION	601M				REMARKS
1	6Y7-83590-00	WATER TEMPERATURE ASSY	1				UR
	6Y7-83590-10	WATER TEMPERATURE ASSY	1				UR
2	6Y5-83518-00	.BULB (12V-1.7W T6.5)	1				
3	6Y5-83536-00	.SOCKET, METER	1				
4	688-83664-00	.DAMPER	1				
5	6Y5-83544-00	.PLATE, FITTING	1				
6	688-83591-00	THERMO UNIT	1				
7	6Y5-83504-01	HOUR METER ASSY	1				
8	688-83664-00	.DAMPER	1				
9	6Y5-83577-00	.PLATE, FITTING	1				
10	6Y5-83536-00	.SOCKET, METER	1				
11	6Y5-83518-00	.BULB (12V-1.7W T6.5)	1				
12	95303-04600	.NUT	2				
13	92990-04100	.WASHER, SPRING	2				
14	6Y7-83504-00	HOUR METER ASSY	1				UR
	6Y7-83504-10	HOUR METER ASSY	1				UR
15	6Y5-8355X-H0	.BRACKET, METER 1	1				
16	92990-04100	.WASHER, SPRING	2				
17	95380-04600	.NUT	2				

VOLTAGE METER

Description	Part No.	Applicable model
DC 12 volts power supply Black panel	6Y7-83503-00	All electrical start models
DC 12 volts power supply White panel	6Y7-83503-10	

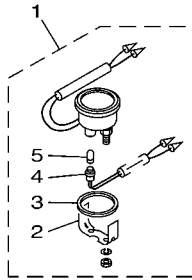

FUEL METER

Description	Part No.	Applicable model
For Yamaha sensor (5 – 105 Ω) Black panel	6Y7-85750-00	All electrical start models
For ABYC sensor (30 – 240 Ω) Black panel	6Y7-85750-10	
For Yamaha sensor (5 – 105 Ω) White panel	6Y7-85750-20	
For ABYC sensor (30 – 240 Ω) White panel	6Y7-85750-30	

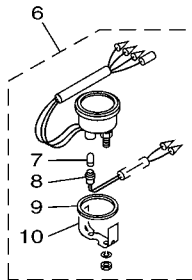

601M10M-J080

FIG. 8 METER 8

REF. NO.	PART NO.	DESCRIPTION	601M				REMARKS
1	6Y7-83503-00	VOLTMETER ASSY	1				UR
	6Y7-83503-10	VOLTMETER ASSY	1				UR
2	6Y5-83544-00	.PLATE, FITTING	1				
3	688-83664-00	.DAMPER	1				
4	6Y5-83536-00	.SOCKET, METER	1				
5	6Y5-83518-00	.BULB (12V-1.7W T6.5)	1				
6	6Y7-85750-00	FUEL METER ASSY	1				UR
	6Y7-85750-10	FUEL METER ASSY	1				UR
	6Y7-85750-20	FUEL METER ASSY	1				UR
	6Y7-85750-30	FUEL METER ASSY	1				UR
7	6Y5-83518-00	.BULB (12V-1.7W T6.5)	1				
8	6Y5-83536-00	.SOCKET, METER	1				
9	688-83664-00	.DAMPER	1				
10	6Y5-83544-00	.PLATE, FITTING	1				

REMOTE-OIL TANK HARNESS ACCESSORY LEAD

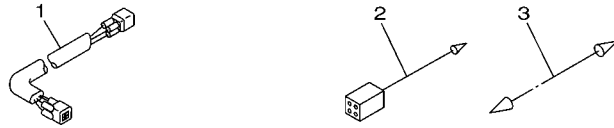

For V4, V6 oil injection model

METER HARNESS (For analog meter)

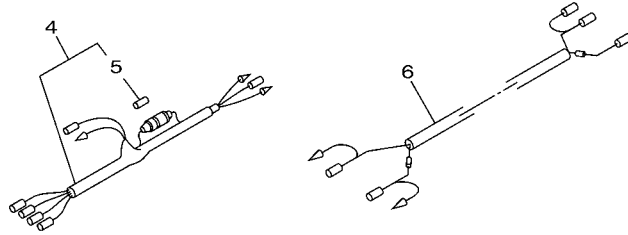

For pre-mixed model

METER HARNESS (For digital meter)

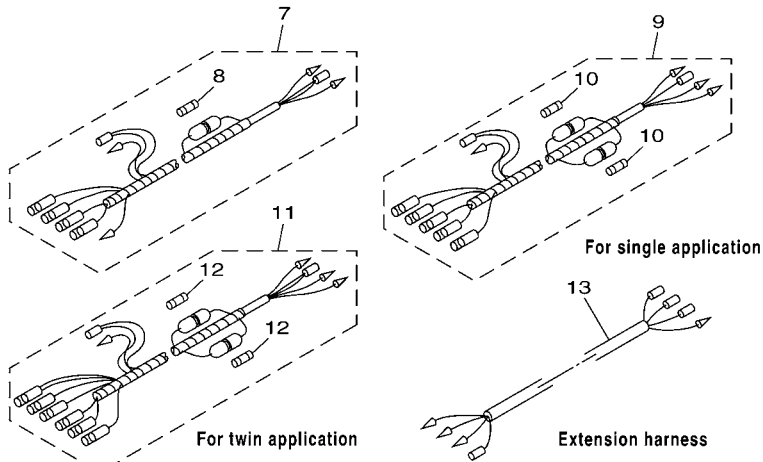

601M10M-J090

FIG. 9 WIRE HARNESS 1

REF. NO.	PART NO.	DESCRIPTION	601M				REMARKS
1	6R3-85721-30	WIRE, LEAD (L=3.0M)	1				UR (4P)
	6R3-85721-50	WIRE, LEAD (L=5.0M)	1				UR (4P)
	6R3-85721-80	WIRE, LEAD (L=8.0M)	1				UR (4P)
2	6Y5-82149-00	WIRE, LEAD (BLUE) (L300)	1				UR
	6Y5-82117-00	WIRE, LEAD (BLACK) (L300)	1				UR
3	703-82531-00	WIRE, LEAD (L=70)	1				L/H MODEL
4	6Y5-83553-00	WIRE, LEAD (L=2.5M)	1				
5	1E6-82151-00	.FUSE (10A)	1				
6	6Y5-83553-10	WIRE, LEAD (L=5.0M)	1				
7	6Y5-83553-20	WIRE, LEAD (L=2.5M)	1				L/H MODEL
8	1E6-82151-00	.FUSE (10A)	1				
9	6Y5-83553-M0	WIRE, LEAD (L=2.5M)	1				
10	1E6-82151-00	.FUSE (10A)	2				
11	6Y5-83553-N0	WIRE, LEAD (L=2.5M)	1				
12	1E6-82151-00	.FUSE (10A)	2				
13	6Y5-8356N-00	WIRE, LEAD (L=1.5M)	1				

LAMP SWITCH

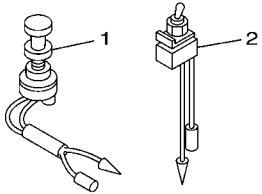

TRIM METER LEAD

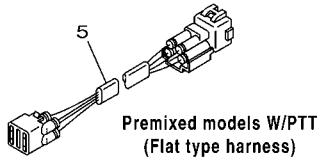

TRIM AND OIL LEAD

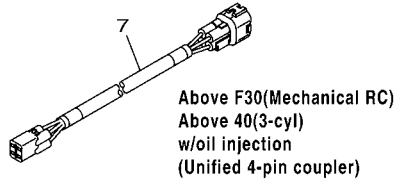

LIGHTING COIL EXTENSION HARNESS

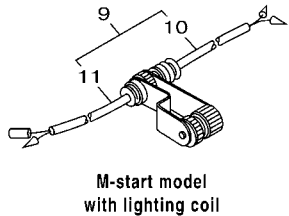

601M10M-K100

COMBINATION TRIM AND OIL LEAD

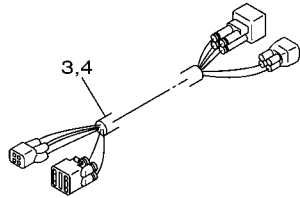

PT/T SWITCH LEAD EXTENSION

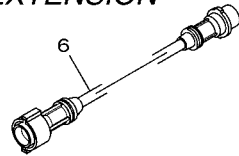

FUEL MANAGEMENT GAUGE HARNESS

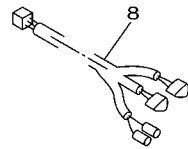

RECTIFIER KIT

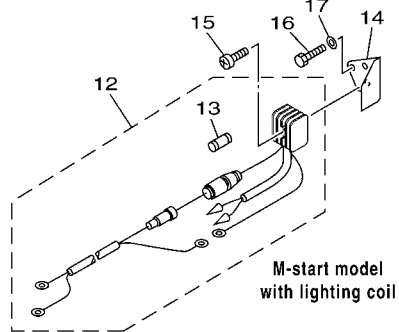

M-start model with lighting coil

FIG. 10 WIRE HARNESS 2

REF. NO.	PART NO.	DESCRIPTION	601M				REMARKS
1	688-82520-00	LIGHT SWITCH ASSY	1				
2	688-82526-00	SWITCH, LAMP	1				
3	64D-82553-50	EXTENSION, WIRE LEAD (L=5.0M)	1				UR FOR (L)250G
	64D-82553-70	EXTENSION, WIRE LEAD (L=7.0M)	1				UR FOR (L)250G
	64D-82553-80	EXTENSION, WIRE LEAD (L=8.0M)	1				UR FOR (L)250G
	64D-82553-90	EXTENSION, WIRE LEAD (L=9.5M)	1				UR FOR (L)250G
4	68F-82553-50	EXTENSION, WIRE LEAD (L=5.0M)	1				UR FOR (L)250G
	68F-82553-70	EXTENSION, WIRE LEAD (L=7.0M)	1				UR FOR (L)250G
	68F-82553-80	EXTENSION, WIRE LEAD (L=8.0M)	1				UR FOR (L)250G
	68F-82553-90	EXTENSION, WIRE LEAD (L=9.5M)	1				UR FOR (L)250G
	68F-82553-A0	EXTENSION, WIRE LEAD (L=10.5M)	1				UR FOR (L)250G
5	6R3-82553-30	EXTENSION, WIRE LEAD (L=3.0M)	1				UR (4P)
	6R3-82553-50	EXTENSION, WIRE LEAD (L=5.0M)	1				UR (4P)
	6R3-82553-70	EXTENSION, WIRE LEAD (L=7.0M)	1				UR (4P)
	6R3-82553-80	EXTENSION, WIRE LEAD (L=8.0M)	1				UR (4P)
	6R3-82553-90	EXTENSION, WIRE LEAD (L=9.0M)	1				UR (4P)
6	688-82586-11	EXTENSION, WIRE HARNESS (2.0M)	1				L:2M(7P)
7	6Y5-83653-00	WIRE, LEAD (L=5.0M)	1				UR 4P,5M
	6Y5-83653-10	WIRE, LEAD (L=6.0M)	1				UR 4P,6M
	6Y5-83653-20	WIRE, LEAD (L=7.0M)	1				UR 4P,7M
	6Y5-83653-30	WIRE, LEAD (L=8.0M)	1				UR 4P,8M
	6Y5-83653-40	WIRE, LEAD (L=9.0M)	1				UR 4P,9M
	6Y5-83653-50	WIRE, LEAD (L=10.5M)	1				UR 4P,10.5M
8	6Y5-83553-F1	WIRE, LEAD (L=8.0M)	1				
9	682-84380-00	CONCENT 2P	1				
10	682-84381-00	.2P CONCENT	1				
11	682-84382-00	.2P CONCENT	1				

LAMP SWITCH

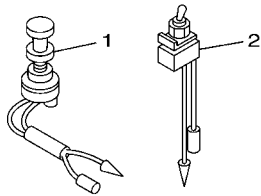

COMBINATION TRIM AND OIL LEAD

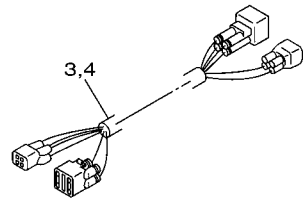

TRIM METER LEAD

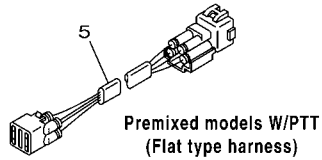

PT/T SWITCH LEAD EXTENSION

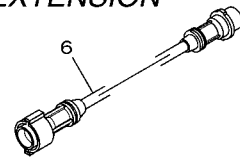

TRIM AND OIL LEAD

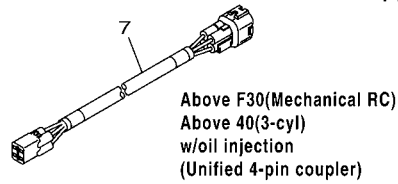

FUEL MANAGEMENT GAUGE HARNESS

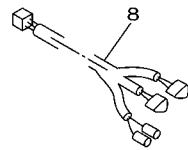

LIGHTING COIL EXTENSION HARNESS

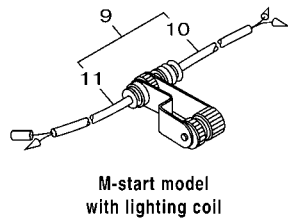

601M10M-K100

RECTIFIER KIT

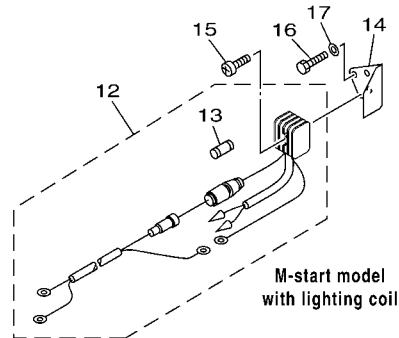
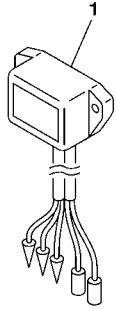

FIG. 10 WIRE HARNESS 2

REF. NO.	PART NO.	DESCRIPTION	601M				REMARKS
12	676-81970-01	RECTIFIER ASSY	1				
13	663-82151-00	.FUSE (12V-20A)	1				
14	677-81975-00	PLATE, RECTIFIER FITTING	1				
15	97880-05025	SCREW, PAN HEAD	1				
16	97013-06010	BOLT	2				
17	92903-06600	WASHER, PLATE	2				

CHARGE WARNING UNIT



All electrical start models with a rectifier/regulator

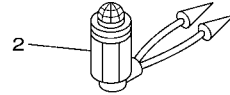

IMMOBILIZER POWER DISTRIBUTION WIRE

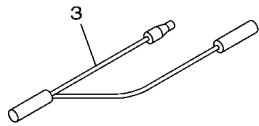

For fuel injection F30-F/FL115A multi-application w/ immobilizer

BATTERY WIRING

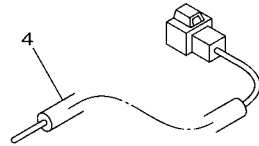

Part No.	Length	Remarks
68F-81949-02	2.7 m 9 ft	For HPDI, F150 and above * Except F225 - F300 off-shore (V6-4.2L)
69J-81949-02	3.8 m 13 ft	
6CE-81949-00	3.8 m 13 ft	For F225, F250, F300 off-shore (V6-4.2L) special

601M10M-K110

FIG. 11 ELECTRICAL

REF. NO.	PART NO.	DESCRIPTION	601M				REMARKS
1	697-81901-60	CHARGE WARNING UNIT ASSY	1				
2	663-84301-01	PILOT LIGHT ASSY 1	1				12V
3	6H5-81315-00	LEAD WIRE ASSY	1				
4	68F-81949-02	WIRE, LEAD (ISOLATOR, 2.7M)	1				UR
	69J-81949-02	WIRE, LEAD (ISOLATOR, 3.8M)	1				UR
	6CE-81949-00	WIRE, LEAD (ISOLATOR CABLE)	1				UR

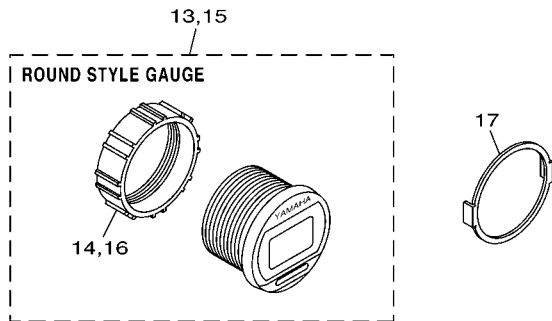
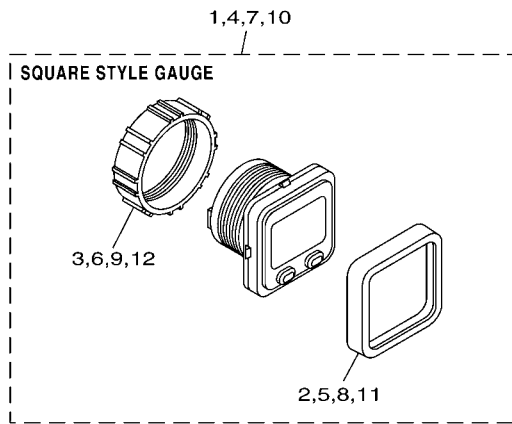
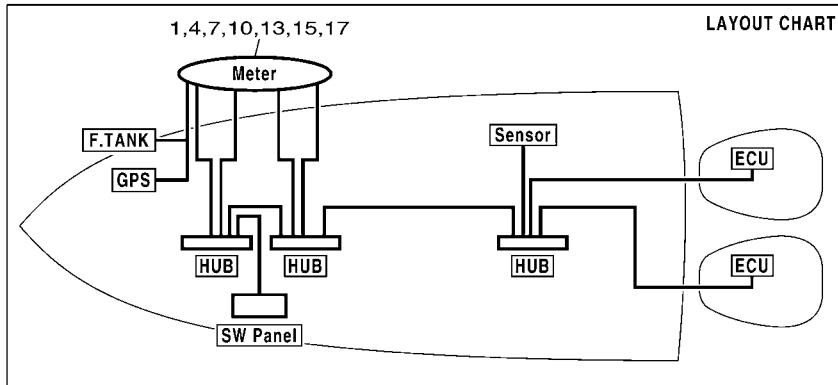

6011100-G880

FIG. 12 DIGITAL NETWORK GAUGE 1

REF. NO.	PART NO.	DESCRIPTION	601M				REMARKS
1	6Y8-8350T-01	TACHOMETER, SQ	1				
2	6Y8-83363-00	.BEZEL, SQUARE	1				
3	6Y8-84383-00	.NUT, RING	1				
4	6Y8-8350S-01	SPEEDOMETER, SQ	1				
5	6Y8-83363-00	.BEZEL, SQUARE	1				
6	6Y8-84383-00	.NUT, RING	1				
7	6Y8-8350F-01	FL MGT METER, SQ	1				FUEL MANAGEMENT
8	6Y8-83363-00	.BEZEL, SQUARE	1				
9	6Y8-84383-00	.NUT, RING	1				
10	6Y8-83500-01	S&FM METER, SQ	1				SPEED & FUEL
11	6Y8-83363-00	.BEZEL, SQUARE	1				
12	6Y8-84383-00	.NUT, RING	1				
13	6Y8-8350T-11	TACHOMETER, RD	1				
14	6Y8-84383-00	.NUT, RING	1				
15	6Y8-83500-11	S&FM METER, RD	1				SPEED & FUEL
16	6Y8-84383-00	.NUT, RING	1				
17	6Y8-83514-00	PLATE, FITTING	1				UN

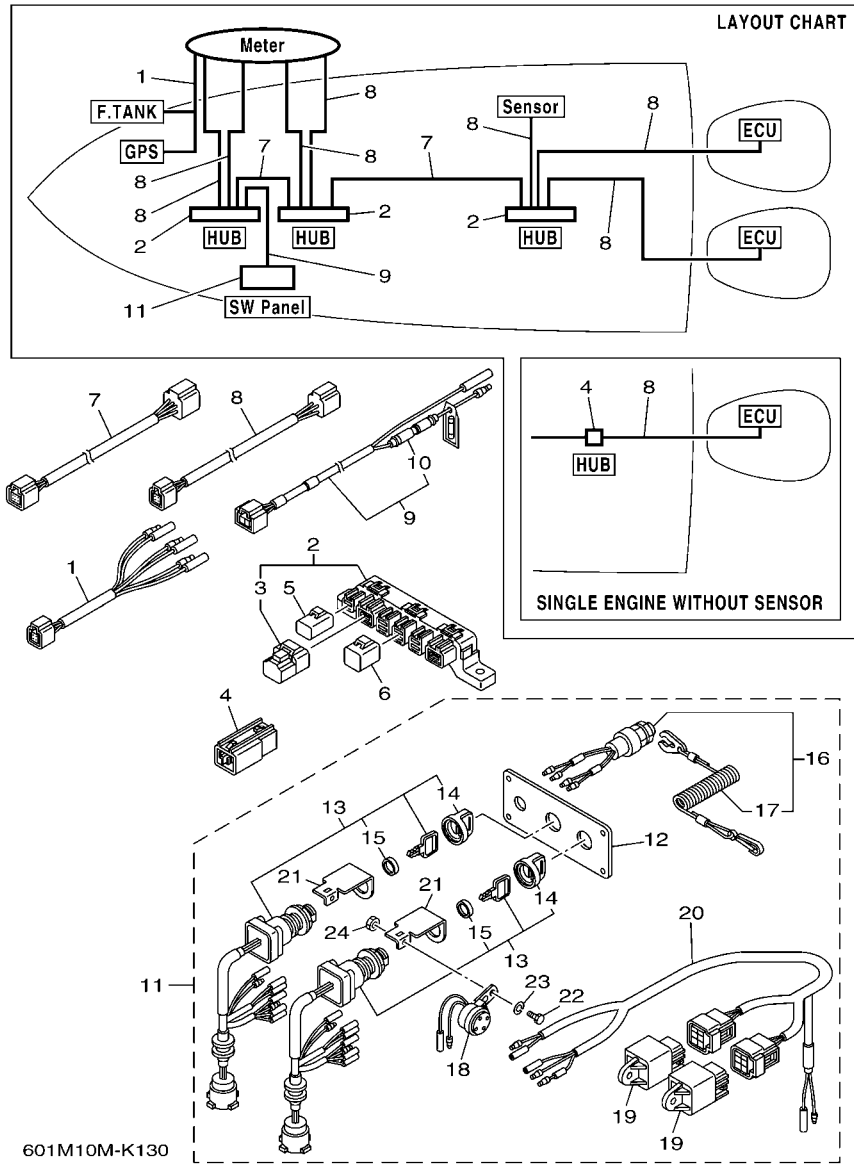

FIG. 13 DIGITAL NETWORK GAUGE 2

REF. NO.	PART NO.	DESCRIPTION	601M				REMARKS
1	6Y8-8356N-01	LEAD, FUEL TANK & GPS SENDER	1				
2	6Y8-81920-01	MULTI HUB ASSY	1				UN
3	6Y8-85371-01	.END OF LINE RESISTER	1				
4	6Y8-81920-11	IN-LINE HUB ASSY	1				
5	6Y8-82582-01	CAP 1 (2PIN)	1				UN
6	6Y8-82582-11	CAP 1 (4PIN)	1				UN
7	6Y8-82553-01	1FT MAIN BUS	1				UR
	6Y8-82553-11	15FT MAIN BUS	1				UR
	6Y8-82553-21	20FT MAIN BUS	1				UR
	6Y8-82553-31	25FT MAIN BUS	1				UR
	6Y8-82553-41	30FT MAIN BUS	1				UR
	6Y8-82553-50	10FT MAIN BUS	1				UR
8	6Y8-82521-01	1FT PIGTAIL BUS	1				UR
	6Y8-82521-11	2FT PIGTAIL BUS	1				UR
	6Y8-82521-21	3FT PIGTAIL BUS	1				UR
	6Y8-82521-31	6FT PIGTAIL BUS	1				UR
	6Y8-82521-41	9FT PIGTAIL BUS	1				UR
	6Y8-82521-51	12FT PIGTAIL BUS	1				UR
9	6Y8-83553-01	8FT POWER WIRE	1				
10	6G1-82151-00	.FUSE (10A)	1				
11	6Y8-82570-02	PANEL SW., TWIN	1				
12	6Y8-82571-01	.PLATE, PANEL SWITCH	1				
13	6Y8-82510-02	.MAIN SWITCH ASSY	2				
14	676-82577-00	..CAP, KEY	1				
15	703-82532-00	..CAP	1				
16	6K1-82575-00	.ENGINE STOP SWITCH ASSY	1				
17	682-82556-00	..LANYARD, STOP SWITCH	1				

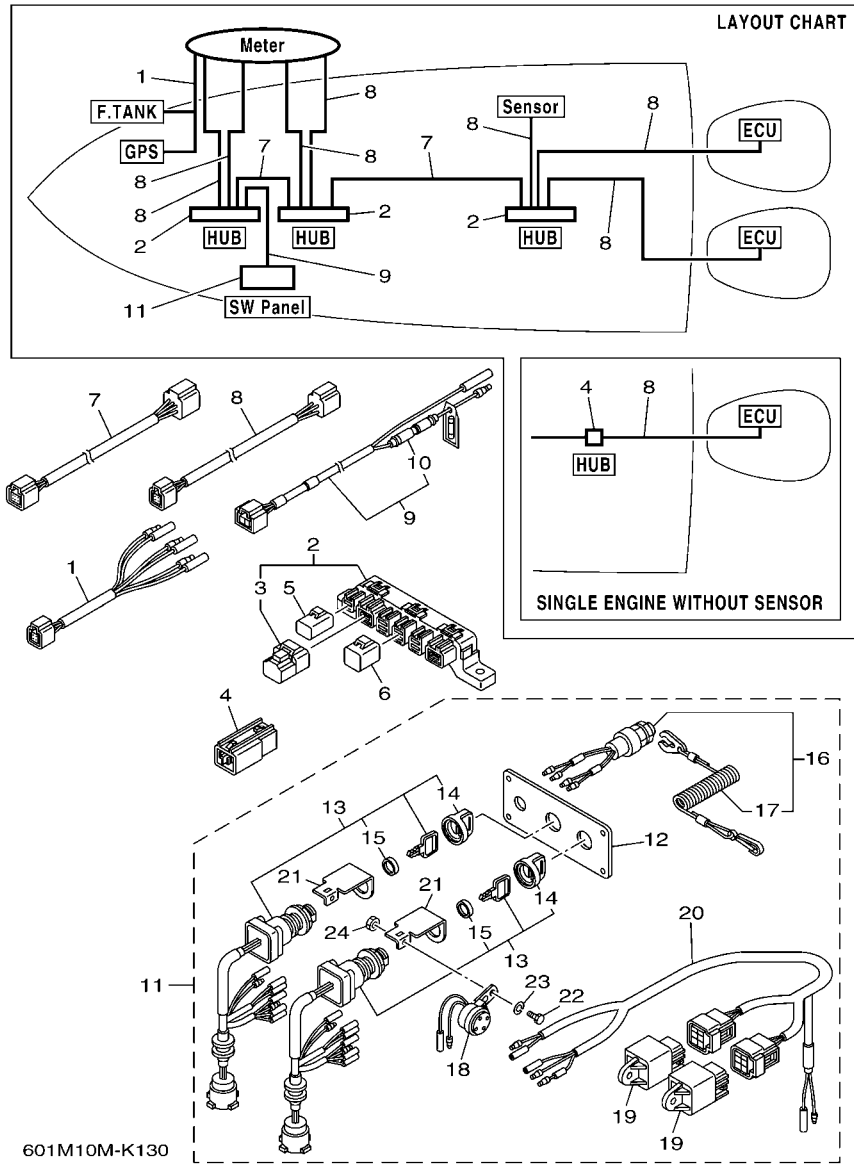
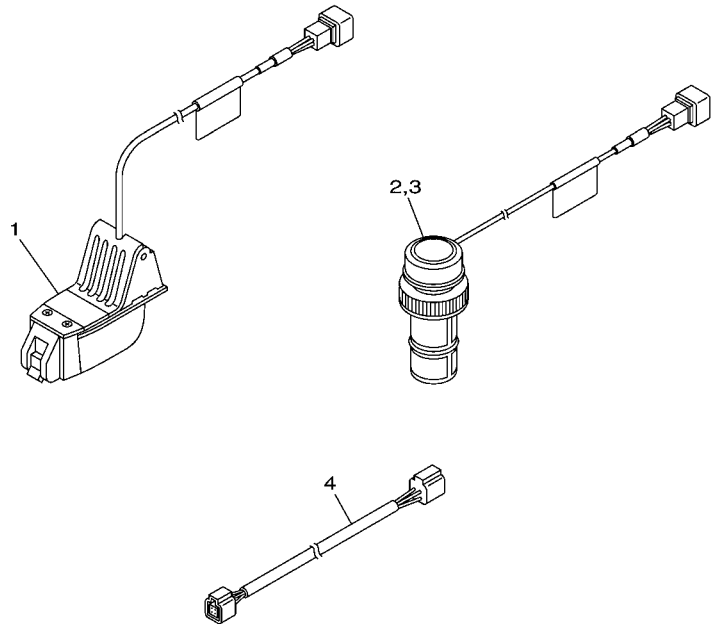
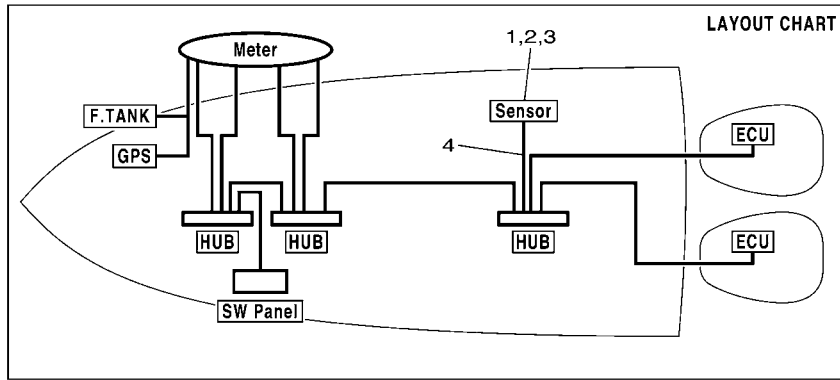

FIG. 13 DIGITAL NETWORK GAUGE 2

REF. NO.	PART NO.	DESCRIPTION	601M				REMARKS
18	6R5-83383-00	.BUZZER	2				
19	68V-81950-00	.RELAY ASSY	2				
20	6Y8-82507-00	.LEAD, IGNITION SWITCH RELAY	1				
21	64D-82581-00	.STAY, CORD CLAMP	2				
22	97303-05012	.BOLT	2				
23	92903-05100	.WASHER, SPRING	2				
24	95303-05700	.NUT	2				



6Y82110-E030

FIG. 14 DIGITAL NETWORK GAUGE 3

REF. NO.	PART NO.	DESCRIPTION	601M				REMARKS
1	6Y8-83688-01	TRANSOM MOUNT TRIDUCER	1				
2	6Y8-83688-11	PLASTIC THRU-HULL TRIDUCER	1				PLASTIC BODY
3	6Y8-83688-20	BRONZE THRU-HULL TRIDUCER	1				BRONZE BODY
4	6Y8-82521-01	1FT PIGTAIL BUS	1				UR
	6Y8-82521-11	2FT PIGTAIL BUS	1				UR
	6Y8-82521-21	3FT PIGTAIL BUS	1				UR
	6Y8-82521-31	6FT PIGTAIL BUS	1				UR
	6Y8-82521-41	9FT PIGTAIL BUS	1				UR
	6Y8-82521-51	12FT PIGTAIL BUS	1				UR

Cooling water pressure sensor

Part No.	Remarks
60V-8A4L0-12	Fuel injected F30-F115, HPDI

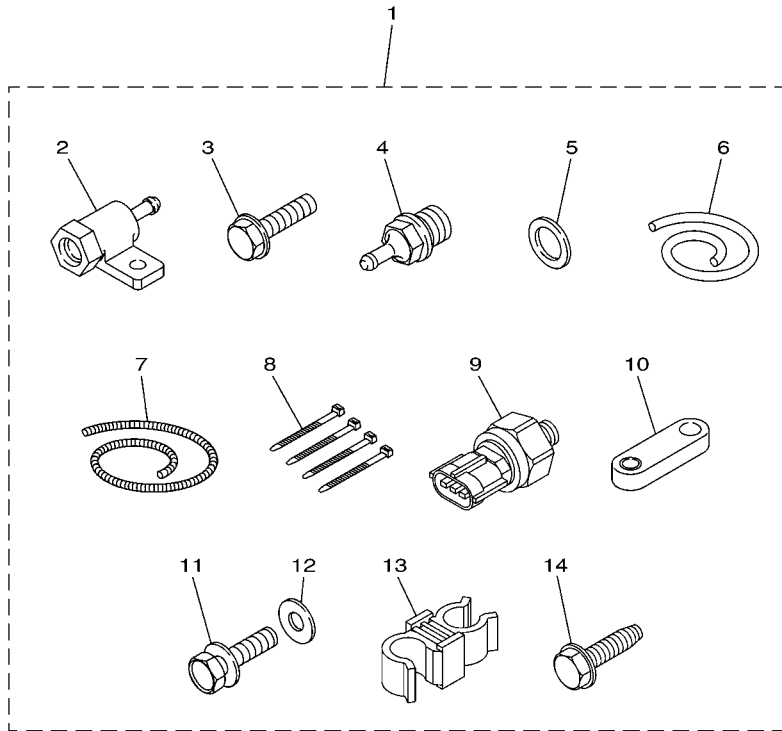

601M10M-J150

FIG. 15 DIGITAL NETWORK GAUGE 4

REF. NO.	PART NO.	DESCRIPTION	601M				REMARKS
1	60V-8A4L0-12	SENSOR, MODULE	1				
2	60V-8366D-00	.ADAPTOR, INPUT	1				
3	95895-06025	.BOLT, FLANGE	1				
4	60V-83667-00	.SENDER, WATER PRESSURE	1				
5	90430-14115	.GASKET	1				
6	90445-07018	.HOSE (L1400)	1				
7	90447-07015	.HOSE, COVER (L: 1300MM)	1				
8	90465-11M10	.CLAMP	4				
9	6AW-8366B-00	.SENSOR, WATER PRESSURE	1				
10	60V-8257V-00	.PLATE, CONNECTOR	1				
11	97095-06016	.BOLT	1				
12	92995-06600	.WASHER	1				
13	90464-09021	.CLAMP	1				
14	90109-06M81	.BOLT	1				

Cooling water pressure sensor

Part No.	Remarks
69J-8A4L0-20	F200-F225 (3.3L)
63P-8A4L0-00	F150, F200-F250 (3.3L-VCT), F225-F300 (4.2L)

* For F350/F300 (V8), standard installed from factory.

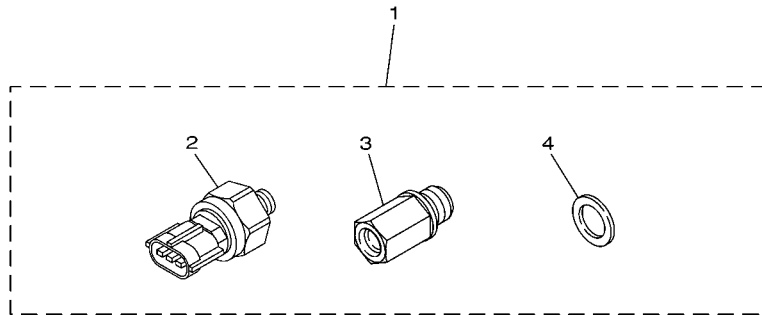

601M10M-K160

FIG. 16 DIGITAL NETWORK GAUGE 5

REF. NO.	PART NO.	DESCRIPTION	601M				REMARKS
1	69J-8A4L0-20	SENSOR, MODULE	1				UR
	63P-8A4L0-00	SENSOR, MODULE	1				UR
2	6AW-8366B-00	.SENSOR, WATER PRESSURE	1				
3	69J-8366C-00	.ADAPTOR, INPUT	1				FOR 69J-8A4L0-20
	63P-8366C-00	.ADAPTOR, INPUT	1				FOR 63P-8A4L0-00
4	90430-14115	.GASKET	1				

Speed sensor

Part No.	Remarks
60V-8A4L1-11	Fuel injected F30-F300 (V6), HPDI

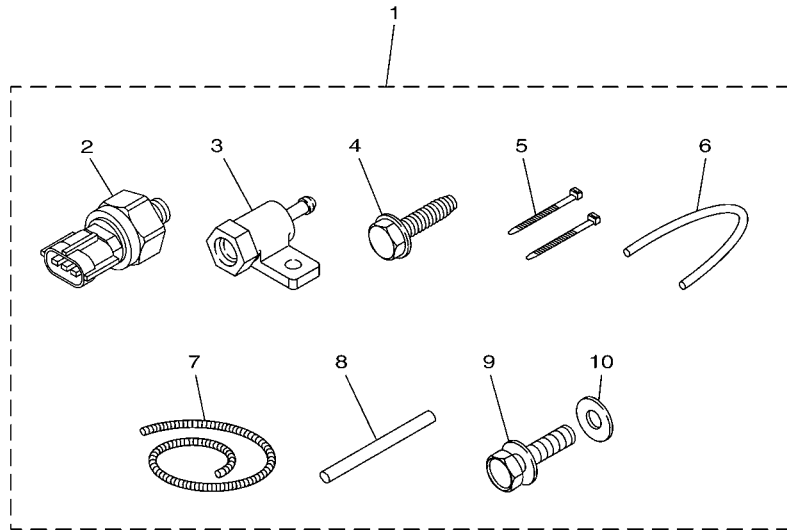

601M10M-K170

FIG. 17 DIGITAL NETWORK GAUGE 6

REF. NO.	PART NO.	DESCRIPTION	601M				REMARKS
1	60V-8A4L1-11	SENSOR, MODULE 1	1				
2	6AW-8366B-00	.SENSOR, WATER PRESSURE	1				
3	60V-8366D-00	.ADAPTOR, INPUT	1				
4	90109-06M81	.BOLT	1				
5	90465-11M10	.CLAMP	2				
6	90445-07017	.HOSE (L: 550MM)	1				
7	90447-07013	.HOSE, COVER (L: 700MM)	1				
8	60V-42629-00	.SEAL	1				
9	97095-06016	.BOLT	1				
10	92995-06600	.WASHER	1				

Speed sensor

Part No.	Remarks
6AW-8A4L1-01	F350/F300 (V8) * Additional transom pitot tube (688-83556-01) and pressure tube(688-83557-00) required.

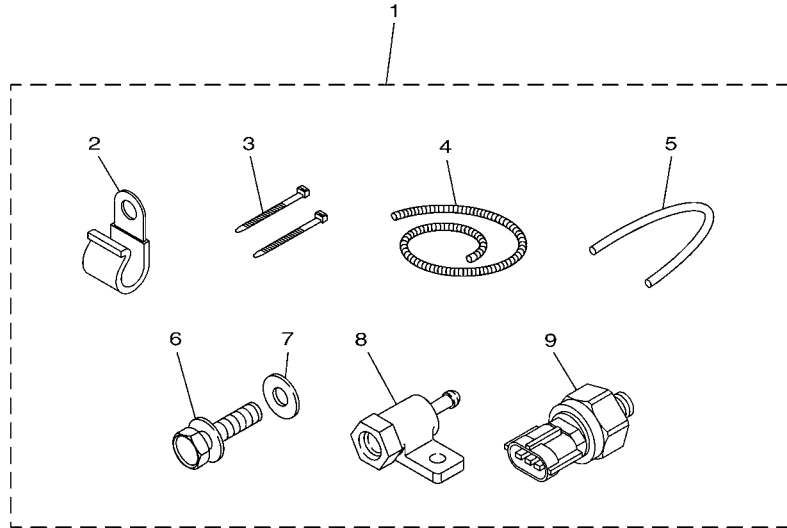

FIG. 18 DIGITAL NETWORK GAUGE 7

REF. NO.	PART NO.	DESCRIPTION	601M				REMARKS
1	6AW-8A4L1-01	SENSOR, MODULE 1	1				
2	90465-06M86	.CLAMP	2				
3	90465-14M66	.CLAMP	2				
4	90447-07015	.HOSE, COVER (L: 1300MM)	1				
5	90445-07018	.HOSE (L1400)	1				
6	97095-06016	.BOLT	1				
7	92995-06600	.WASHER	1				
8	60V-8366D-00	.ADAPTOR, INPUT	1				
9	6AW-8366B-00	.SENSOR, WATER PRESSURE	1				

601M10M-K180

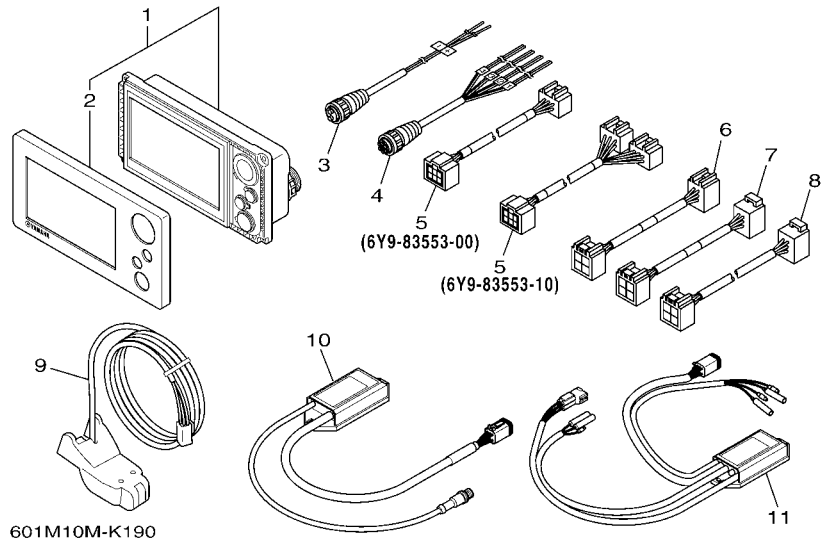
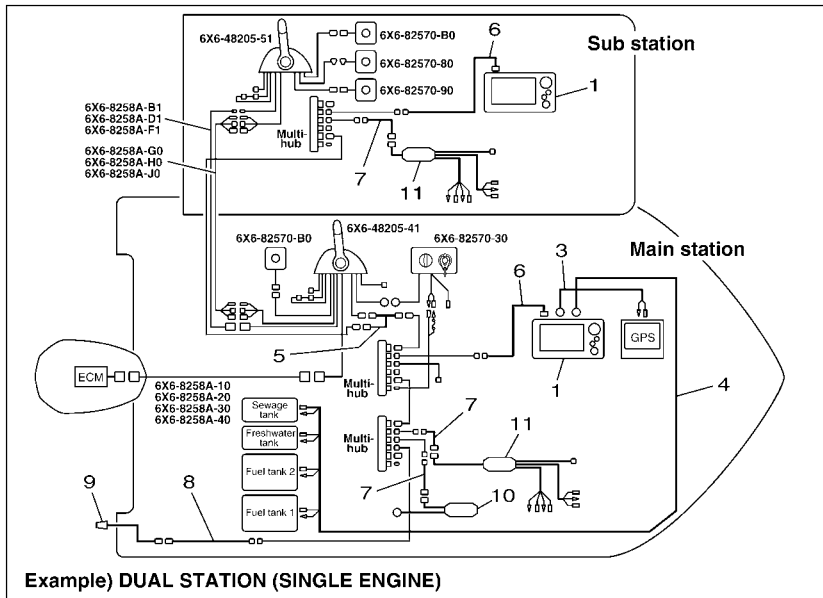

FIG. 19 COMMAND LINK PLUS

REF. NO.	PART NO.	DESCRIPTION	601M		REMARKS
1	6Y9-83710-00	MULTI DISPLAY ASSY	1		UN
2	6Y9-83512-00	.COVER, FRONT	1		
3	6Y9-8356N-00	WIRE, LEAD	1		FOR GPS
4	6Y9-8356N-10	WIRE, LEAD	1		FOR TANKS
5	6Y9-83553-00	WIRE, LEAD	1		UR 1 STATION
6	6Y9-83553-10	WIRE, LEAD	1		UR 2 STATION
7	6Y9-83553-40	WIRE, LEAD	1		UN FOR MULTI DISPLAY
8	6Y9-83553-50	WIRE, LEAD	1		UN FOR INTERFACE UNIT
9	6Y9-83688-00	SENSOR ASSY	1		FOR SENSOR ASSY
10	6Y9-8A2D0-00	INTERFACE UNIT	1		GATEWAY
11	6Y9-8A2D0-10	INTERFACE UNIT	1		UN ANALOGE GAUGE

NUMERICAL INDEX

PART NO.	REF. NO.	PART NO.	REF. NO.	PART NO.	REF. NO.	PART NO.	REF. NO.	PART NO.	REF. NO.	PART NO.	REF. NO.
60V-42629-00	17 - 8	6Y8-82553-50	13 - 7	6Y7-83510-50	4 - 1	6Y5-83544-00	8 - 10	688-83664-00	7 - 4	6Y7-85750-30	8 - 6
6H5-81315-00	11 - 3	64D-82553-70	10 - 3	6Y7-83510-60	4 - 1	6Y5-83553-00	9 - 4		7 - 8	6Y5-85752-02	5 - 8
697-81901-60	11 - 1	68F-82553-70	10 - 4	6Y7-83510-70	4 - 1	6Y9-83553-00	19 - 5		8 - 3		5 - 8
6Y8-81920-01	13 - 2	6R3-82553-70	10 - 5	6Y9-83512-00	19 - 2	6Y8-83553-01	13 - 9		8 - 9		5 - 18
6Y8-81920-11	13 - 4	64D-82553-80	10 - 3	6Y5-83514-00	2 - 5	6Y5-83553-10	9 - 6	688-83665-00	6 - 10	6Y5-87122-S0	3 - 6
6CE-81949-00	11 - 4	68F-82553-80	10 - 4		2 - 12	6Y9-83553-10	19 - 5	688-83666-00	6 - 13		3 - 19
68F-81949-02	11 - 4	6R3-82553-80	10 - 5		2 - 21	6Y5-83553-20	9 - 7	60V-83667-00	15 - 4		5 - 3
69J-81949-02	11 - 4	64D-82553-90	10 - 3		4 - 5	6Y9-83553-40	19 - 6	688-83667-00	6 - 12	6Y9-8A2D0-00	19 - 10
68V-81950-00	13 - 19	68F-82553-90	10 - 4	6Y8-83514-00	12 - 17	6Y9-83553-50	19 - 7	663-83668-00	6 - 11	6Y9-8A2D0-10	19 - 11
676-81970-01	10 - 12	6R3-82553-90	10 - 5	6Y5-83517-00	2 - 2	6Y9-83553-60	19 - 8		6 - 14	63P-8A4L0-00	16 - 1
677-81975-00	10 - 14	68F-82553-A0	10 - 4		2 - 9	6Y5-83553-F1	5 - 7	6AW-8366B-00	15 - 9	60V-8A4L0-12	15 - 1
6Y5-82117-00	5 - 10	682-82556-00	13 - 17		2 - 18		5 - 17		16 - 2	69J-8A4L0-20	16 - 1
	9 - 2	6Y8-82570-02	13 - 11		4 - 2		10 - 8		17 - 2	6AW-8A4L1-01	18 - 1
6Y5-82149-00	9 - 2	6Y8-82571-01	13 - 12	6Y5-83518-00	2 - 14	6Y5-83553-M0	9 - 9		18 - 9	60V-8A4L1-11	17 - 1
1E6-82151-00	9 - 5	6K1-82575-00	13 - 16		2 - 22	6Y5-83553-N0	9 - 11	63P-8366C-00	16 - 3	6Y5-W0088-54	5 - 1
	9 - 8	676-82577-00	13 - 14		6 - 2	688-83557-00	4 - 6	69J-8366C-00	16 - 3	6Y5-W0088-65	5 - 1
	9 - 10	60V-8257V-00	15 - 10		6 - 7	6Y5-83557-00	3 - 20	60V-8366D-00	15 - 2	90109-06M81	15 - 14
	9 - 12	64D-82581-00	13 - 21		7 - 2	6Y5-83557-31	3 - 7		17 - 3		17 - 4
663-82151-00	10 - 13	6Y8-82582-01	13 - 5		7 - 11		3 - 16		18 - 8	90158-06003	5 - 9
6G1-82151-00	13 - 10	6Y8-82582-11	13 - 6		8 - 5	6Y5-8355X-H0	7 - 15	6Y7-83670-00	6 - 1		5 - 9
6Y8-82507-00	13 - 20	688-82586-11	10 - 6		8 - 7	6Y5-8355X-T1	1 - 6	6Y7-83670-20	6 - 1		5 - 19
6Y8-82510-02	13 - 13	6Y8-83363-00	12 - 2	6Y5-83523-00	2 - 4		1 - 11	6Y7-83670-40	6 - 1	90430-14115	15 - 5
688-82520-00	10 - 1		12 - 5		2 - 11		3 - 5	6Y7-83670-50	6 - 1		16 - 4
6Y8-82521-01	13 - 8		12 - 8		2 - 20		3 - 15	6Y9-83688-00	19 - 9	90445-07017	17 - 6
	14 - 4		12 - 11		4 - 4		5 - 4	6Y8-83688-01	14 - 1	90445-07018	15 - 6
6Y8-82521-11	13 - 8	6R5-83383-00	13 - 18	6Y5-83533-T2	3 - 4		5 - 13	6Y8-83688-11	14 - 2		18 - 5
	14 - 4	6Y8-83500-01	12 - 10		3 - 14	6Y5-8356N-00	9 - 13	6Y8-83688-20	14 - 3	90447-07013	17 - 7
6Y8-82521-21	13 - 8	6Y8-83500-11	12 - 15		5 - 16	6Y9-8356N-00	19 - 3	6Y9-83710-00	19 - 1	90447-07015	15 - 7
	14 - 4	6Y5-83500-30	3 - 10	6Y5-83536-00	6 - 3	6Y8-8356N-01	13 - 1	6Y5-83728-00	3 - 8		18 - 4
6Y8-82521-31	13 - 8	6Y5-83500-40	5 - 12		6 - 8	6Y9-8356N-10	19 - 4		3 - 17	90464-09021	15 - 13
	14 - 4	6Y5-83500-F2	5 - 2		7 - 3	6Y5-83570-30	3 - 11	663-84301-01	11 - 2	90465-06M86	18 - 2
6Y8-82521-41	13 - 8	6Y7-83503-00	8 - 1		7 - 10	6Y5-83570-S5	3 - 1	682-84380-00	10 - 9	90465-11M10	3 - 9
	14 - 4	6Y7-83503-10	8 - 1		8 - 4	6Y5-83577-00	7 - 9	682-84381-00	10 - 10		3 - 18
6Y8-82521-51	13 - 8	6Y7-83504-00	7 - 14		8 - 8	6Y7-83590-00	7 - 1	682-84382-00	10 - 11		3 - 21
	14 - 4	6Y5-83504-01	7 - 7	6Y5-83536-10	2 - 3	6Y7-83590-10	7 - 1	6Y8-84383-00	12 - 3		4 - 7
688-82526-00	10 - 2	6Y7-83504-10	7 - 14	6Y5-83536-40	2 - 3	688-83591-00	7 - 6		12 - 6		15 - 8
703-82531-00	5 - 11	6Y5-83509-03	2 - 13		2 - 10	6Y5-83653-00	10 - 7		12 - 9		17 - 5
	9 - 3	6Y8-8350F-01	12 - 7		2 - 19	6Y5-83653-10	10 - 7		12 - 12	90465-14M66	18 - 3
703-82532-00	13 - 15	6Y8-8350S-01	12 - 4		4 - 3	6Y5-83653-20	10 - 7		12 - 14	92903-05100	2 - 16
6Y8-82553-01	13 - 7	6Y8-8350T-01	12 - 1	6Y7-83540-00	2 - 8	6Y5-83653-30	10 - 7		12 - 16		13 - 23
6Y8-82553-11	13 - 7	6Y5-8350T-03	1 - 1	6Y7-83540-10	2 - 8	6Y5-83653-40	10 - 7	6Y8-85371-01	13 - 3	92903-06600	10 - 17
6Y8-82553-21	13 - 7	6Y8-8350T-11	12 - 13	6Y7-83540-20	2 - 1	6Y5-83653-50	10 - 7	6R3-85721-30	9 - 1	92990-04100	1 - 4
6R3-82553-30	10 - 5	6Y5-8350T-90	1 - 7	6Y7-83540-30	2 - 1	6Y7-83660-00	6 - 6	6R3-85721-50	9 - 1		1 - 9
6Y8-82553-31	13 - 7	6Y7-83510-00	4 - 1	6Y7-83540-80	2 - 17	6Y7-83660-10	6 - 6	6R3-85721-80	9 - 1		3 - 2
6Y8-82553-41	13 - 7	6Y7-83510-10	4 - 1	6Y7-83540-90	2 - 17	6Y7-83660-20	6 - 6	6Y5-85721-F0	5 - 20		3 - 12
64D-82553-50	10 - 3	6Y7-83510-20	4 - 1	6Y5-83544-00	6 - 4	6Y7-83660-30	6 - 6	6Y7-85750-00	8 - 6		5 - 5
68F-82553-50	10 - 4	6Y7-83510-30	4 - 1		7 - 5	688-83664-00	6 - 5	6Y7-85750-10	8 - 6		5 - 14
6R3-82553-50	10 - 5	6Y7-83510-40	4 - 1		8 - 2		6 - 9	6Y7-85750-20	8 - 6		7 - 13

NUMERICAL INDEX

PART NO.	REF. NO.	PART NO.	REF. NO.	PART NO.	REF. NO.	PART NO.	REF. NO.	PART NO.	REF. NO.
92990-04100	7 - 16								
92990-05100	2 - 7								
	2 - 24								
92995-06600	15 - 12								
	17 - 10								
	18 - 7								
95303-04600	7 - 12								
95303-05600	2 - 15								
95303-05700	13 - 24								
95380-04600	1 - 5								
	1 - 10								
	3 - 3								
	3 - 13								
	5 - 6								
	5 - 15								
	7 - 17								
95380-05600	2 - 6								
	2 - 23								
95895-06025	15 - 3								
97013-06010	10 - 16								
97095-06016	15 - 11								
	17 - 9								
	18 - 6								
97303-05012	13 - 22								
97880-05025	10 - 15								
9E450-04433	1 - 2								
9E450-04533	1 - 3								
	1 - 8								