



PARTS CATALOGUE

RIGGING-FUEL TANK



1K601-10FE1

()

RIGGING-FUEL TANK
PARTS CATALOGUE
©2011 by Yamaha Motor Co., Ltd.
1st edition, November 2011
All rights reserved.
Any reprinting or unauthorized use
without the written permission of
Yamaha Motor Co., Ltd.
is expressly prohibited.
Printed in Japan.

FOREWORD

This Parts Catalogue is related to the parts for the model(s) on the cover page. When you are ordering replacement parts, please refer to this Parts Catalogue and quote both part numbers and part names correctly.

1. Modifications or additions which have been made after the issue of the Parts Catalogue will be announced in the Parts News.

It is advisable that you make the necessary corrections to the Parts Catalogue according to the Parts News.

2. Abbreviations

The following abbreviations are used in this Parts Catalogue.

“UR” Use specified parts number.

“UN” Use as many as needed.

“AP” Alternate Parts

“LM” Locally Made (Parts need to be ordered locally)

“F#” Frame No. (Applicable machine No.)

“O/S” Over Size

3. The number of components for assembly

- Parts, which are to be supplied in an assembly, are listed with a dot (.) in front of the part name as shown below.
- The numeral appearing to the right of each component part indicates the quantity of parts for each assembly unit.

PART NO.	DESCRIPTION	Q'TY	REMARKS
2F5-83310-60	FRONT FLASHER LIGHT ASSY	2	
115-83311-60	.BULB (6V-18W)	1	

4. Applicable colours of graphics are represented in the “REMARKS” as shown below.

PART NO.	DESCRIPTION	Q'TY	REMARKS
2N4-24110-00-X5	FUEL TANK COMP.	2	MXR
3J1-24240-10	.GRAPHIC, FUEL TANK	1	FOR MXR

5. Note that the illustrations for reference in finding parts numbers are not to be used for assembling. When assembling, please use the applicable service manual.

6. The asterisk (*) before a reference number indicates modified items after the first edition.

CONTENTS

FUEL TANK 1	1
FUEL TANK 2	2
FUEL TANK 3	3
FUEL TANK 4	4
FUEL PIPE	5

INDEX

NUMERICAL INDEX	6
-----------------------	---

FUEL TANK (24L)

Part No.	Capacity L (US gal)	Material	Description
6YJ-24201-00	24 (6.3)	Plastic	Meeting with EPA regulation
6YJ-24201-10	24 (6.3)	Plastic	With fuel gauge, meeting with EPA regulation
6YJ-24201-50	24 (6.3)	Plastic	For CAN. With CSI label, meeting with EPA regulation

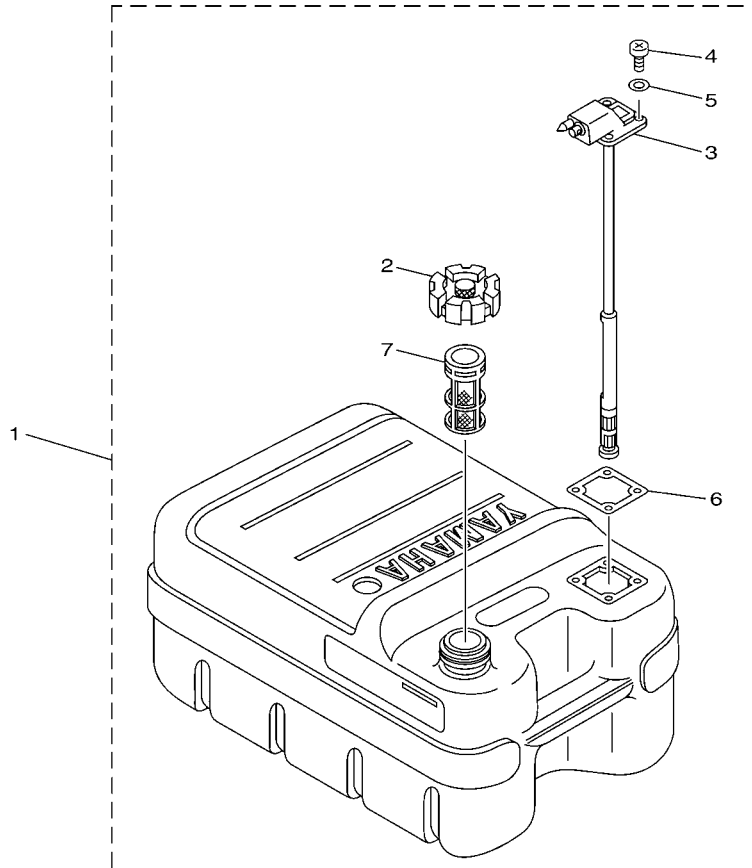

601F10F-J020

FIG. 2 FUEL TANK 2

REF. NO.	PART NO.	DESCRIPTION	601F				REMARKS
1	6YJ-24201-00	FUEL TANK ASSY (24L)	1				UR
	6YJ-24201-10	FUEL TANK ASSY (24L)	1				UR WITH INDICATOR
	6YJ-24201-50	FUEL TANK ASSY (24L)	1				UR WITH INDICATOR
2	6YJ-24610-01	.CAP ASSY	1				
3	6YJ-24260-00	.FUEL METER ASSY	1				UR
	6Y1-24260-12	.FUEL METER ASSY	1				UR WITH INDICATOR
4	90157-05M19	.SCREW, PAN HEAD	4				
5	6Y1-24329-00	.SEAL	4				
6	6Y1-24268-00	.GASKET, FUEL METER	1				
7	6YJ-24167-00	.STRAINER	1				

FUEL TANK (25L)

Part No.	Capacity L (US gal)	Material	Description
6YK-24201-03	25 (6.6)	Plastic	With fuel gauge
6YK-24201-10	25 (6.6)	Plastic	With label and exclusive filler structure banning use of leaded fuel

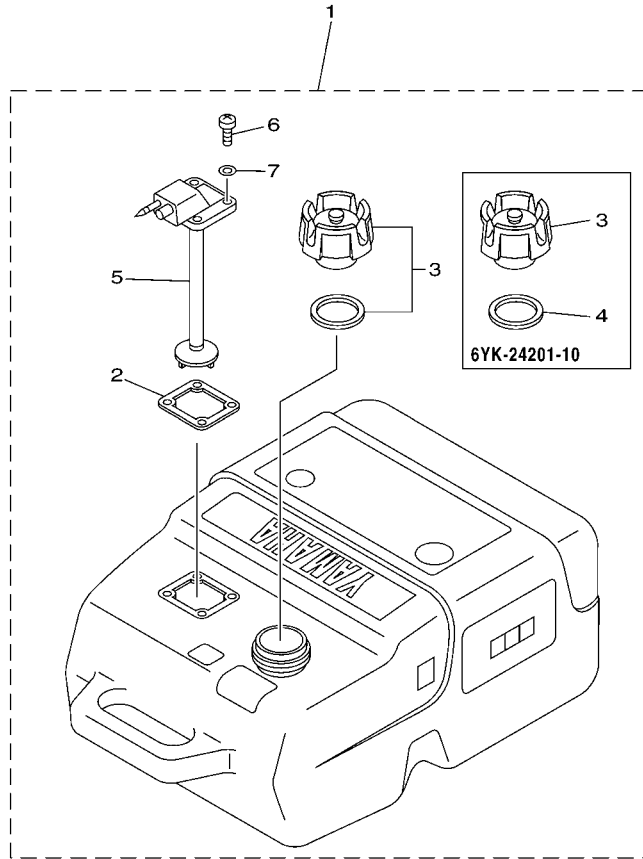

601F10F-J030

FIG. 3 FUEL TANK 3

REF. NO.	PART NO.	DESCRIPTION	601F				REMARKS
1	6YK-24201-03	FUEL TANK ASSY (25L)	1				UR
	6YK-24201-10	FUEL TANK ASSY (25L)	1				UR
2	6YL-24268-01	.GASKET, FUEL METER	1				
3	6YK-24610-01	.CAP ASSY	1				FOR 6YK-24201-03
	6YK-24610-10	.CAP ASSY	1				FOR 6YK-24201-10
4	6YL-24641-00	.GASKET, CAP 1	1				FOR 6YK-24201-10
5	6YK-24260-01	.FUEL METER ASSY	1				
6	90157-05M16	.SCREW, PAN HEAD	4				
7	6YL-24329-00	.SEAL	4				

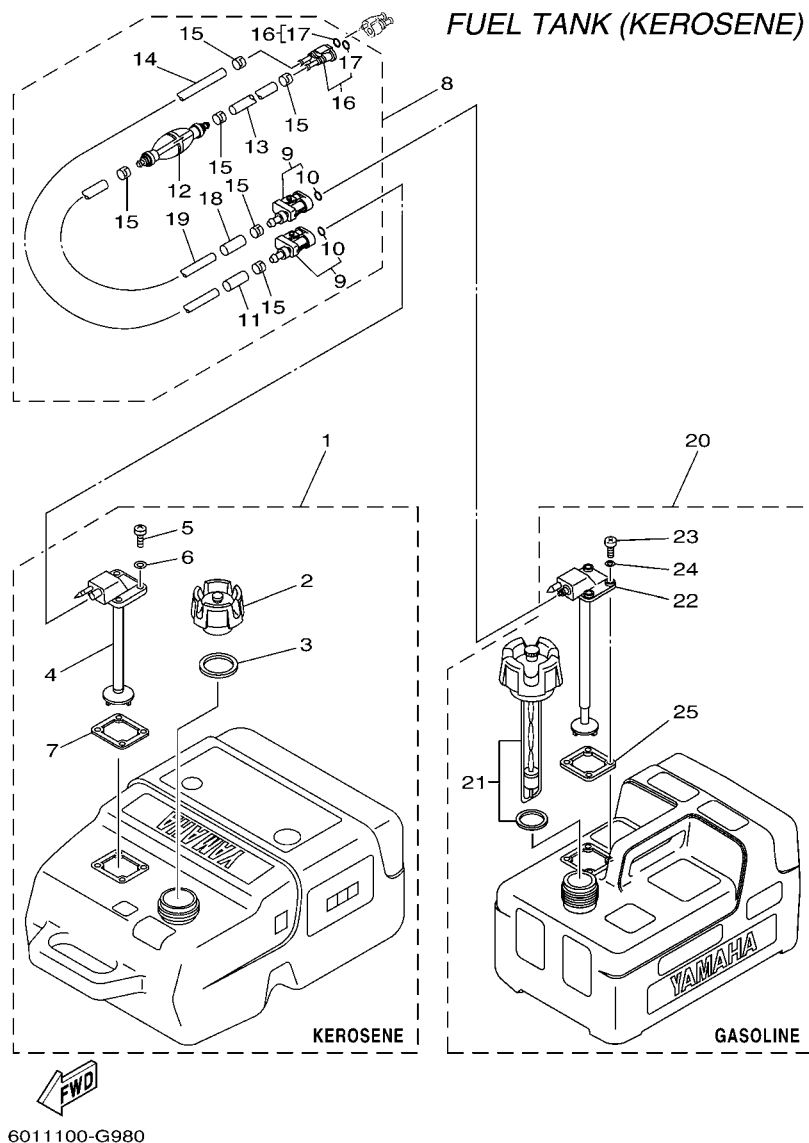

FIG. 4 FUEL TANK 4

REF. NO.	PART NO.	DESCRIPTION	601F				REMARKS
1	6YK-24201-21	FUEL TANK ASSY (25L,KEROSENE)	1				KEROSENE
2	6YK-24610-10	.CAP ASSY	1				WITHOUT INDICATOR
3	6YL-24641-00	.GASKET, CAP 1	1				
4	6YK-24260-01	.FUEL METER ASSY	1				
5	90157-05M16	.SCREW, PAN HEAD	4				
6	6YL-24329-00	.SEAL	4				
7	6YL-24268-01	.GASKET, FUEL METER	1				
8	6YK-24306-04	FUEL PIPE COMP. 1	1				
9	6Y1-24305-06	.FUEL PIPE JOINT COMP. 2	2				
10	93210-08287	..O-RING	1				
11	6Y1-24397-10	.COLLAR (KEROSENE)	1				
12	61J-24360-00	.PRIMER PUMP ASSY	1				
13	90445-11M05	.HOSE (L850)	1				
14	90445-11M81	.HOSE (L3000)	1				
15	650-24351-01	.BAND 1	6				
16	680-24305-01	.FUEL PIPE JOINT COMP. 2	1				
17	93210-08287	..O-RING	2				
18	6Y1-24397-00	.COLLAR (GASOLINE)	1				
19	90445-11M06	.HOSE (L2050)	1				
20	6YL-24201-05	FUEL TANK ASSY (12L)	1				GASOLINE
21	6YL-24610-01	.CAP ASSY	1				
22	6YL-24260-01	.FUEL METER ASSY	1				
23	90157-05M16	.SCREW, PAN HEAD	4				
24	6YL-24329-00	.SEAL	4				
25	6YL-24268-01	.GASKET, FUEL METER	1				

NUMERICAL INDEX

PART NO.	REF. NO.	PART NO.	REF. NO.	PART NO.	REF. NO.	PART NO.	REF. NO.	PART NO.	REF. NO.	PART NO.	REF. NO.
6YJ-24167-00	2 - 7	90157-05M16	3 - 6								
6YJ-24201-00	2 - 1		4 - 5								
6YK-24201-03	3 - 1		4 - 23								
6YL-24201-05	1 - 1	90157-05M19	2 - 4								
	4 - 20	90445-11M05	4 - 13								
6YJ-24201-10	2 - 1		5 - 8								
6YK-24201-10	3 - 1	90445-11M06	4 - 19								
6YK-24201-21	4 - 1		5 - 6								
6YJ-24201-50	2 - 1	90445-11M81	4 - 14								
6YJ-24260-00	2 - 3	93210-08287	4 - 10								
6YK-24260-01	3 - 5		4 - 17								
	4 - 4		5 - 3								
6YL-24260-01	1 - 3		5 - 5								
	4 - 22										
6Y1-24260-12	2 - 3										
6Y1-24268-00	2 - 6										
6YL-24268-01	1 - 6										
	3 - 2										
	4 - 7										
	4 - 25										
680-24305-01	4 - 16										
6G1-24305-05	5 - 2										
6Y1-24305-06	4 - 9										
	5 - 4										
6YK-24306-04	4 - 8										
6Y1-24306-55	5 - 1										
6YK-24306-60	5 - 10										
6Y1-24329-00	2 - 5										
6YL-24329-00	1 - 5										
	3 - 7										
	4 - 6										
	4 - 24										
650-24351-01	4 - 15										
650-24351-51	5 - 7										
61J-24360-00	4 - 12										
6YL-24360-51	5 - 11										
6Y1-24360-52	5 - 9										
6Y1-24397-00	4 - 18										
6Y1-24397-10	4 - 11										
6YJ-24610-01	2 - 2										
6YK-24610-01	3 - 3										
6YL-24610-01	1 - 2										
	4 - 21										
6YK-24610-10	3 - 3										
	4 - 2										
6YL-24641-00	3 - 4										
	4 - 3										
90157-05M16	1 - 4										