

**PARTS
CATALOGUE
CATALOGUE
DE PIÈCES DÉTACHÉES**

F2.5BMH'15 (6EG1)



1P6EG-300F1

()

2016/5/23

NEWS NO.	DATE	COMMENT
PE0-OM-160017	May,16,2016	MOD:FIG.6 VALVE LIST REVISION

F2.5BMH
PARTS CATALOGUE
©2015 by Yamaha Motor Co., Ltd.
1st edition, October 2015
All rights reserved.
Any reprinting or unauthorized use
without the written permission of
Yamaha Motor Co., Ltd.
is expressly prohibited.
Printed in Japan.

F2.5BMH
CATALOGUE DE PIECES DETACHEES
©2015 par Yamaha Motor Co., Ltd.
1^{re} édition, octobre 2015
Tous droits réservés
Toute réimpression ou utilisation
non autorisée sans la permission écrite
de la Yamaha Motor Co., Ltd.
est formellement interdite.
Imprimé au Japon

FOREWORD

This Parts Catalogue is related to the parts for the model(s) on the cover page. When you are ordering replacement parts, please refer to this Parts Catalogue and quote both part numbers and part names correctly.

1. Modifications or additions which have been made after the issue of the Parts Catalogue will be announced in the Parts News.
It is advisable that you make the necessary corrections to the Parts Catalogue according to the Parts News.

2. Abbreviations

The following abbreviations are used in this Parts Catalogue.

“UR” Use specified parts number.

“UN” Use as many as needed.

“AP” Alternate Parts

“LM” Locally Made (Parts need to be ordered locally)

“F#” Frame No. (Applicable machine No.)

“O/S” Over Size

3. The number of components for assembly

- Parts, which are to be supplied in an assembly, are listed with a dot (.) in front of the part name as shown below.
- The numeral appearing to the right of each component part indicates the quantity of parts for each assembly unit.

PART NO.	DESCRIPTION	Q'TY	REMARKS
2F5-83310-60	FRONT FLASHER LIGHT ASSY	2	
115-83311-60	.BULB (6V-18W)	1	

4. Applicable colours of graphics are represented in the “REMARKS” as shown below.

PART NO.	DESCRIPTION	Q'TY	REMARKS
2N4-24110-00-X5	FUEL TANK COMP.	2	MXR
3J1-24240-10	.GRAPHIC, FUEL TANK	1	FOR MXR

5. Note that the illustrations for reference in finding parts numbers are not to be used for assembling. When assembling, please use the applicable service manual.

6. The asterisk (*) before a reference number indicates modified items after the first edition.

7. Applicable Serial No.

Engine Serial No.

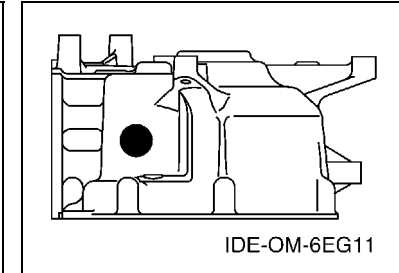
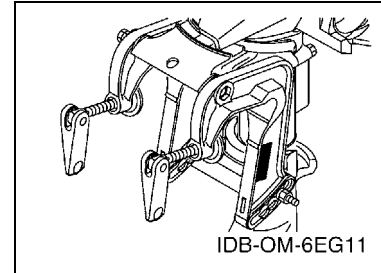

8. Applicable Engine Starting Serial No.

Model	Serial No.	Model	Serial No.
F2.5B	6EG-1000001		

9. Applicable Colour Code

Abbreviation	Colour Name	Colour Code
DBN1	DARK BLUISH GRAY 1	008D

10. Quantity Column Information

Column No.	Name Of Q'ty Column	Applicable Model
1	6EG1	F2.5BMH

AVANT-PROPOS

Ce catalogue de pièces détachées concerne les pièces pour le(s) modèle(s) indiqué(s) sur la page de couverture. Lorsque vous commandez des pièces de rechange, veuillez vous référer à ce catalogue de pièces détachées et indiquer clairement les numéros et les noms des pièces détachées.

1. Les modifications ou ajouts ayant été effectués après la parution du catalogue de pièces détachées seront décrits dans les Bulletins d'information concernant les pièces détachées.

Il est recommandé que vous apportiez les corrections nécessaires au catalogue des pièces détachées en vous référant aux Bulletins d'information.

2. Abréviations

Dans ce catalogue, les abréviations suivantes sont utilisées:

“UR” Utiliser le numéro de pièces spécifié.

“UN” Utiliser autant que nécessaire.

“AP” Pièces de substitution

“LM” Fabrication locale (les pièces doivent être commandées localement.)

“F#” N° de cadre (applicable au N° de série)

“O/S” Surdimensionné

3. Nombre de pièces d'un assemblage

- Les pièces fournies comme composants d'un assemblage sont précédées d'un point (.) de la manière indiquée ci-dessous.
- Le chiffre apparaissant à la droite de chaque composant indique la quantité de pièces pour chaque unité d'assemblage.

N° PIÈCES	DESCRIPTION	QTE	REMARQUES
2F5-83310-60	ENS. CLIGNOTANT AVANT	2	
115-83311-60	.AMPOULE (6V-18W)	1	

4. Les couleurs concernant les graphiques sont indiquées dans la colonne “REMARQUES”, comme indiqué ci-dessous.

N° PIÈCES	DESCRIPTION	QTE	REMARQUES
2N4-24110-00-X5	RESERVOIR A ESSENCE.	2	MXR
3J1-24240-10	.GRAPHIQUE	1	POUR MXR

5. Veuillez noter que les illustrations sont indiquées à titre de référence pour trouver les numéros de pièces, non pour être utilisées lors de l'assemblage. Lors de l'assemblage, veuillez utiliser le manuel d'entretien adéquat.

6. L'astérisque (*) placé devant un numéro de référence indique des éléments qui ont été modifiés après la première édition.

7. N° de série applicable

N° de Série du moteur

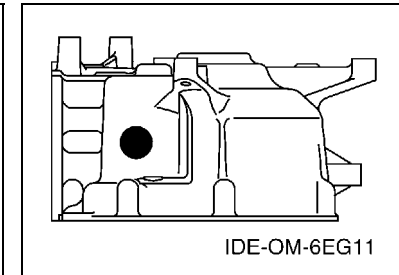
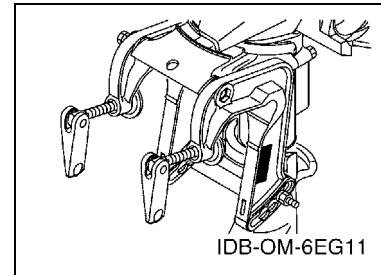

8. N° de série initial du moteur applicable

Modèle	N° de série	Modèle	N° de série
F2.5B	6EG-100001		

9. Code couleur applicable

Abréviation	Nom de la couleur	Code couleur
DBN1	DARK BLUISH GRAY 1	008D

10. Informations relatives à la colonne Quantité

N° de la colonne	Nom de la colonne Qté	Modèle applicable
1	6EG1	F2.5BMH

CONTENTS

SCHEDULED SERVICE PARTS	1
TOP COWLING	2
CYLINDER & CRANKCASE 1	3
CRANKSHAFT & PISTON	4
CYLINDER & CRANKCASE 2	5
VALVE	6
INTAKE	7
CARBURETOR	8
FUEL	9
STARTER	11
GENERATOR	12
BOTTOM COWLING	13
STEERING	14
CONTROL	16
BRACKET	17
UPPER CASING	19
LOWER CASING & DRIVE 1	20
LOWER CASING & DRIVE 2	22
REPAIR KIT 1	23
REPAIR KIT 2	24
REPAIR KIT 3	25

INDEX

NUMERICAL INDEX	26
-----------------------	----

TABLE DES MATIERES

PIECES MAINTENANCE PERIODIQUE	1
CAPOT SUPERIEUR	2
CYLINDRE & CARTER 1	3
VILEBREQUIN & PISTON	4
CYLINDRE & CARTER 2	5
SOUPAPE	6
ADMISSION	7
CARBURATEUR	8
CARBURANT	9
DEMARREUR	11
GENERATRICE	12
CAPOT INFERIEUR	13
DIRECTION	14
COMMANDE	16
SUPPORT	17
FOURREAU	19
BOITIER D'HELICE TRANSMISSION1	20
BOITIER D'HELICE TRANSMISSION2	22
KITS DE REPARATION 1	23
KITS DE REPARATION 2	24
KITS DE REPARATION 3	25
INDEX	
INDEX NUMERIQUE	26

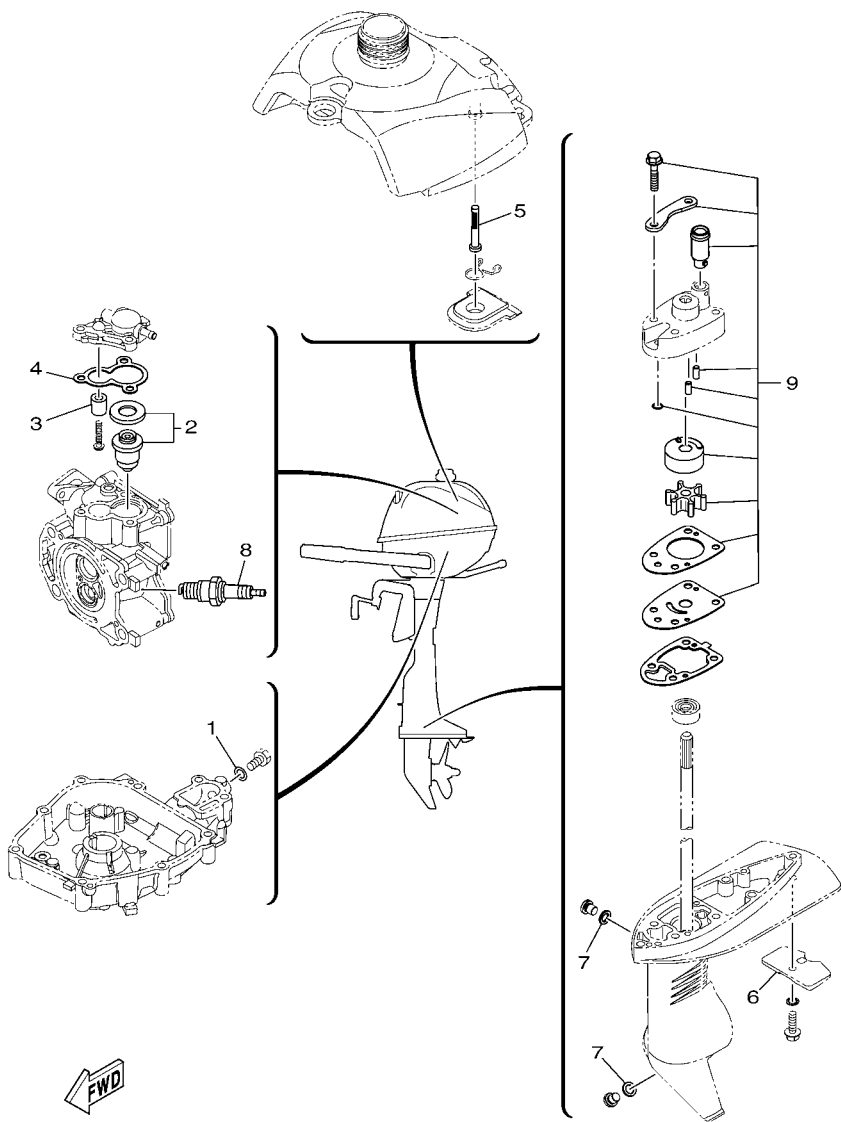

6EG1100-P010

FIG. 1 SCHEDULED SERVICE PARTS PIÈCES MAINTENANCE PERIODIQUE

REF. NO.	PART NO. N° PIÈCES	DESCRIPTION DESCRIPTION	6EG1				REMARKS REMARQUES
1	90430-08143	GASKET JOINT	1				
2	69M-12411-01	THERMOSTAT THERMOSTAT	1				
3	6G8-11325-00	ANODE ANODE	1				
4	67D-12414-A0	GASKET, COVER JOINT, COUVERCLE	1				
5	6L5-24251-00	STRAINER 1 FILTRE 1	1				
6	6L5-45251-03	ANODE ANODE	1				
7	90430-08020	GASKET JOINT	2				
8	94702-00372	PLUG, SPARK (NGK CR6HSB) BOUGIE D, ALLUMAGE	1				
9	6EG-W0078-00	WATER PUMP REPAIR KIT KIT DE REPARATION DE LA POMPE	1				

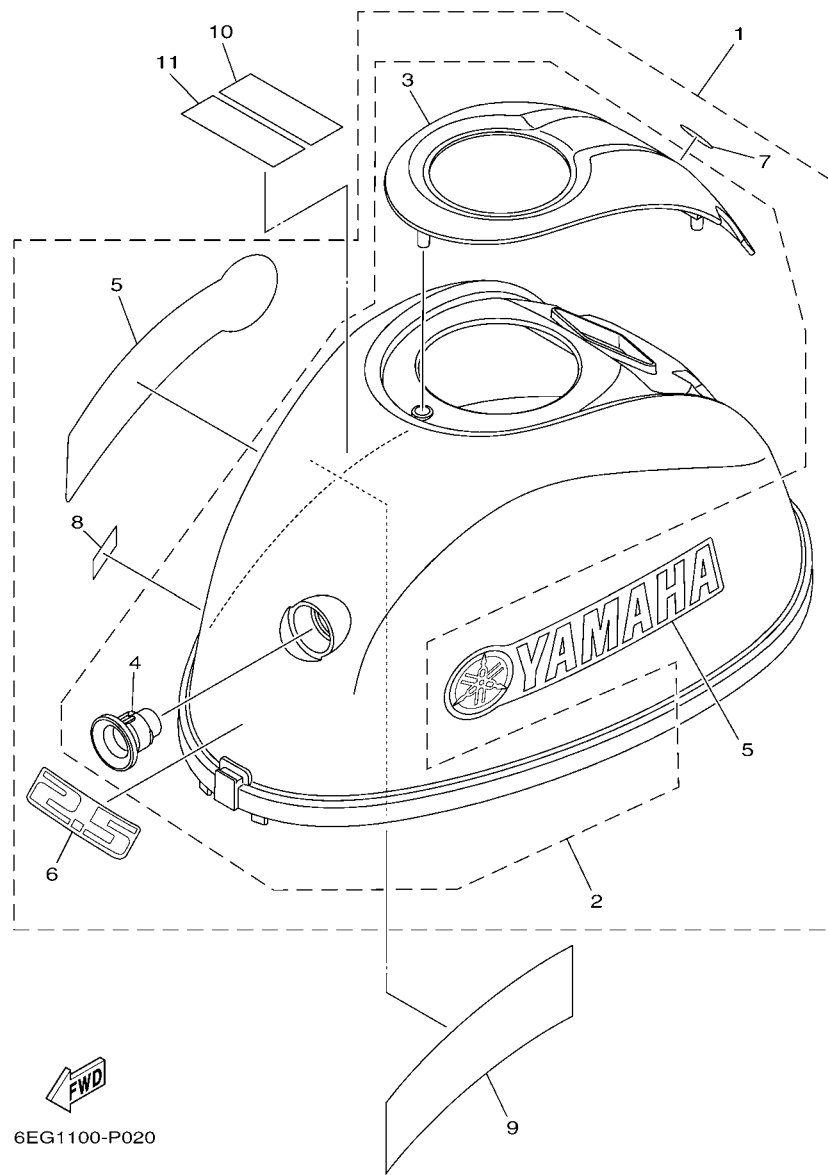

FIG. 2 TOP COWLING

CAPOT SUPERIEUR

REF. NO.	PART NO. N° PIECES	DESCRIPTION DESCRIPTION	6EG1				REMARKS REMARQUES
1	6EG-G2610-00	TOP COWLING ASSY CAPOT (ENS.)	1				
2	6EG-G261A-00	.TOP COWLING W/O GRAPHICS .CAPOT SUPERIEUR SANS GRAPHIQUE	1				
3	6EG-G2613-00	..MOLDING, AIR DUCT ..MANCHON A AIR	1				
4	6EG-E5795-00	..GUIDE, ROPE ..GUIDE DE CABLE	1				
5	6EG-G2675-00	.GRAPHIC, SIDE 1 .EMBLEME	2				
6	6EG-G2677-00	.GRAPHIC, FRONT .ADHESIF, AVANT	1				
7	6EG-G2697-00	.TUNING FORK MARK .MARQUE, YAMAHA	1				
8	6EG-G4191-00	.INDICATOR, SHIFT .ETIQUETTE, EMBRAYAGE	1				
9	6EG-E4427-60	LABEL, INSTRUCTION ETIQUETTE, INSTRUCTION	1				
10	6EE-G2698-40	LABEL, WARNING (FUEL) ETIQUETTE, AVERTISSEMENT	1				
11	6EE-G2698-50	LABEL, WARNING (FUEL) ETIQUETTE, AVERTISSEMENT	1				

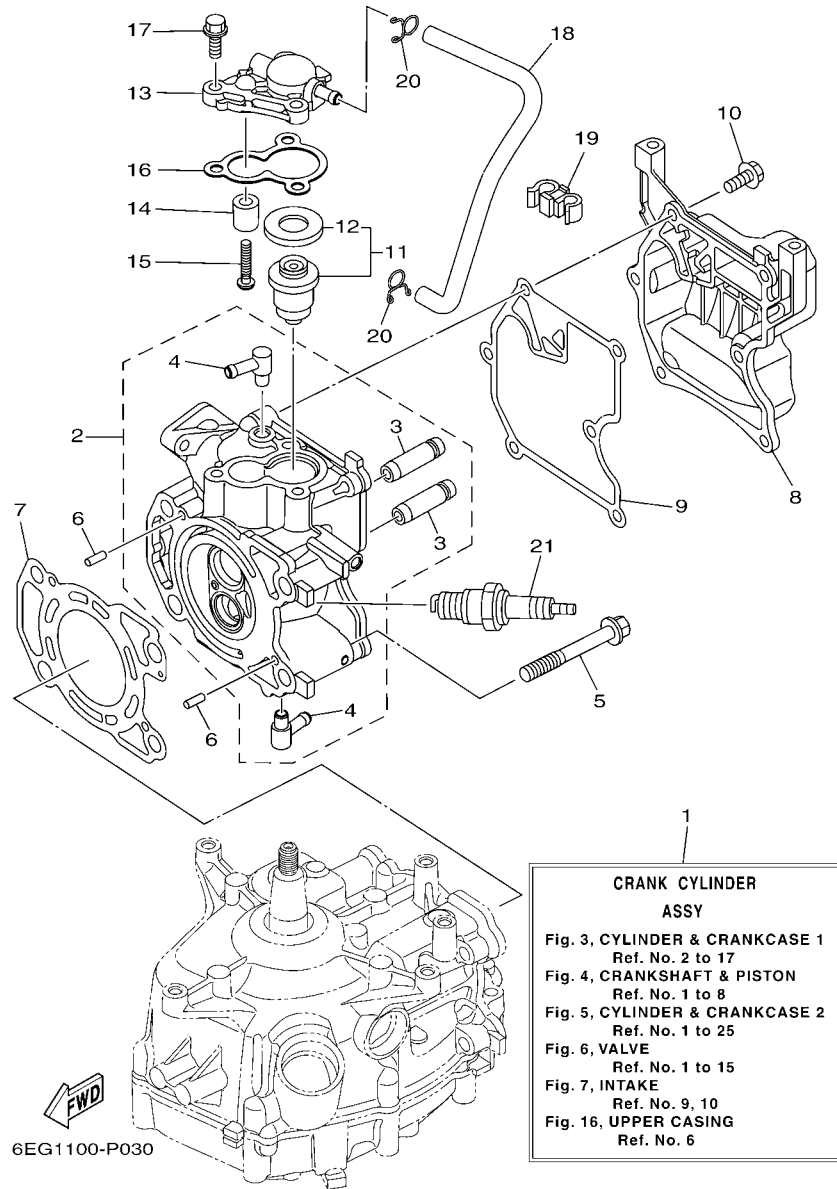
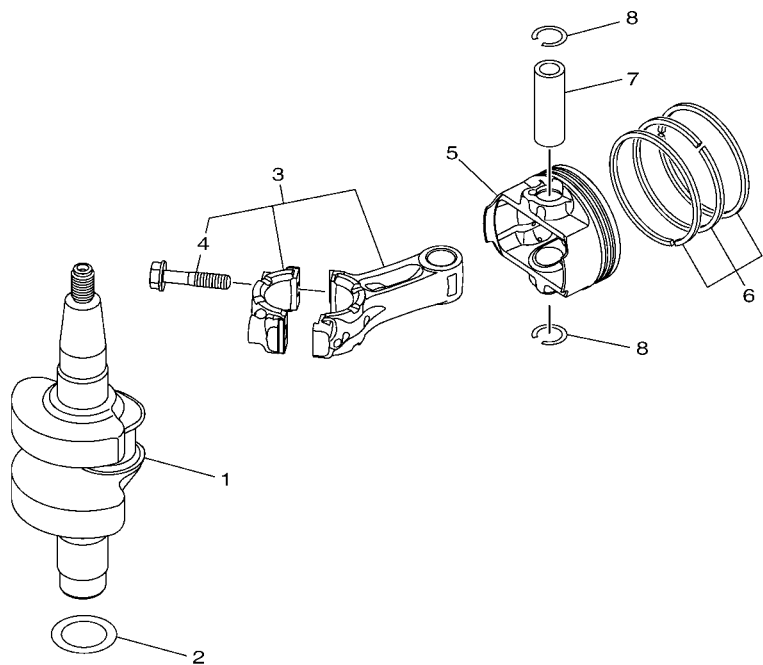

FIG. 3 CYLINDER & CRANKCASE 1 CYLINDRE & CARTER 1

REF. NO.	PART NO. N° PIECES	DESCRIPTION DESCRIPTION	BEG1			REMARKS REMARQUES
1	6EG-WE090-00-1S	CRANK CYLINDER ASSY EMBIELLAGE CYLINDRE (ENS.)	1			
2	6EG-E1111-00-1S	HEAD, CYLINDER 1 CULASSE	1			
3	6EE-E1133-10	.GUIDE, VALVE 1 .GUIDE, SOUPAPE 1	2			
4	676-11372-00	.NIPPLE, HOSE .RACCORD, TUYAU	2			
5	90105-08M36	BOLT, FLANGE BOULON	4			
6	93604-12M07	PIN, DOWEL CLAVETTE	2			
7	6EG-E1181-00	GASKET, CYLINDER HEAD 1 JOINT, DE CULASSE 1	1			
8	6EG-E1191-00	COVER, CYLINDER HEAD 1 COUVERCLE, CULASSE 1	1			
9	6EG-E1193-00	GASKET, HEAD COVER 1 JOINT, COUVERCLE DE CULASSE 1	1			
10	90105-06039	BOLT, FLANGE BOULON	6			
11	69M-12411-01	THERMOSTAT THERMOSTAT	1			
12	688-12412-00	.SEAL, THERMOSTAT .JOINT, THERMOSTAT	1			
13	6EG-E2413-00-1S	COVER, THERMOSTAT COUVERCLE, THERMOSTAT	1			
14	6G8-11325-00	ANODE ANODE	1			
15	97880-05025	SCREW, PAN HEAD VIS. TETE TRONCONIQUE	1			
16	67D-12414-A0	GASKET, COVER JOINT, COUVERCLE	1			
17	90119-06MA2	BOLT, WITH WASHER BOULON, AVEC RONDELLE	3			
18	90445-09808	HOSE (L240) DURITE (L240)	1			
19	90464-09013	CLAMP BRIDE	1			
20	90467-09M09	CLIP JONC	2			
21	94702-00372	PLUG, SPARK (NGK CR6HSB) BOUGIE D,ALLUMAGE	1			

FIG. 4 CRANKSHAFT & PISTON

VILEBREQUIN & PISTON



6EG1100-P040

REF. NO.	PART NO. N° PIECES	DESCRIPTION DESCRIPTION	6EG1				REMARKS REMARQUES
1	6EG-11410-00	CRANKSHAFT VILEBREQUIN COMPLET	1				
2	90201-23008	WASHER, PLATE RONDELLE, PLATE	1				
3	6EG-E1650-00	CONNECTING ROD ASSY BIELLE COMPLETE	1				
4	7DX-E1654-00	.BOLT, CONNECTING ROD .BOULON, BIELLE	2				
5	6EG-E1631-00	PISTON (STD) PISTON (STD)	1				
6	6EG-E1635-00	PISTON (0.25MM O/S) PISTON (0.25MM O/S)	1				AP AP
6	6EG-E1636-00	PISTON (0.50MM O/S) PISTON (0.50MM O/S)	1				AP AP
6	69M-E1603-01	PISTON RING SET (STD) JEU DE SEGMENTS (STD)	1				
6	69M-E1604-01	PISTON RING SET (0.25MM O/S) JEU DE SEGMENTS (0.25MM O/S)	1				AP AP
6	69M-E1605-01	PISTON RING SET (0.50MM O/S) JEU DE SEGMENTS (0.50MM O/S)	1				AP AP
7	6EG-E1633-00	PIN, PISTON AXE, PISTON	1				
8	93450-13811	CIRCLIP CIRCLIP, TYPE S	2				

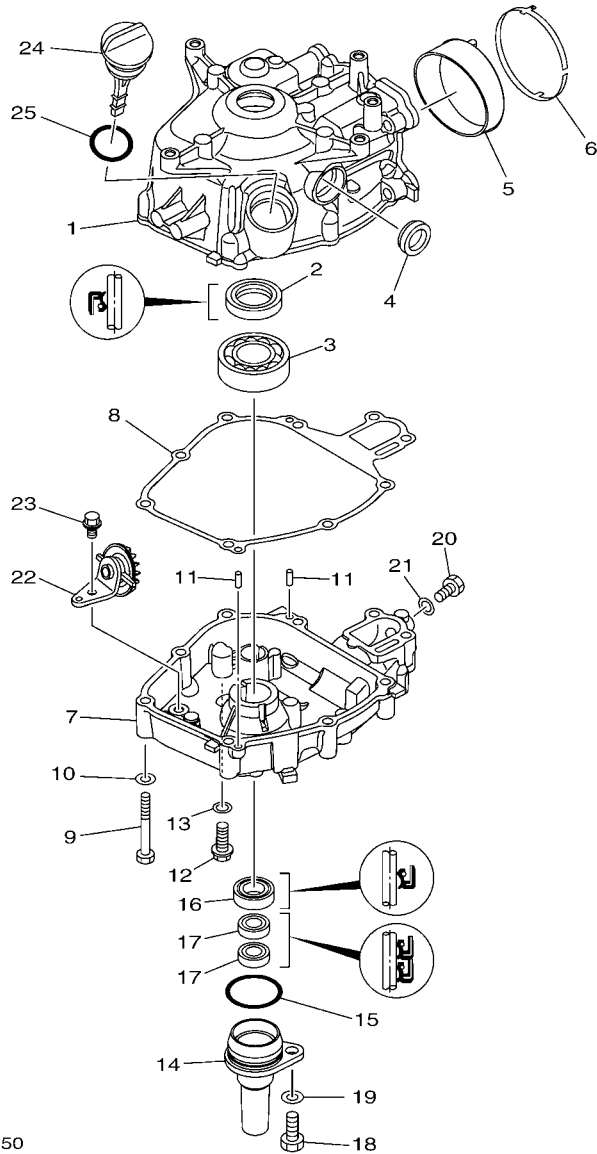

6EG1100-P050

FIG. 5 CYLINDER & CRANKCASE 2 CYLINDRE & CARTER 2

REF. NO.	PART NO. N° PIECES	DESCRIPTION DESCRIPTION	6EG1				REMARKS REMARQUES
1	6EG-E1311-00-1S	CYLINDER 1 CYLINDRE 1	1				
2	93102-20814	OIL SEAL JOINT SPY	1				
3	93306-272Y2	BEARING ROULEMENT	1				
4	3Y6-15361-00	GAUGE, LEVEL JAUGE A HUILE	1				
5	6EG-14664-00	GROMMET, WATER SHUT PASSE-FIL	1				
6	6EG-1246L-00	RING, STOP 1 BAGU, BUTEE 1	1				
7	6EG-E5111-00-1S	CRANKCASE 1 CARTER DE MOTEUR	1				
8	6EG-11351-00	GASKET, CYLINDER JOINT, D'EMBASE	1				
9	97013-06045	BOLT BOULON	9				
10	92903-06600	WASHER, PLATE RONDELLE, PLATE	9				
11	93604-12M07	PIN, DOWEL CLAVETTE	2				
12	90105-08M76	BOLT, FLANGE BOULON	1				
13	90201-08818	WASHER, PLATE RONDELLE, PLATE	1				
14	6EG-E5396-00-CA	HOUSING, OIL SEAL LOGEMENT DE JOINT SPY	1				
15	93210-35803	O-RING JOINT TORIQUE	1				
16	93102-20814	OIL SEAL JOINT SPY	1				
17	93102-09800	OIL SEAL JOINT SPY	2				
18	97095-08020	BOLT BOULON	1				
19	92995-08600	WASHER RONDELLE	1				
20	97095-08014	BOLT BOULON	1				
21	90430-08143	GASKET JOINT	1				
22	6EG-E3102-00	GEAR UNIT ASSY PIGNON	1				
23	95817-06012	BOLT, FLANGE BOULON, A COLLERETTE	1				
24	6EG-E5362-00	PLUG, OIL LEVEL PLOT, NIVEAU D'HUILE	1				
25	93210-24800	O-RING JOINT TORIQUE	1				

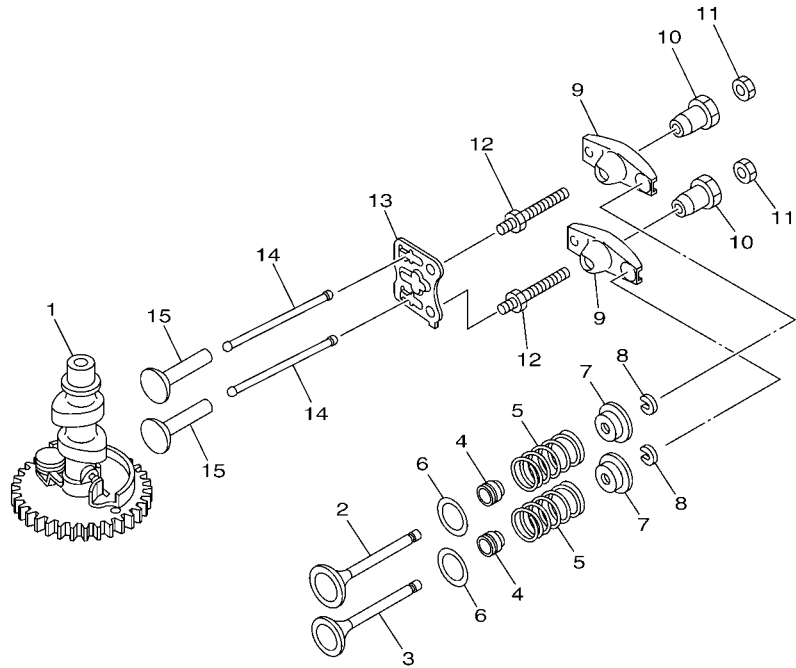

FIG. 6 VALVE

SOUPAPE

REF. NO.	PART NO. N° PIECES	DESCRIPTION DESCRIPTION	6EG1				REMARKS REMARQUES
1	6EG-E2170-00	CAMSHAFT ASSY 1 ENS ARBRE A CAMES 1	1				
2	6EG-12111-10	VALVE, INTAKE SOUPAPE, ADMISSION	1				
3	6EG-E2121-10	VALVE, EXHAUST SOUPAPE, ECHAPPEMENT	1				
4	6EE-E2119-00	SEAL, VALVE STEM JOINT, QUEUE DE SOUPAPE	2				
5	6EG-E2113-00	SPRING, VALVE INNER RESSORT DE SOUPAPE, INTERNE	2				
6	90201-168G9	WASHER, PLATE RONDELLE, PLATE	2				
7	7NJ-12117-00	RETAINER, VALVE SPRING BUTEE DE RESSORT DE SOUPAPE	2				
8	7NJ-12118-00	LOCK, VALVE SPRING RETAINER FRAISE, SOUPAPE	2				
9	67D-12151-00	ARM, VALVE ROCKER CULBUTEUR	2				
10	6EE-E2165-00	PIVOT, ROCKER ARM PIVOT, CULBUTEUR	2				
11	6EE-E2158-00	NUT, LOCK CONTRE-ECROU	2				
12	67D-12157-00	BOLT BOULON	2				
13	6EG-E2155-00	GUIDE, PUSH ROD GUIDE, TIGE-POUSSOIR	1				
14	6EG-E2154-00	ROD, VALVE PUSH TIGE DE LEVE-SOUPAPE	2				
15	6EE-E2153-00	LIFTER, VALVE LEVE-SOUPAPE	2				



6EG1100-P060

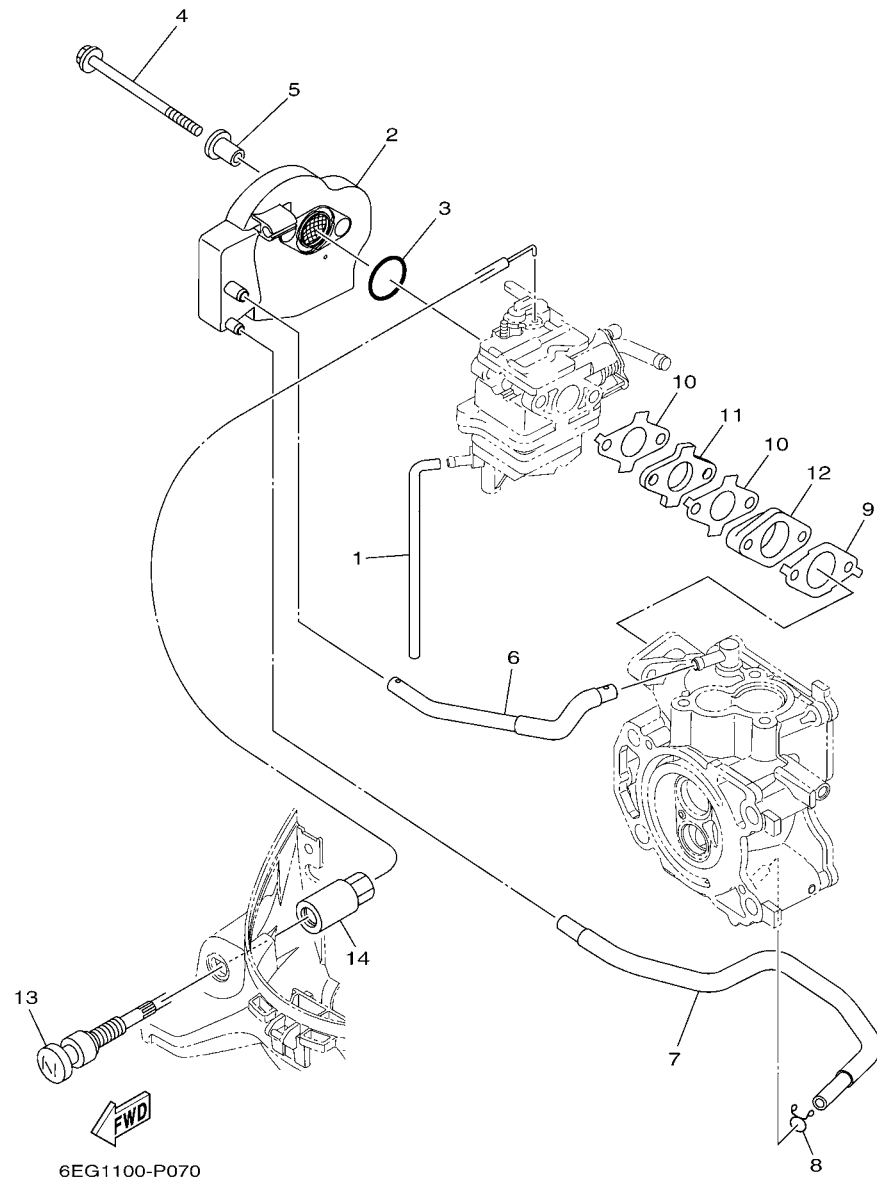

FIG. 7 INTAKE

ADMISSION

REF. NO.	PART NO. N° PIECES	DESCRIPTION DESCRIPTION	6EG1				REMARKS REMARQUES
1	6EG-E4148-00	PIPE DURITE	1				
2	6EG-14440-00	SILENCER ASSY, INTAKE SIENCIEUX D'ADMISSION	1				
3	93210-20801	O-RING JOINT TORIQUE	1				
4	97595-06585	BOLT, WITH WASHER VIS HEXAGONAL AVC RONDELLE	2				
5	90387-06076	COLLAR COLLERETTE	2				
6	6EG-E2483-00	PIPE 3 DURITE 3	1				
7	6EG-E316F-00	HOSE, OIL 1 DURITE A HUILE 1	1				
8	90467-09M09	CLIP JONC	1				
9	6EG-E3645-00	GASKET, MANIFOLD 1 JOINT, TUBULURE 1	1				
10	6EG-E3646-00	GASKET, MANIFOLD 2 JOINT, TUBULURE 2	2				
11	6EG-E3647-00	GASKET, MANIFOLD 3 JOINT, TUBULURE 3	1				
12	6EG-E3641-00	MANIFOLD, INTAKE 1 TUBULURE, ADMISSION 1	1				
13	6EG-F6330-00	STARTER CABLE ASSY CABLE DE STARTER	1				
14	90179-11800	NUT ECROU	1				

FIG. 8 CARBURETOR

CARBURATEUR

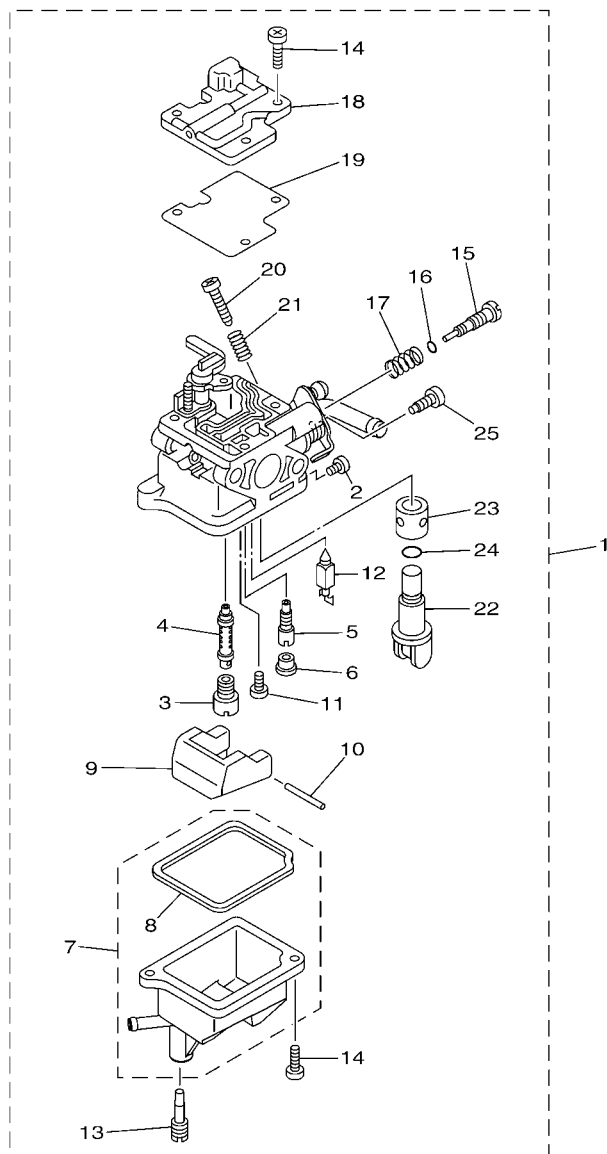

6EG1300-P080

REF. NO.	PART NO. N° PIECES	DESCRIPTION DESCRIPTION	QTY	REMARKS REMARQUES
1	6EG-14301-00	CARBURETOR ASSY 1 CARBURATEUR COMPLET 1	1	
2	97890-04007	.SCREW, PAN HEAD .VIS, CRUCIFORME	1	
3	6EG-14343-3A	.JET, MAIN (#61) .GICLEUR, PRINCIPAL (#61)	1	
4	69M-14341-00	.NOZZLE, MAIN .PUITS D'AIGUILLE	1	
5	69M-14342-68	.JET, PILOT (#37) .GICLEUR, RALENTI (#37)	1	
6	69M-14966-00	.BUSH .BAGUE	1	
7	6EG-14381-00	.BODY, FLOAT CHAMBER .CORPS, CUVE DE FLOTTEUR	1	
8	69M-14984-00	.GASKET, FLOAT CHAMBER .JOINT, CUVE DE FLOTTEUR	1	
9	69M-14385-00	.FLOAT .FLOTTEUR	1	
10	6A1-14386-00	.PIN, FLOAT .AXE, FLOTTEUR	1	
11	98580-03005	.SCREW, PAN HEAD .VIS	1	
12	62Y-14392-00	.VALVE, NEEDLE .POINTEAU	1	
13	69M-14991-00	.SCREW .VIS	1	
14	98580-04010	.SCREW, PAN HEAD .VIS	5	
15	69M-14323-20	.SCREW, AIR ADJUSTING .VIS DE DOSEUR D'AIR	1	
16	2T4-14397-00	.O-RING .JOINT TORIQUE	1	
17	62Y-14334-00	.SPRING, AIR ADJUSTING .RESSORT, VIS DE DOSEUR D'AIR	1	
18	69M-14527-00	.PLATE .PLAQUE	1	
19	69M-14536-00	.GASKET .JOINT	1	
20	69W-14321-00	.SCREW, THROTTLE .VIS, ACCELERATEUR	1	
21	62Y-14212-00	.SPRING, PILOT ADJUSTING .RESSORT, VIS DE RALENTI	1	
22	69M-24524-00	.LEVER, COCK .LEVIER, ROBINET	1	
23	69M-24523-00	.VALVE .SOUPAPE	1	
24	69M-24533-00	.O-RING .JOINT TORIQUE	1	
25	69M-24535-00	.SCREW, LEVER FITTING .VIS, FIXATION DE LEVIER	1	

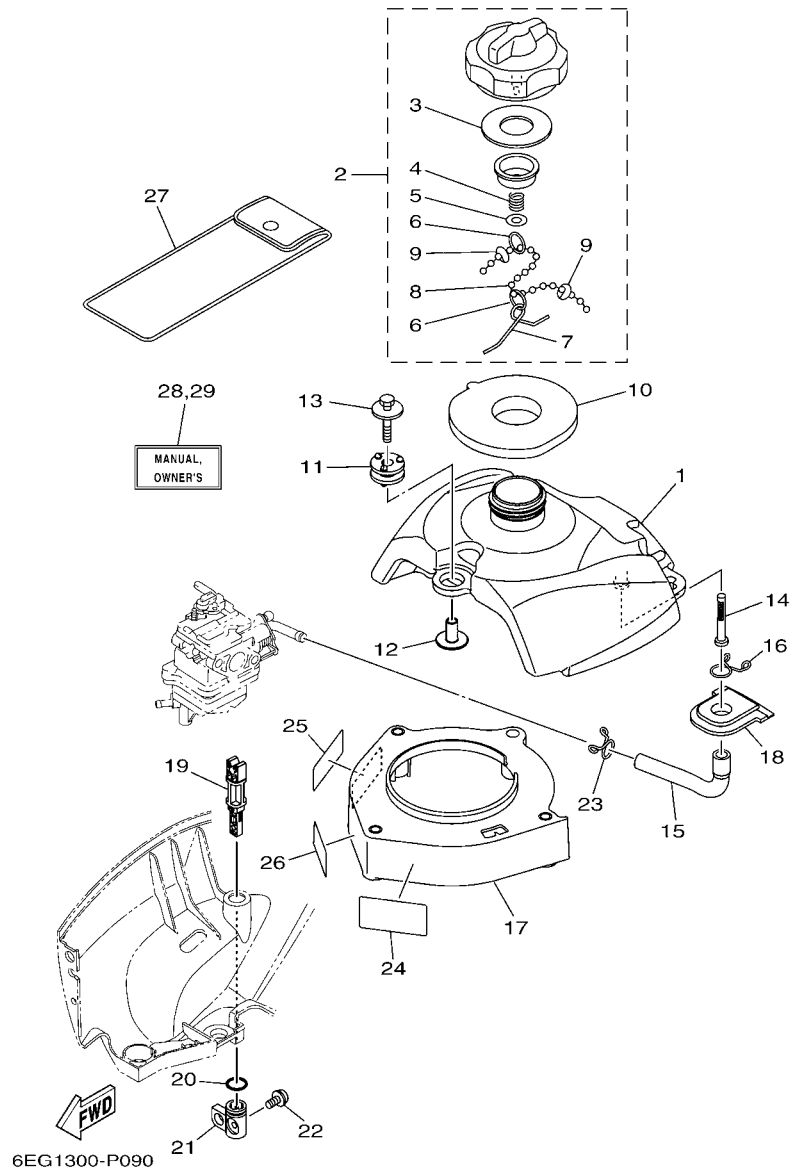

6EG1300-P090

FIG. 9 FUEL

CARBURANT

REF. NO.	PART NO. N° PIECES	DESCRIPTION DESCRIPTION	6EG1			REMARKS REMARQUES
1	6EG-F4111-00	TANK, FUEL RESERVOIR, A ESSENCE	1			
2	68D-24610-10	CAP ASSY BOUCHON	1			
3	68D-24612-00	.PACKING, CAP .JOINT, BOUCHON	1			
4	90501-100A5	.SPRING, COMPRESSION .RESSORT, COMPRESSION	1			
5	92990-04200	.WASHER, PLAIN .RONDELLE, PLATE	1			
6	90468-100A0	.CLIP .JONC	2			
7	624-24634-00	.HOOK, CHAIN BALL .ATTACHE	1			
8	69M-24633-00	.CHAIN, BALL .CHANE DE BALLE	1			
9	67D-21757-00	.WASHER, SPECIAL 1 .RONDELLE, SPECIALE 1	2			
10	6EG-24641-00	GASKET, CAP 1 JOINT 1, BOUCHON	1			
11	6EG-F4375-00	GROMMET OEILLET CAOUTCHOUC	3			
12	90387-06176	COLLAR COLLERETTE	3			
13	90119-06098	BOLT, WITH WASHER BOULON, AVEC RONDELLE	3			
14	6L5-24251-00	STRAINER 1 FILTRE 1	1			
15	6EG-F4311-00	PIPE, FUEL 1 DURITE A ESSENCE	1			
16	90467-13M13	CLIP .JONC	1			
17	6EG-F4191-00	BRACKET, FUEL TANK 1 SUPPORT 1, RESERVOIR A ESSENCE	1			
18	6EG-F4181-00	DAMPER, LOCATING 1 SILENT-BLOC 1	1			
19	6EG-F4554-00	SHAFT, COCK AXE, MANETTE DU ROBINET	1			
20	93210-128F6	O-RING JOINT TORIQUE	1			
21	6EG-F4575-00	LEVER, FUEL CHANGE LEVIER, D'ESSENCE	1			
22	90159-05M12	SCREW, WITH WASHER VIS, AVEC RONDELLE	1			
23	90467-11M08	CLIP .JONC	1			
24	6EG-E3437-60	MARK, CAUTION MAKER	1			
25	6EE-H1994-40	LABEL, SAFETY ETIQUETTE, SECURITE	1			
26	6EE-H1994-50	LABEL, SAFETY ETIQUETTE, SECURITE	1			
27	6EE-F8100-00	TOOL KIT TROUSSE A OUTILS	1			AP AP

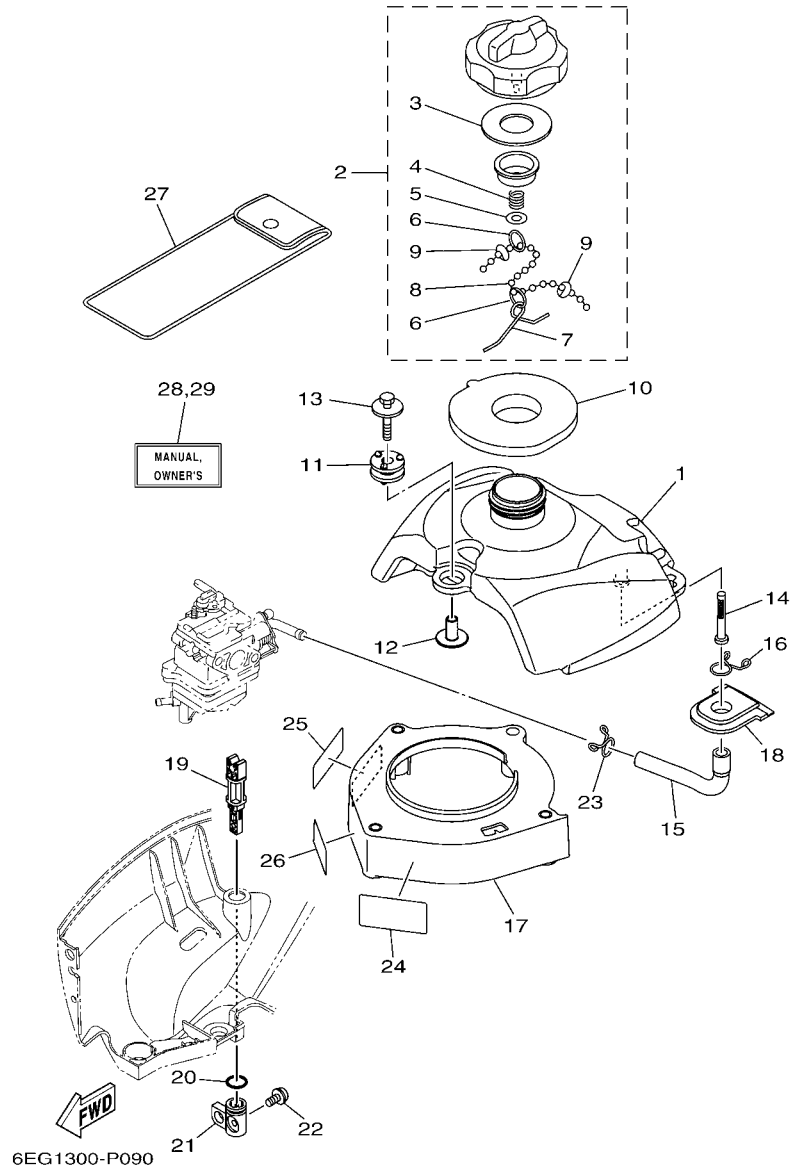

FIG. 9 FUEL

CARBURANT

REF. NO.	PART NO. N° PIECES	DESCRIPTION DESCRIPTION	6EG1			REMARKS REMARQUES
28	6EG-F8199-70-E0	MANUAL, OWNER'S MANUEL D'UTILISATION	1			UR (E) UR (E)
	6EG-F8199-70-F0	MANUAL, OWNER'S MANUEL D'UTILISATION	1			UR (F) UR (F)
	6EG-F8199-70-S0	MANUAL, OWNER'S MANUEL D'UTILISATION	1			UR (ES) UR (ES)
	6EG-F8199-70-G0	MANUAL, OWNER'S MANUEL D'UTILISATION	1			UR (D) UR (D)
	6EG-F8199-70-D0	MANUAL, OWNER'S MANUEL D'UTILISATION	1			UR (NL) UR (NL)
	6EG-F8199-70-H0	MANUAL, OWNER'S MANUEL D'UTILISATION	1			UR (I) UR (I)
29	6EG-F8199-80-K0	MANUAL, OWNER'S MANUEL D'UTILISATION	1			UR (DK) UR (DK)
	6EG-F8199-80-R0	MANUAL, OWNER'S MANUEL D'UTILISATION	1			UR (GR) UR (GR)
	6EG-F8199-80-P0	MANUAL, OWNER'S MANUEL D'UTILISATION	1			UR (P) UR (P)
	6EG-F8199-80-N0	MANUAL, OWNER'S MANUEL D'UTILISATION	1			UR (N) UR (N)
	6EG-F8199-80-M0	MANUAL, OWNER'S MANUEL D'UTILISATION	1			UR (S) UR (S)
	6EG-F8199-80-L0	MANUAL, OWNER'S MANUEL D'UTILISATION	1			UR (SF) UR (SF)

FIG. 10 STARTER

DEMARREUR

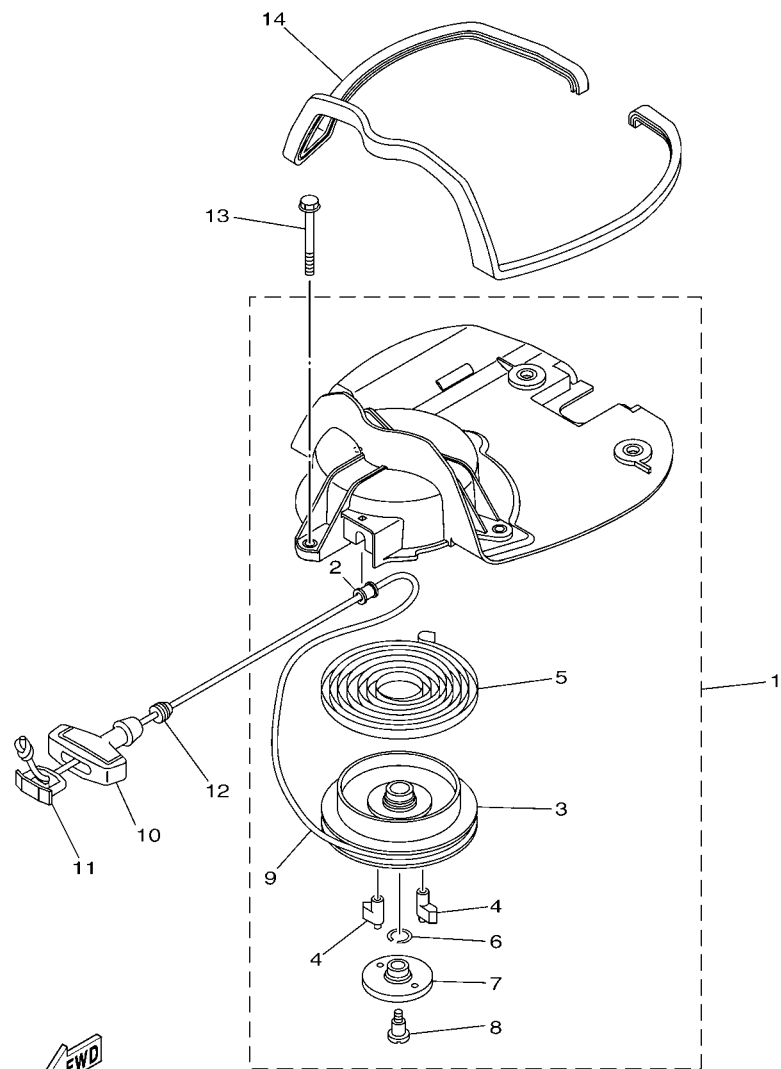

6EG1100-P100

REF. NO.	PART NO. N° PIECES	DESCRIPTION DESCRIPTION	6EG1				REMARKS REMARQUES
1	6EG-E5710-00	STARTER ASSY DEMARREUR COMPLET	1				
2	63V-15764-00	.COLLAR 1 .COLLERETTE 1	1				
3	69M-E5714-00	.DRUM, SHEAVE .TAMBOUR, POULIE	1				
4	69M-15741-00	.PAWL, DRIVE .CLIQUET, ENTRAINEMENT	2				
5	67D-15713-00	.SPRING, STARTER .RESSORT DE DEMARREUR	1				
6	6BX-15705-00	.SPRING, DRIVE PAWL .RESSORT DE CLIQUET	1				
7	69M-15735-00	.GUIDE, CAM .COULISSEAU	1				
8	69M-15793-00	.SCREW .VIS	1				
9	6EG-E5751-00	.WIRE, STARTER (L:1500MM) .CABLE DE DEMARREUR (L:1500MM)	1				
10	6G1-15755-00	HANDLE, STARTER POIGNEE, DE DEMARREUR	1				
11	6G1-15779-00	COVER COUVERCLE	1				
12	6EG-E5789-00	DAMPER AMORTISSEUR	1				
13	97595-06560	BOLT, WITH WASHER VIS HEXAGONAL AVEC RONDELLE	3				
14	6EG-F4182-00	DAMPER, LOCATING 2 SILENT-BLOC	1				

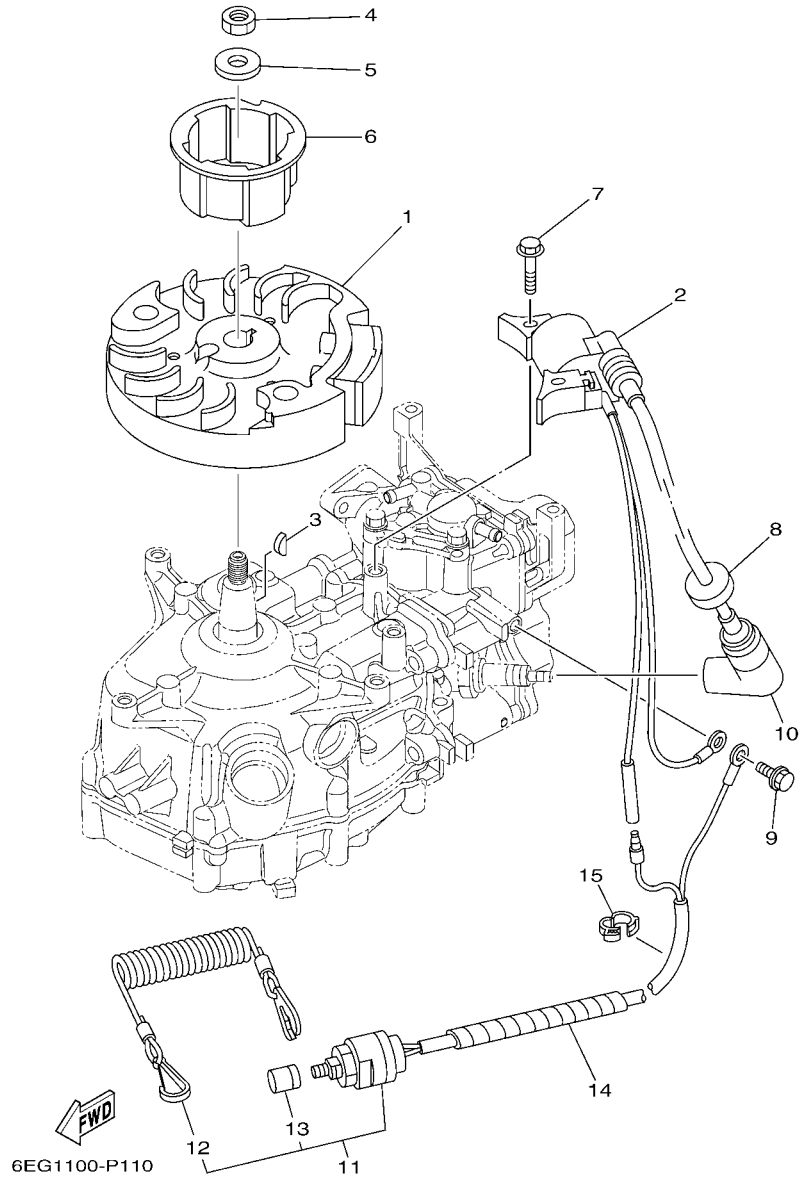

FIG. 11 GENERATOR

GENERATRICE

REF. NO.	PART NO. N° PIECES	DESCRIPTION DESCRIPTION	BEG1				REMARKS REMARQUES
1	69M-85650-00	ROTOR ASSY ROTOR COMPLET	1				
2	69M-85640-00	T.C.I. UNIT ASSY ENS. BLOC T.C.I.	1				
3	90280-04M06	KEY, WOODRUFF CLAVETTE, DEMI-LUNE	1				
4	90170-10M33	NUT ECROU	1				
5	90201-105A2	WASHER, PLATE RONDELLE, PLATE	1				
6	69M-15723-00	PULLEY, STARTER POULIE DE DEMARREUR	1				
7	90105-06M24	BOLT, FLANGE BOULON	2				
8	90480-25161	GROMMET PASSE-FIL	1				
9	97595-06512	BOLT, WITH WASHER VIS HEXAGONAL AVC RONDELLE	1				
10	6BX-82370-00	PLUG CAP ASSY ANTIPARASITE	1				
11	65W-82575-01	ENGINE STOP SWITCH ASSY COUPE CIRCUIT CPLT	1				
12	682-82556-00	.LANYARD, STOP SWITCH .CORDON DU COUPE CIRCUIT	1				
13	689-8257Y-00	.CAP .COUVERCLE	1				
14	90446-06M90	HOSE (L120) DURITE (L120)	1				
15	90464-16003	CLAMP BRIDE	1				

FIG. 12 BOTTOM COWLING

CAPOT INFERIEUR

REF. NO.	PART NO. N° PIECES	DESCRIPTION DESCRIPTION	6EG1				REMARKS REMARQUES
1	6EG-G2711-00	COWLING, BOTTOM 1 CUVETTE 1	1				
2	6EG-42628-00	SEAL JOINT	1				
3	6EG-42629-00	SEAL JOINT	1				
4	6EG-G2774-00	STAY, APRON 1 COUSSINET	2				
5	90157-05013	SCREW, PAN HEAD VIS, TETE TRONCONIQUE	2				
6	6EG-G2712-00	COWLING, BOTTOM 2 CUVETTE 2	1				
7	6EG-G2727-00	GROMMET PASSE-FIL	1				
8	6EG-G2724-00	GROMMET PASSE-FIL	1				
9	647-45151-01	COVER, UPPER CASING CAPUCHON, FOURREAU	1				
10	6EG-E5316-00	DAMPER 1 AMORTISSEUR 1	1				
11	90387-068N9	COLLAR COLLERETTE	4				
12	6EG-G2768-00	DAMPER AMORTISSEUR	4				
13	90119-06M17	BOLT, WITH WASHER BOULON, AVEC RONDELLE	4				
14	6L5-42647-00	HOLDER, CLAMP BAND SUPPORT, SANDOW DE SERRAGE	2				
15	6EG-G2823-00	PLATE, STOP PLAQUE	2				
16	90167-03M02	SCREW, TAPPING VIS, TETE FRAISEE	2				
17	6EG-G4532-00	STOPPER, UPPER MOUNT PLAQUETTE	1				
18	6EG-F4591-00	EMBLEM, FUEL COCK ADHESIF	1				

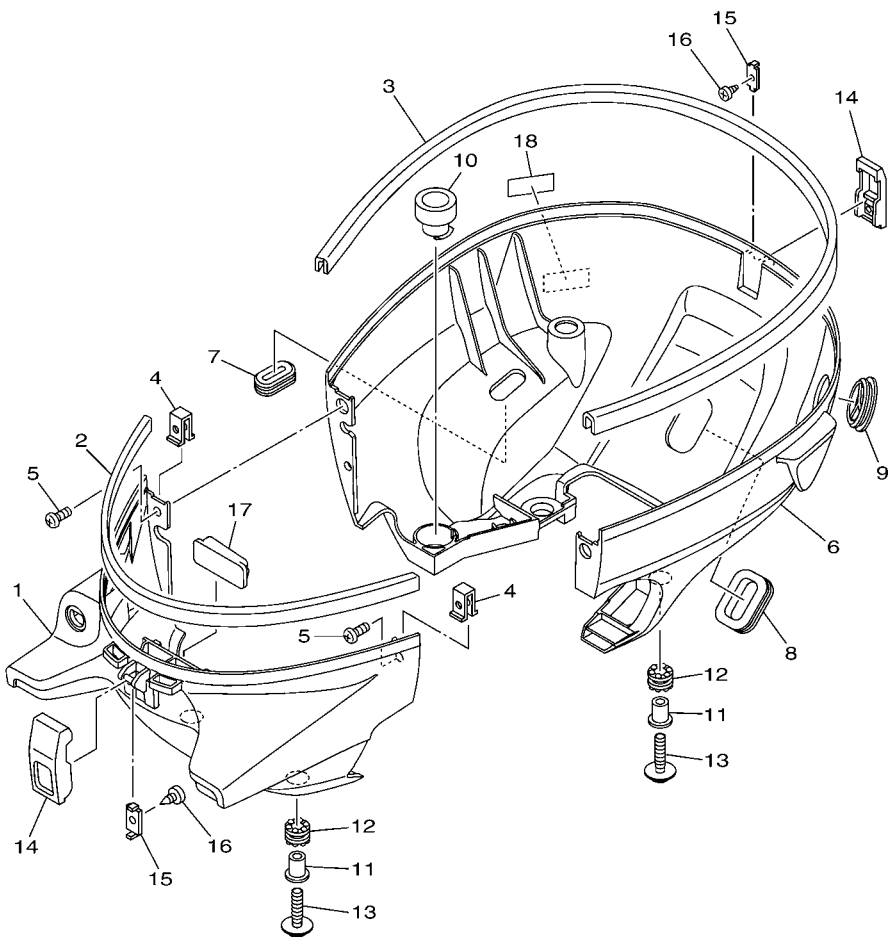

6EG1100-P120

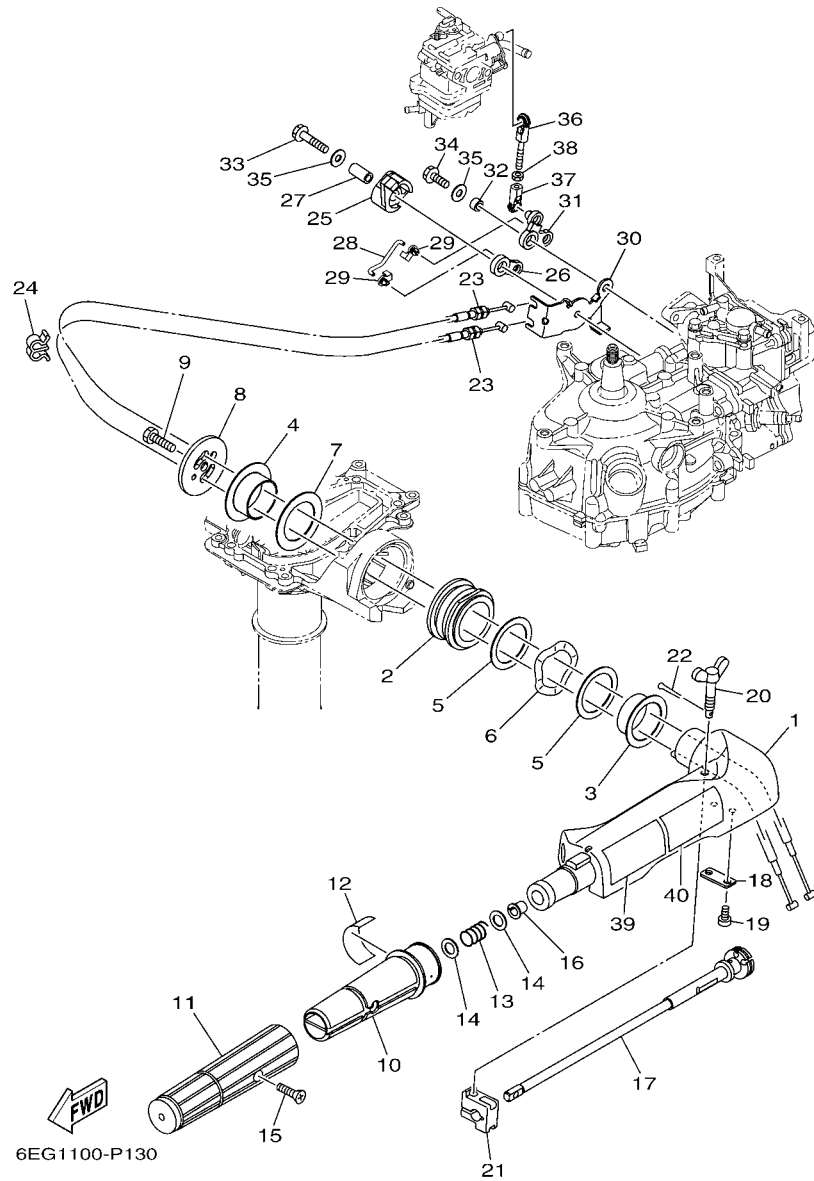

FIG. 13 STEERING

DIRECTION

REF. NO.	PART NO. N° PIECES	DESCRIPTION DESCRIPTION	6EG1			REMARKS REMARQUES
1	6EG-G2111-00-8D	HANDLE, STEERING POIGNEE	1			
2	6BX-42129-00	BUSHING, RUBBER DOUILLE, CAOUTCHOUC	1			
3	6EE-G2171-00	BUSHING COUSSINET	1			
4	6EE-G2172-00	BUSHING 2 DOUILLE 2	1			
5	6EE-G2181-00	WASHER RONDELLE	2			
6	6EE-G2188-00	WASHER, WAVE RONDELLE, ONDULEE	1			
7	6EE-G2182-00	WASHER 2 RONDELLE 2	1			
8	6EE-G2131-00	COVER, HANDLE STEERING COUVERCLE	1			
9	97075-08025	BOLT BOULON	1			
10	6EG-G2119-00	GRIP, STEERING HANDLE POIGNEE, BARRE FRANCHE	1			
11	6EG-G2177-00	RUBBER, HANDLE CAOUTCHOUC, POIGNEE	1			
12	6EG-G2137-00	INDICATOR, THROTTLE INDICATEUR, ACCELERATION	1			
13	90501-23215	SPRING, COMPRESSION RESSORT, COMPRESSION	1			
14	90201-10M02	WASHER, PLATE RONDELLE, PLATE	2			
15	90152-05014	SCREW, COUNTERSUNK VIS. TETE NOYEE	1			
16	90386-08032	BUSH DOUILLE	1			
17	6EG-G2138-00	LEVER, THROTTLE LEVIER, ACCELERATEUR	1			
18	6EE-G2159-00	STAY SUPPORT	1			
19	97885-05012	SCREW, PAN HEAD VIS. A ENCOCHE	2			
20	6G1-42125-01	BOLT, FRICTION ADJUSTING BOULON	1			
21	6EE-G2126-00	FRICTION, STEERING HANDLE GRIP CUVETTE, POIGNEE DE DIRECTION	1			
22	91490-16010	PIN, COTTER GOUILLE	1			
23	6EG-F6301-00	THROTTLE CABLE ASSY CABLE D'ACCELERATEUR	2			
24	90464-07M20	CLAMP BRIDE	1			
25	6EE-G1638-00	PULLEY POULIE	1			
26	6EG-G1283-00	LEVER, FREE ACCEL. LEVIER	1			
27	90387-06252	COLLAR COLLERETTE	1			

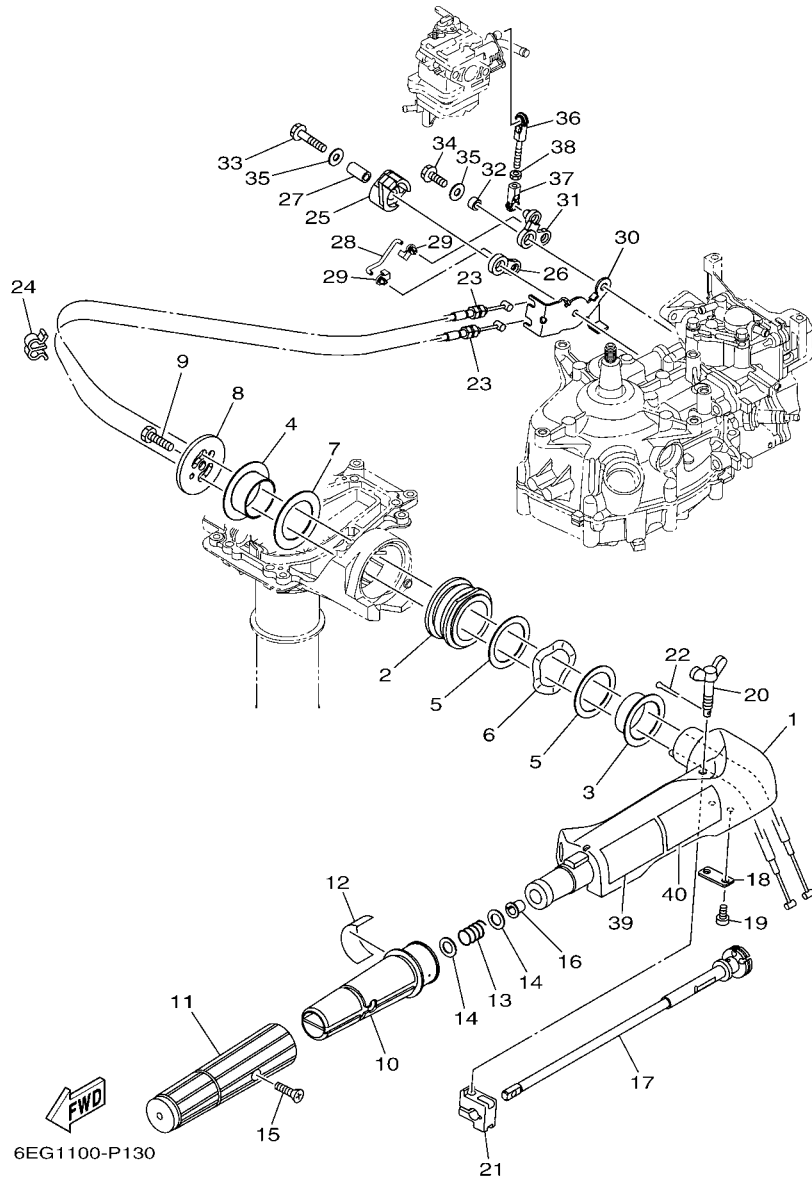

FIG. 13 STEERING

DIRECTION

REF. NO.	PART NO. N° PIECES	DESCRIPTION DESCRIPTION	6EG1				REMARKS REMARQUES
28	6EG-G1211-00	LINK, ACCEL. BIELLETTE, ACCELERATION	1				
29	661-41262-02	JOINT, CHOKE LEVER RACCORD, LEVIER DE STARTER	2				
30	6EG-E4497-00	STAY, THROTTLE WIRE SUPPORT DE BOISSEAU	1				
31	6EG-G1284-00	LEVER, FREE AXLE 2 LEVIVER, ARBRE 2	1				
32	90387-06M24	COLLAR COLLERETTE	1				
33	97595-06535	BOLT, WITH WASHER VIS HEXAGONAL AVC RONDELLE	1				
34	97595-06520	BOLT, WITH WASHER VIS HEXAGONAL AVC RONDELLE	1				
35	90201-06M62	WASHER, PLATE RONDELLE, PLATE	2				
36	682-41237-50	JOINT, LINK RACCORD	1				
37	6H1-41237-00	JOINT, LINK RACCORD	1				
38	95380-05600	NUT ECROU	1				
39	6EF-G2794-40	LABEL, WARNING (GENERAL) ETIQUETTE, AVERTISSEMENT	1				
40	6EF-G2794-50	LABEL, WARNING (GENERAL) ETIQUETTE, AVERTISSEMENT	1				

FIG. 14 CONTROL

COMMANDE

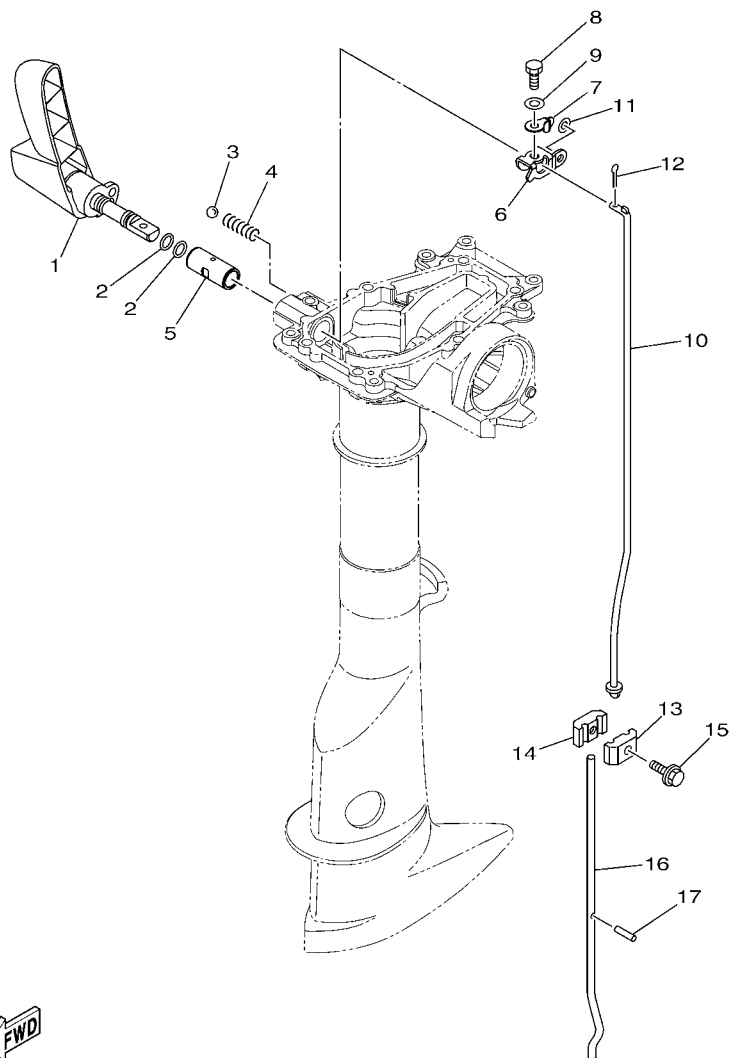

6EG1100-P140

REF. NO.	PART NO. N° PIECES	DESCRIPTION DESCRIPTION	QTY	REMARKS REMARQUES
1	6EG-G4111-00	HANDLE, GEAR SHIFT POIGNEE, LEVIER D'EMBRAYAGE	1	
2	93210-09811	O-RING JOINT TORIQUE	2	
3	93505-16024	BALL BILLE	1	
4	90501-12802	SPRING, COMPRESSION RESSORT, COMPRESSION	1	
5	68D-G4122-01	BUSHING, SHIFT ROD LEVER DOUILLE, LEVIER D'EMBRAYAGE	1	
6	6EG-G4121-00	LEVER, SHIFT ROD LEVIER, TIGE D'INVERSION	1	
7	6EG-G4126-00	WASHER, SHIFT ROD LEVER RONDELLE, TIGE D'INVERSION LEV	1	
8	97095-05012	BOLT BOULON	1	
9	92995-05600	WASHER RONDELLE	1	
10	69M-44143-00	ROD, SHIFT TIGE D'EMBRAYAGE	1	
11	92990-05600	WASHER, PLATE RONDELLE, PLATE	1	
12	91490-16010	PIN, COTTER GOUPILLE	1	
13	6N0-G4145-10	CONNECTOR, SHIFT ROD 1 CONNECTEUR, TIGE D'INVERSION 1	1	
14	6N0-G4146-10	CONNECTOR, SHIFT ROD 2 CONNECTEUR, TIGE D'INVERSION 2	1	
15	90119-06ME0	BOLT, WITH WASHER BOULON, AVEC RONDELLE	1	
16	6EG-G4144-00	ROD, SHIFT TIGE D'EMBRAYAGE	1	S(17.0")
	6EG-G4144-10	ROD, SHIFT TIGE D'EMBRAYAGE	1	S(17.0") L(22.0")
17	91609-25014	PIN, SPRING AXE DE RESSORT	1	L(22.0")

FIG. 15 BRACKET

SUPPORT

REF. NO.	PART NO. N° PIECES	DESCRIPTION DESCRIPTION	BEG1				REMARKS REMARQUES
1	6EG-G3111-00-8D	BRACKET, CLAMP 1 PRESSE 1	2				
2	6E0-43116-01	SCREW, TRANSOM CLAMP VIS DE PRESSE	2				
3	6EE-G3118-00	HANDLE, TRANSOM CLAMP POIGNEE DE VIS DE PRESSE	2				
4	90243-04M01	PIN GOUPILLE	2				
5	648-43114-01	PAD, TRANSOM CLAMP RONDELLE D'APPUI	2				
6	90101-08M07	BOLT BOULON	1				
7	90202-08022	WASHER, PLATE RONDELLE, PLATE	1				
8	90202-08004	WASHER, PLATE RONDELLE, PLATE	1				
9	92990-08200	WASHER, PLAIN RONDELLE, PLATE	1				
10	95380-08600	NUT ECROU	1				
11	95380-08700	NUT ECROU	1				
12	6EG-G3311-00-8D	BRACKET, SWIVEL 1 SUPPORT, PIVOT 1	1				
13	6EG-G3312-00-8D	BRACKET, SWIVEL 2 SUPPORT, PIVOT 2	1				
14	6EG-G2537-00	BUSHING, PIVOT SHAFT COUSSINET	1				
15	6EG-G2538-00	BUSHING, PIVOT SHAFT COUSSINET	1				
16	97075-06030	BOLT BOULON	4				
17	92995-06600	WASHER RONDELLE	4				
18	6EG-G3679-00	COVER COUVERCLE	1				
19	6EG-G3180-00	TILT STOP LEVER ASSY LEVIER, VERROUILLAGE RELEVAGE	1				
20	6EG-G3188-00	SPRING RESSORT	1				
21	6EG-G3186-00	LEVER LEVIER	1				
22	90386-08032	BUSH DOUILLE	1				
23	91690-20010	PIN, SPRING AGRAFFE	1				
24	6EG-G3185-00	LEVER, TILT STOP 2 LEVIER VERROUILLAGE RELEVAGE 2	1				
25	6EG-G3164-00	ROD, TILT LOCK TIGE	1				
26	6EG-G3166-00	PIN GOUPILLE	1				
27	99080-04600	CIRCLIP CIRCLIP	1				

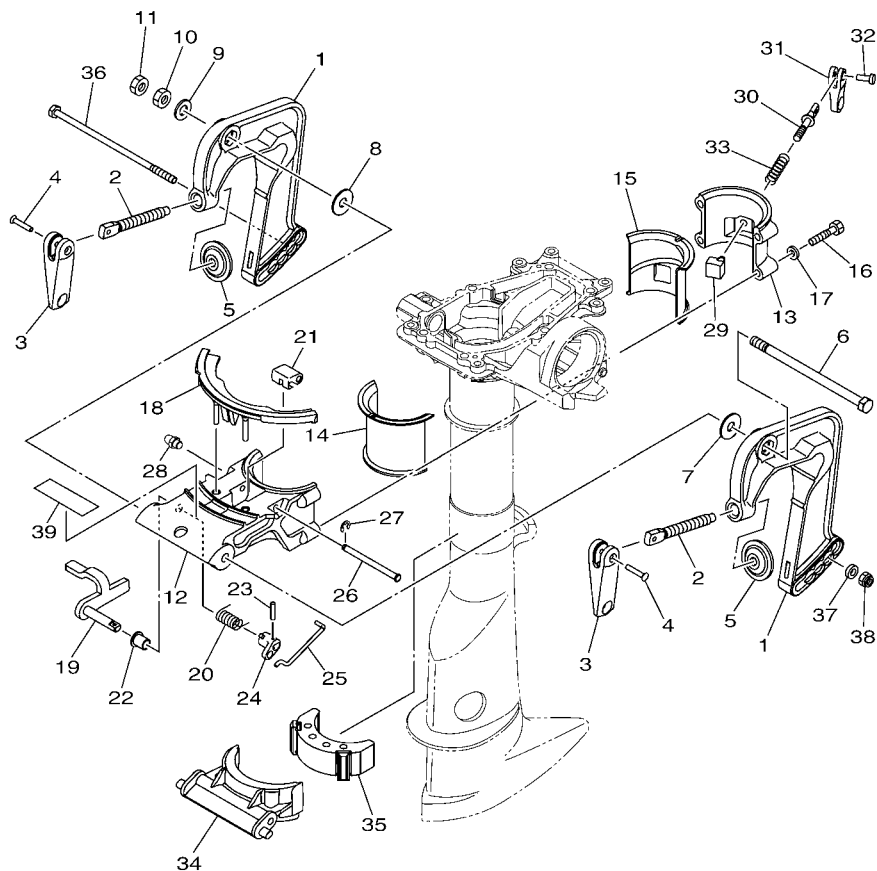

6EG1100-P150

FIG. 15 BRACKET

SUPPORT

REF. NO.	PART NO. N° PIECES	DESCRIPTION DESCRIPTION	6EG1				REMARKS REMARQUES
28	93700-06M03	NIPPLE, GREASE PION	1				
29	69M-42528-00	PLATE, FRICTION PLAQUE, FRICTION	1				
30	6EG-G2529-00	SCREW, FRICTION PIECE VIS, PIECE DE FRICTION	1				
31	6EE-G2561-00	KNOB, STEERING LOCK BOUTON	1				
32	90266-04M05	RIVET RIVET	1				
33	90501-12803	SPRING, COMPRESSION RESSORT, COMPRESSION	1				
34	6EG-G3351-00	RECEIVER, THRUST SILENT-BLOC, BUTEE	1				
35	69M-44557-00	MOUNT DAMPER, LOWER FRONT SILENT-BLOC, INFERIEUR AVANT	1				
36	90101-06062	BOLT BOULON	1				
37	90201-06040	WASHER, PLATE RONDELLE, PLATE	1				
38	95780-06300	NUT, FLANGE ECROU	1				
39	6EG-G3691-00	INDICATOR, TILT ETIQUETTE, RELEVAGE	1				

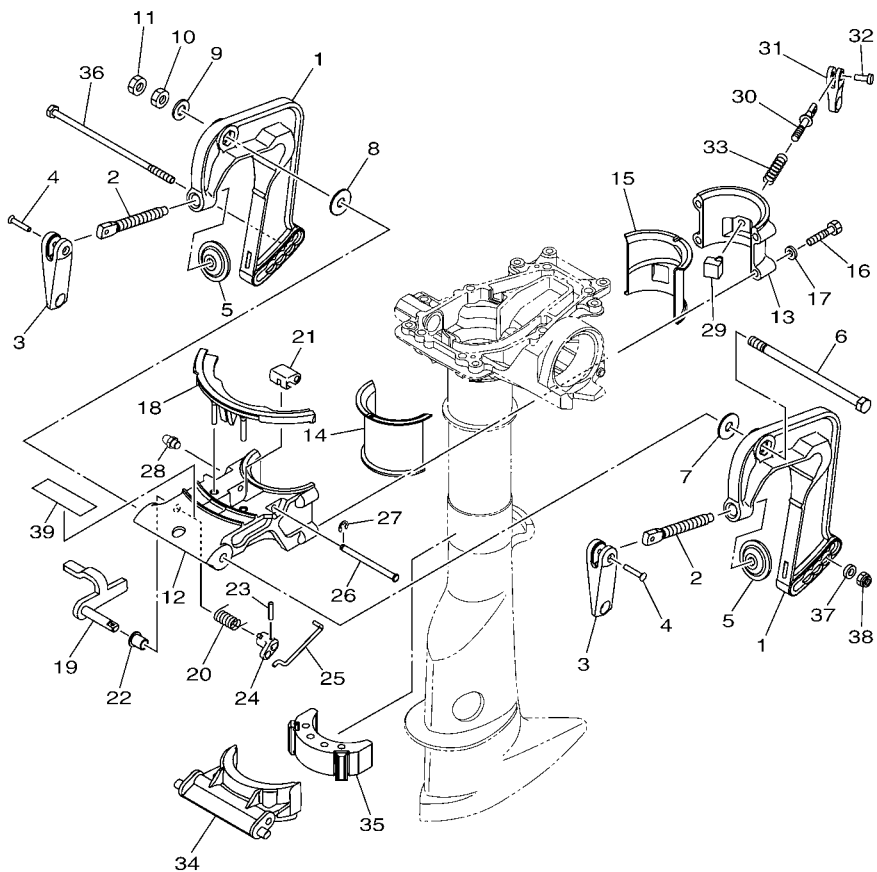

6EG1100-P150

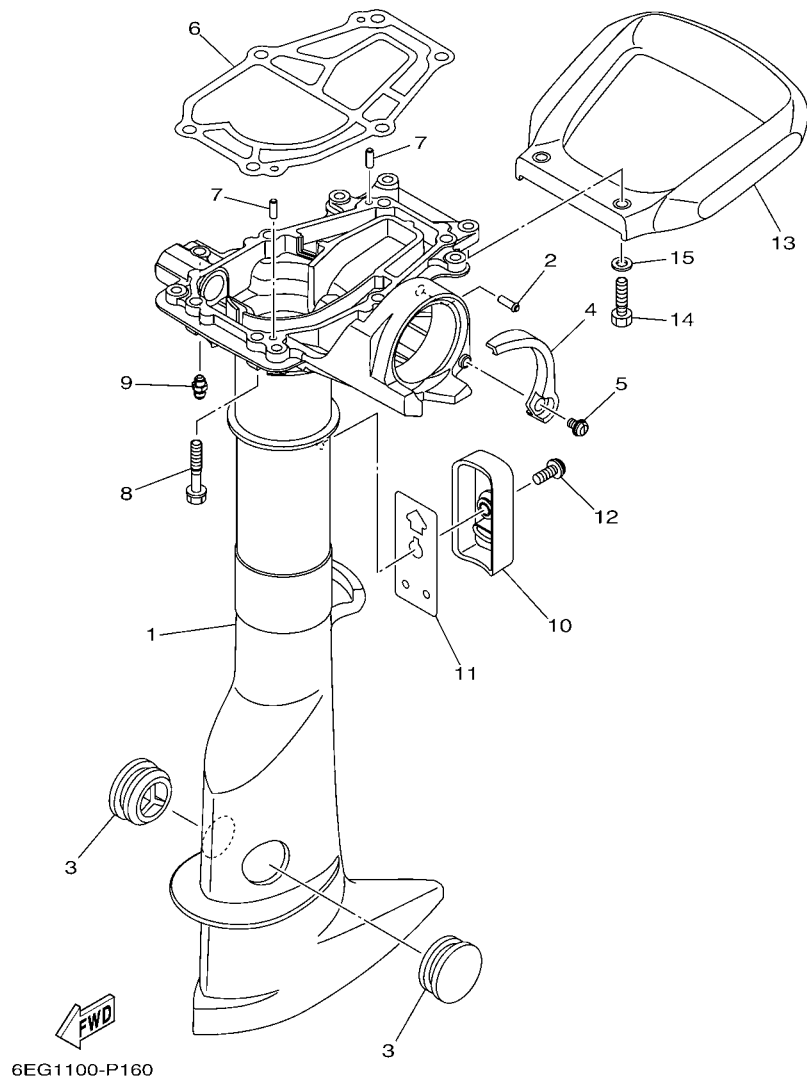

FIG. 16 UPPER CASING

FOURREAU

REF. NO.	PART NO. N° PIECES	DESCRIPTION DESCRIPTION	6EG1			REMARKS REMARQUES
1	6EG-G5111-00-8D	CASING, UPPER FOURREAU	1			
2	6EE-F4377-00	PIPE, JOINT 2 DURITE RACCORDEMENT 2	1			
3	647-45151-01	COVER, UPPER CASING CAPUCHON, FOURREAU	2			
4	6EG-G5152-00	COVER, UPPER CASING 2 CAPUCHON FOURREAU	1			
5	90159-05M12	SCREW, WITH WASHER VIS, AVEC RONDELLE	1			
6	6EG-G5113-00	GASKET, UPPER CASING JOINT, TUBE D'ARBRE	1			
7	93604-12M07	PIN, DOWEL CLAVETTE	2			
8	97575-06535	BOLT, WITH WASHER VIS HEXAGONAL AVC RONDELLE	6			
9	93700-06M03	NIPPLE, GREASE PION	1			
10	6EG-G5151-00	COVER, UPPER CASING CAPUCHON, FOURREAU	1			
11	6EG-G5115-00	GASKET, UPPER CASING JOINT, TUBE D'ARBRE	1			
12	90159-06M11	SCREW, WITH WASHER VIS, AVEC RONDELLE	1			
13	6EG-G2731-00	CARRYING HANDLE POIGNEE DE PORTAGE	1			
14	97095-06025	BOLT BOULON	2			
15	92995-06600	WASHER RONDELLE	2			

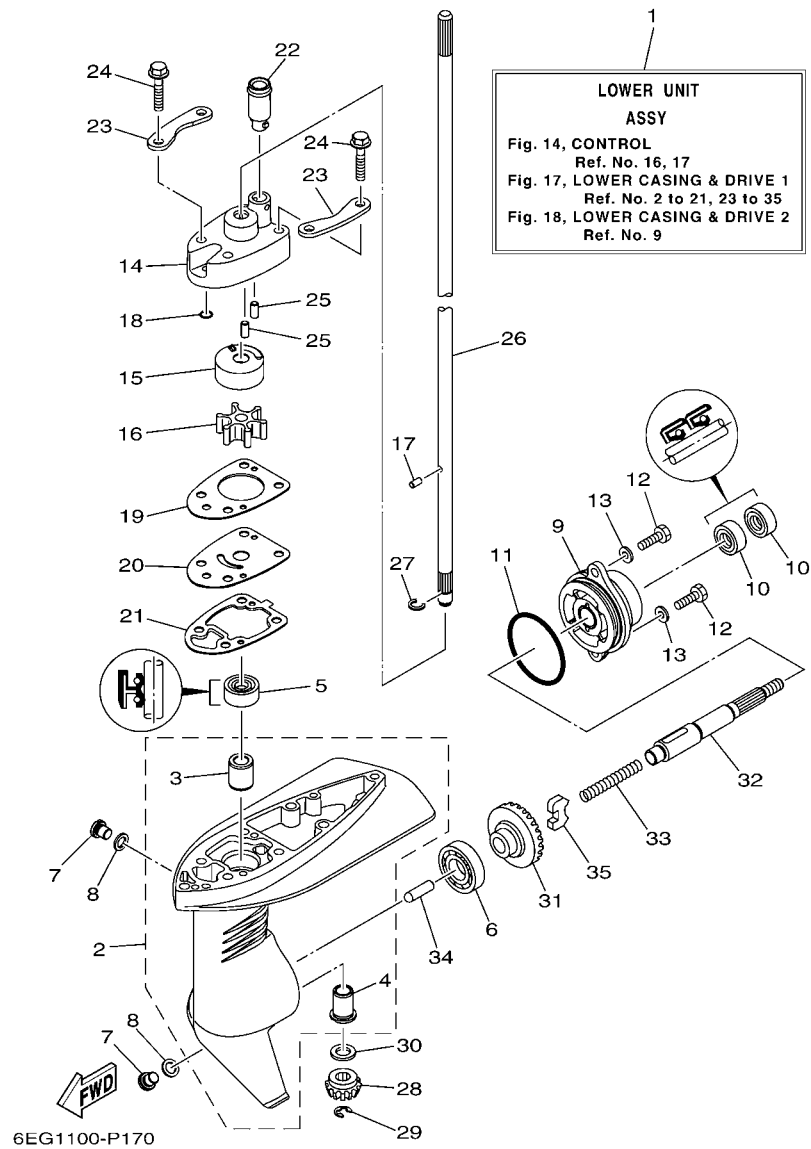

FIG. 17 LOWER CASING & DRIVE 1

BOITIER D'HELICE TRANSMISSION1

REF. NO.	PART NO. N° PIECES	DESCRIPTION DESCRIPTION	6EG1		REMARKS REMARQUES
1	6EG-G5300-00-8D	LOWER UNIT ASSY UNITE INFERIEURE (ENS.)	1		S(17.0") S(17.0")
	6EG-G5300-10-8D	LOWER UNIT ASSY UNITE INFERIEURE (ENS.)	1		L(22.0") L(22.0")
2	6EG-G5311-00-8D	CASING, LOWER BOITIER D'HELICE	1		
3	6L5-45316-09	.BUSHING, DRIVE SHAFT .DOUILLE, ARBRE MOTEUR	1		
4	6L5-45317-09	.BUSHING, DRIVE SHAFT .DOUILLE, ARBRE MOTEUR	1		
5	93103-09800	OIL SEAL JOINT SPY	1		
6	93316-003Y0	BEARING ROULEMENT	1		
7	90340-08002	PLUG, STRAIGHT SCREW PLOT, FILETE DROIT	2		
8	90430-08020	GASKET JOINT	2		
9	6EG-G5361-00-8D	CAP, LOWER CASING COUVERCLE, BOITIER D'HELICE	1		
10	93101-13800	OIL SEAL JOINT SPY	2		
11	93210-48800	O-RING JOINT TORIQUE	1		
12	97095-06016	BOLT BOULON	2		
13	92995-06600	WASHER RONDELLE	2		
14	6EG-G4311-00	HOUSING, WATER PUMP CORPS, POMPE A EAU	1		
15	6EG-G4322-00	INSERT, CARTRIDGE CUVETTE	1		
16	6L5-44352-00	IMPELLER TURBINE	1		
17	93604-07M13	PIN, DOWEL CLAVETTE	1		
18	93210-05001	O-RING JOINT TORIQUE	1		
19	6EG-G4315-00	GASKET, WATER PUMP JOINT, POMPE A EAU	1		
20	6EG-G4323-00	OUTER PLATE, CARTRIDGE PLAQUE EXTERIEURE	1		
21	6EG-G5315-00	PACKING, LOWER CASING JOINT, BOITIER D'HELICE	1		
22	6EE-G4366-00	DAMPER, WATER SEAL 2 JOINT, TUBE D'EAU 2	1		
23	6EG-G4328-00	PLATE PLAQUETTE	2		
24	97595-06535	BOLT, WITH WASHER VIS HEXAGONAL AVC RONDELLE	4		
25	93604-12M07	PIN, DOWEL CLAVETTE	2		
26	6EG-G5511-00	SHAFT, DRIVE ARBRE, MOTEUR	1		S(17.0") S(17.0")

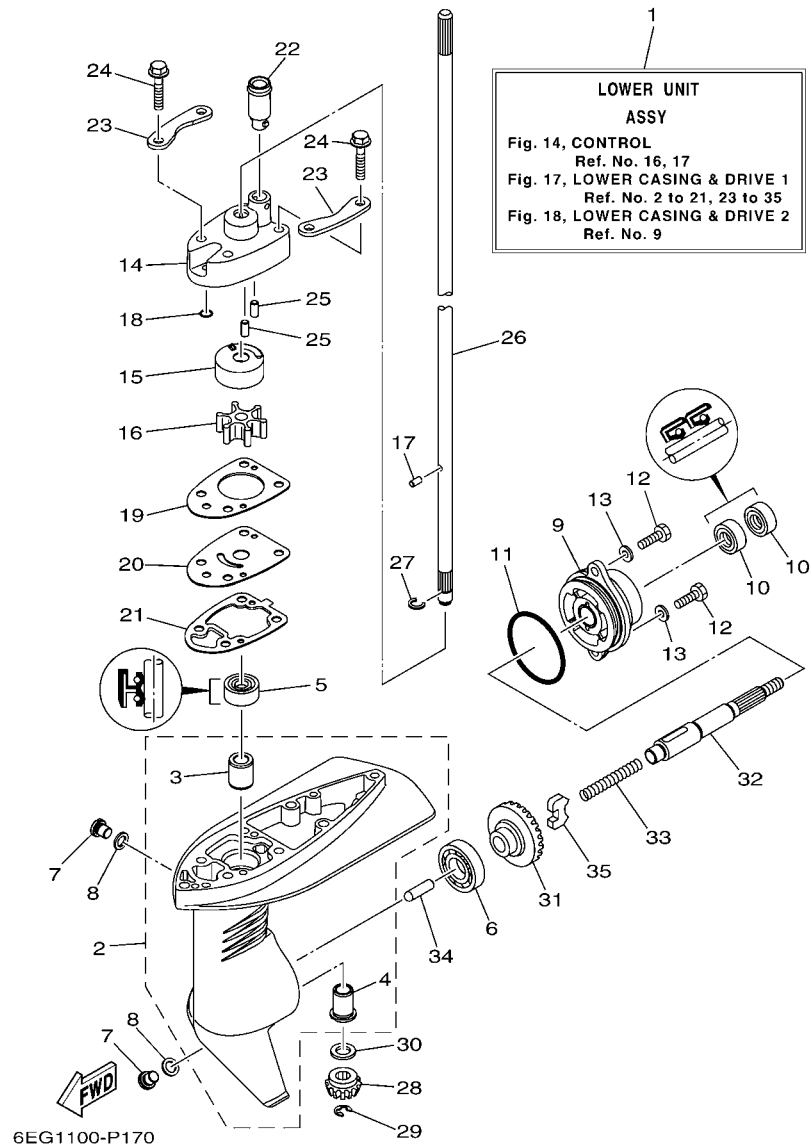
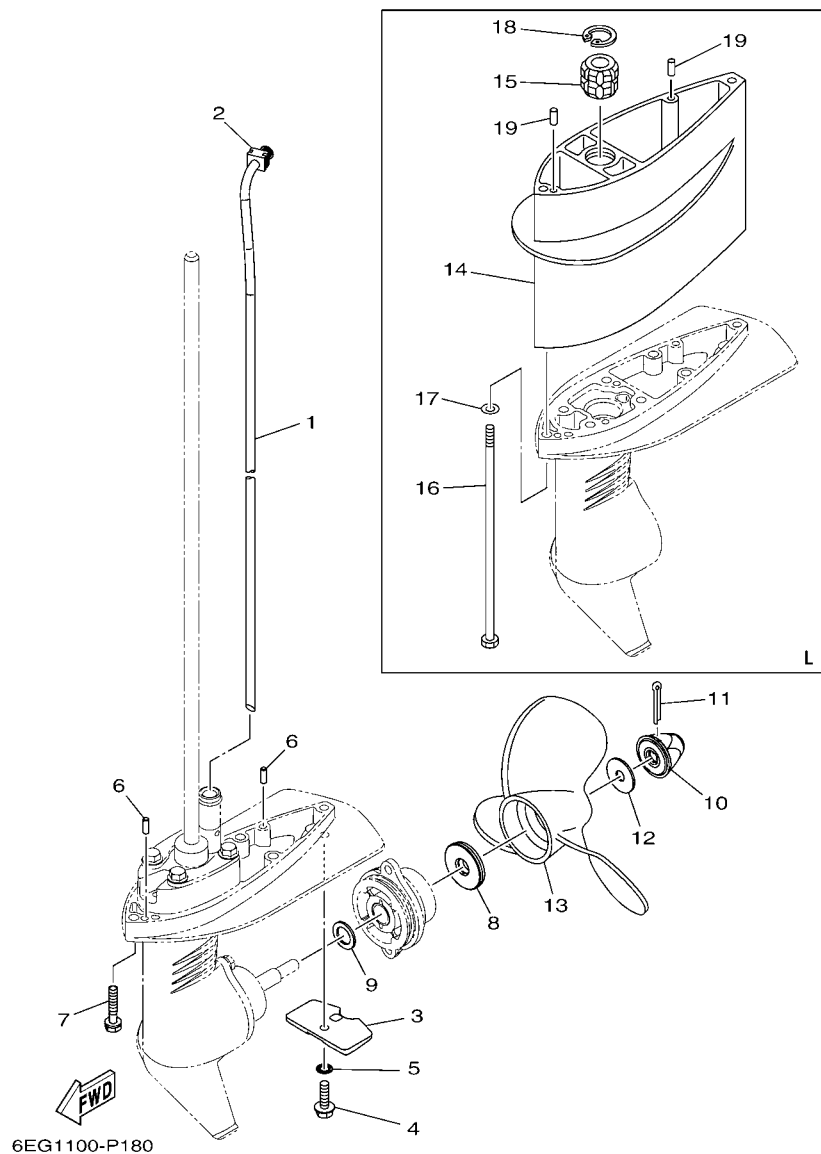

FIG. 17 LOWER CASING & DRIVE 1

BOITIER D'HELICE TRANSMISSION1

REF. NO.	PART NO. N° PIECES	DESCRIPTION DESCRIPTION	6EG1			REMARKS REMARQUES
26	6EG-G5511-10	SHAFT, DRIVE ARBRE, MOTEUR	1			L(22.0") L(22.0")
27	90467-07M12	CLIP JONC	1			
28	6L5-45551-00	PINION (13T) PIGNON D'ATTAQUE (13D)	1			
29	99001-06600	CIRCLIP CIRCLIP	1			
30	6EG-G5533-00	SHIM CALE	1			
31	6L5-45560-00	GEAR 1 (27T) PIGNON 1 (27T)	1			
32	6EG-G5611-00	SHAFT, PROPELLER ARBRE, HELICE	1			
33	90501-10064	SPRING, COMPRESSION RESSORT, COMPRESSION	1			
34	6EG-G5635-00	PLUNGER, SHIFT POUSSOIR D'EMBAYAGE	1			
35	6L5-45631-00	CLUTCH, DOG CRABOT	1			

FIG. 18 LOWER CASING & DRIVE 2 BOITIER D'HELICE TRANSMISSION2



REF. NO.	PART NO. N° PIECES	DESCRIPTION DESCRIPTION	BEG1		REMARKS REMARQUES
1	6EG-44361-00	TUBE, WATER 1 TUBE D'EAU 1	1		S(17.0") S(17.0")
	6EG-44361-10	TUBE, WATER 1 TUBE D'EAU 1	1		L(22.0") L(22.0")
2	6EE-G4365-00	DAMPER, WATER SEAL 1 JOINT, TUBE D'EAU 1	1		
3	6L5-45251-03	ANODE ANODE	1		
4	95895-06012	BOLT, FLANGE BOULON	1		
5	92990-06300	WASHER, INTERNAL TOOTH RONDELLE, DENTURE INTERNE	1		
6	93604-12M07	PIN, DOWEL CLAVETTE	2		
7	97595-06530	BOLT, WITH WASHER VIS HEXAGONAL AVC RONDELLE	3		S(17.0") S(17.0")
8	6EE-G5987-00	SPACER 1 ENTRETOISE 1	1		
9	90201-13198	WASHER, PLATE RONDELLE, PLATE	1		
10	6EE-G5616-00	NUT, PROPELLER CONE, HELICE	1		
11	91490-25030	PIN, COTTER GOUPILLE	1		
12	90201-08M54	WASHER, PLATE RONDELLE, PLATE	1		
13	6L5-45949-00	PROPELLER (3X7-1/4"X5"-BS) HELICE (3X7-1/4"X5"-BS)	1		UR UR
	6L5-45943-00	PROPELLER (3X7-1/4"X6"-BS) HELICE (3X7-1/4"X6"-BS)	1		UR UR
14	6EG-G5211-00-8D	EXTENSION EXTENSION	1		L(22.0") L(22.0")
15	6L5-45318-00	BUSHING, DRIVE SHAFT DOUILLE, ARBRE MOTEUR	1		L(22.0") L(22.0")
16	90101-06M18	BOLT BOULON	3		L(22.0") L(22.0")
17	92990-06600	WASHER, PLATE RONDELLE, PLATE	3		L(22.0") L(22.0")
18	93420-22M03	CIRCLIP CIRCLIP, TYPE S	1		L(22.0") L(22.0")
19	93604-12M07	PIN, DOWEL CLAVETTE	2		L(22.0") L(22.0")

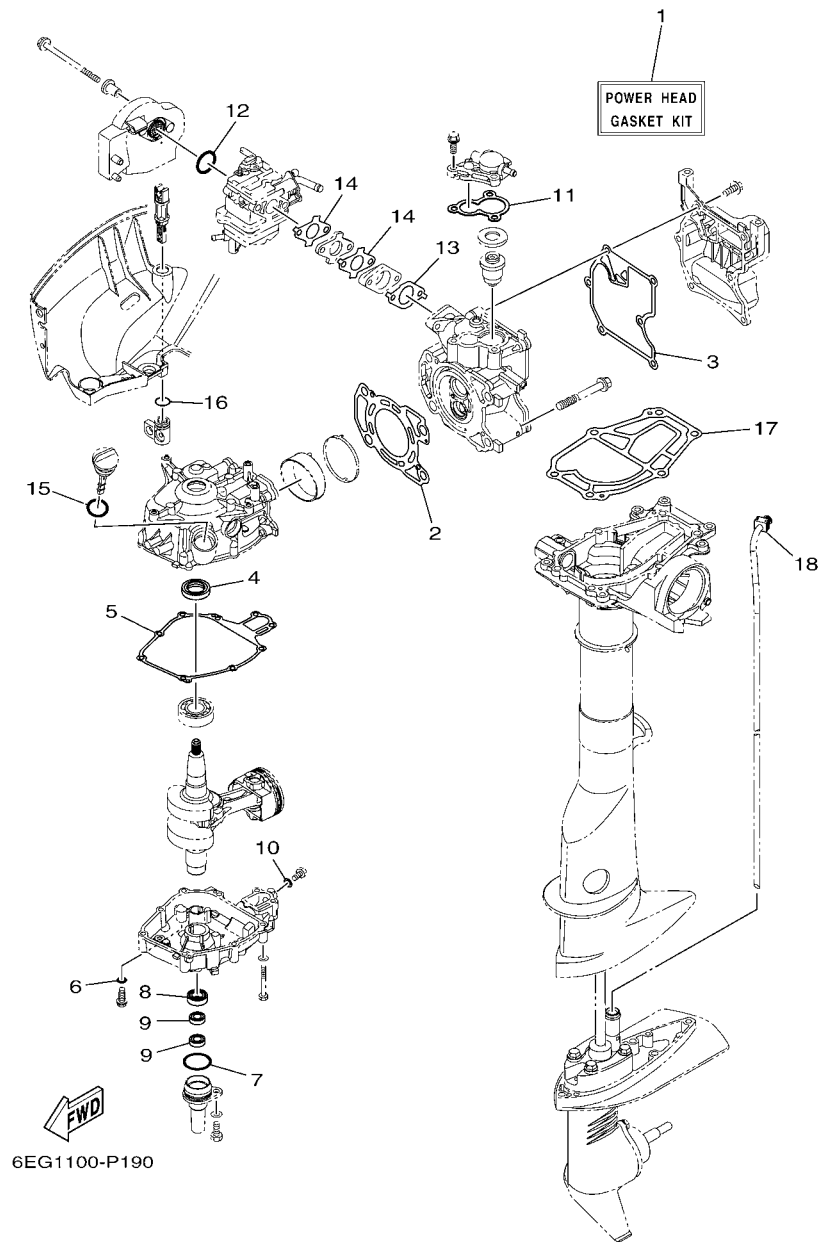

6EG1100-P190

FIG. 19 REPAIR KIT 1

KITS DE REPARATION 1

REF. NO.	PART NO. N° PIECES	DESCRIPTION DESCRIPTION	6EG1			REMARKS REMARQUES
1	6EG-W0001-00	POWER HEAD GASKET KIT POCHETTE DE JINTS TETE MOTRICE	1			
2	6EG-E1181-00	.GASKET, CYLINDER HEAD 1 .JOINT, DE CULASSE 1	1			
3	6EG-E1193-00	.GASKET, HEAD COVER 1 .JOINT, COUVERCLE DE CULASSE 1	1			
4	93102-20814	.OIL SEAL .JOINT SPY	1			
5	6EG-11351-00	.GASKET, CYLINDER .JOINT, D'EMBASE	1			
6	90201-08818	.WASHER, PLATE .RONDELLE, PLATE	1			
7	93210-35803	.O-RING .JOINT TORIQUE	1			
8	93102-20814	.OIL SEAL .JOINT SPY	1			
9	93102-09800	.OIL SEAL .JOINT SPY	2			
10	90430-08143	.GASKET .JOINT	1			
11	67D-12414-A0	.GASKET, COVER .JOINT, COUVERCLE	1			
12	93210-20801	.O-RING .JOINT TORIQUE	1			
13	6EG-E3645-00	.GASKET, MANIFOLD 1 .JOINT, TUBULURE 1	1			
14	6EG-E3646-00	.GASKET, MANIFOLD 2 .JOINT, TUBULURE 2	2			
15	93210-24800	.O-RING .JOINT TORIQUE	1			
16	93210-128F6	.O-RING .JOINT TORIQUE	1			
17	6EG-G5113-00	.GASKET, UPPER CASING .JOINT, TUBE D'ARBRE	1			
18	6EE-G4365-00	.DAMPER, WATER SEAL 1 .JOINT, TUBE D'EAU 1	1			

1
**CARBURETOR
 REPAIR KIT**

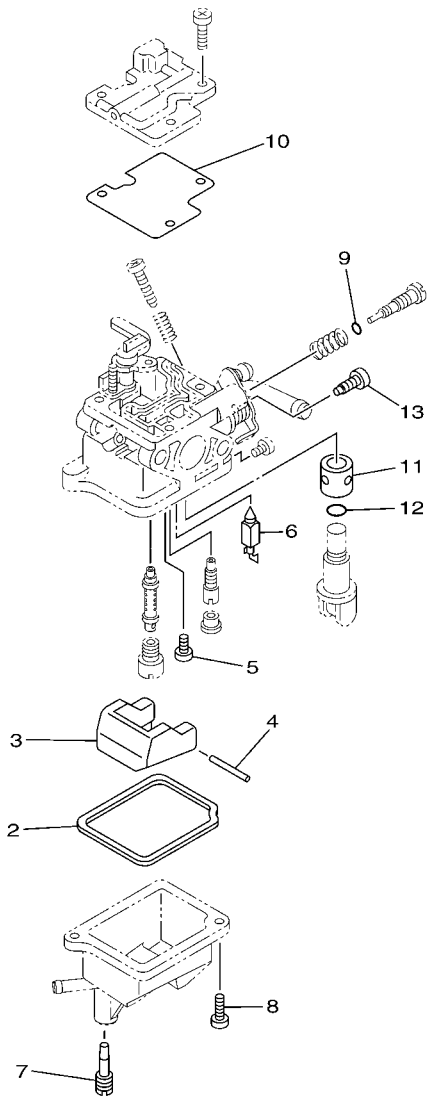

6EG1100-P200

FIG. 20 REPAIR KIT 2

KITS DE REPARATION 2

REF. NO.	PART NO. N° PIECES	DESCRIPTION DESCRIPTION	6EG1				REMARKS REMARQUES
1	69M-W0093-00	CARBURETOR REPAIR KIT KIT DE REPARATION CARBURATEUR	1				
2	69M-14984-00	.GASKET, FLOAT CHAMBER .JOINT, CUVE DE FLOTTEUR	1				
3	69M-14385-00	.FLOAT .FLOTTEUR	1				
4	6A1-14386-00	.PIN, FLOAT .AXE, FLOTTEUR	1				
5	98580-03005	.SCREW, PAN HEAD .VIS	1				
6	62Y-14392-00	.VALVE, NEEDLE .POINTEAU	1				
7	69M-14991-00	.SCREW .VIS	1				
8	98580-04010	.SCREW, PAN HEAD .VIS	2				
9	2T4-14397-00	.O-RING .JOINT TORIQUE	1				
10	69M-14536-00	.GASKET .JOINT	1				
11	69M-24523-00	.VALVE .SOUPAPE	1				
12	69M-24533-00	.O-RING .JOINT TORIQUE	1				
13	69M-24535-00	.SCREW, LEVER FITTING .VIS, FIXATION DE LEVIER	1				

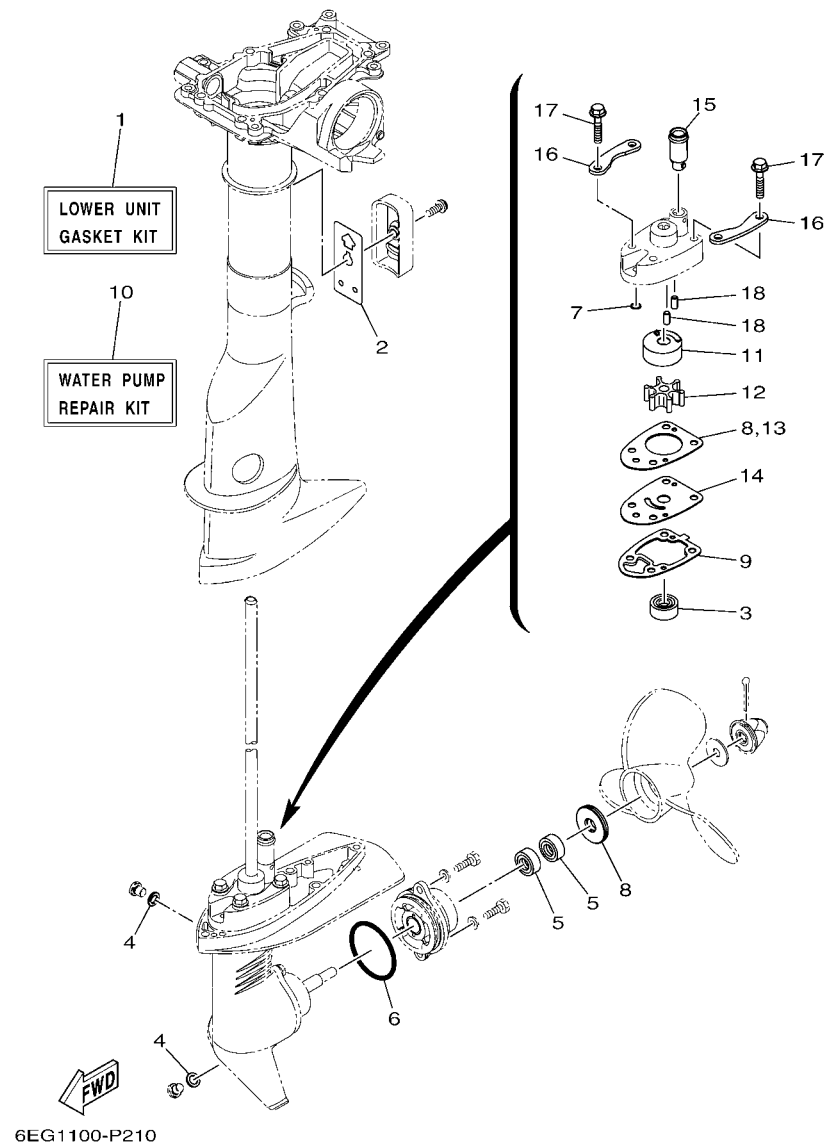

FIG. 21 REPAIR KIT 3

KITS DE PEPARATION 3

REF. NO.	PART NO. N° PIECES	DESCRIPTION DESCRIPTION	6EG1			REMARKS REMARQUES
1	6EG-W0001-20	LOWER UNIT GASKET KIT POCHETTE DE JOINTS EMBASE	1			
2	6EG-G5115-00	.GASKET, UPPER CASING .JOINT, TUBE D'ARBRE	1			
3	93103-09800	.OIL SEAL .JOINT SPY	1			
4	90430-08020	.GASKET .JOINT	2			
5	93101-13800	.OIL SEAL .JOINT SPY	2			
6	93210-48800	.O-RING .JOINT TORIQUE	1			
7	93210-05001	.O-RING .JOINT TORIQUE	1			
8	6EG-G4315-00	.GASKET, WATER PUMP .JOINT, POMPE A EAU	1			
9	6EG-G5315-00	.PACKING, LOWER CASING .JOINT, BOITIER D'HELICE	1			
10	6EG-W0078-00	WATER PUMP REPAIR KIT KIT DE REPARATION DE LA POMPE	1			
11	6EG-G4322-00	.INSERT, CARTRIDGE .CUVETTE	1			
12	6L5-44352-00	.IMPELLER .TURBINE	1			
13	6EG-G4315-00	.GASKET, WATER PUMP .JOINT, POMPE A EAU	1			
14	6EG-G4323-00	.OUTER PLATE, CARTRIDGE .PLAQUE EXTERIEURE	1			
15	6EE-G4366-00	.DAMPER, WATER SEAL 2 .JOINT, TUBE D'EAU 2	1			
16	6EG-G4328-00	.PLATE .PLAQUETTE	2			
17	97595-06535	.BOLT, WITH WASHER .VIS HEXAGONAL AVC RONDELLE	4			
18	93604-12M07	.PIN, DOWEL .CLAVETTE	2			

NUMERICAL INDEX
INDEX NUMERIQUE

PART NO. N° PIECES	REF. NO.	PART NO. N° PIECES	REF. NO.	PART NO. N° PIECES	REF. NO.	PART NO. N° PIECES	REF. NO.	PART NO. N° PIECES	REF. NO.	PART NO. N° PIECES	REF. NO.
6G8-11325-00	1 - 3	6G1-15755-00	10 - 10	6BX-82370-00	11 - 10	6EG-E4497-00	13 - 30	6EG-G2177-00	13 - 11	6EG-G4311-00	17 - 14
	3 - 14	63V-15764-00	10 - 2	682-82556-00	11 - 12	6EG-E5111-00-1S	5 - 7	6EE-G2181-00	13 - 5	6EG-G4315-00	17 - 19
6EG-11351-00	5 - 8	6G1-15779-00	10 - 11	65W-82575-01	11 - 11	6EG-E5316-00	12 - 10	6EE-G2182-00	13 - 7		21 - 8
	19 - 5	69M-15793-00	10 - 8	689-8257Y-00	11 - 13	6EG-E5362-00	5 - 24	6EE-G2188-00	13 - 6		21 - 13
676-11372-00	3 - 4	67D-21757-00	9 - 9	69M-85640-00	11 - 2	6EG-E5396-00-CA	5 - 14	6EG-G2529-00	15 - 30	6EG-G4322-00	17 - 15
6EG-11410-00	4 - 1	6L5-24251-00	1 - 5	69M-85650-00	11 - 1	6EG-E5710-00	10 - 1	6EG-G2537-00	15 - 14		21 - 11
7NJ-12117-00	6 - 7		9 - 14	6EG-E1111-00-1S	3 - 2	69M-E5714-00	10 - 3	6EG-G2538-00	15 - 15	6EG-G4323-00	17 - 20
67D-12157-00	6 - 12	69M-24523-00	8 - 23	6EE-E1133-10	3 - 3	6EG-E5751-00	10 - 9	6EE-G2561-00	15 - 31		21 - 14
69M-12411-01	1 - 2		20 - 11	6EG-E1181-00	3 - 7	6EG-E5789-00	10 - 12	6EG-G2610-00	2 - 1	6EG-G4328-00	17 - 23
	3 - 11	69M-24524-00	8 - 22		19 - 2	6EG-E5795-00	2 - 4	6EG-G2613-00	2 - 3		21 - 16
688-12412-00	3 - 12	69M-24533-00	8 - 24	6EG-E1191-00	3 - 8	6EG-F4111-00	9 - 1	6EG-G261A-00	2 - 2	6EE-G4365-00	18 - 2
67D-12414-A0	1 - 4		20 - 12	6EG-E1193-00	3 - 9	6EG-F4181-00	9 - 18	6EG-G2675-00	2 - 5		19 - 18
	3 - 16	69M-24535-00	8 - 25		19 - 3	6EG-F4182-00	10 - 14	6EG-G2677-00	2 - 6	6EE-G4366-00	17 - 22
	19 - 11		20 - 13	6EG-E1311-00-1S	5 - 1	6EG-F4191-00	9 - 17	6EG-G2697-00	2 - 7		21 - 15
6EG-1246L-00	5 - 6	68D-24610-10	9 - 2	69M-E1603-01	4 - 6	6EG-F4311-00	9 - 15	6EE-G2698-40	2 - 10	6EG-G4532-00	12 - 17
62Y-14212-00	8 - 21	68D-24612-00	9 - 3	69M-E1604-01	4 - 6	6EG-F4375-00	9 - 11	6EE-G2698-50	2 - 11	6EG-G5111-00-8D	16 - 1
6EG-14301-00	8 - 1	69M-24633-00	9 - 8	69M-E1605-01	4 - 6	6EE-F4377-00	16 - 2	6EG-G2711-00	12 - 1	6EG-G5113-00	16 - 6
69W-14321-00	8 - 20	624-24634-00	9 - 7	6EG-E1631-00	4 - 5	6EG-F4554-00	9 - 19	6EG-G2712-00	12 - 6		19 - 17
69M-14323-20	8 - 15	6EG-24641-00	9 - 10	6EG-E1633-00	4 - 7	6EG-F4575-00	9 - 21	6EG-G2724-00	12 - 8	6EG-G5115-00	16 - 11
62Y-14334-00	8 - 17	6H1-41237-00	13 - 37	6EG-E1635-00	4 - 5	6EG-F4591-00	12 - 18	6EG-G2727-00	12 - 7		21 - 2
69M-14341-00	8 - 4	682-41237-50	13 - 36	6EG-E1636-00	4 - 5	6EG-F6301-00	13 - 23	6EG-G2731-00	16 - 13	6EG-G5151-00	16 - 10
69M-14342-68	8 - 5	661-41262-02	13 - 29	6EG-E1650-00	4 - 3	6EG-F6330-00	7 - 13	6EG-G2768-00	12 - 12	6EG-G5152-00	16 - 4
6EG-14343-3A	8 - 3	6G1-42125-01	13 - 20	7DX-E1654-00	4 - 4	6EE-F8100-00	9 - 27	6EG-G2774-00	12 - 4	6EG-G5211-00-8D	18 - 14
6EG-14381-00	8 - 7	6BX-42129-00	13 - 2	6EG-E2111-00	6 - 2	6EG-F8199-70-D0	9 - 28	6EF-G2794-40	13 - 39	6EG-G5300-00-8D	17 - 1
69M-14385-00	8 - 9	69M-42528-00	15 - 29	6EG-E2113-00	6 - 5	6EG-F8199-70-E0	9 - 28	6EF-G2794-50	13 - 40	6EG-G5300-10-8D	17 - 1
	20 - 3	6EG-42628-00	12 - 2	7CN-E2118-00	6 - 8	6EG-F8199-70-F0	9 - 28	6EG-G2823-00	12 - 15	6EG-G5311-00-8D	17 - 2
6A1-14386-00	8 - 10	6EG-42629-00	12 - 3	6EG-E2119-00	6 - 4	6EG-F8199-70-G0	9 - 28	6EG-G3111-00-8D	15 - 1	6EG-G5315-00	17 - 21
	20 - 4	6L5-42647-00	12 - 14	6EG-E2121-00	6 - 3	6EG-F8199-70-H0	9 - 28	6EE-G3118-00	15 - 3		21 - 9
62Y-14392-00	8 - 12	648-43114-01	15 - 5	6EE-E2151-00	6 - 9	6EG-F8199-70-S0	9 - 28	6EG-G3164-00	15 - 25	6EG-G5361-00-8D	17 - 9
	20 - 6	6E0-43116-01	15 - 2	6EE-E2153-00	6 - 15	6EG-F8199-80-K0	9 - 29	6EG-G3166-00	15 - 26	6EG-G5511-00	17 - 26
2T4-14397-00	8 - 16	69M-44143-00	14 - 10	6EG-E2154-00	6 - 14	6EG-F8199-80-L0	9 - 29	6EG-G3180-00	15 - 19	6EG-G5511-10	17 - 26
	20 - 9	6L5-44352-00	17 - 16	6EG-E2155-00	6 - 13	6EG-F8199-80-M0	9 - 29	6EG-G3185-00	15 - 24	6EG-G5533-00	17 - 30
6EG-14440-00	7 - 2		21 - 12	6EE-E2158-00	6 - 11	6EG-F8199-80-N0	9 - 29	6EG-G3186-00	15 - 21	6EG-G5611-00	17 - 32
69M-14527-00	8 - 18	6EG-44361-00	18 - 1	6EE-E2165-00	6 - 10	6EG-F8199-80-P0	9 - 29	6EG-G3188-00	15 - 20	6EE-G5616-00	18 - 10
69M-14536-00	8 - 19	6EG-44361-10	18 - 1	6EG-E2170-00	6 - 1	6EG-F8199-80-R0	9 - 29	6EG-G3311-00-8D	15 - 12	6EG-G5635-00	17 - 34
	20 - 10	69M-44557-00	15 - 35	6EG-E2413-00-1S	3 - 13	6EG-G1211-00	13 - 28	6EG-G3312-00-8D	15 - 13	6EE-G5987-00	18 - 8
6EG-14664-00	5 - 5	647-45151-01	12 - 9	6EG-E2483-00	7 - 6	6EG-G1283-00	13 - 26	6EG-G3351-00	15 - 34	6EE-H1994-40	9 - 25
69M-14966-00	8 - 6		16 - 3	6EG-E3102-00	5 - 22	6EG-G1284-00	13 - 31	6EG-G3679-00	15 - 18	6EE-H1994-50	9 - 26
69M-14984-00	8 - 8	6L5-45251-03	1 - 6	6EG-E316F-00	7 - 7	6EE-G1638-00	13 - 25	6EG-G3691-00	15 - 39	6EG-W0001-00	19 - 1
	20 - 2		18 - 3	6EG-E3437-60	9 - 24	6EG-G2111-00-8D	13 - 1	6EG-G4111-00	14 - 1	6EG-W0001-20	21 - 1
69M-14991-00	8 - 13	6L5-45316-09	17 - 3	6EG-E3641-00	7 - 12	6EG-G2119-00	13 - 10	6EG-G4121-00	14 - 6	6EG-W0078-00	1 - 9
	20 - 7	6L5-45317-09	17 - 4	6EG-E3645-00	7 - 9	6EE-G2126-00	13 - 21	68D-G4122-01	14 - 5		21 - 10
3Y6-15361-00	5 - 4	6L5-45318-00	18 - 15		19 - 13	6EE-G2131-00	13 - 8	6EG-G4126-00	14 - 7	69M-W0093-00	20 - 1
6BX-15705-00	10 - 6	6L5-45551-00	17 - 28	6EG-E3646-00	7 - 10	6EG-G2137-00	13 - 12	6EG-G4144-00	14 - 16	6EG-WE090-00-1S	3 - 1
67D-15713-00	10 - 5	6L5-45560-00	17 - 31		19 - 14	6EG-G2138-00	13 - 17	6EG-G4144-10	14 - 16	90101-06062	15 - 36
69M-15723-00	11 - 6	6L5-45631-00	17 - 35	6EG-E3647-00	7 - 11	6EE-G2159-00	13 - 18	6NO-G4145-10	14 - 13	90101-06M18	18 - 16
69M-15735-00	10 - 7	6L5-45943-00	18 - 13	6EG-E4148-00	7 - 1	6EE-G2171-00	13 - 3	6NO-G4146-10	14 - 14	90101-08M07	15 - 6
69M-15741-00	10 - 4	6L5-45949-00	18 - 13	6EG-E4427-60	2 - 9	6EE-G2172-00	13 - 4	6EG-G4191-00	2 - 8	90105-06039	3 - 10

NUMERICAL INDEX
INDEX NUMERIQUE

PART NO. N° PIECES	REF. NO.	PART NO. N° PIECES	REF. NO.	PART NO. N° PIECES	REF. NO.	PART NO. N° PIECES	REF. NO.	PART NO. N° PIECES	REF. NO.	PART NO. N° PIECES	REF. NO.
90105-06M24	11 - 7	90464-16003	11 - 15	93210-35803	5 - 15	98580-03005	20 - 5				
90105-08M36	3 - 5	90467-07M12	17 - 27		19 - 7	98580-04010	8 - 14				
90105-08M76	5 - 12	90467-09M09	3 - 20	93210-48800	17 - 11		20 - 8				
90119-06098	9 - 13		7 - 8		21 - 6	99001-06600	17 - 29				
90119-06M17	12 - 13	90467-11M08	9 - 23	93306-272Y2	5 - 3	99080-04600	15 - 27				
90119-06MA2	3 - 17	90467-13M13	9 - 16	93316-003Y0	17 - 6						
90119-06ME0	14 - 15	90468-100A0	9 - 6	93420-22M03	18 - 18						
90152-05014	13 - 15	90480-25161	11 - 8	93450-13811	4 - 8						
90157-05013	12 - 5	90501-10064	17 - 33	93505-16024	14 - 3						
90159-05M12	9 - 22	90501-100A5	9 - 4	93604-07M13	17 - 17						
	16 - 5	90501-12802	14 - 4	93604-12M07	3 - 6						
90159-06M11	16 - 12	90501-12803	15 - 33		5 - 11						
90167-03M02	12 - 16	90501-23215	13 - 13		16 - 7						
90170-10M33	11 - 4	91490-16010	13 - 22		17 - 25						
90179-11800	7 - 14		14 - 12		18 - 6						
90201-06040	15 - 37	91490-25030	18 - 11		18 - 19						
90201-06M62	13 - 35	91609-25014	14 - 17		21 - 18						
90201-08818	5 - 13	91690-20010	15 - 23	93700-06M03	15 - 28						
	19 - 6	92903-06600	5 - 10		16 - 9						
90201-08M54	18 - 12	92990-04200	9 - 5	94702-00372	1 - 8						
90201-105A2	11 - 5	92990-05600	14 - 11		3 - 21						
90201-10M02	13 - 14	92990-06300	18 - 5	95380-05600	13 - 38						
90201-13198	18 - 9	92990-06600	18 - 17	95380-08600	15 - 10						
90201-168G9	6 - 6	92990-08200	15 - 9	95380-08700	15 - 11						
90201-23008	4 - 2	92995-05600	14 - 9	95780-06300	15 - 38						
90202-08004	15 - 8	92995-06600	15 - 17	95817-06012	5 - 23						
90202-08022	15 - 7		16 - 15	95895-06012	18 - 4						
90243-04M01	15 - 4		17 - 13	97013-06045	5 - 9						
90266-04M05	15 - 32	92995-08600	5 - 19	97075-06030	15 - 16						
90280-04M06	11 - 3	93101-13800	17 - 10	97075-08025	13 - 9						
90340-08002	17 - 7		21 - 5	97095-05012	14 - 8						
90386-08032	13 - 16	93102-09800	5 - 17	97095-06016	17 - 12						
	15 - 22		19 - 9	97095-06025	16 - 14						
90387-06076	7 - 5	93102-20814	5 - 2	97095-08014	5 - 20						
90387-06176	9 - 12		5 - 16	97095-08020	5 - 18						
90387-06252	13 - 27		19 - 4	97575-06535	16 - 8						
90387-068N9	12 - 11		19 - 8	97595-06512	11 - 9						
90387-06M24	13 - 32	93103-09800	17 - 5	97595-06520	13 - 34						
90430-08020	1 - 7		21 - 3	97595-06530	18 - 7						
	17 - 8	93210-05001	17 - 18	97595-06535	13 - 33						
	21 - 4		21 - 7		17 - 24						
90430-08143	1 - 1	93210-09811	14 - 2		21 - 17						
	5 - 21	93210-128F6	9 - 20	97595-06560	10 - 13						
	19 - 10		19 - 16	97595-06585	7 - 4						
90445-09808	3 - 18	93210-20801	7 - 3	97880-05025	3 - 15						
90446-06M90	11 - 14		19 - 12	97885-05012	13 - 19						
90464-07M20	13 - 24	93210-24800	5 - 25	97890-04007	8 - 2						
90464-09013	3 - 19		19 - 15	98580-03005	8 - 11						