

**PARTS
CATALOGUE
CATALOGUE
DE PIÈCES DÉTACHÉES**

F2.5AMH'03(69M1)

2B69M-300F1

YAMAHA
GENUINE
Parts & Accessories

2006/9/1

NEWS NO.	DATE	COMMENT
PE0-OM-020002	OCT.,02,2002	COR:FIG.16 LOWER CASING.DRIVE 1 ILLUSTRATION CORRECTION
PE0-OM-060012	Aug.,22,2006	COR:FIG.17 PROPELLER PART NAME CORRECTION

FOREWORD

This Parts Catalogue is related to the parts for the model(s) in the below frame. When you are ordering replacement parts, please refer to this Parts Catalogue and quote both part numbers and part names correctly.

F2.5AMH'03(69M1)

1. Modifications or additions which have been made after issue of the Parts Catalogue will be announced in the Yamaha Parts News.
It is advisable that you make necessary corrections to the Parts Catalogue according to the Yamaha Parts News.

2. Abbreviations

The Following abbreviations are used in this Parts Catalogue.

“UR” Use specified parts number.

“UN” Use as many as needed.

“AP” Alternate Parts

“LM” Local Made

(Parts need to be ordered locally)

“O/S” Over Size

3. Parts, which are to be supplied in an assembly, are listed with a dot(.) in front of the part name as shown below.

EXAMPLE

CARBURETOR ASSY

.JET, PILOT

.NOZZLE, MAIN

4. Number of component for assembly

The numeral appearing to the right of each component part indicates the quantity of parts for each assembly unit.

EXAMPLE

PART NO.	DESCRIPTION	□	田	田	田	REMARKS
6E0-85500-70	C.D.I. MAGNETO ASSY	1				
6E0-85550-70	.ROTOR ASSY	1				
6E0-15723-00-94..	PULLY, STARTER	1				

5. Quantity Column Information

NAME for Q'TY COLUMN	APPLICABLE MODEL
F2.5	F2.5AMH

6. Applicable Starting Serial No. and Color Code

1) Engine Starting Serial No.

F2.5AMH S/L 69M : 1000101

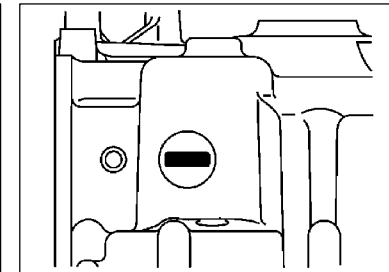
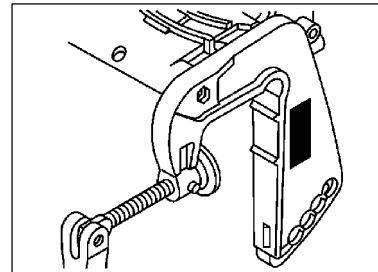

2) Color Code

Color Code	Color Name	Abbreviation
004D	DARK BLUISH GRAY METALLIC 2	DBNM2

7. Note that the illustrations for reference in finding parts numbers, not to be used for assembling. When assembling, please use the applicable service manual.

8. The asterisk (*) before a reference number indicates modification items after the first edition.

CONTENTS

TOP COWLING	A4
CYLINDER. CRANKCASE 1	A5
CRANKSHAFT. PISTON	A6
CYLINDER. CRANKCASE 2	A7
VALVE	B2
INTAKE	B3
CARBURETOR	B4
FUEL	B5
STARTER	B6
GENERATOR	B7
BOTTOM COWLING	C1
STEERING	C2
CONTROL	C3
BRACKET	C4
UPPER CASING	C6
LOWER CASING. DRIVE 1	C7
LOWER CASING. DRIVE 2	D2
REPAIR KIT 1	D3
REPAIR KIT 2	D4
REPAIR KIT 3	D5
INDEX	
NUMERICAL INDEX	D6

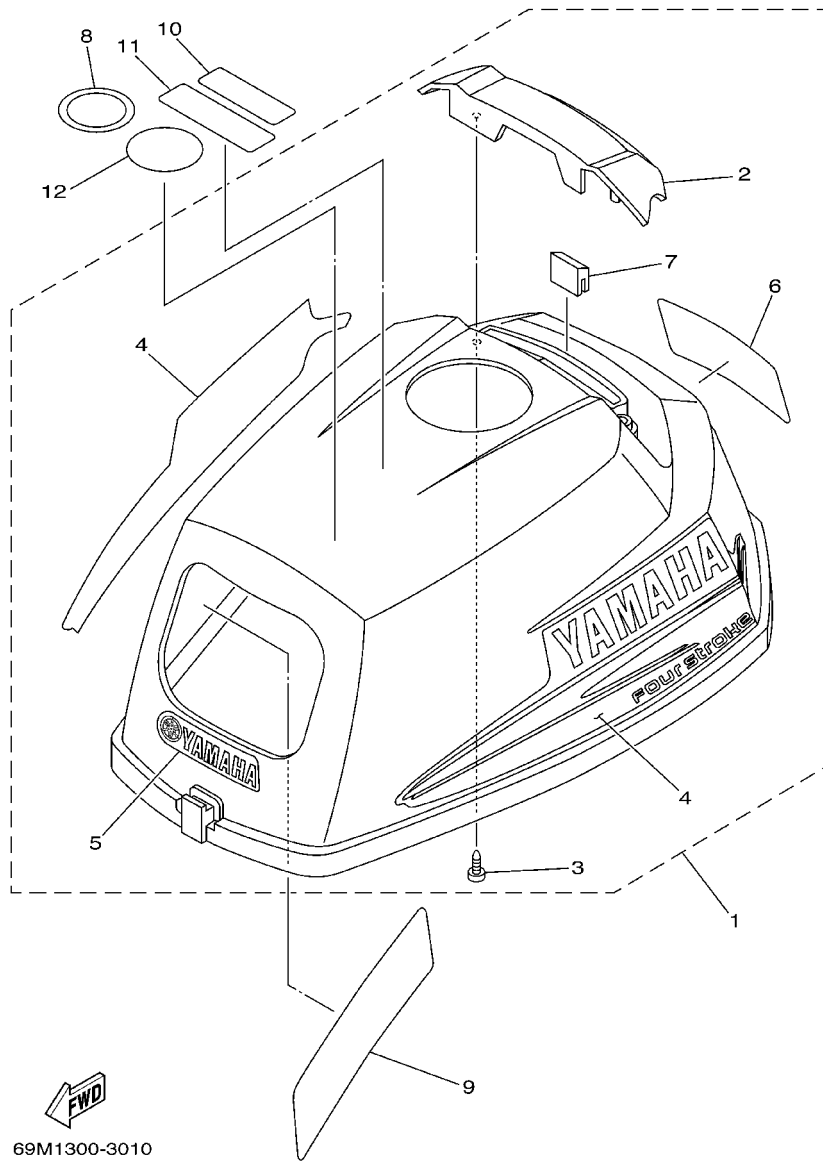
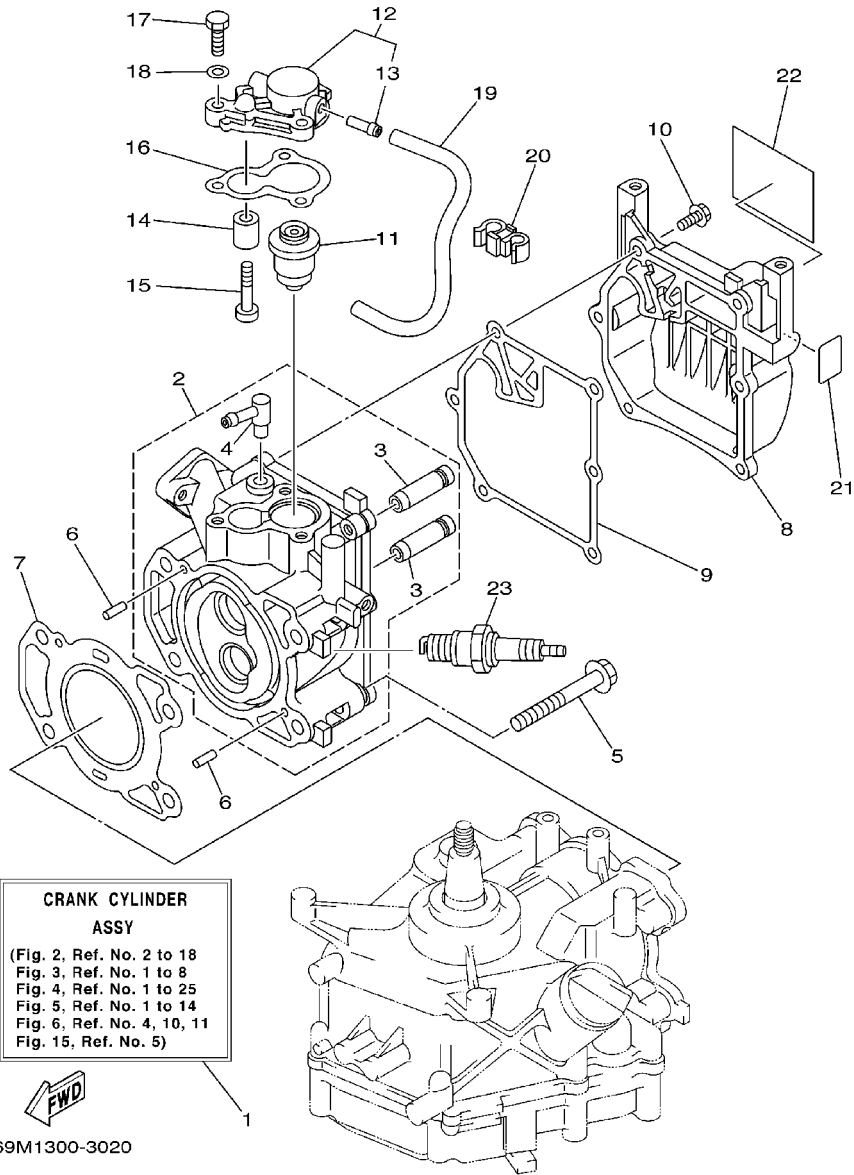

FIG. 1 TOP COWLING

CAPOT SUPERIEUR

REF. NO.	PART NO. NO. PIECES	DESCRIPTION DESCRIPTION	F2.5				REMARKS REMARQUES
1	69M-G2610-10-4D	TOP COWLING ASSY CAPOT (ENS.)	1				
2	69M-G2613-00	.MOLDING, AIR DUCT .MANCHON A AIR	1				
3	97780-40012	.SCREW, TAPPING .VIS, TETE BOMBEE	2				
4	69M-WG070-00	.GRAPHIC SET .JEU DIEMBLEMES	1				
5	69M-G2677-00	.GRAPHIC, FRONT .ADHESIF, AVANT	1				
6	69M-G2678-10	.GRAPHIC, REAR .ADHESIF, ARRIERE	1				
7	69M-42662-00	.DAMPER .AMORTISSEUR	1				
8	67F-13434-02	LABEL, CAUTION ETIQUETTE, ATTENTION	1				
9	69M-14427-60	LABEL, INSTRUCTION ETIQUETTE, INSTRUCTION	1				
10	6A1-2415A-41	LABEL, CAUTION ETIQUETTE, RECOMMANDATION	1				
11	6A1-2415A-51	LABEL, CAUTION ETIQUETTE, RECOMMANDATION	1				
12	6G8-2415E-00	LABEL, CAUTION EMBLEME, RECOMMANDATION	1				

FIG. 2 CYLINDER. CRANKCASE 1 CYLINDRE. CARTER 1



REF. NO.	PART NO. NO. PIECES	DESCRIPTION DESCRIPTION	F2.5				REMARKS REMARQUES
1	69M-WE090-00-4D	CRANK CYLINDER ASSY EMBIELLAGE CYLINDRE (ENS.)	1				
2	69M-E1111-00-94	HEAD, CYLINDER 1 CULASSE	1				
3	67D-11133-10	.GUIDE, INTAKE VALVE .GUIDE, SOUP D'ADM	2				
4	676-11372-00	.NIPPLE, HOSE .RACCORD, TUYAU	1				
5	90105-08M36	BOLT, FLANGE BOULON	4				
6	93604-12M07	PIN, DOWEL CLAVETTE	2				
7	69M-11181-00	GASKET, CYLINDER HEAD 1 JOINT, DE CULASSE 1	1				
8	69M-E1191-00-94	COVER, CYLINDER HEAD 1 COUVERCLE, CULASSE 1	1				
9	69M-11193-A0	GASKET, HEAD COVER 1 JOINT, COUVERCLE DE CULASSE 1	1				
10	90105-06M14	BOLT FLANGE BOULON	6				
11	69M-12411-00	THERMOSTAT THERMOSTAT	1				
12	69M-E2413-00-9M	COVER, THERMOSTAT COUVERCLE, THERMOSTAT	1				
13	650-24378-00	.PIPE, JOINT 4 .DURITE RACCORDEMENT 4	1				
14	68D-E1325-00	ANODE ANODE	1				
15	97880-05025	SCREW, PAN HEAD VIS, TETE TRONCONIQUE	1				
16	68D-E2414-A0	GASKET, COVER JOINT, COUVERCLE	1				
17	97095-06020	BOLT BOULON	3				
18	92995-06600	WASHER RONDELLE	3				
19	90445-09808	HOSE DURITE	1				
20	90464-09013	CLAMP BRIDE	1				
21	67D-42791-10	MARK 1 ETIQUETTE 1	1				
22	68D-E2138-60	MARK, CAUTION MAKER	1				
23	94702-00248	PLUG, SPARK (NGK BR6HS) BOUGIE D,ALLUMAGE (NGK BR6HS)	1				

FIG. 3 CRANKSHAFT. PISTON

VILEBREQUIN. PISTON

REF. NO.	PART NO. NO. PIECES	DESCRIPTION DESCRIPTION	F2,5				REMARKS REMARQUES
1	69M-11400-00	CRANKSHAFT ASSY VILEBREQUIN COMPLET	1				
2	90201-23008	WASHER, PLATE RONDELLE, PLATE	1				
3	69M-11650-00	CONNECTING ROD ASSY BIELLE COMPLETE	1				
4	7FK-11654-00	.BOLT, CONNECTING ROD .BOULON, BIELLE	2				
5	69M-E1631-00-96	PISTON (STD) PISTON (STD)	1				
6	69M-E1603-00	PISTON RING SET (STD) JUE DE SEGMENTS (STD)	1				
7	69M-E1633-00	PIN, PISTON AXE, PISTON	1				
8	93450-13130	CIRCLIP CIRCLIP	2				

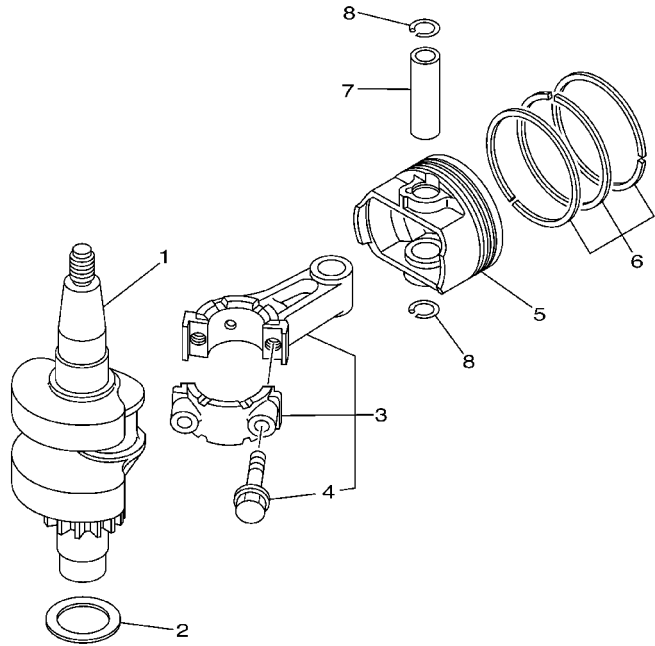

69M1010-3030

FIG. 4 CYLINDER. CRANKCASE 2 CYLINDRE. CARTER 2

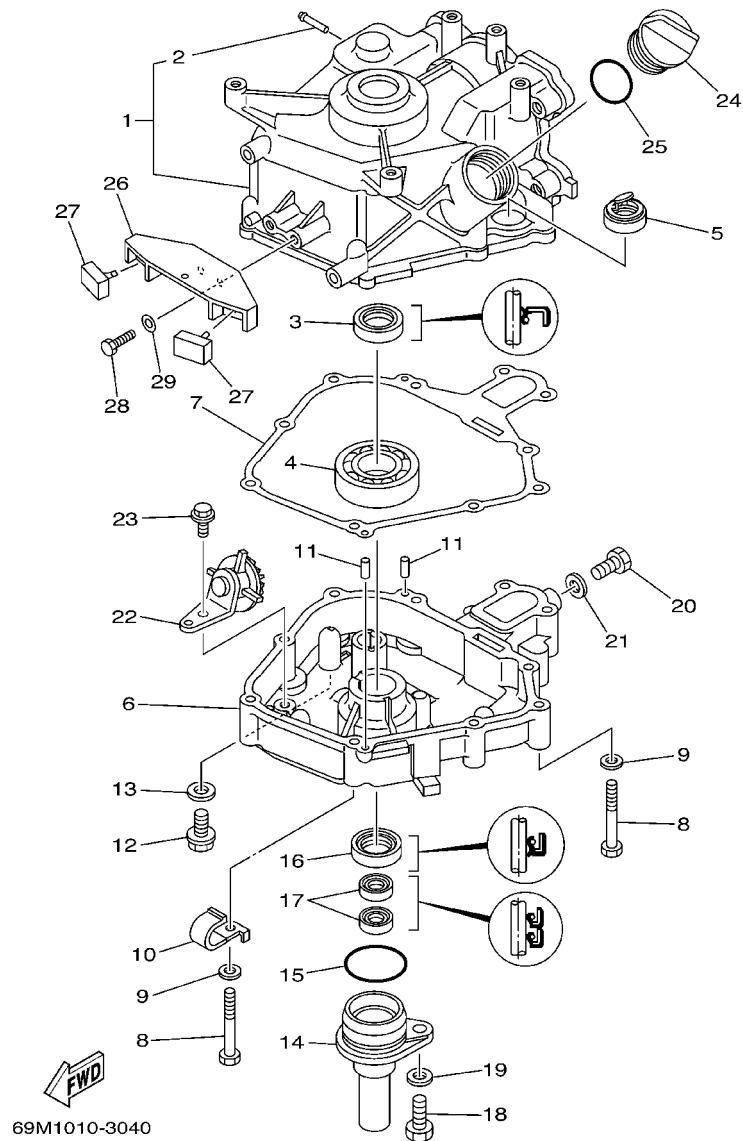

69M1010-3040

REF. NO.	PART NO. NO. PIECES	DESCRIPTION DESCRIPTION	F2.5				REMARKS REMARQUES
1	69M-E1311-00-94	CYLINDER 1 CYLINDRE 1	1				
2	6H1-14485-00	.PIPE, JOINT .DURITE	1				
3	93102-20108	OIL SEAL JOINT SPY	1				
4	93306-272Y2	BEARING ROULEMENT	1				
5	69M-15361-00	GAUGE, LEVEL JAUGE A HUILE	1				
6	69M-E5111-00-94	CRANKCASE 1 CARTER DE MOTEUR	1				
7	69M-11351-A0	GASKET, CYLINDER JOINT, D'EMBASE	1				
8	97013-06045	BOLT BOULON	10				
9	92903-06600	WASHER, PLATE RONDELLE, PLATE	10				
10	90465-08M99	CLAMP BRIDE	1				
11	93604-12M07	PIN, DOWEL CLAVETTE	2				
12	90105-08M76	BOLT, FLANGE BOULON	1				
13	90201-08818	WASHER, PLATE RONDELLE, PLATE	1				
14	69M-E5396-00-5B	HOUSING, OIL SEAL LOGEMENT DE JOINT SPY	1				
15	93210-35537	O-RING JOINT TORIQUE	1				
16	93102-20108	OIL SEAL JOINT SPY	1				
17	93102-09004	OIL SEAL JOINT SPY	2				
18	97095-08020	BOLT BOULON	1				
19	92995-08600	WASHER RONDELLE	1				
20	97095-08014	BOLT BOULON	1				
21	90430-08800	GASKET JOINT	1				
22	69M-E3102-00	GEAR UNIT ASSY PIGNON	1				
23	95817-06012	BOLT, FLANGE BOULON, A COLLERETTE	1				
24	69M-E5363-00	PLUG, OIL PLOT, HUILE	1				
25	93210-24M79	O-RING JOINT TORIQUE	1				
26	69M-G2743-00	BRACKET SUPPORT	1				
27	6G8-44532-00	STOPPER, UPPER MOUNT PLAQUETTE	2				

FIG. 4 CYLINDER. CRANKCASE 2 CYLINDRE. CARTER 2

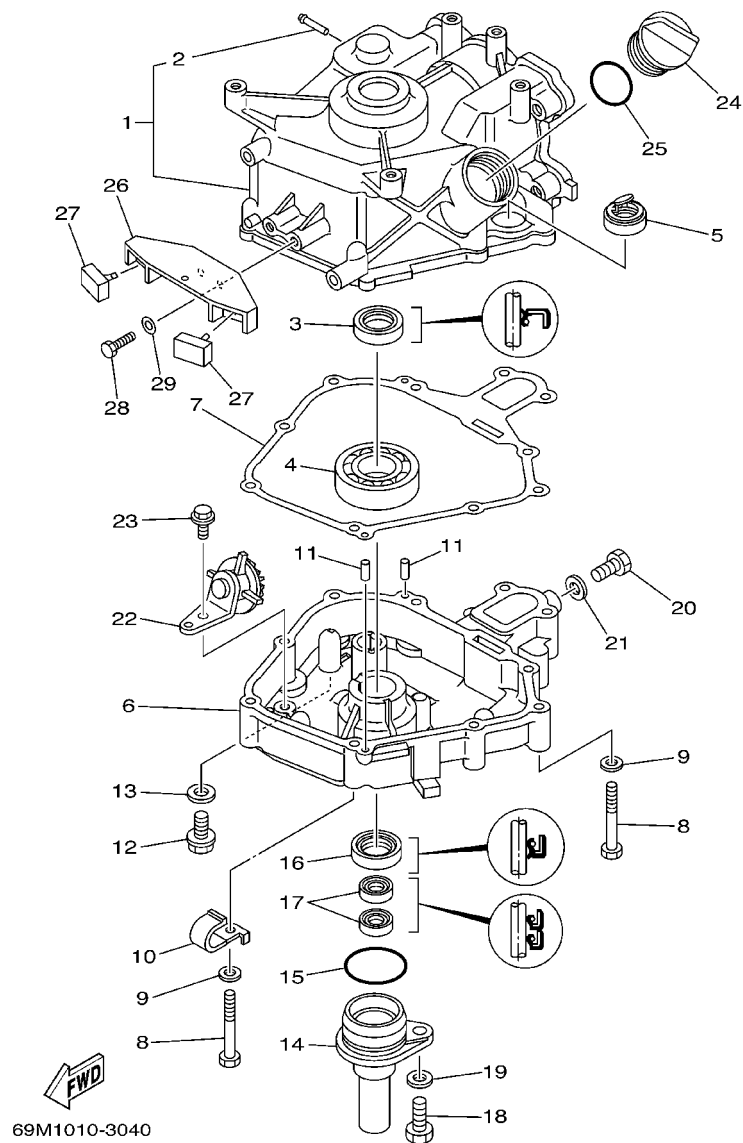

REF. NO.	PART NO. NO. PIECES	DESCRIPTION DESCRIPTION	F2.5			REMARKS REMARQUES
28	97095-06020	BOLT BOULON	2			
29	92995-06600	WASHER RONDELLE	2			

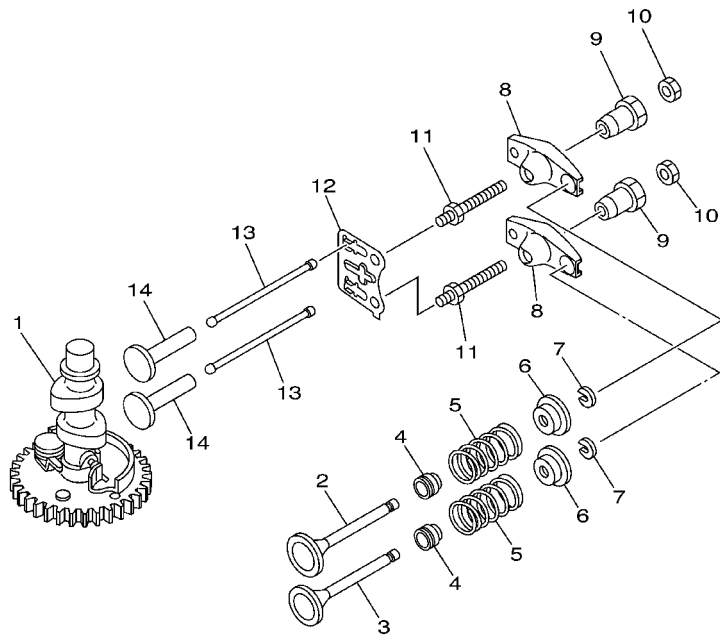

FIG. 5 VALVE

SOUPAPE

REF. NO.	PART NO. NO. PIECES	DESCRIPTION DESCRIPTION	F2.5				REMARKS REMARQUES
1	69M-12170-20	CAMSHAFT ASSY 1 ENS ARBRE A CAMES 1	1				
2	67D-12111-00	VALVE, INTAKE SOUPAPE, ADMISSION	1				
3	67D-12121-00	VALVE, EXHAUST SOUPAPE, ECHAPPEMENT	1				
4	51Y-12119-00	SEAL, VALVE STEM JOINT, QUEUE DE SOUPAPE	2				
5	68D-E2113-00	SPRING, VALVE INNER RESSORT DE SOUPAPE, INTERNE	2				
6	7NJ-12117-00	RETAINER, VALVE SPRING BUTEE DE RESSORT DE SOUPAPA	2				
7	7NJ-12118-00	COTTER, VALVE FRAISE, SOUPAPE	2				
8	67D-12151-00	ARM, VALVE ROCKER CULBUTEUR	2				
9	7FK-12165-00	PIVOT, ROCKER ARM PIVOT, CULBUTEUR	2				
10	7FK-12158-00	NUT, LOCK CONTRE-ECROU	2				
11	67D-12157-00	BOLT BOULON	2				
12	69M-E2155-00	GUIDE, PUSH ROD GUIDE, TIGE-POUSSOIR	1				
13	69M-12154-00	ROD, VALVE PUSH TIGE DE LEVE-SOUPAPE	2				
14	JA9-12153-00	LIFTER, VALVE LEVE-SOUPAPE	2				



69M1010-3050

FIG. 6 INTAKE

ADMISSION

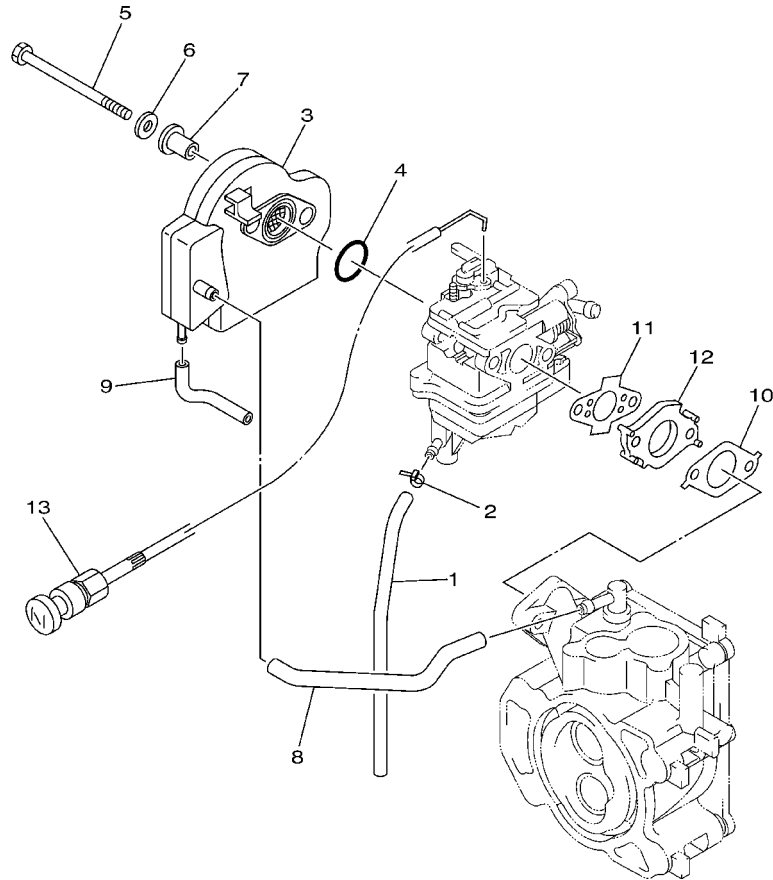

REF. NO.	PART NO. NO. PIECES	DESCRIPTION DESCRIPTION	F2.5				REMARKS REMARQUES
1	69M-E4148-00	PIPE DURITE	1				
2	90465-11M10	CLAMP BRIDE	1				
3	69M-14440-00	SILENCER ASSY, INTAKE SIENCIEUX D'ADMISSION	1				
4	93210-20M65	O-RING JOINT TORIQUE	1				
5	97095-06075	BOLT BOULON	2				
6	92995-06600	WASHER RONDELLE	2				
7	90387-063Y3	COLLAR COLLERETTE	2				
8	69M-E2483-00	PIPE 3 DURITE 3	1				
9	90445-07805	HOSE (L70) DURITE (L70)	1				
10	69M-E3645-A0	GASKET, MANIFOLD 1 JOINT, TUBULURE 1	1				
11	69M-E3646-A0	GASKET, MANIFOLD 2 JOINT, TUBULURE 2	1				
12	69M-E3647-00	GASKET, MANIFOLD 3 JOINT, TUBULURE 3	1				
13	69M-F6330-00	STARTER CABLE ASSY CABLE DE STARTER	1				



69M1010-3060

FIG. 7 CARBURETOR

CARBURATEUR

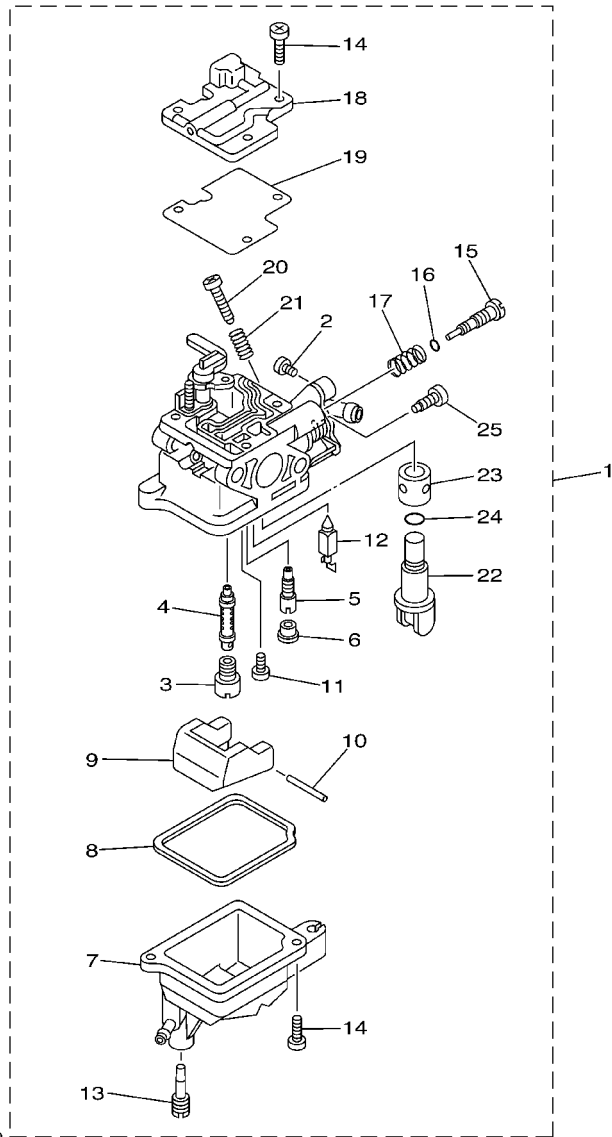

69M1010-3070

REF. NO.	PART NO. NO. PIECES	DESCRIPTION DESCRIPTION	F2,5	REMARKS REMARQUES
1	69M-14301-20	CARBURETOR ASSY 1 CARBURATEUR COMPLET 1	1	
2	97890-04007	.SCREW, PAN HEAD .VIS, CRUCIFORME	2	
3	69M-14343-31	.JET, MAIN (# 62) .GICLEUR, PRINCIPAL (# 62)	1	
4	69M-14341-00	.NOZZLE, MAIN .PUITS D'AIGUILLE	1	
5	69M-14342-68	.JET, PILOT (#37) .GICLEUR, RALENTI (#37)	1	
6	69M-14966-00	.BUSH .BAGUE	1	
7	69M-14381-00	.BODY, FLOAT CHAMBER .CORPS, CUVE DE FLOTTEUR	1	
8	69M-14984-00	.GASKET, FLOAT CHAMBER .JOINT, CUVE DE FLOTTEUR	1	
9	69M-14385-00	.FLOAT .FLOTTEUR	1	
10	6A1-14386-00	.PIN, FLOAT .AXE, FLOTTEUR	1	
11	98580-03005	.SCREW, PAN HEAD .VIS	1	
12	62Y-14392-00	.VALVE, NEEDLE .POINTEAU	1	
13	69M-14991-00	.SCREW .VIS	1	
14	98580-04010	.SCREW, PAN HEAD .VIS	5	
15	69M-14323-20	.SCREW, AIR ADJUSTING .VIS DE DOSEUR D'AIR	1	
16	2T4-14397-00	.O-RING .JOINT TORIQUE	1	
17	62Y-14334-00	.SPRING, AIR ADJUSTING .RESSORT, VIS DE DOSEUR D'AIR	1	
18	69M-14527-00	.PLATE .PLAQUE	1	
19	69M-14536-00	.GASKET .JOINT	1	
20	69W-14321-00	.SCREW, THROTTLE .VIS, ACCELERATEUR	1	
21	62Y-14212-00	.SPRING, PILOT ADJUSTING .RESSORT, VIS DE RALENTI	1	
22	69M-24524-00	.LEVER, COCK .LEVIER, ROBINET	1	
23	69M-24523-00	.VALVE .SOUPAPE	1	
24	69M-24533-00	.O-RING .JOINT TORIQUE	1	
25	69M-24535-00	.SCREW, LEVER FITTING .VIS, FIXATION DE LEVIER	1	

FIG. 8 FUEL

CARBURANT

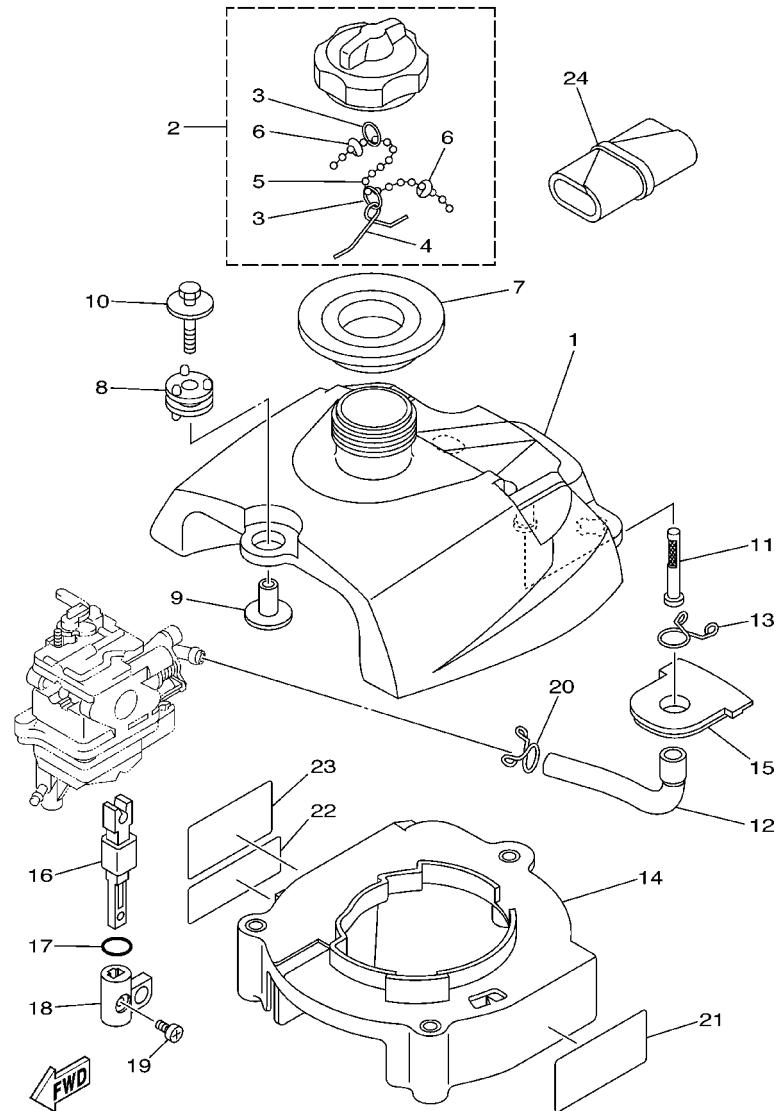

69M1300-3080

REF. NO.	PART NO. NO. PIECES	DESCRIPTION DESCRIPTION	F2.5				REMARKS REMARQUES
1	69M-F4111-00	TANK, FUEL RESERVOIR, A ESSENCE	1				
2	67D-24610-02	CAP ASSY BOUCHON	1				
3	90501-10260	.SPRING, COMPRESSION .RESSORT, COMPRESSION	2				
4	624-24634-00	.HOOK, CHAIN BALL .ATTACHE	1				
5	69M-24633-00	.CHAIN, BALL .CHANÉ DE BALLE	1				
6	6H1-21757-00	.WASHER, SPECIAL 1 .RONDELLE, SPECIALE 1	2				
7	69M-24641-00	GASKET, CAP 1 JOINT 1, BOUCHON	1				
8	69M-F4375-00	GROMMET OEILLET CAOUTCHOUC	3				
9	68F-86129-00	COLLAR COLLERETTE	3				
10	68F-85119-00	BOLT BOULON	3				
11	6L5-24251-00	STRAINER 1 FILTRE 1	1				
12	69M-F4311-00	PIPE, FUEL 1 DURITE A ESSENCE	1				
13	90467-13M13	CLIP JONC	1				
14	69M-F4191-00	BRACKET, FUEL TANK 1 SUPPORT 1, RESERVOIR A ESSENCE	1				
15	69M-F4181-00	DAMPER, LOCATING 1 SILENT-BLOC 1	1				
16	69M-24554-00	SHAFT, COCK AXE, MANETTE DU ROBINET	1				
17	93210-13M43	O-RING JOINT TORIQUE	1				
18	69M-24575-00	LEVER, FUEL CHANGE LEVIER, D'ESSENCE	1				
19	90159-05M12	SCREW, WITH WASHER VIS, AVEC RONDELLE	1				
20	90467-11M08	CLIP JONC	1				
21	69M-13437-60	MARK, CAUTION MAKER	1				
22	6A1-83625-41	MARK 5 ETIQUETTE 5	1				
23	6A1-83625-51	MARK 5 ETIQUETTE 5	1				
24	69M-F8100-00	TOOL KIT TROUSSE A OUTILS	1				

FIG. 9 STARTER

DEMARREUR

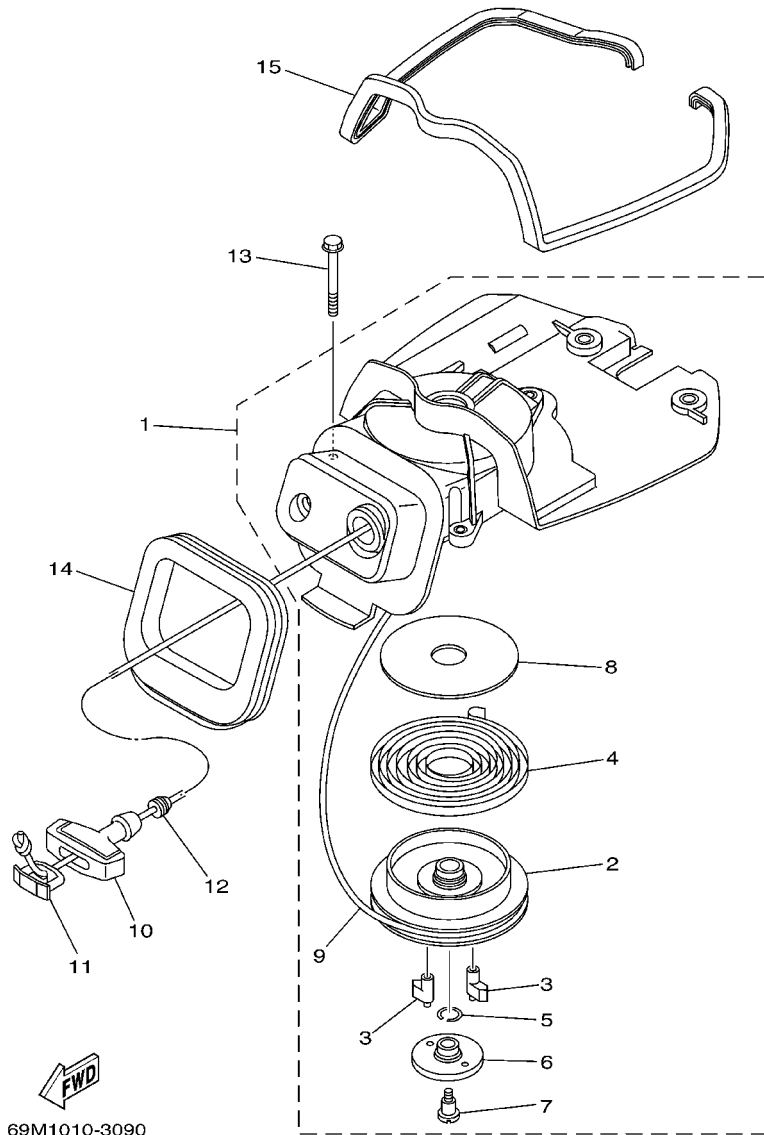

69M1010-3090

REF. NO.	PART NO. NO. PIECES	DESCRIPTION DESCRIPTION	F2.5				REMARKS REMARQUES
1	69M-15710-00	STARTER ASSY DEMARREUR COMPLET	1				
2	69M-15714-00	.DRUM, SHEAVE .TAMBOUR, POULIE	1				
3	69M-15741-00	.PAWL, DRIVE .CLIQUET, ENTRAINEMENT	2				
4	67D-15713-00	.SPRING, STARTER .RESSORT DE DEMARREUR	1				
5	67D-15705-00	.SPRING, DRIVE PAWL .RESSORT DE CLIQUET	1				
6	69M-15735-00	.GUIDE, CAM .COULISSEAU	1				
7	69M-15793-00	.SCREW .VIS	1				
8	69M-15739-00	.WASHER, THRUST .RONDELLE, DE BUTEE	1				
9	69M-15751-00	.WIRE, STARTER (1.5M) .CABLE DE DEMARREUR (1.5M)	1				
10	6G1-15755-00	HANDLE, STARTER POIGNÉE, DE DEMARREUR	1				
11	6G1-15779-00	COVER COUVERCLE	1				
12	69M-E5789-00	DAMPER AMORTISSEUR	1				
13	97595-06560	BOLT, WITH WASHER VIS HEXAGONAL AVEC RONDELLE	3				
14	69M-15762-00	SEAL, RUBBER 2 JOINT CAOUTCHOUC 2	1				
15	69M-24182-00	DAMPER, LOCATING 2 SILENT-BLOC	1				

FIG. 10 GENERATOR

GENERATRICE

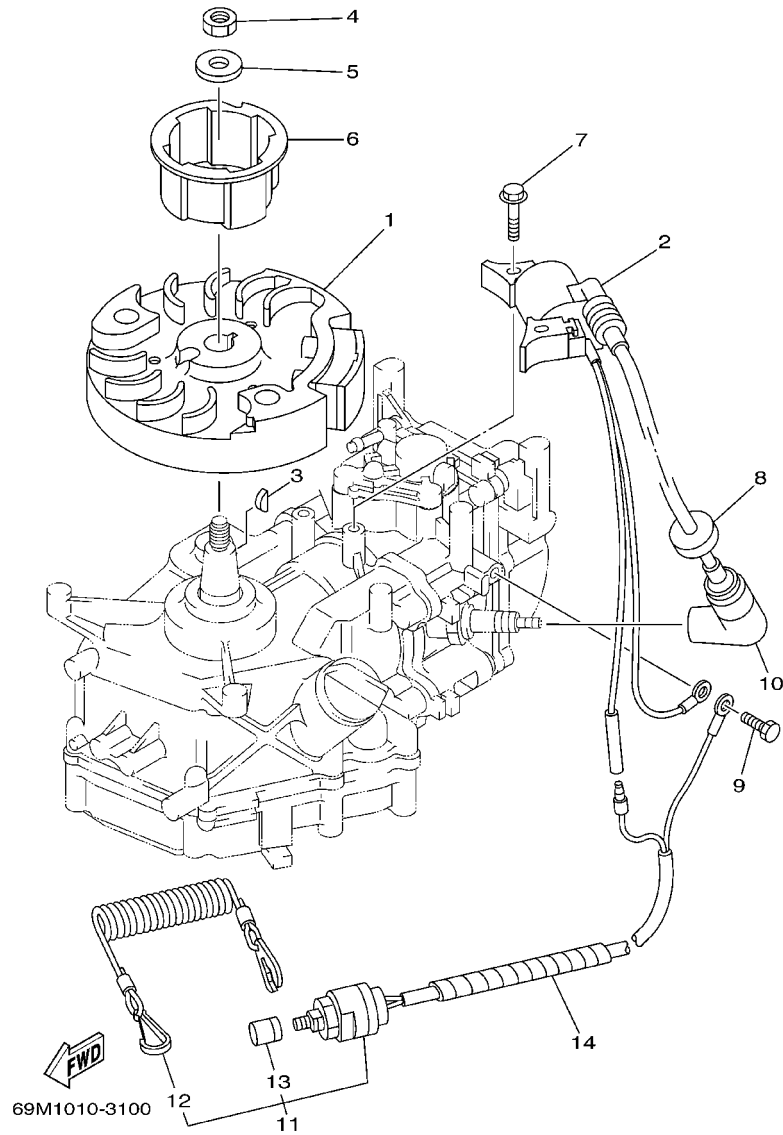

REF. NO.	PART NO. NO. PIECES	DESCRIPTION DESCRIPTION	F2.5				REMARKS REMARQUES
1	69M-85650-00	ROTOR ASSY ROTOR COMPLET	1				
2	69M-85640-00	T.C.I. UNIT ASSY ENS. BLOC T.C.I.	1				
3	90280-04M06	KEY, WOODRUFF CLAVETTE, DEMI-LUNE	1				
4	90170-10M33	NUT ECROU	1				
5	90201-105A2	WASHER, PLATE RONDELLE, PLATE	1				
6	69M-15723-00	PULLEY, STARTER POULIE DE DEMARREUR	1				
7	90105-06M24	BOLT, FLANGE BOULON	2				
8	90480-25161	GROMMET PASSE-FIL	1				
9	97095-06012	BOLT BOULON	1				
10	6E3-82370-21	PLUG CAP ASSY ANTIPARASITE	1				
11	65W-82575-01	ENGINE STOP SWITCH ASSY COUPE CIRCUIT CPLT	1				
12	682-82556-00	.STOPPER .PLAQUETTE	1				
13	689-8257Y-00	.CAP .CHAPEAU	1				
14	90446-06M90	HOSE DURITE	1				

FIG. 11 BOTTOM COWLING

CAPOT INFERIEUR

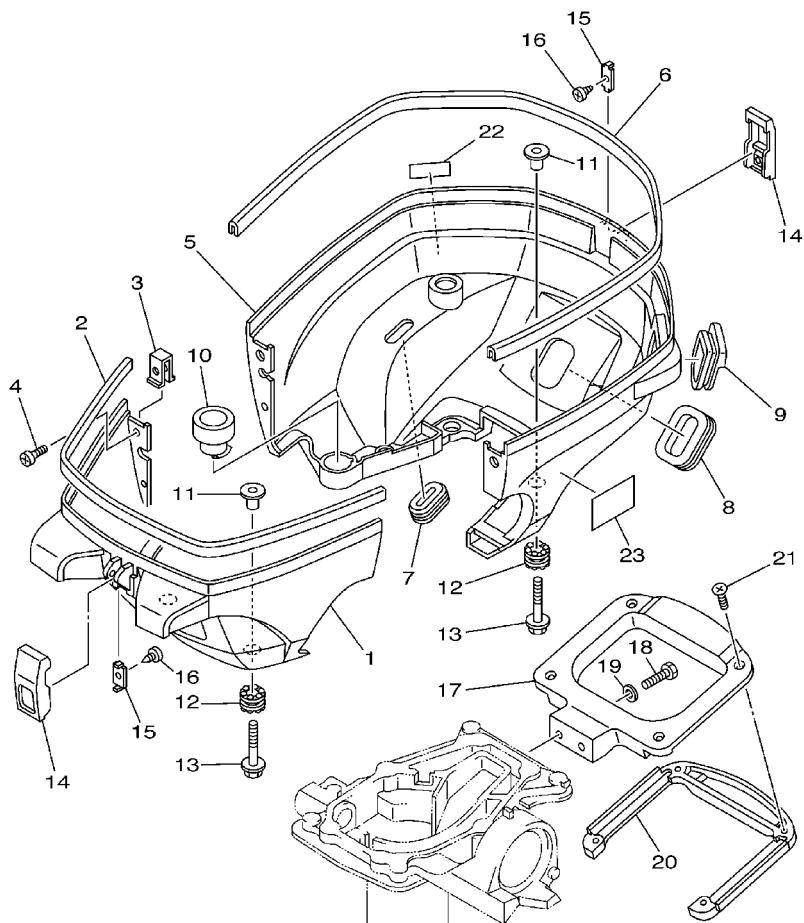

REF. NO.	PART NO. NO. PIECES	DESCRIPTION DESCRIPTION	F2.5				REMARKS REMARQUES
1	69M-G2711-00-4D	COWLING, BOTTOM CUVETTE	1				
2	69M-42628-00	SEAL JOINT	1				
3	6L5-42774-00	STAY, APRON 1 COUSSINET	2				
4	90157-05013	SCREW, PAN HEAD VIS, TETE TRONCONIQUE	2				
5	69M-G2712-00	COWLING, BOTTOM CUVETTE	1				
6	69M-42629-00	SEAL JOINT	1				
7	69M-G2727-00	GROMMET PASSE-FIL	1				
8	69M-G2724-00	GROMMET PASSE-FIL	1				
9	69M-G2725-00	GROMMET PASSE-FIL	1				
10	69M-E5316-00	DAMPER, ENGINE MOUNT 1 AMORTISSEUR DE SUPPORT	1				
11	69M-42758-00	COLLAR ENTRETOISE	4				
12	69M-G2768-00	DAMPER AMORTISSEUR	4				
13	90119-06M17	BOLT, WITH WASHER BOULON, AVEC RONDELLE	4				
14	6L5-42647-00	HOLDER, CLAMP BAND SUPPORT, SANDOW DE SERRAGE	2				
15	6L5-42823-00	PLATE, STOP PLAQUE	2				
16	90167-03M02	SCREW, TAPPING VIS, TETE FRAISEE	2				
17	69M-G2731-00-4D	CARRYING HANDLE POIGNEE DE PORTAGE	1				
18	97095-06020	BOLT BOULON	2				
19	92995-06600	WASHER RONDELLE	2				
20	69M-G2735-00	PROTECTOR PROTECTEUR	1				
21	90161-04003	SCREW, TAPPING VIS, TETE FRAISEE	4				
22	69M-24591-00	EMBLEM, FUEL COCK ADHESIF	1				
23	69M-13444-50	MARK MARKER	1				



69M1010-3110

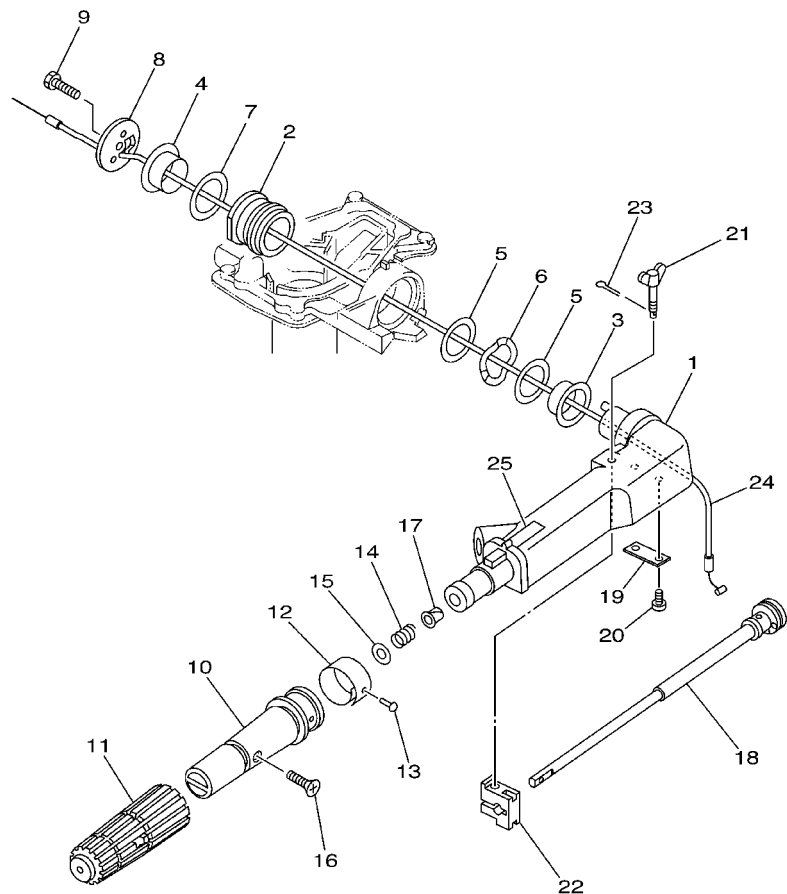

69M1300-3120

FIG. 12 STEERING

DIRECTION

REF. NO.	PART NO. NO. PIECES	DESCRIPTION DESCRIPTION	F2.5				REMARKS REMARQUES
1	69M-G2111-00-4D	HANDLE, STEERING POIGNEE	1				
2	67D-42129-00	BUSHING, RUBBER DOUILLE, CAOUTCHOUC	1				
3	68D-G2171-00	BUSHING COUSSINET	1				
4	68D-G2172-00	BUSHING 2 DOUILLE 2	1				
5	68D-G2181-00	WASHER RONDELLE	2				
6	69M-G2188-00	WASHER, WAVE RONDELLE, ONDULEE	1				
7	68D-G2182-00	WASHER 2 RONDELLE 2	1				
8	68D-G2131-01	COVER, HANDLE STEERING COUVERCLE	1				
9	97075-08025	BOLT BOULON	1				
10	69M-G2119-10	GRIP, STEERING HANDLE POIGNEE, BARRE FRANCHE	1				
11	6N0-G2177-00	RUBBER, HANDLE CAOUTCHOUC, POIGNEE	1				
12	69M-G2137-00	INDICATOR, THROTTLE INDICATEUR, ACCELERATION	1				
13	90269-02M09	RIVET RIVET	1				
14	90501-23800	SPRING, COMPRESSION RESSORT, COMPRESSION	1				
15	92903-10600	WASHER, PLATE RONDELLE, PLATE	1				
16	90149-05M13	SCREW VIS	1				
17	90386-08032	BUSH DOUILLE	1				
18	69M-G2138-00	LEVER, THROTTLE LEVIER, ACCELERATEUR	1				
19	68D-G2159-00	STAY SUPPORT	1				
20	97885-05012	SCREW, PAN HEAD VIS, A ENCOCHE	2				
21	6G1-42125-01	BOLT, FRICTION ADJUSTING BOULON	1				
22	6N0-G2126-00	FRICTION, STEERING HANDLE GRIP CUVETTE, POIGNEE DE DIRECTION	1				
23	91490-16010	PIN, COTTER GOUPILLE	1				
24	69M-F6301-00	THROTTLE CABLE ASSY CABLE D'ACCELERATEUR	1				
25	68D-H257H-00	PLATE, MARK PLAQUE, ADHESIF	1				

FIG. 13 CONTROL

COMMANDE

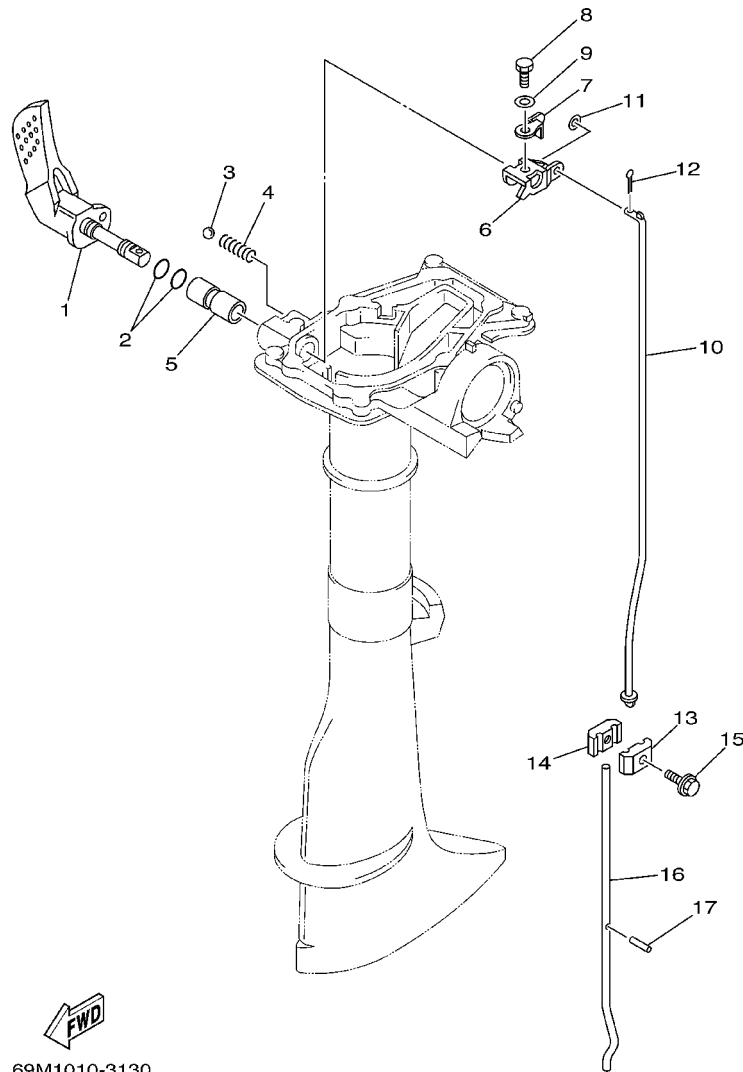

FWD
69M1010-3130

REF. NO.	PART NO. NO. PIECES	DESCRIPTION DESCRIPTION	F2,5				REMARKS REMARQUES
1	69M-G4111-00	HANDLE, GEAR SHIFT POIGNEE, LEVIER D'EMBRAYAGE	1				
2	93210-09350	O-RING JOINT TORIQUE	2				
3	93505-16024	BALL BILLE ROULEMENT	1				
4	90501-12802	SPRING, COMPRESSION RESSORT, COMPRESSION	1				
5	68D-G4122-01	BUSHING, SHIFT ROD LEVER DOUILLE, LEVIER D'EMBRAYAGE	1				
6	69M-G4121-00	LEVER, SHIFT ROD LEVIER, TIGE D'INVERSION	1				
7	69M-44126-00	WASHER, SHIFT ROD LEVER RONDELLE, TIGE D'INVERSION LEV	1				
8	97095-05012	BOLT BOULON	1				
9	92995-05600	WASHER RONDELLE	1				
10	69M-44143-00	ROD, SHIFT TIGE D'EMBRAYAGE	1				
11	92990-05600	WASHER, PLATE RONDELLE, PLATE	1				
12	91490-16010	PIN, COTTER GOUILLE	1				
13	6N0-G4145-10	CONNECTOR, SHIFT ROD CONNECTEUR, TIGE D'INVERSION	1				
14	6N0-G4146-10	CONNECTOR, SHIFT ROD CONNECTEUR, TIGE D'INVERSION	1				
15	90119-06ME0	BOLT, WITH WASHER BOULON, AVEC RONDELLE	1				
16	6L5-44144-00	ROD, SHIFT TIGE D'EMBRAYAGE	1				S
	6L5-44144-10	ROD, SHIFT TIGE D'EMBRAYAGE	1				L
17	91609-25014	PIN, SPRING AXE DE RESSORT	1				

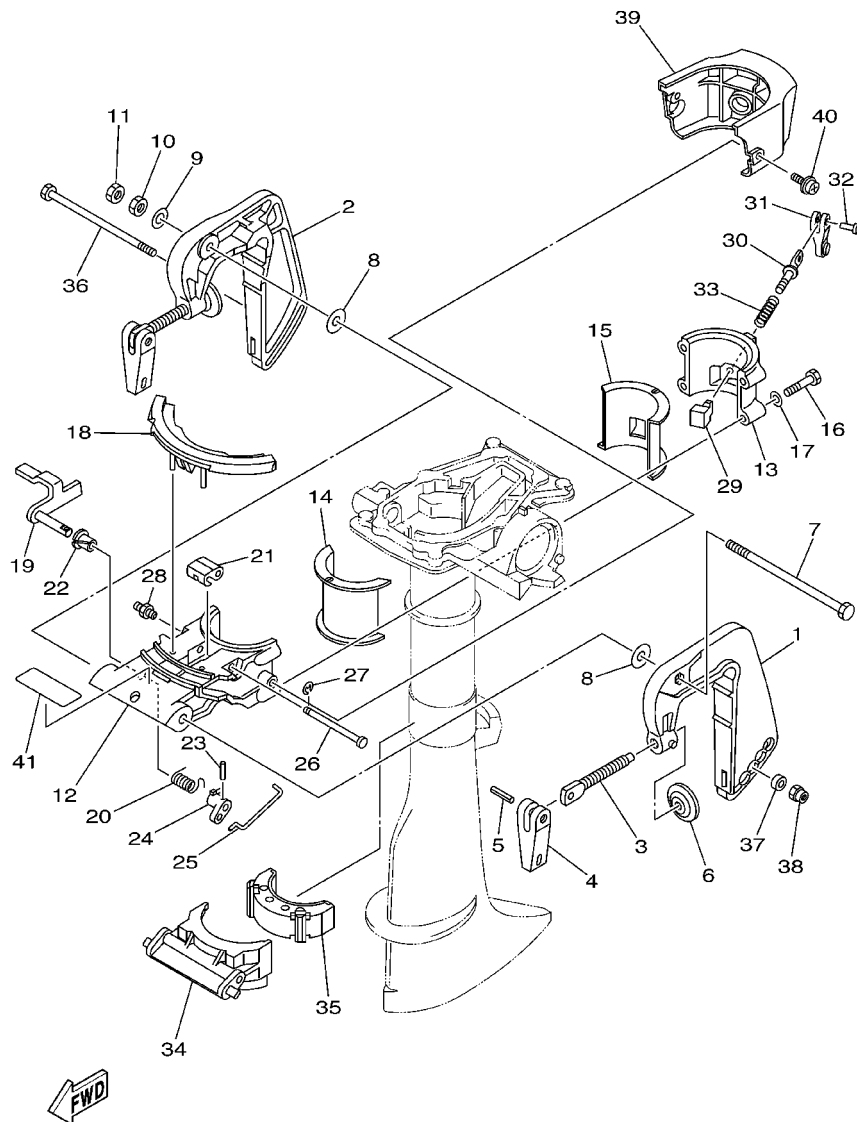

69M1010-3140

FIG. 14 BRACKET

SUPPORT

REF. NO.	PART NO. NO. PIECES	DESCRIPTION DESCRIPTION	F2.5				REMARKS REMARQUES
1	69M-G3111-00-4D	BRACKET, CLAMP PRESSE	1				
2	69M-G3112-00-4D	BRACKET, CLAMP PRESSE	1				
3	6E0-43116-01	SCREW, TRANSOM CLAMP VIS DE PRESSE	2				
4	69M-G3118-00	HANDLE, TRANSOM CLAMP POIGNEE DE VIS DE PRESSE	2				
5	90243-04M01	PIN GOUPILLE	2				
6	620-43114-00	PAD, TRANSOM CLAMP RONDELLE D'APPUI	2				
7	90101-08M07	BOLT BOULON	1				
8	90202-08022	WASHER, PLATE RONDELLE, PLATE	2				
9	92990-08200	WASHER, PLAIN RONDELLE, PLATE	1				
10	95380-08600	NUT ECROU	1				
11	95380-08700	NUT ECROU	1				
12	69M-G3311-00-4D	BRACKET, SWIVEL 1 SUPPORT, PIVOT 1	1				
13	69M-G3312-00-4D	BRACKET, SWIVEL 2 SUPPORT, PIVOT 2	1				
14	69M-G2537-00	BUSHING, PIVOT SHAFT COUSSINET	1				
15	69M-G2538-00	BUSHING, PIVOT SHAFT COUSSINET	1				
16	97075-06030	BOLT BOULON	4				
17	92995-06600	WASHER RONDELLE	4				
18	69M-43679-00	STOPPER, HOOK BUTEE	1				
19	69M-43180-00	TILT STOP LEVER ASSY LEVIER, VERROUILLAGE RELEVAGE	1				
20	69M-G3188-00	SPRING RESSORT	1				
21	69M-G3186-00	LEVER LEVIER	1				
22	90386-08032	BUSH DOUILLE	1				
23	91690-20010	PIN, SPRING AGRAFFE	1				
24	69M-G3185-00	LEVER, TILT STOP LEVIER, VERROUILLAGE RELEVAGE	1				
25	69M-G3164-00	ROD, TILT LOCK TIGE	1				
26	69M-G3166-00	PIN GOUPILLE	1				
27	99080-04600	CIRCLIP CIRCLIP	1				

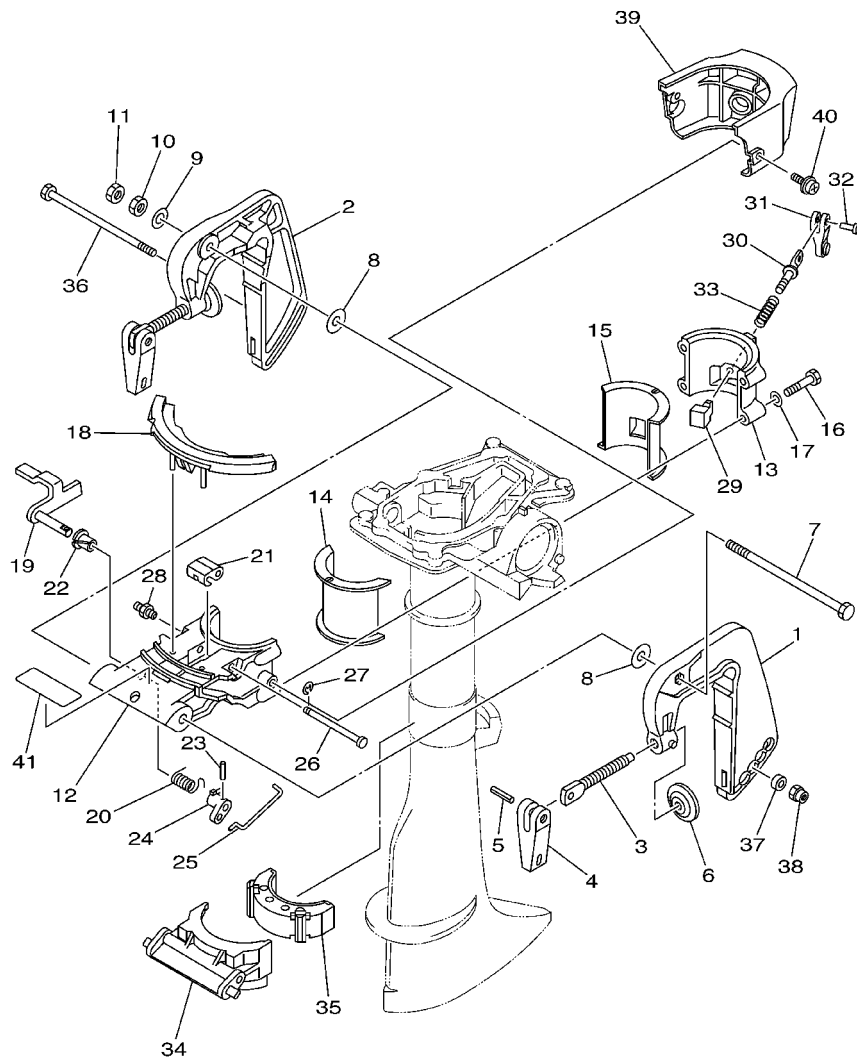

FWD
69M1010-3140

FIG. 14 BRACKET

SUPPORT

REF. NO.	PART NO. NO. PIECES	DESCRIPTION DESCRIPTION	F2.5	REMARKS REMARQUES
28	93700-06M03	NIPPLE, GREASE PION	1	
29	69M-42528-00	PLATE, FRICTION PLAQUE, FRICTION	1	
30	69M-42529-00	SCREW, FRICTION PIECE VIS, PIECE DE FRICTION	1	
31	68D-G2561-01	KNOB, STEERING LOCK BOUTON	1	
32	90266-04M05	RIVET RIVET	1	
33	90501-12803	SPRING, COMPRESSION RESSORT, COMPRESSION	1	
34	69M-G3351-00	RECEIVER, THRUST SILENT-BLOC, BUTEE	1	
35	69M-44557-00	MOUNT DAMPER, LOWER FRONT SILENT-BLOC, INFERIEUR AVANT	1	
36	90101-06030	BOLT BOULON	1	
37	90201-06040	WASHER, PLATE RONDELLE, PLATE	1	
38	95780-06300	NUT, FLANGE ECROU	1	
39	69M-G3318-00	COVER CAPUCHON	1	
40	90159-06M11	SCREW, WITH WASHER VIS, AVEC RONDELLE	2	
41	69M-G3691-00	INDICATOR, TILT ETIQUETTE, RELEVAGE	1	

FIG. 15 UPPER CASING

FOURREAU

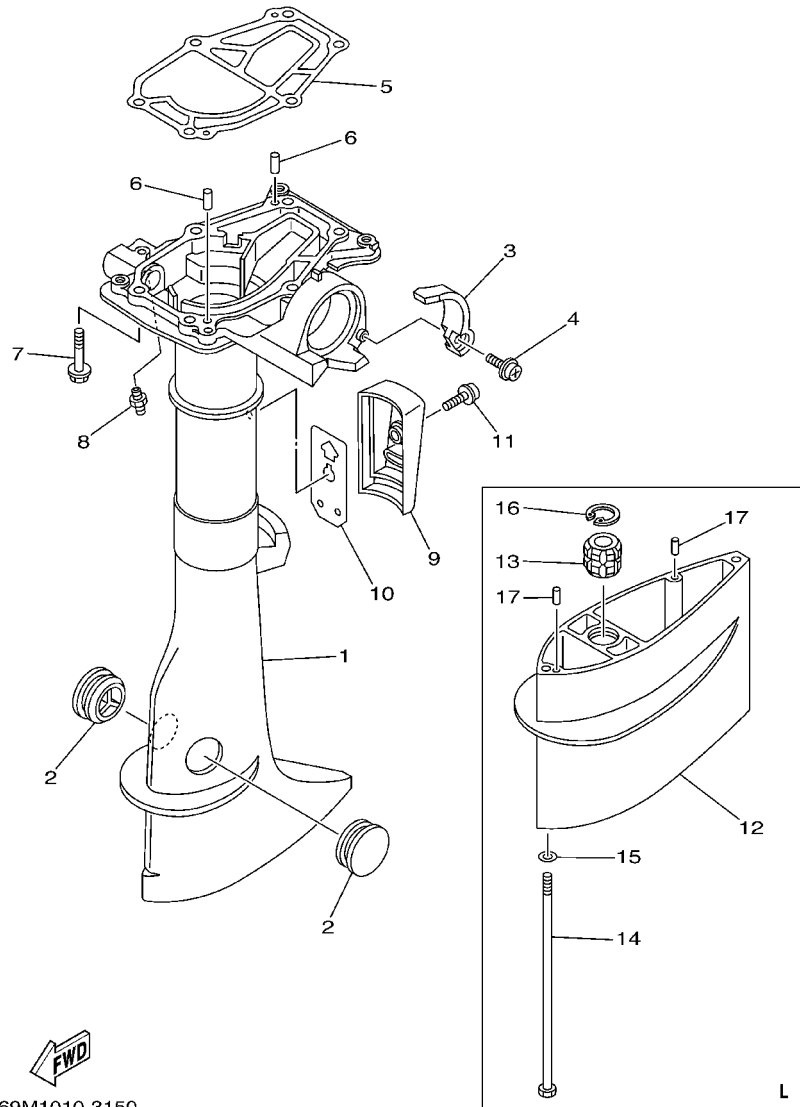

FWD
69M1010-3150

REF. NO.	PART NO. NO. PIECES	DESCRIPTION DESCRIPTION	F2.5				REMARKS REMARQUES
1	69M-G5111-00-4D	CASING, UPPER FOURREAU	1				
2	647-45151-01	COVER, UPPER CASING CAPUCHON, FOURREAU	2				
3	69M-G5152-00	COVER, UPPER CASING 2 CAPUCHON FOURREAU	1				
4	90159-05M12	SCREW, WITH WASHER VIS, AVEC RONDELLE	1				
5	69M-45113-A0	GASKET, UPPER CASING JOINT, TUBE D'ARBRE	1				
6	93604-12M07	PIN, DOWEL CLAVETTE	2				
7	97575-06535	BOLT, WITH WASHER VIS HEXAGONAL AVEC RONDELLE	6				
8	93700-06M03	NIPPLE, GREASE PION	1				
9	69M-G5151-00	COVER, UPPER CASING CAPUCHON, FOURREAU	1				
10	69M-G5115-00	GASKET, UPPER CASING JOINT, TUBE D'ARBRE	1				
11	90159-06M11	SCREW, WITH WASHER VIS, AVEC RONDELLE	1				
12	69M-G5211-00-4D	EXTENSION EXTENSION	1				L
13	6L5-45318-00	BUSHING, DRIVE SHAFT DOUILLE, ARBRE MOTEUR	1				L
14	90101-06M18	BOLT BOULON	3				L
15	92990-06600	WASHER, PLATE RONDELLE, PLATE	3				L
16	93420-22M03	CIRCLIP CIRCLIP, TYPE S	1				L
17	93604-12M07	PIN, DOWEL CLAVETTE	2				L

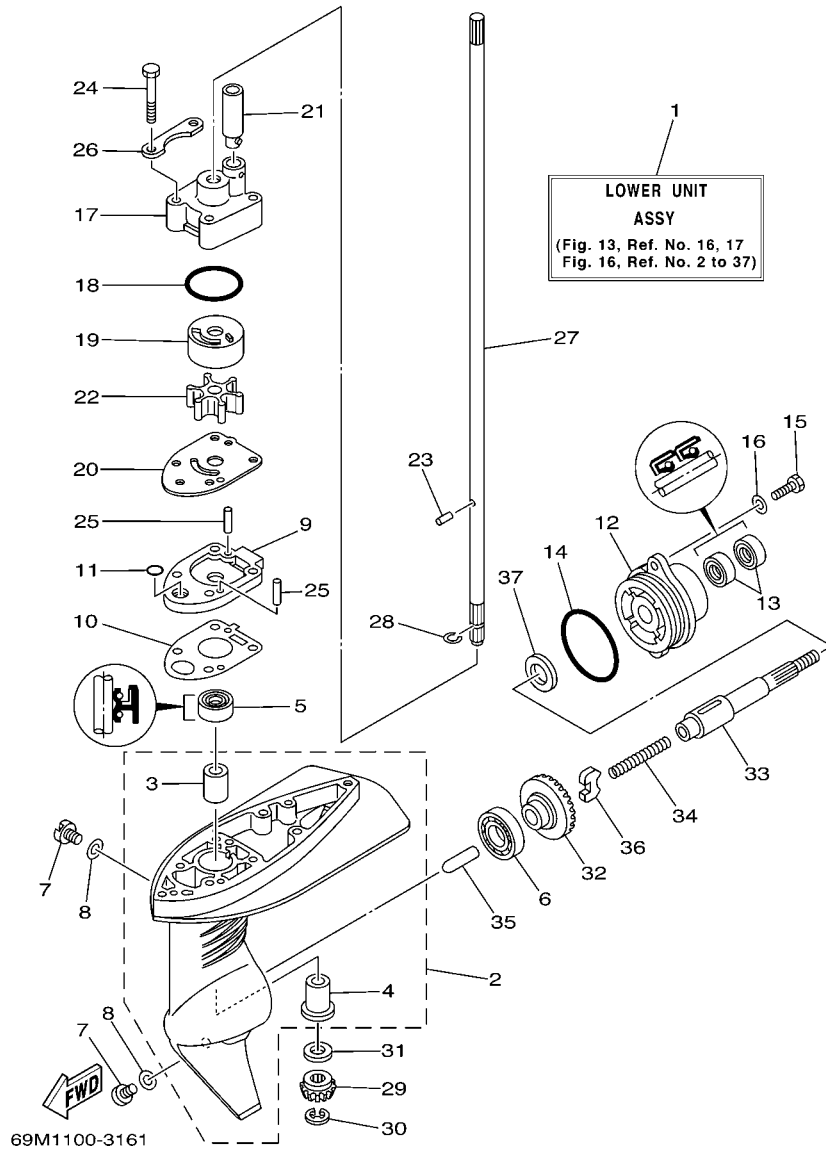

FIG. 16 LOWER CASING. DRIVE 1

BOITIER D'HELICE, TRANSMISSION 1

REF. NO.	PART NO. NO. PIECES	DESCRIPTION DESCRIPTION	F2.5				REMARKS REMARQUES
1	69M-G5300-00-4D	LOWER UNIT ASSY UNITE INFERIEURE (ENS.)	1				S
	69M-G5300-10-4D	LOWER UNIT ASSY UNITE INFERIEURE (ENS.)	1				L
2	69M-G5311-00-4D	CASING, LOWER BOITIER D'HELICE	1				
3	6L5-45316-09	.BUSHING, DRIVE SHAFT .DOUILLE, ARBRE MOTEUR	1				
4	6L5-45317-09	.BUSHING, DRIVE SHAFT .DOUILLE, ARBRE MOTEUR	1				
5	93103-09M41	OIL SEAL JOINT SPY	1				
6	93316-003Y0	BEARING ROULEMENT	1				
7	90340-08002	PLUG, STRAIGHT SCREW PLOT, FILETE DROIT	2				
8	90430-08801	GASKET JOINT	2				
9	69M-G5321-00-94	PLATE PLAQUETTE	1				
10	69M-G5315-A0	PACKING, LOWER CASING JOINT, BOITIER D'HELICE	1				
11	93210-05001	O-RING JOINT TORIQUE	1				
12	69M-G5361-00-4D	CAP, LOWER CASING COUVERCLE, BOITIER D'HELICE	1				
13	93101-13M12	OIL SEAL JOINT SPY	2				
14	93210-48214	O-RING JOINT TORIQUE	1				
15	97095-06016	BOLT BOULON	2				
16	92995-06600	WASHER RONDELLE	2				
17	69M-G4311-00	HOUSING, WATER PUMP CORPS, POMPE A EAU	1				
18	93210-33M85	O-RING JOINT TORIQUE	1				
19	6L5-44322-00	INSERT, CARTRIDGE CUVETTE	1				
20	69M-G4323-00	OUTER PLATE, CARTRIDGE PLAQUE EXTERIEURE	1				
21	6E0-44366-00	DAMPER, WATER SEAL JOINT, TUBE D'EAU	1				
22	6L5-44352-00	IMPELLER TURBINE	1				
23	93604-07M13	PIN, DOWEL CLAVETTE	1				
24	97095-06040	BOLT BOULON	4				
25	93604-18080	PIN, DOWEL CLAVETTE	2				
26	69M-G4328-00	PLATE PLAQUETTE	2				

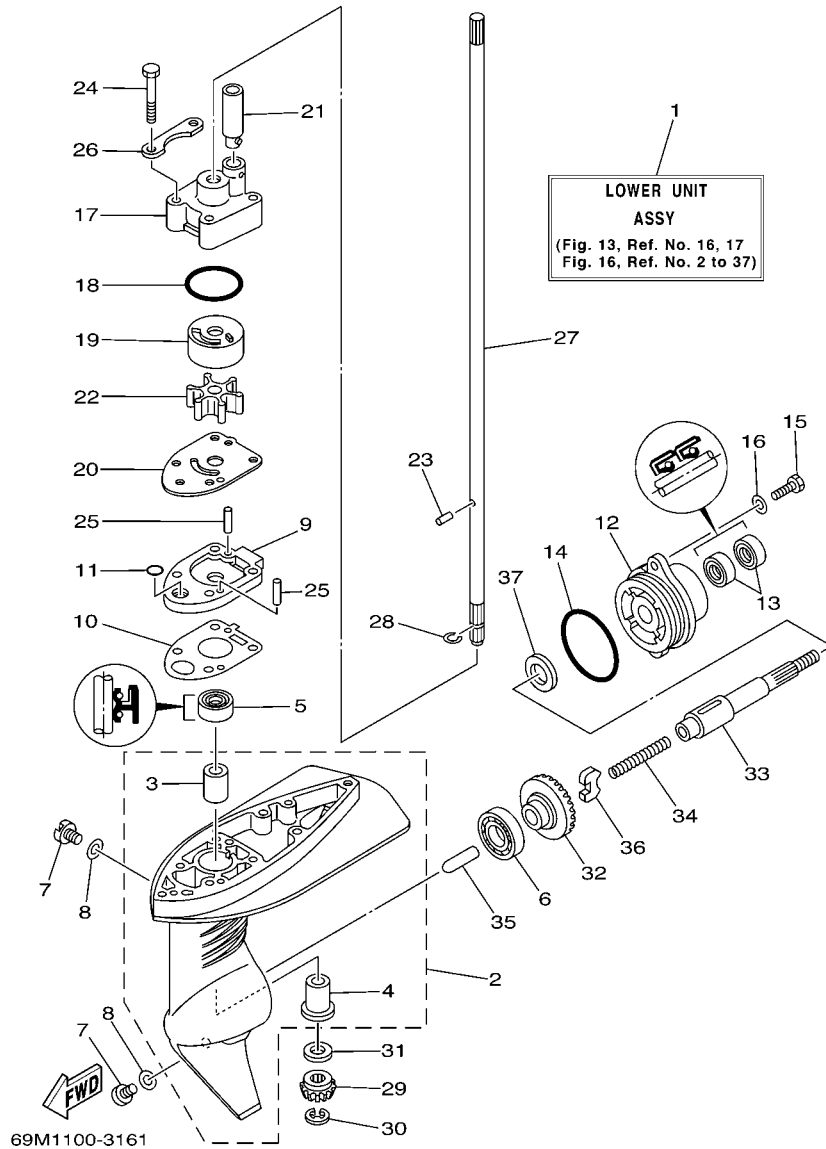

FIG. 16 LOWER CASING. DRIVE 1

BOITIER D'HELICE, TRANSMISSION 1

REF. NO.	PART NO. NO. PIECES	DESCRIPTION DESCRIPTION	F2.5				REMARKS REMARQUES
27	69M-G5511-00	SHAFT, DRIVE ARBRE, MOTEUR	1				S
	69M-G5511-10	SHAFT, DRIVE ARBRE, MOTEUR	1				L
28	93440-08819	CIRCLIP CIRCLIP	1				
29	6L5-45551-00	PINION PIGNON D'ATTAQUE	1				
30	99001-06600	CIRCLIP CIRCLIP	1				
31	6L5-45533-00-20	SHIM (T:2.0MM) CALE (T:2.0MM)	1				UR
	6L5-45533-00-21	SHIM (T:2.1MM) CALE (T:2.1MM)	1				UR
	6L5-45533-00-22	SHIM (T:2.2MM) CALE (T:2.2MM)	1				UR
	6L5-45533-00-23	SHIM (T:2.3MM) CALE (T:2.3MM)	1				UR
32	6L5-45560-00	GEAR PIGNON	1				
33	6L5-45611-00	SHAFT, PROPELLER ARBRE, HELICE	1				
34	90501-10064	SPRING, COMPRESSION RESSORT, COMPRESSION	1				
35	69M-G5635-00	PLUNGER, SHIFT POUSSOIR D'EMBRAYAGE	1				
36	6L5-45631-00	CLUTCH, DOG CRABOT	1				
37	90201-13198	WASHER, PLATE RONDELLE, PLATE	1				

FIG. 17 LOWER CASING. DRIVE 2

BOITIER D'HELICE, TRANSMISSION 2

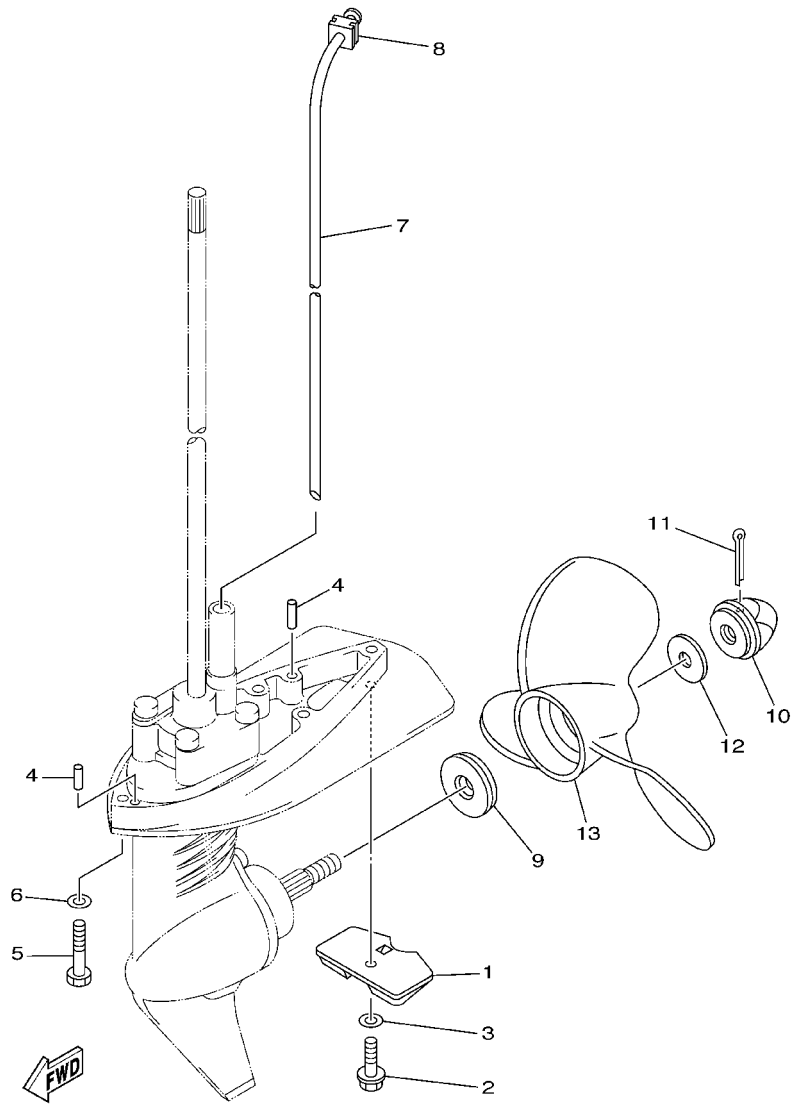

69M1010-3170

REF. NO.	PART NO. NO. PIECES	DESCRIPTION DESCRIPTION	F2.5				REMARKS REMARQUES
1	68D-G5251-00	ANODE ANODE	1				
2	95895-06020	BOLT, FLANGE BOULON	1				
3	92990-06300	WASHER, INTERNAL TOOTH RONDELLE, DENTURE INTERNE	1				
4	93604-12M07	PIN, DOWEL CLAVETTE	2				
5	97095-06030	BOLT BOULON	3				S
6	92995-06600	WASHER RONDELLE	3				S
7	69M-44361-00	TUBE, WATER TUBE D'EAU	1				S
	69M-44361-10	TUBE, WATER TUBE D'EAU	1				L
8	68D-G4365-00	DAMPER, WATER SEAL JOINT, TUBE D'EAU	1				
9	68D-G5987-00	SPACER ENTRETOISE	1				
10	6L5-45616-00	NUT, PROPELLER CONE, HELICE	1				
11	91490-25030	PIN, COTTER GOUPILLE	1				
12	90201-08M54	WASHER, PLATE RONDELLE, PLATE	1				
13	6L5-45943-00-EL	PROPELLER (3X7-1/4"X6"-BS) HELICE (3X7-1/4"X6"-BS)	1				UR
	6L5-45945-00-EL	PROPELLER (3X7-1/4"X7-1/4"-BS) HELICE (3X7-1/4"X7-1/4"-BS)	1				UR
	6L5-45947-00-EL	PROPELLER (3X7-1/4"X8-1/4"-BS) HELICE (3X7-1/4"X8-1/4"-BS)	1				UR
	6L5-45949-00-EL	PROPELLER (3X7-1/4"X5"-BS) HELICE (3X7-1/4"X5"-BS)	1				UR
	6L5-45952-00-EL	PROPELLER[(3X7-1/4"X5-1/2"-BS)] HELICE[(3X7-1/4"X5-1/2"-BS)]	1				UR

D2

FIG. 18 REPAIR KIT 1

KITS DE REPARATION 1

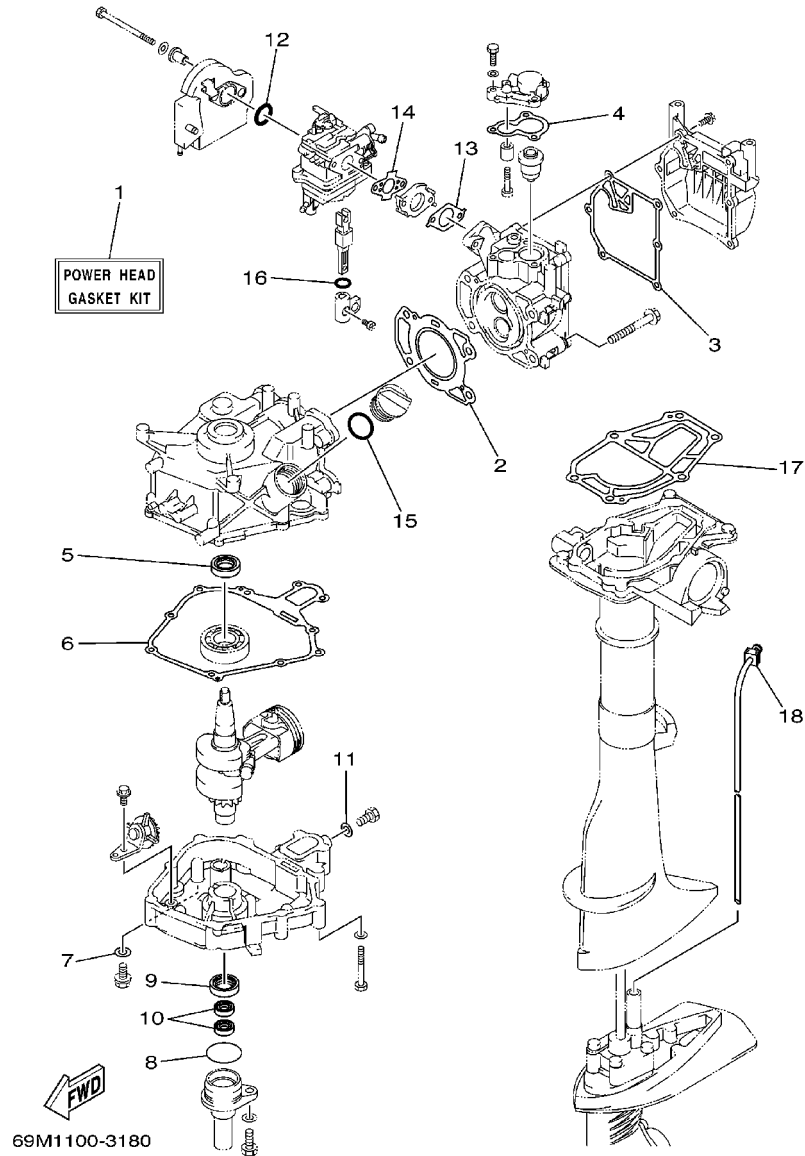

REF. NO.	PART NO. NO. PIECES	DESCRIPTION DESCRIPTION	F2.5				REMARKS REMARQUES
1	69M-WE001-00	POWER HEAD GASKET KIT POCHETTE DE JINTS TETE MOTRICE	1				
2	69M-11181-00	.GASKET, CYLINDER HEAD 1 .JOINT, DE CULASSE 1	1				
3	69M-11193-A0	.GASKET, HEAD COVER 1 .JOINT, COUVERCLE DE CULASSE 1	1				
4	68D-E2414-A0	.GASKET, COVER .JOINT, COUVERCLE	1				
5	93102-20108	.OIL SEAL .JOINT SPY	1				
6	69M-11351-A0	.GASKET, CYLINDER .JOINT, D'EMBASE	1				
7	90201-08818	.WASHER, PLATE .RONDELLE, PLATE	1				
8	93210-35537	.O-RING .JOINT TORIQUE	1				
9	93102-20108	.OIL SEAL .JOINT SPY	1				
10	93102-09004	.OIL SEAL .JOINT SPY	2				
11	93430-08800	.CIRCLIP .CLIPS	1				
12	93210-20M65	.O-RING .JOINT TORIQUE	1				
13	69M-E3645-A0	.GASKET, MANIFOLD 1 .JOINT, TUBULURE 1	1				
14	69M-E3646-A0	.GASKET, MANIFOLD 2 .JOINT, TUBULURE 2	1				
15	93210-24M79	.O-RING .JOINT TORIQUE	1				
16	93210-13M43	.O-RING .JOINT TORIQUE	1				
17	69M-45113-A0	.GASKET, UPPER CASING .JOINT, TUBE D'ARBRE	1				
18	68D-G4365-00	.DAMPER, WATER SEAL .JOINT, TUBE D'EAU	1				

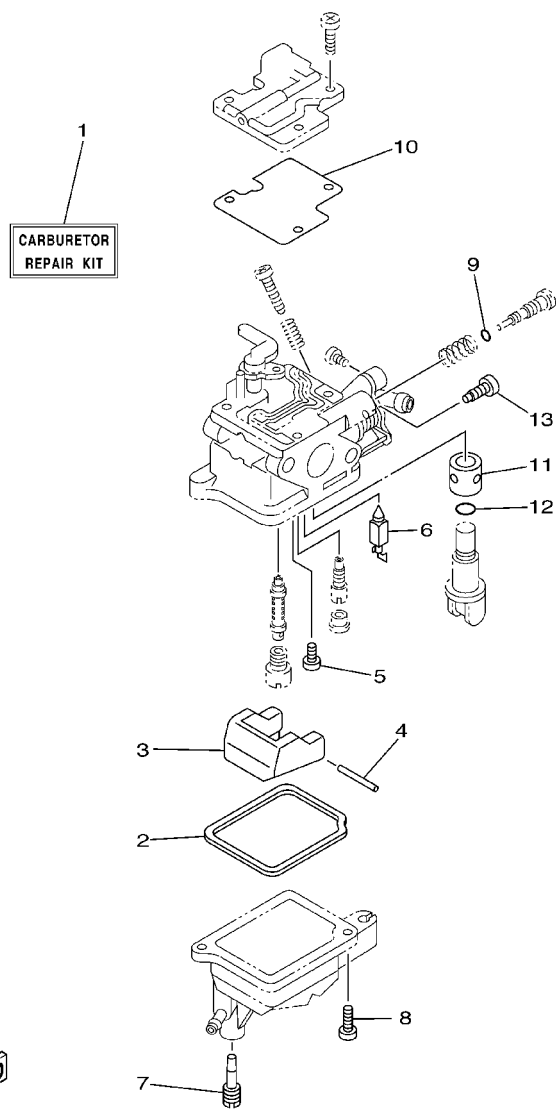

69M1100-3190

FIG. 19 REPAIR KIT 2

KITS DE REPARATION 2

REF. NO.	PART NO. NO. PIECES	DESCRIPTION DESCRIPTION	F2.5				REMARKS REMARQUES
1	69M-W0093-00	CARBURETOR REPAIR KIT KIT DE REPARATION CARBURATEUR	1				
2	69M-14984-00	.GASKET, FLOAT CHAMBER .JOINT, CUVE DE FLOTTEUR	1				
3	69M-14385-00	.FLOAT .FLOTTEUR	1				
4	6A1-14386-00	.PIN, FLOAT .AXE, FLOTTEUR	1				
5	98580-03005	.SCREW, PAN HEAD .VIS	1				
6	62Y-14392-00	.VALVE, NEEDLE .POINTEAU	1				
7	69M-14991-00	.SCREW .VIS	1				
8	98580-04010	.SCREW, PAN HEAD .VIS	2				
9	2T4-14397-00	.O-RING .JOINT TORIQUE	1				
10	69M-14536-00	.GASKET .JOINT	1				
11	69M-24523-00	.VALVE .SOUPAPE	1				
12	69M-24533-00	.O-RING .JOINT TORIQUE	1				
13	69M-24535-00	.SCREW, LEVER FITTING .VIS, FIXATION DE LEVIER	1				

FIG. 20 REPAIR KIT 3

KITS DE PEPARATION 3

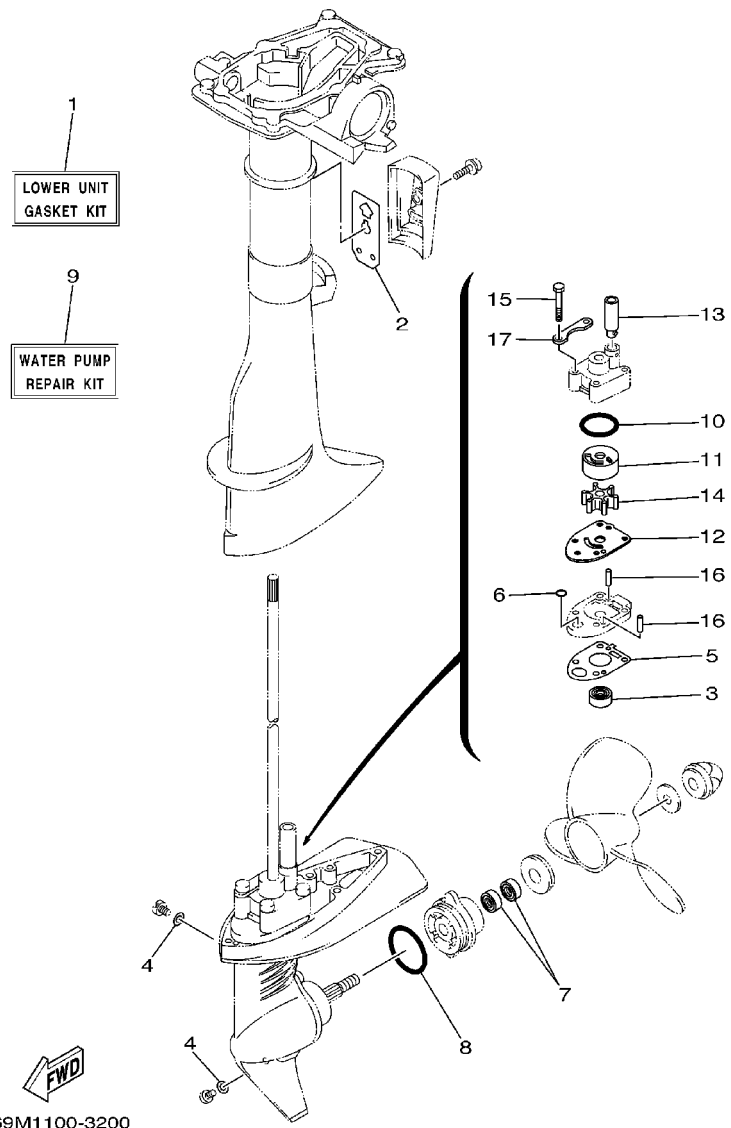

REF. NO.	PART NO. NO. PIECES	DESCRIPTION DESCRIPTION	F2.5				REMARKS REMARQUES
1	69M-WG001-20	LOWER UNIT GASKET KIT POCHETTE DE JOINTS EMBASE	1				
2	69M-G5115-00	.GASKET, UPPER CASING .JOINT, TUBE D'ARBRE	1				
3	93103-09M41	.OIL SEAL .JOINT SPY	1				
4	90430-08801	.GASKET .JOINT	2				
5	69M-G5315-A0	.PACKING, LOWER CASING .JOINT, BOITIER D'HELICE	1				
6	93210-05001	.O-RING .JOINT TORIQUE	1				
7	93101-13M12	.OIL SEAL .JOINT SPY	2				
8	93210-48214	.O-RING .JOINT TORIQUE	1				
9	69M-WG078-00	WATER PUMP REPAIR KIT KIT DE REPARATION DE LA POMPE	1				
10	93210-33M85	.O-RING .JOINT TORIQUE	1				
11	6L5-44322-00	.INSERT, CARTRIDGE .CUVETTE	1				
12	69M-G4323-00	.OUTER PLATE, CARTRIDGE .PLAQUE EXTERIEURE	1				
13	6E0-44366-00	.DAMPER, WATER SEAL .JOINT, TUBE D'EAU	1				
14	6L5-44352-00	.IMPELLER .TURBINE	1				
15	97095-06040	BOLT BOULON	4				
16	93604-18080	.PIN, DOWEL .CLAVETTE	2				
17	69M-G4328-00	.PLATE .PLAQUETTE	2				

NUMERICAL INDEX
INDEX NUMERIQUE

PART NO. NO. PIECES	REF. NO.	PART NO. NO. PIECES	REF. NO.	PART NO. NO. PIECES	REF. NO.	PART NO. NO. PIECES	REF. NO.	PART NO. NO. PIECES	REF. NO.	PART NO. NO. PIECES	REF. NO.
69M-E1111-00-94	2- 2	69M-G2538-00	14- 15	69M-G5300-10-4D	16- 1	62Y-14334-00	7- 17	69M-24533-00	7- 24	6L5-45533-00-21	16- 31
69M-E1191-00-94	2- 8	68D-G2561-01	14- 31	69M-G5311-00-4D	16- 2	69M-14341-00	7- 4		19- 12	6L5-45533-00-22	16- 31
69M-E1311-00-94	4- 1	69M-G2610-10-4D	1- 1	69M-G5315-A0	16- 10	69M-14342-68	7- 5	69M-24535-00	7- 25	6L5-45533-00-23	16- 31
68D-E1325-00	2- 14	69M-G2613-00	1- 2		20- 5	69M-14343-31	7- 3		19- 13	6L5-45551-00	16- 29
69M-E1603-00	3- 6	69M-G2677-00	1- 5	69M-G5321-00-94	16- 9	69M-14381-00	7- 7	69M-24554-00	8- 16	6L5-45560-00	16- 32
69M-E1631-00-96	3- 5	69M-G2678-10	1- 6	69M-G5361-00-4D	16- 12	69M-14385-00	7- 9	69M-24575-00	8- 18	6L5-45611-00	16- 33
69M-E1633-00	3- 7	69M-G2711-00-4D	11- 1	69M-G5511-00	16- 27		19- 3	69M-24591-00	11- 22	6L5-45616-00	17- 10
68D-E2113-00	5- 5	69M-G2712-00	11- 5	69M-G5511-10	16- 27	6A1-14386-00	7- 10	67D-24610-02	8- 2	6L5-45631-00	16- 36
68D-E2138-60	2- 22	69M-G2724-00	11- 8	69M-G5635-00	16- 35		19- 4	69M-24633-00	8- 5	6L5-45943-00-EL	17- 13
69M-E2155-00	5- 12	69M-G2725-00	11- 9	68D-G5987-00	17- 9	62Y-14392-00	7- 12	624-24634-00	8- 4	6L5-45945-00-EL	17- 13
69M-E2413-00-9M	2- 12	69M-G2727-00	11- 7	68D-H257H-00	12- 25		19- 6	69M-24641-00	8- 7	6L5-45947-00-EL	17- 13
68D-E2414-A0	2- 16	69M-G2731-00-4D	11- 17	69M-WE001-00	18- 1	2T4-14397-00	7- 16	6G1-42125-01	12- 21	6L5-45949-00-EL	17- 13
	18- 4	69M-G2735-00	11- 20	69M-WE090-00-4D	2- 1		19- 9	67D-42129-00	12- 2	6L5-45952-00-EL	17- 13
69M-E2483-00	6- 8	69M-G2743-00	4- 26	69M-WG001-20	20- 1	69M-14427-60	1- 9	69M-42528-00	14- 29	6E3-82370-21	10- 10
69M-E3102-00	4- 22	69M-G2768-00	11- 12	69M-WG070-00	1- 4	69M-14440-00	6- 3	69M-42529-00	14- 30	682-82556-00	10- 12
69M-E3645-A0	6- 10	69M-G3111-00-4D	14- 1	69M-WG078-00	20- 9	6H1-14485-00	4- 2	69M-42628-00	11- 2	689-8257Y-00	10- 13
	18- 13	69M-G3112-00-4D	14- 2	69M-W0093-00	19- 1	69M-14527-00	7- 18	69M-42629-00	11- 6	65W-82575-01	10- 11
69M-E3646-A0	6- 11	69M-G3118-00	14- 4	67D-11133-10	2- 3	69M-14536-00	7- 19	6L5-42647-00	11- 14	6A1-83625-41	8- 22
	18- 14	69M-G3164-00	14- 25	69M-11181-00	2- 7		19- 10	69M-42662-00	1- 7	6A1-83625-51	8- 23
69M-E3647-00	6- 12	69M-G3166-00	14- 26		18- 2	69M-14966-00	7- 6	69M-42758-00	11- 11	68F-85119-00	8- 10
69M-E4148-00	6- 1	69M-G3185-00	14- 24	69M-11193-A0	2- 9	69M-14984-00	7- 8	6L5-42774-00	11- 3	69M-85640-00	10- 2
69M-E5111-00-94	4- 6	69M-G3186-00	14- 21		18- 3		19- 2	67D-42791-10	2- 21	69M-85650-00	10- 1
69M-E5316-00	11- 10	69M-G3188-00	14- 20	69M-11351-A0	4- 7	69M-14991-00	7- 13	6L5-42823-00	11- 15	68F-86129-00	8- 9
69M-E5363-00	4- 24	69M-G3311-00-4D	14- 12		18- 6		19- 7	620-43114-00	14- 6	90101-06M18	15- 14
69M-E5396-00-5B	4- 14	69M-G3312-00-4D	14- 13	676-11372-00	2- 4	69M-15361-00	4- 5	6E0-43116-01	14- 3	90101-06030	14- 36
69M-E5789-00	9- 12	69M-G3318-00	14- 39	69M-11400-00	3- 1	67D-15705-00	9- 5	69M-43180-00	14- 19	90101-08M07	14- 7
69M-F4111-00	8- 1	69M-G3351-00	14- 34	69M-11650-00	3- 3	69M-15710-00	9- 1	69M-43679-00	14- 18	90105-06M14	2- 10
69M-F4181-00	8- 15	69M-G3691-00	14- 41	7FK-11654-00	3- 4	67D-15713-00	9- 4	69M-44126-00	13- 7	90105-06M24	10- 7
69M-F4191-00	8- 14	69M-G4111-00	13- 1	67D-12111-00	5- 2	69M-15714-00	9- 2	69M-44143-00	13- 10	90105-08M36	2- 5
69M-F4311-00	8- 12	69M-G4121-00	13- 6	7NJ-12117-00	5- 6	69M-15723-00	10- 6	6L5-44144-00	13- 16	90105-08M76	4- 12
69M-F4375-00	8- 8	68D-G4122-01	13- 5	7NJ-12118-00	5- 7	69M-15735-00	9- 6	6L5-44144-10	13- 16	90119-06ME0	13- 15
69M-F6301-00	12- 24	6N0-G4145-10	13- 13	51Y-12119-00	5- 4	69M-15739-00	9- 8	6L5-44322-00	16- 19	90119-06M17	11- 13
69M-F6330-00	6- 13	6N0-G4146-10	13- 14	67D-12121-00	5- 3	69M-15741-00	9- 3		20- 11	90149-05M13	12- 16
69M-F8100-00	8- 24	69M-G4311-00	16- 17	67D-12151-00	5- 8	69M-15751-00	9- 9	6L5-44352-00	16- 22	90157-05013	11- 4
69M-G2111-00-4D	12- 1	69M-G4323-00	16- 20	JA9-12153-00	5- 14	6G1-15755-00	9- 10		20- 14	90159-05M12	8- 19
69M-G2119-10	12- 10		20- 12	69M-12154-00	5- 13	69M-15762-00	9- 14	69M-44361-00	17- 7		15- 4
6N0-G2126-00	12- 22	69M-G4328-00	16- 26	67D-12157-00	5- 11	6G1-15779-00	9- 11	69M-44361-10	17- 7	90159-06M11	14- 40
68D-G2131-01	12- 8		20- 17	7FK-12158-00	5- 10	69M-15793-00	9- 7	6E0-44366-00	16- 21		15- 11
69M-G2137-00	12- 12	68D-G4365-00	17- 8	7FK-12165-00	5- 9	6H1-21757-00	8- 6		20- 13	90161-04003	11- 21
69M-G2138-00	12- 18		18- 18	69M-12170-20	5- 1	6A1-2415A-41	1- 10	6G8-44532-00	4- 27	90167-03M02	11- 16
68D-G2159-00	12- 19	69M-G5111-00-4D	15- 1	69M-12411-00	2- 11	6A1-2415A-51	1- 11	69M-44557-00	14- 35	90170-10M33	10- 4
68D-G2171-00	12- 3	69M-G5115-00	15- 10	67F-13434-02	1- 8	6G8-2415E-00	1- 12	69M-45113-A0	15- 5	90201-06040	14- 37
68D-G2172-00	12- 4		20- 2	69M-13437-60	8- 21	69M-24182-00	9- 15		18- 17	90201-08M54	17- 12
6N0-G2177-00	12- 11	69M-G5151-00	15- 9	69M-13444-50	11- 23	6L5-24251-00	8- 11	647-45151-01	15- 2	90201-08818	4- 13
68D-G2181-00	12- 5	69M-G5152-00	15- 3	62Y-14212-00	7- 21	650-24378-00	2- 13	6L5-45316-09	16- 3		18- 7
68D-G2182-00	12- 7	69M-G5211-00-4D	15- 12	69M-14301-20	7- 1	69M-24523-00	7- 23	6L5-45317-09	16- 4	90201-105A2	10- 5
69M-G2188-00	12- 6	68D-G5251-00	17- 1	69W-14321-00	7- 20		19- 11	6L5-45318-00	15- 13	90201-13198	16- 37
69M-G2537-00	14- 14	69M-G5300-00-4D	16- 1	69M-14323-20	7- 15	69M-24524-00	7- 22	6L5-45533-00-20	16- 31	90201-23008	3- 2

NUMERICAL INDEX
INDEX NUMERIQUE

PART NO. NO. PIECES	REF. NO.	PART NO. NO. PIECES	REF. NO.	PART NO. NO. PIECES	REF. NO.	PART NO. NO. PIECES	REF. NO.	PART NO. NO. PIECES	REF. NO.	PART NO. NO. PIECES	REF. NO.
90202-08022	14 - 8	93102-09004	4 - 17	97075-08025	12 - 9						
90243-04M01	14 - 5		18 - 10	97095-05012	13 - 8						
90266-04M05	14 - 32	93102-20108	4 - 3	97095-06012	10 - 9						
90269-02M09	12 - 13		4 - 16	97095-06016	16 - 15						
90280-04M06	10 - 3		18 - 5	97095-06020	2 - 17						
90340-08002	16 - 7		18 - 9		4 - 28						
90386-08032	12 - 17	93103-09M41	16 - 5		11 - 18						
	14 - 22		20 - 3	97095-06030	17 - 5						
90387-063Y3	6 - 7	93210-05001	16 - 11	97095-06040	16 - 24						
90430-08800	4 - 21		20 - 6		20 - 15						
90430-08801	16 - 8	93210-09350	13 - 2	97095-06075	6 - 5						
	20 - 4	93210-13M43	8 - 17	97095-08014	4 - 20						
90445-07805	6 - 9		18 - 16	97095-08020	4 - 18						
90445-09808	2 - 19	93210-20M65	6 - 4	97575-06535	15 - 7						
90446-06M90	10 - 14		18 - 12	97595-06560	9 - 13						
90464-09013	2 - 20	93210-24M79	4 - 25	97780-40012	1 - 3						
90465-08M99	4 - 10		18 - 15	97880-05025	2 - 15						
90465-11M10	6 - 2	93210-33M85	16 - 18	97885-05012	12 - 20						
90467-11M08	8 - 20		20 - 10	97890-04007	7 - 2						
90467-13M13	8 - 13	93210-35537	4 - 15	98580-03005	7 - 11						
90480-25161	10 - 8		18 - 8		19 - 5						
90501-10064	16 - 34	93210-48214	16 - 14	98580-04010	7 - 14						
90501-10260	8 - 3		20 - 8		19 - 8						
90501-12802	13 - 4	93306-272Y2	4 - 4	99001-06600	16 - 30						
90501-12803	14 - 33	93316-003Y0	16 - 6	99080-04600	14 - 27						
90501-23800	12 - 14	93420-22M03	15 - 16								
91490-16010	12 - 23	93430-08800	18 - 11								
	13 - 12	93440-08819	16 - 28								
91490-25030	17 - 11	93450-13130	3 - 8								
91609-25014	13 - 17	93505-16024	13 - 3								
91690-20010	14 - 23	93604-07M13	16 - 23								
92903-06600	4 - 9	93604-12M07	2 - 6								
92903-10600	12 - 15		4 - 11								
92990-05600	13 - 11		15 - 6								
92990-06300	17 - 3		15 - 17								
92990-06600	15 - 15		17 - 4								
92990-08200	14 - 9	93604-18080	16 - 25								
92995-05600	13 - 9		20 - 16								
92995-06600	2 - 18	93700-06M03	14 - 28								
	4 - 29		15 - 8								
	6 - 6	94702-00248	2 - 23								
	11 - 19	95380-08600	14 - 10								
	14 - 17	95380-08700	14 - 11								
	16 - 16	95780-06300	14 - 38								
	17 - 6	95817-06012	4 - 23								
92995-08600	4 - 19	95895-06020	17 - 2								
93101-13M12	16 - 13	97013-06045	4 - 8								
	20 - 7	97075-06030	14 - 16								

F2.5AMH
PARTS CATALOGUE
©2002 by Yamaha Motor Co., Ltd.
1st Edition, May 2002
All rights reserved.
Any reprinting or unauthorized use
without the written permission of
Yamaha Motor Co., Ltd.
is expressly prohibited.

F2.5AMH
CATALOGUE DE PIECES DETACHEES
©2002 Yamaha Motor Co., Ltd.
1ère Edition, Mai 2002
Tous droits réservés.
Toute réimpression ou utilisation
sans la permission écrite de la
Yamaha Motor Co., Ltd.
est formellement interdite.