

**PARTS
CATALOGUE
CATALOGO
DE REPUESTOS**

E25B '01 (69P1)

25B '01 (69R1)

30H '01 (69S1)

FOREWORD

This Parts Catalogue is related to the parts for the model(s) in the below frame. When you are ordering replacement parts, please refer to this Parts Catalogue and quote both part numbers and part names correctly.

E25B'01(69P1), 25B'01(69R1), 30H'01(69S1)

1. Modifications or additions which have been made after issue of the Parts Catalogue will be announced in the Yamaha Parts News.
It is advisable that you make necessary corrections to the Parts Catalogue according to the Yamaha Parts News.

2. Abbreviations

The Following abbreviations are used in this Parts Catalogue.

- "UR" Use specified parts number.
- "UN" Use as many as needed.
- "AP" Alternate Parts
- "LM" Local Made
(Parts need to be ordered locally)
- "O/S" Over Size

3. Parts, which are to be supplied in an assembly, are listed with a dot(.) in front of the part name as shown below.

EXAMPLE
 CARBURETOR ASSY
 .JET, PILOT
 .NOZZLE, MAIN

4. Number of component for assembly

The numeral appearing to the right of each component part indicates the quantity of parts for each assembly unit.

EXAMPLE

PART NO.	DESCRIPTION	U	H	HT	REMARKS
6E0-85500-70	C.D.I. MAGNETO ASSY	1			
6E0-85550-70	.ROTOR ASSY	1			
6E0-15723-00-94.	.PULLY, STARTER	1			

5. Quantity Column Information

NAME for Q'TY COLUMN	APPLICABLE MODEL
MH	E25BMH, 25BMH, 30HMH
WH	30HWH
W	25BW, 30HW

6. Applicable Starting Serial No. and Color Code

1) Engine Starting Serial No.

E25BMH	S : 160101 L : 460101 X : 810101	25BW	L : 410101
25BMH	S : 020101 L : 350101 X : 710101	30HW	S : 150101 L : 450101
30HMH	S : 050101 L : 500101	30HWH	L : 550101

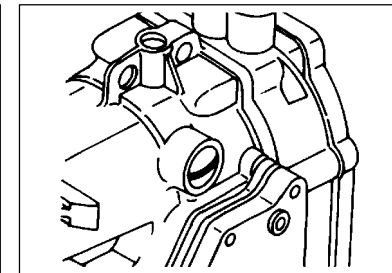
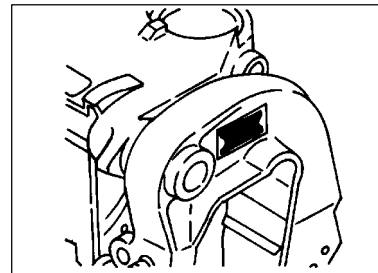

2) Color Code

Color Code	Color Name	Abbreviation
004D	DARK BLUISH GRAY METALLIC 2	DBNM2

7. Note that the illustrations for reference in finding parts numbers, not to be used for assembling. When assembling, please use the applicable service manual.

8. The asterisk (*) before a reference number indicates modification items after the first edition.

CONTENTS

SHEET 1/2

TOP COWLING	A4
CYLINDER, CRANKCASE	A5
CRANKSHAFT, PISTON	A7
INTAKE	B1
CARBURETOR	B2
FUEL	B4
STARTER	B6
GENERATOR	C1
ELECTRICAL 1	C2
ELECTRICAL 2	C4
ELECTRICAL 3	C5
STARTING MOTOR	C7
BOTTOM COWLING	D1
STEERING	D2
CONTROL 1	D3
CONTROL 2	D5
BRACKET 1	D6
BRACKET 2	E1
UPPER CASING	E3
LOWER CASING, DRIVE 1	E5
LOWER CASING, DRIVE 2	F2
FUEL TANK	F3
STEERING GUIDE	F4
REMOTE CONTROL BOX	F5
REMOTE CONTROL ASSY	F6

INDEX

NUMERICAL INDEX	G1
-----------------------	----

SHEET 2/2

REMOTE CONTROL ASSY	A4*
REPAIR KIT 1	A5*
REPAIR KIT 2	A6*

INDEX

NUMERICAL INDEX	G1*
-----------------------	-----

FIG. 1 TOP COWLING

SOPORTE SUPERIOR

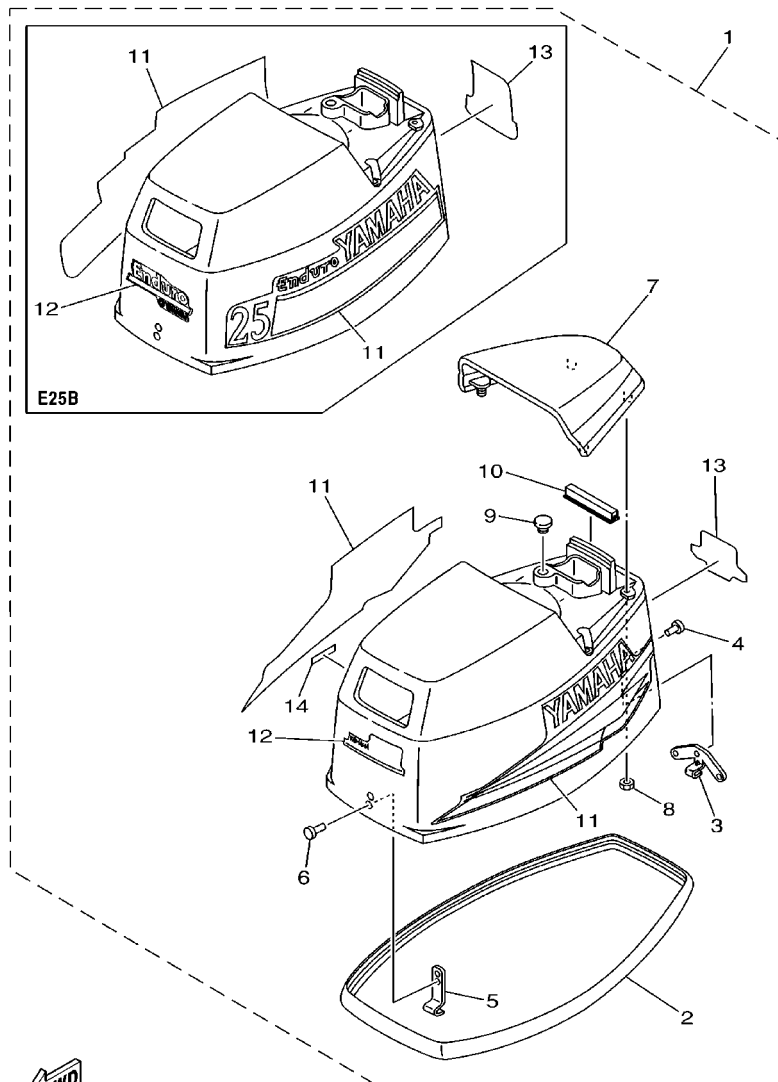

REF. NO.	PART NO. CODIGO NO.	DESCRIPTION DESCRIPTION	MH	WH	W	REMARKS OBSERVACION
1	69R-42610-10-4D	TOP COWLING ASSY SOPORTE SUPERIOR COMPL.	1		1	25B
	69S-42610-10-4D	TOP COWLING ASSY SOPORTE SUPERIOR COMPL.	1	1	1	30H
	69P-42610-H0-4D	TOP COWLING ASSY SOPORTE SUPERIOR COMPL.	1			E25B
2	6G0-42615-00	.SEAL .SELLO	1	1	1	
3	689-42647-00	.HOLDER, CLAMP BAND .MORDAZA DE ABRAZADERA	1	1	1	
4	90266-04M01	.RIVET .REMACHE	3	3	3	
5	6G0-42651-02	.HOOK .GANCHO	1	1	1	
6	90266-04M00	.RIVET .REMACHE	2	2	2	
7	69P-42613-00-4D	MOLDING, AIR DUCT .MOLDURA CONDUCTO AIRE	1	1	1	
8	90179-06M24	.NUT .TUERCA	4	4	4	
9	90480-14M14	.GROMMET .TAPON	1	1	1	
10	61N-42628-00	.SEAL .SELLO DE GOMA	1	1	1	
11	61R-W0070-10	.GRAPHIC SET .JUEGO DE EMBLEMA	1	1	1	25B,30H
	61N-W0070-H0	.GRAPHIC SET .JUEGO DE EMBLEMA	1			E25B
12	61R-42677-10	.GRAPHIC, FRONT .CALCAMONIA FRONTAL	1		1	25B
	61T-42677-10	.GRAPHIC, FRONT .CALCAMONIA FRONTAL	1	1	1	30H
	69P-42677-H0	.GRAPHIC, FRONT .CALCAMONIA FRONTAL	1			E25B
13	61R-42678-10	.GRAPHIC, REAR .CALCAMONIA TRASERA	1		1	25B
	61T-42678-10	.GRAPHIC, REAR .CALCAMONIA TRASERA	1	1	1	30H
	61N-42678-H0	.GRAPHIC, REAR .CALCAMONIA TRASERA	1			E25B
14	6E0-44191-11	.INDICATOR, SHIFT .INDICADOR DE CAMBIOS	1	1	1	25B,30H

FWD
69R0200-1010

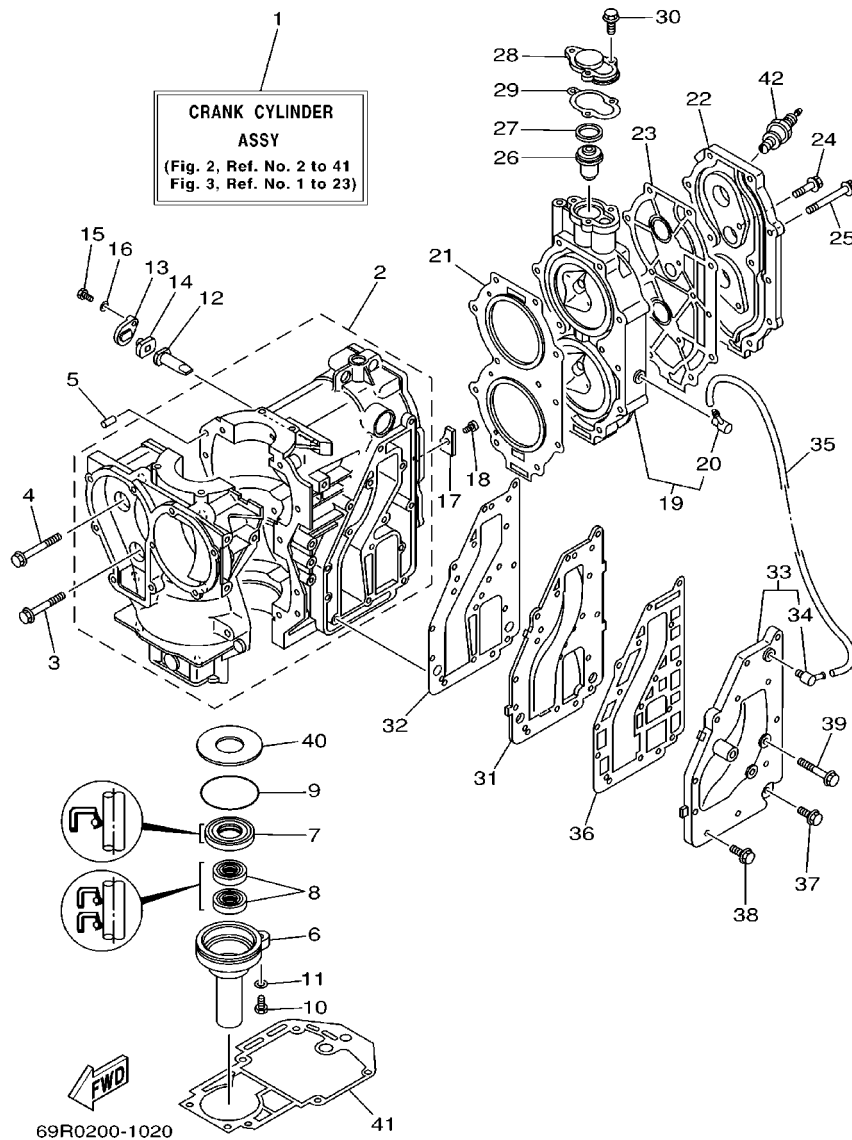

FIG. 2 CYLINDER, CRANKCASE CYLINDRO, CARTER

REF. NO.	PART NO. CODIGO NO.	DESCRIPTION DESCRIPTION	MH	WH	W	REMARKS OBSERVACION
1	69P-W0090-00-1S	CRANK CYLINDER ASSY BLOQUE MOTOR COMPLETO	1		1	E25B,25B
	69S-W0090-00-1S	CRANK CYLINDER ASSY BLOQUE MOTOR COMPLETO	1	1	1	30H
2	69P-15100-00-1S	CRANKCASE ASSY CARTER COMPLETO	1	1	1	
3	90119-08009	BOLT, WITH WASHER TORNILLO CON ARANDELA	2	2	2	
4	90119-08M65	BOLT, WITH WASHER TORNILLO CON ARANDELA	8	8	8	
5	93606-12019	PIN, DOWEL PASADOR DE CLAVIJA	2	2	2	
6	689-15396-01-5B	HOUSING, OIL SEAL CAJA DE SELLO DE ACEITE	1	1	1	
7	93102-25008	OIL SEAL SELLO ACEITE	1	1	1	
8	93101-16001	OIL SEAL SELLO ACEITE	2	2	2	
9	93210-58M21	O-RING ANILLO O	1	1	1	
10	97095-06022	BOLT PERNO	1	1	1	
11	92995-06600	WASHER ARANDELA	1	1	1	
12	6J8-11325-00	ANODE ANODO	1	1	1	
13	6H3-11327-00-94	COVER, ANODE CUBIERTA	1	1	1	
14	6H3-11328-00	GROMMET, ANODE TAPON	1	1	1	
15	97013-06016	BOLT PERNO	1	1	1	
16	92903-06600	WASHER, PLATE ARANDELA	1	1	1	
17	689-11325-00	ANODE ANODO	1	1	1	
18	90151-06M02	SCREW, COUNTERSUNK TORNILLO EMBUTIDO	1	1	1	
19	61N-11111-01-1S	HEAD, CYLINDER 1 CULATA CILINDRO 1	1		1	E25B,25B
	61T-11111-01-1S	HEAD, CYLINDER 1 CULATA CILINDRO 1	1	1	1	30H
20	676-11372-00	NIPPLE, HOSE NIPLE DE MANGUERA	1	1	1	
21	61N-11181-A1	GASKET, CYLINDER HEAD 1 JUNTA, DE CULATA 1	1	1	1	
22	61N-11191-01-1S	COVER, CYLINDER HEAD 1 TAPA CULATA DE CILINDRO 1	1	1	1	
23	61N-11193-02	GASKET, HEAD COVER 1 EMPAQUE	1	1	1	
24	90119-06MA2	BOLT, WITH WASHER TORNILLO CON ARANDELA	2	2	2	
25	90119-08015	BOLT, WITH WASHER TORNILLO CON ARANDELA	11	11	11	

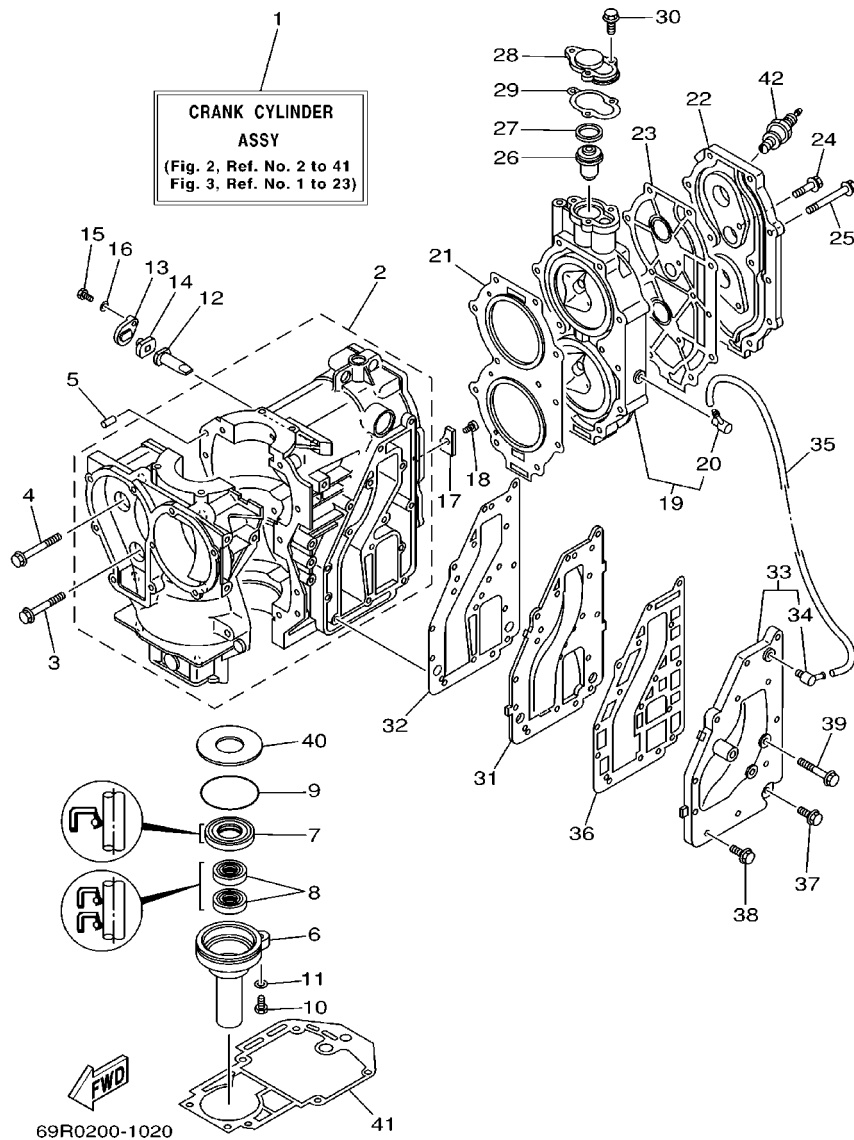
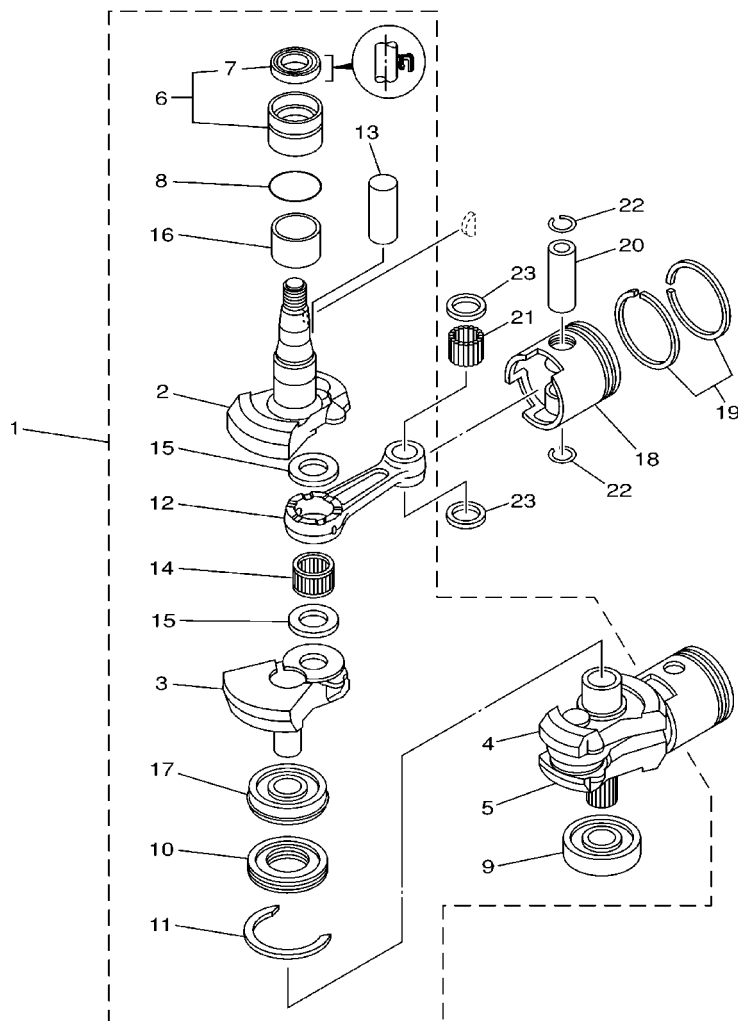

FIG. 2 CYLINDER, CRANKCASE CYLINDRO, CARTER

REF. NO.	PART NO. CODIGO NO.	DESCRIPTION DESCRIPTION	MH	WH	W	REMARKS OBSERVACION
26	6E5-12411-01	THERMOSTAT TERMOSTAT	1	1	1	
27	90201-21567	WASHER, PLATE ARANDELA PLANA	1	1	1	
28	655-12413-01-1S	COVER, THERMOSTAT CUBIERTA TERMOSTATO	1	1	1	
29	655-12414-00	GASKET, COVER EMPAQUE	1	1	1	
30	90119-06MA2	BOLT, WITH WASHER TORNILLO CON ARANDELA	3	3	3	
31	6K8-41121-00-1S	INNER COVER, EXHAUST CUBIERTA INTERIOR DE ESCAPE	1	1	1	
32	6K8-41122-A1	GASKET, EXHAUST INNER COVER EMPAQUE	1	1	1	
33	61N-41123-00-1S	OUTER COVER, EXHAUST CUBOERTA EXTERIOR DE ESCAPE	1	1	1	
34	676-11372-00	.NIPPLE, HOSE .NIPLE DE MANGUERA	1	1	1	
35	90445-10M41	HOSE (L105) TUBO (L105)	1	1	1	
36	6K8-41124-A1	GASKET, EXHAUST OUTER COVER EMPAQUE	1	1	1	
37	90119-06MA3	BOLT, WITH WASHER TORNILLO CON ARANDELA	1	1	1	
38	90119-06MA4	BOLT, WITH WASHER TORNILLO CON ARANDELA	11	11	11	
39	90119-06MA0	BOLT, WITH WASHER TORNILLO CON ARANDELA	3	3	3	
40	90201-50306	WASHER, PLATE ARANDELA PLANA	1	1	1	
41	689-45113-A1	GASKET, UPPER CASING EMPAQUE	1	1	1	
42	94702-00217	PLUG, SPARK (NGK B7HS-10) BUJIA (NGK B7HS-10)	2	2	2	E25B,25B
	94702-00160	PLUG, SPARK (NGK B8HS-10) BUJIA (NGK B8HS-10)	2	2	2	30H
	94702-00271	PLUG, SPARK (NGK BR7HS-10) BUJIA (NGK BR7HS-10)	2			E25B,25B-FOR CARIB
	94702-00247	PLUG, SPARK (NGK BR8HS-10) BUJIA (NGK BR8HS-10)	2	2	2	30H-FOR CARIB, CHINA

FIG. 3 CRANKSHAFT. PISTON

CIGUENAL. PISTON



REF. NO.	PART NO. CODIGO NO.	DESCRIPTION DESCRIPTION	MH	WH	W	REMARKS OBSERVACION
1	69P-11400-00	CRANKSHAFT ASSY CIGUENAL COMPLETO	1	1	1	
2	69P-11412-00	.CRANK 1 .MANIVELA 1	1	1	1	
3	61N-11422-00	.CRANK 2 .MANIVELA 2	1	1	1	
4	61N-11432-00	.CRANK 3 .MANIVELA 3	1	1	1	
5	61N-11442-00	.CRANK 4 .MANIVELA 4	1	1	1	
6	93399-99951	.BEARING .COJINETE	1	1	1	
7	93102-32M07	..OIL SEAL ..SELLO ACEITE	1	1	1	
8	93210-46M16	.O-RING .ANILLO O	1	1	1	
9	93306-305U3	.BEARING .COJINETE	1	1	1	
10	61N-11515-00	.SEAL, LABYRINTH 1 .SELLO LABERINTO 1	1	1	1	
11	93440-62057	.CIRCLIP .BOLA	1	1	1	
12	689-11651-00	.ROD, CONNECTING .BIELA	2	2	2	
13	689-11681-01	.PIN, CRANK 1 .PASADOR MANIVELA 1	2	2	2	
14	93310-62406	.BEARING .COJINETE	2	2	2	
15	90209-24M03	.WASHER .ARANDELA DE SEPARACION	4	4	4	
16	90387-32002	.COLLAR .COLLAR	1	1	1	
17	93390-00009	.BEARING .COJINETE	1	1	1	
18	61N-11631-00-95	PISTON (STD) PISTON (STD)	2	2	2	
	61N-11635-00	PISTON (0.25MM O/S)	2	2	2	AP
	61N-11636-00	PISTON (0.50MM O/S)	2	2	2	AP
	61N-11636-00	PISTON (0.50MM O/S)	2	2	2	AP
19	61N-11603-00	PISTON RING SET (STD) JUEGO DE ANILLOS (STD)	2	2	2	
	61N-11604-00	PISTON RING SET (0.25MM O/S) JUEGO DE ANILLOS (0.25MM O/S)	2	2	2	AP
	61N-11605-00	PISTON RING SET (0.50MM O/S) JUEGO DE ANILLOS (0.50MM O/S)	2	2	2	AP
20	689-11633-00	.PIN, PISTON .PASADOR, PISTON	2	2	2	
21	93602-20M02	.PIN, DOWEL .PASADOR DE CLAVIJA	68	68	68	
22	688-11634-00	.CLIP, PISTON PIN .PRESILLA, BULON DE PISTON	4	4	4	
23	90201-20M27	.WASHER, PLATE .ARANDELA PLANA	4	4	4	

69R0010-1030

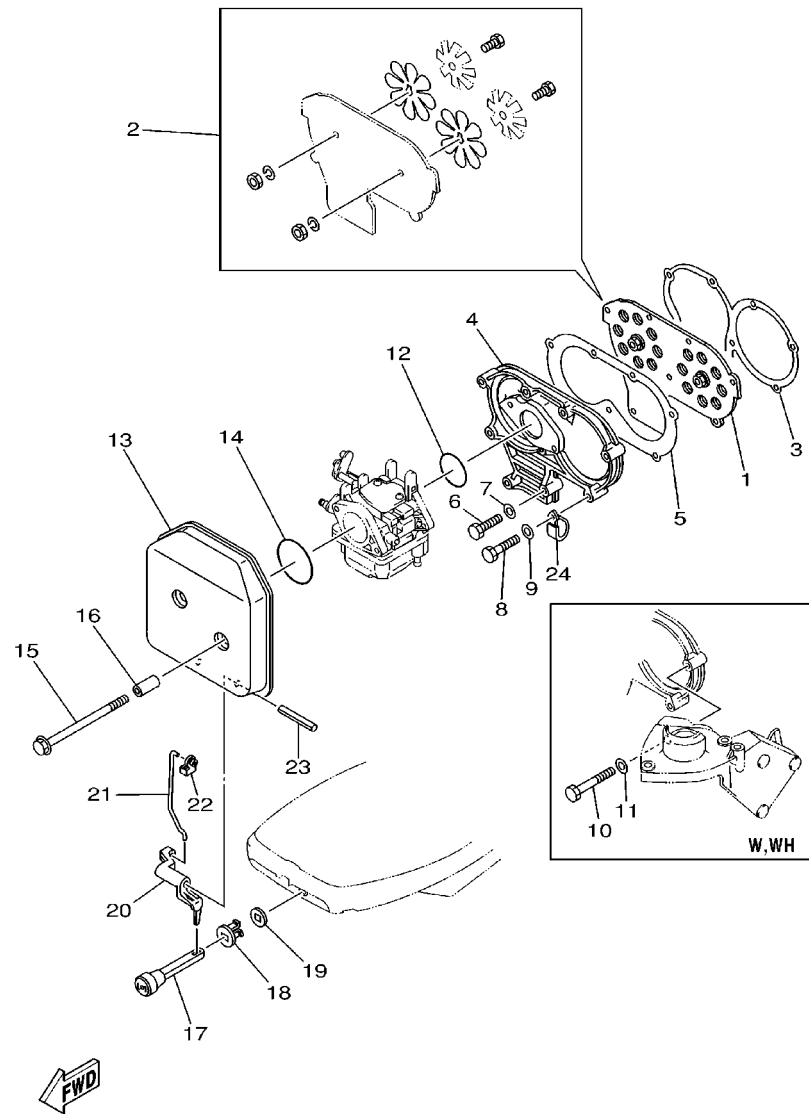

69R0200-1040

FIG. 4 INTAKE

ADMISION

REF. NO.	PART NO. CODIGO NO.	DESCRIPTION DESCRIPTION	MH	WH	W	REMARKS OBSERVACION
1	61N-13610-00	REED VALVE ASSY VALVULA DE LAMINAS COMPLETA	1		1	E25B,25B
	689-13610-01	REED VALVE ASSY VALVULA DE LAMINAS COMPLETA	1	1	1	30H
2	689-W0004-00	.REED SET .JUEGO DE VALVULAS DE LENGUETA	1	1	1	
3	648-13621-01	GASKET, VALVE SEAT JUNTA, DE VALV.DE EMPAQUE	1	1	1	
4	61N-13641-01-1S	MANIFOLD 1 MULTIPLE 1	1	1	1	
5	648-13645-00	GASKET, MANIFOLD 1 EMPAQUE	1	1	1	
6	97013-06025	BOLT PERNO	2	2	2	
7	92903-06600	WASHER, PLATE ARANDELA	2	2	2	
8	97013-06035	BOLT PERNO	7			
	97013-06035	BOLT PERNO	6	6		
9	92903-06600	WASHER, PLATE ARANDELA	7			
	92903-06600	WASHER, PLATE ARANDELA	6	6		
10	97013-06050	BOLT PERNO	1	1		
11	92903-06600	WASHER, PLATE ARANDELA	1	1		
12	61N-14198-00	GASKET EMPAQUE	1	1	1	
13	61N-14440-00	SILENCER ASSY, INTAKE SILENCIADOR COMPL DE ADMISION	1	1	1	
14	93210-40659	O-RING ANILLO O	1	1	1	
15	90119-06M94	BOLT, WITH WASHER TORNILLO CON ARANDELA	2	2	2	
16	90387-06M26	COLLAR COLLAR	2	2	2	
17	682-41271-00	KNOB, CHOKE PERILLA AHOGADOR	1	1	1	
18	689-41273-00	GROMMET TAPON PROTECTOR	1	1	1	
19	6J8-41274-00	GROMMET 2 TAPON 2	1	1	1	
20	689-41252-01	LEVER, CHOKE 1 PALANCA AHOGADOR 1	1	1	1	
21	61N-41256-00	ROD, CHOKE 1 VARILLA DE AHOGADOR	1	1	1	
22	661-41262-02	JOINT, CHOKE LEVER CONECTOR DE AHOGADOR	1	1	1	
23	91690-40048	PIN, SPRING PASADOR DE RESORTE	1	1	1	
24	90465-06M88	CLAMP BRIDA	1	1	1	

B1

FIG. 5 CARBURETOR

CARBURADOR

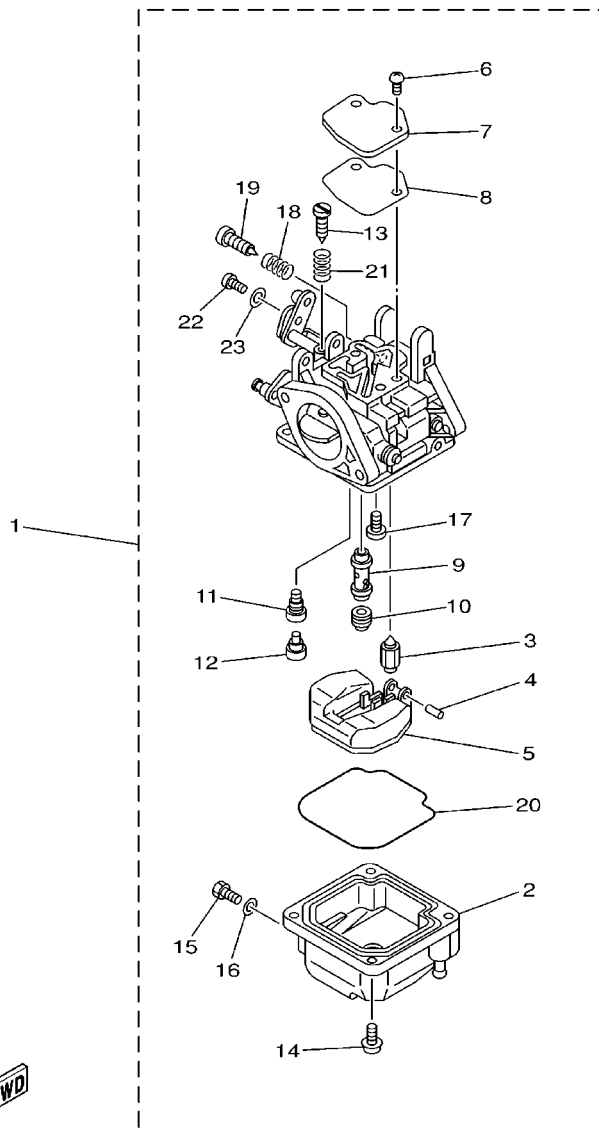

69R0010-1050

REF. NO.	PART NO. CODIGO NO.	DESCRIPTION DESCRIPTION	MH	WH	W	REMARKS OBSERVACION
1	69P-14301-00	CARBURETOR ASSY 1 CARBURADOR COMPLETO 1	1		1	E25B,25B
	69S-14301-00	CARBURETOR ASSY 1 CARBURADOR COMPLETO 1	1	1	1	30H
	69P-14301-10	CARBURETOR ASSY 1 CARBURADOR COMPLETO 1	1			E25B-FOR BRAZIL
	69S-14301-10	CARBURETOR ASSY 1 CARBURADOR COMPLETO 1	1	1		30H-FOR BRAZIL
2	61N-14381-00	.BODY, FLOAT CHAMBER .CUERPO DE CAMARA DE BOIA	1	1	1	
3	61N-14392-00	.VALVE, NEEDLE .VALVULA DE AGUJA	1	1	1	
4	6E5-14386-01	.PIN, FLOAT .PASADOR DE BOIA	1	1	1	
5	6L2-14385-00	.FLOAT .BOIA	1	1	1	
6	97980-04110	.SCREW, WITH WASHER .TORNILLO, CON ARANDELA	2	2	2	
7	6L2-14157-00	.COVER, MIXING .CUBIERTA DE MEZCLA	1	1	1	
8	6L2-14399-00	.GASKET .EMPAQUE	1	1	1	
9	61N-14341-00	.NOZZLE, MAIN .BOQUILLA PRINCIPAL	1	1	1	E25B,25B
	61T-14341-00	.NOZZLE, MAIN .BOQUILLA PRINCIPAL	1	1	1	30H
10	61N-14343-65	.JET, MAIN (#130) .INYECTOR PRINCIPAL (#130)	1	1	1	
	61N-14343-68	.JET, MAIN (#135) .INYECTOR PRINCIPAL (#135)	1			E25B-FOR BRAZIL
	61N-14343-70	.JET, MAIN (#140) .INYECTOR PRINCIPAL (#140)	1	1	1	30H-FOR BRAZIL
11	6L2-14342-34	.JET, PILOT (#68) .ESPREA DE PILOTO (#68)	1	1	1	
	6L2-14342-36	.JET, PILOT (#72) .ESPREA DE PILOTO (#72)	1	1	1	FOR BRAZIL
12	50M-14355-00	.PLUG .TAPON	1	1	1	
13	664-14321-01	.SCREW, THROTTLE .TORNILLO DE OBTURADOR	1	1	1	
14	97980-04112	.SCREW, WITH WASHER .TORNILLO, CON ARANDELA	4	4	4	
15	677-14383-01	.SCREW, DRAIN .TORNILLO DE DRENAJE	1	1	1	
16	6L2-14398-00	.GASKET .EMPAQUE	1	1	1	
17	98980-04006	.SCREW, BIND .TORNILLO DE LIGAR	2	2	2	
18	646-14212-01	.SPRING, PILOT ADJUSTING .RESORTE DE AJUSTE DE PILOTO	1	1	1	
19	61N-14323-00	.SCREW, AIR ADJUSTING .TORNILLO DE AJUSTE DE AIRE	1	1	1	
20	6L2-14384-00	.GASKET, FLOAT CHAMBER .EMPAQUE DE CAMARA DE BOIA	1	1	1	

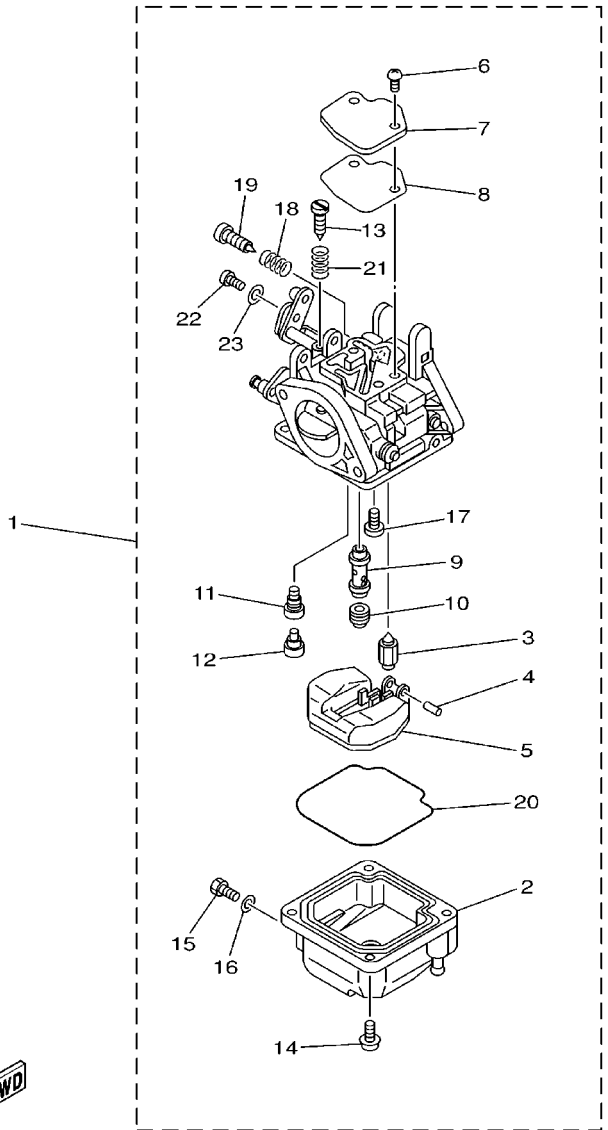



69R0010-1050

FIG. 5 CARBURETOR CARBURADOR

REF. NO.	PART NO. CODIGO NO.	DESCRIPTION DESCRIPTION	MH	WH	W	REMARKS OBSERVACION
21	61N-14212-00	.SPRING, PILOT ADJUSTING .RESORTE DE AJUSTE DE PILOTO	1	1	1	
22	97890-05006	.SCREW, PAN HEAD .TORNILLO DE CABEZA CON PLANA	1	1	1	
23	62Y-14597-00	.WASHER .ARANDELA	1	1	1	

FIG. 6 FUEL

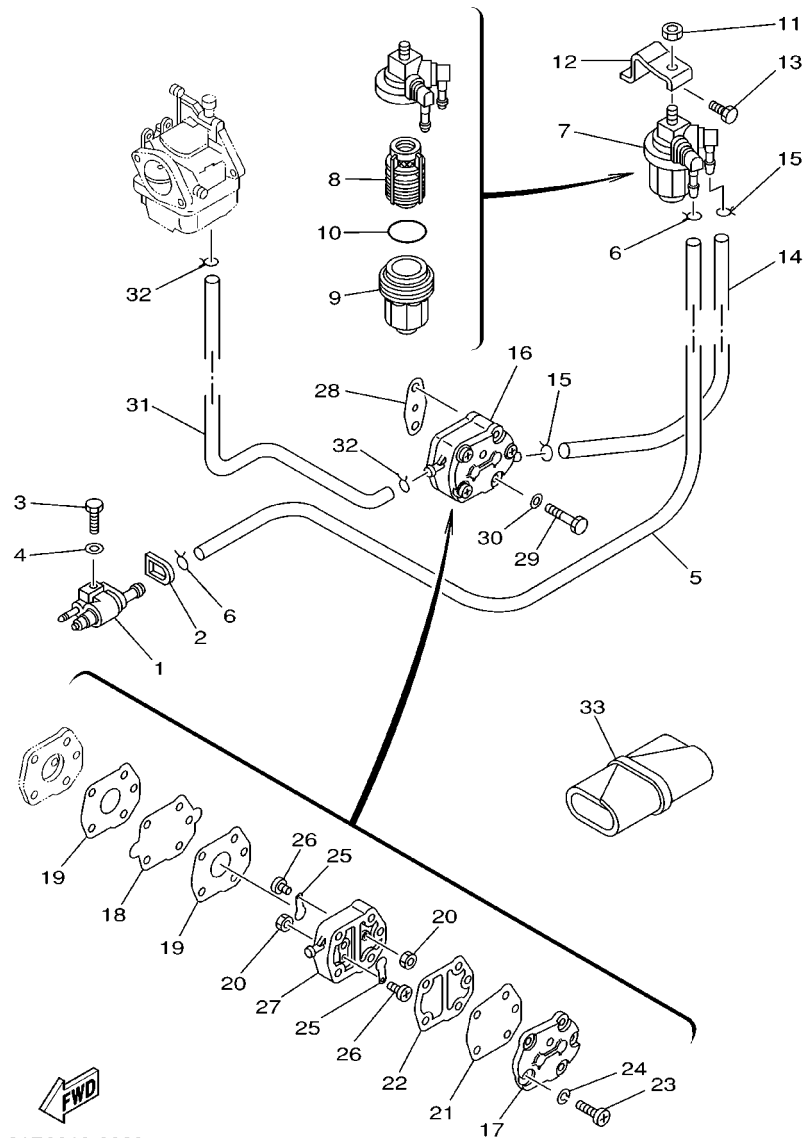
COMBUSTIBLE



61R0010-0060

REF. NO.	PART NO. CODIGO NO.	DESCRIPTION DESCRIPTION	MH	WH	W	REMARKS OBSERVACION
1	6G1-24304-02	FUEL PIPE JOINT COMP. 1 CONECTOR MANGUERA COMBUST.1	1	1	1	
2	61N-24329-00	SEAL SELLO	1	1	1	
3	97095-06020	BOLT PERNO	1	1	1	
4	92995-06600	WASHER ARANDELA	1	1	1	
5	90445-09M75	HOSE (L370) TUBO (L370)	1	1	1	
6	90467-08004	CLIP PRESILLA	2	2	2	
7	61N-24560-00	FILTER ASSY FILTRO COMPLETO	1	1	1	
8	61N-24563-00	.ELEMENT, FILTER .ELEMENTO DEL FILTRO	1	1	1	
9	61N-24521-00	.CUP, FILTER .COPA DE FILTRO	1	1	1	
10	93210-32738	.O-RING .ANILLO O	1	1	1	
11	95380-08600	NUT TUERCA	1	1	1	
12	61N-24566-01	BRACKET, FILTER SOPORTE DEL FILTRO	1	1	1	
13	97013-06014	BOLT PERNO	1	1	1	
14	689-24311-00	PIPE, FUEL 1 TUBO DE COMBUSTIBLE 1	1	1	1	
15	90467-08004	CLIP PRESILLA	2	2	2	
16	692-24410-00	FUEL PUMP ASSY BOMBA DE COMBUSTIBLE COMPLETA	1	1	1	
17	6A0-24413-00	.BODY 2 .CUERPO 2	1	1	1	
18	692-24411-00	.DIAPHRAGM .DIAFRAGMA	1	1	1	
19	648-24434-01	.GASKET, BODY .EMPAQUE	2	2	2	
20	95380-03600	.NUT .TUERCA	2	2	2	
21	663-24411-00	.DIAPHRAGM .DIAFRAGMA	1	1	1	
22	648-24435-02	.GASKET, BODY 2 .EMPAQUE	1	1	1	
23	98503-05028	.SCREW, PAN HEAD .TORNILLO DE CABEZA CON PLANA	3	3	3	
24	92990-05100	.WASHER, SPRING .ARANDELA	3	3	3	
25	6A0-24421-01	.VALVE, CHECK .VALVULA DE RETENCION	2	2	2	
26	6A0-14325-00	.SCREW, PAN HEAD .TORNILLO CABEZA REDONDA	2	2	2	
27	6A0-24412-02	.BODY 1 .CUERPO 1	1	1	1	

FIG. 6 FUEL

COMBUSTIBLE

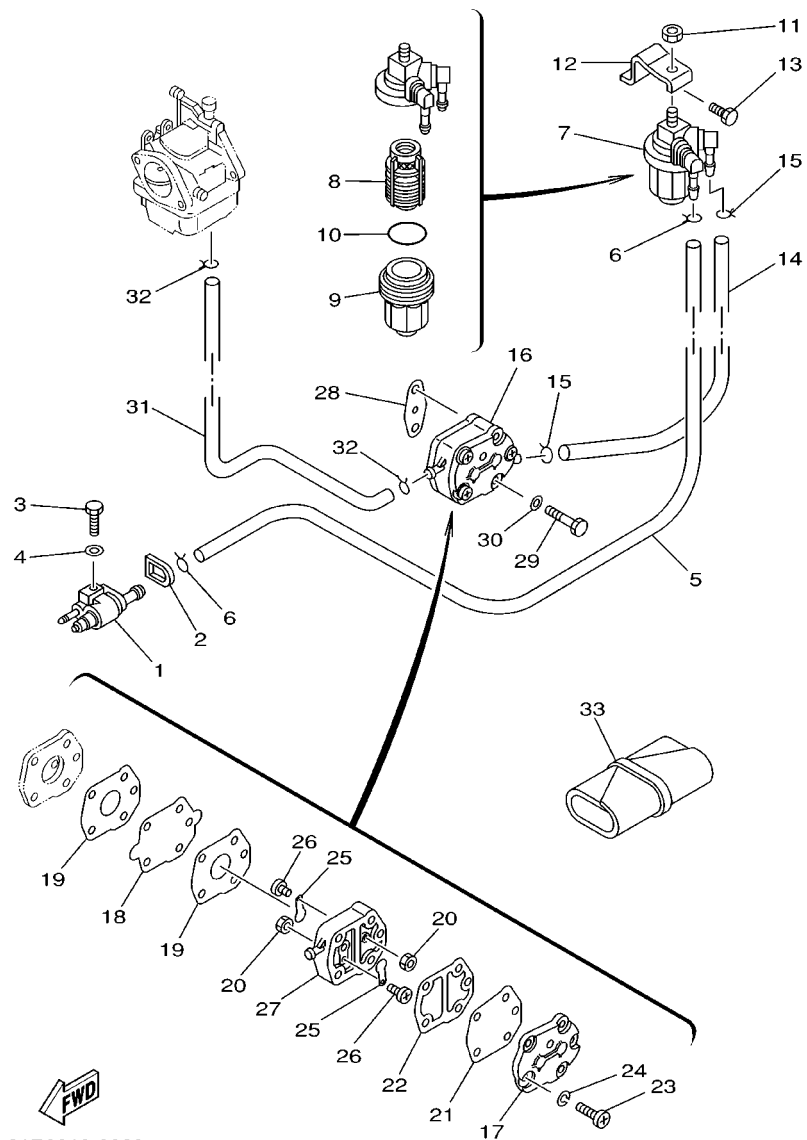

61R0010-0060

REF. NO.	PART NO. CODIGO NO.	DESCRIPTION DESCRIPTION	MH	WH	W	REMARKS OBSERVACION
28	650-24431-A0	GASKET, FUEL PUMP 1 EMPAQUE BOMBA COMBUST 1	1	1	1	
29	97095-06040	BOLT PERNO	2	2	2	
30	92995-06600	WASHER ARANDELA	2	2	2	
31	6A1-24311-00	PIPE, FUEL 1 TUBO DE COMBUSTIBLE 1	1	1	1	
32	90467-08004	CLIP PRESILLA	2	2	2	
33	656-W2810-02	TOOL KIT JUEGO DE HERRAMIENTAS	1	1	1	
<hr/>						
<hr/>						
<hr/>						
<hr/>						
<hr/>						
<hr/>						
<hr/>						

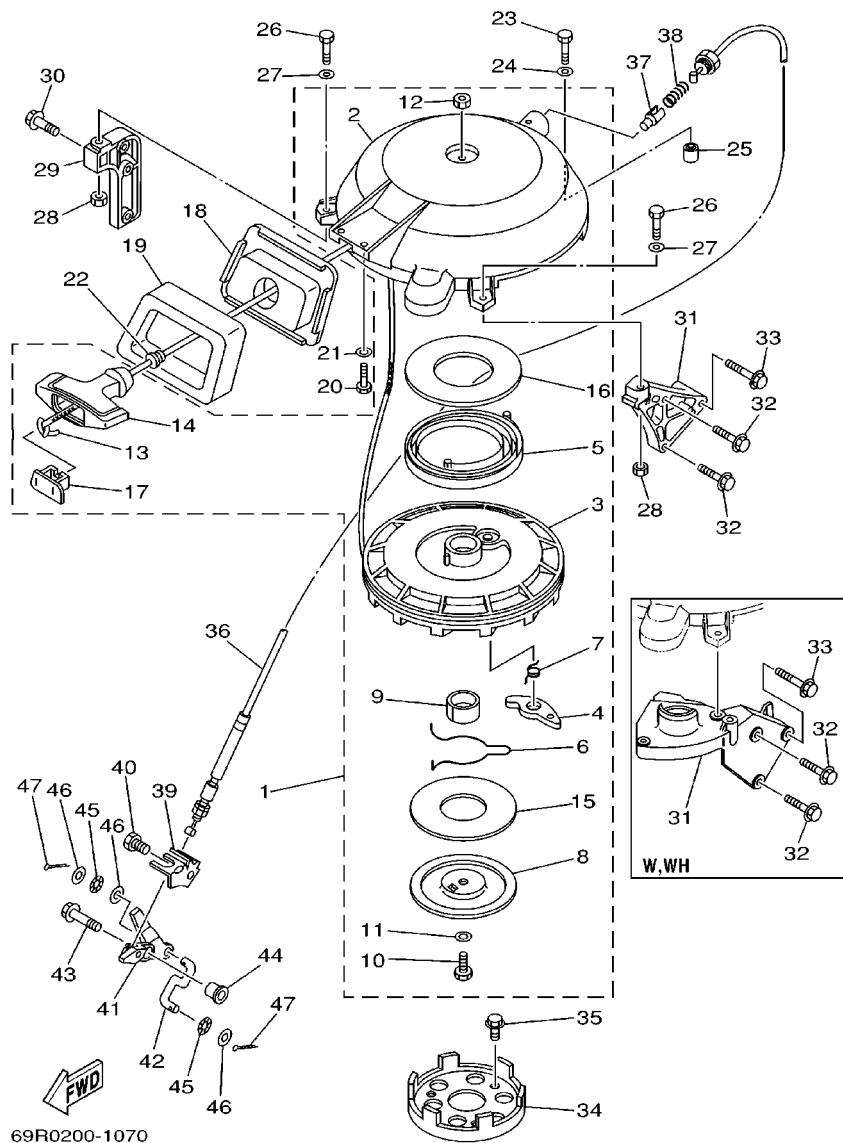

69R0200-1070

FIG. 7 STARTER

ARRANQUE

REF. NO.	PART NO. CODIGO NO.	DESCRIPTION DESCRIPTION	MH	WH	W	REMARKS OBSERVACION
1	61N-W1571-11	STARTER ASSY ARRANQUE COMPLETO	1	1	1	
2	61N-15711-10	.CASE, STARTER .CAJA DE ARRANQUE	1	1	1	
3	6G0-15714-01	.DRUM, SHEAVE .TAMBOR ROLDANA	1	1	1	
4	6F5-15741-01	.PAWL, DRIVE .TRINQUETE DE TRACCION	1	1	1	
5	6F5-15713-01	.SPRING, STARTER .RESORTE DE ARRANQUE	1	1	1	
6	61N-15715-00	.SPRING, FRICTION .RESORTE PLACA DE TRACCION	1	1	1	
7	61N-15734-00	.SPRING, RETURN .RESORTE DE RETORNO	1	1	1	
8	6F5-15716-01	.PLATE, DRIVE .PLACA DE TRACCION	1	1	1	
9	6G0-15754-00	.BUSH 2 .BUJE	1	1	1	
10	97313-08030	.BOLT .PERNO	1	1	1	
11	6F5-15726-01	.WASHER, FLAT .ARANDELA PLANA	1	1	1	
12	95303-08700	.NUT .TUERCA	1	1	1	
13	*	.WIRE (L:1900MM) .CABLE (L:1900MM)	1	1	1	
14	689-15755-01	.HANDLE, STARTER .MANIJA DE ARRANQUE	1	1	1	
15	6F5-15764-00	.COLLAR 1 .COLLAR 1	1	1	1	
16	6F5-15739-00	.WASHER, THRUST .ARANDELA DE EMPUJE AXIAL	1	1	1	
17	6F5-15779-02	.COVER .CUBIERTA	1	1	1	
18	61N-15758-01-4D	.GUIDE, ROPE .GUIA DE CUERDA	1	1	1	
19	61N-15762-00	.SEAL, RUBBER 2 .SELLO DE GOMA 2	1	1	1	
20	97095-06016	.BOLT .PERNO	2	2	2	
21	92995-06600	.WASHER .ARANDELA	2	2	2	
22	6A0-15789-00	.DAMPER .AMORTIGUADOR	1	1	1	
23	97095-06035	.BOLT .PERNO	1	1	1	
24	92995-06600	.WASHER .ARANDELA	1	1	1	
25	99530-10014	.PIN, DOWEL .PASADOR, DE ESPIGA	1	1	1	
<p>* CUT FROM 50M ROLLS, PART NO. 90890-44373, CUTTING LENGTH 1.9M * CORTE DE UN RODILLO DE 50M, PARTS NUMERO 90890-44373, LARGO DEL CORTE 1.9M</p>						

B6

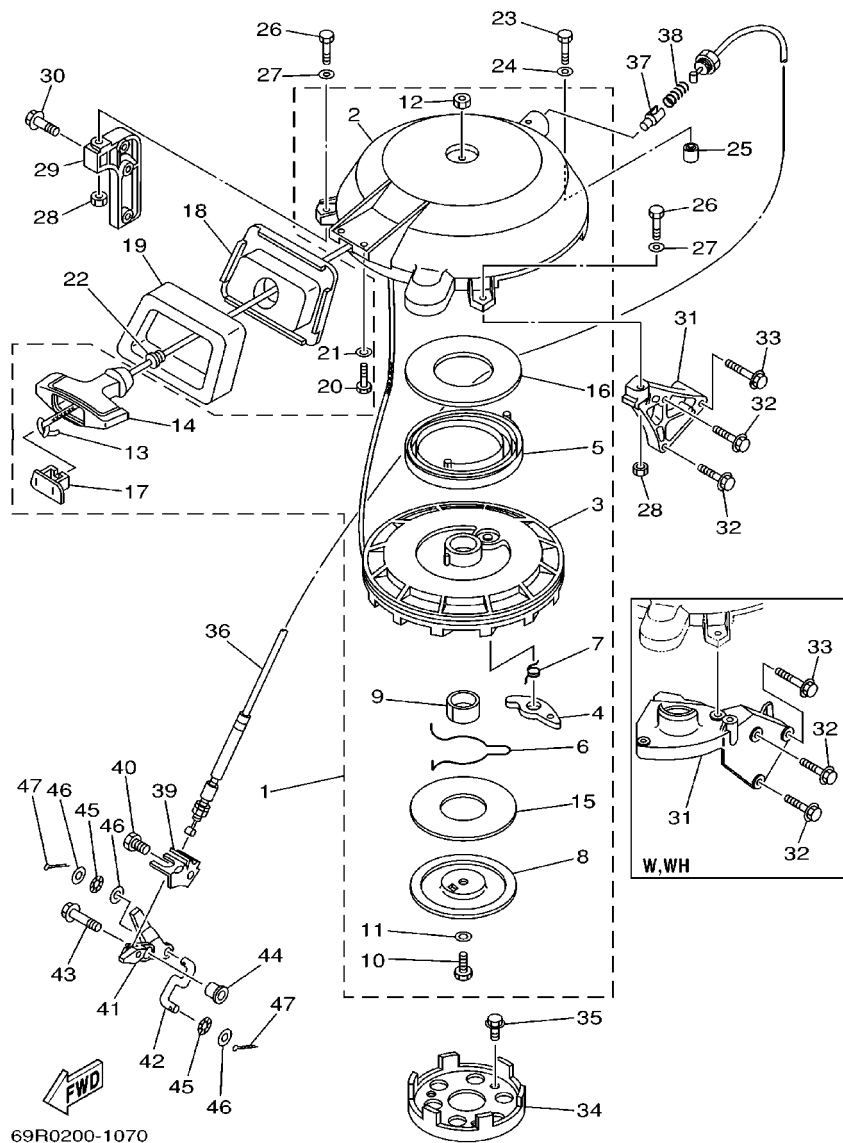

69R0200-1070

FIG. 7 STARTER

ARRANQUE

REF. NO.	PART NO. CODIGO NO.	DESCRIPTION DESCRIPTION	MH	WH	W	REMARKS OBSERVACION
26	97095-06035	BOLT PERNO	2	2	2	
27	92995-06600	WASHER ARANDELA	2	2	2	
28	95380-06600	NUT, HEXAGON TUERCA	2			
	95380-06600	NUT, HEXAGON TUERCA		1	1	
29	6H7-15771-01-94	STAY 1 SOPORTE 1	1	1	1	
30	90119-06MA3	BOLT, WITH WASHER TORNILLO CON ARANDELA	2	2	2	
31	656-15772-00-94	STAY 2 SOPORTE 2	1			
	61T-15772-01-94	STAY 2 SOPORTE 2		1	1	
32	90119-06MA3	BOLT, WITH WASHER TORNILLO CON ARANDELA	2			
	90119-06MA4	BOLT, WITH WASHER TORNILLO CON ARANDELA		2	2	
33	90119-06025	BOLT, WITH WASHER TORNILLO CON ARANDELA	1	1	1	
34	6F5-15723-01	PULLEY, STARTER POLEA DE ARRANQUE	1	1	1	
35	90105-08M10	BOLT, WASHER BASED TORNILLO CON ARANDELA	3	3	3	
36	61T-15770-00	CABLE COMP., STARTER STOP CABLECOMPL DE SEGURO ARRANQUE	1	1	1	
37	656-15748-00	PLUNGER, STARTER STOP EMBOLO SEGURO DE ARRANQUE	1	1	1	
38	90501-10227	SPRING, COMPRESSION RESORTE DE COMPRESION	1	1	1	
39	69P-15774-00	STAY 4 SOPORTE 4	1	1	1	
40	97095-06010	BOLT PERNO	1	1	1	
41	69P-15746-00	ARM BRAZO	1	1	1	
42	689-15747-70	LINK ESLABON	1	1	1	
43	90119-06M23	BOLT, WITH WASHER TORNILLO CON ARANDELA	1	1	1	
44	90387-06013	COLLAR COLLAR	1	1	1	
45	90206-05005	WASHER, WAVE ARANDELA ONDULADA	2	2	2	
46	92903-05600	WASHER, PLATE ARANDELA	3	3	3	
47	91490-16010	PIN, COTTER PASADOR DE CHAVETA	2	2	2	

FIG. 8 GENERATOR

GENERADOR

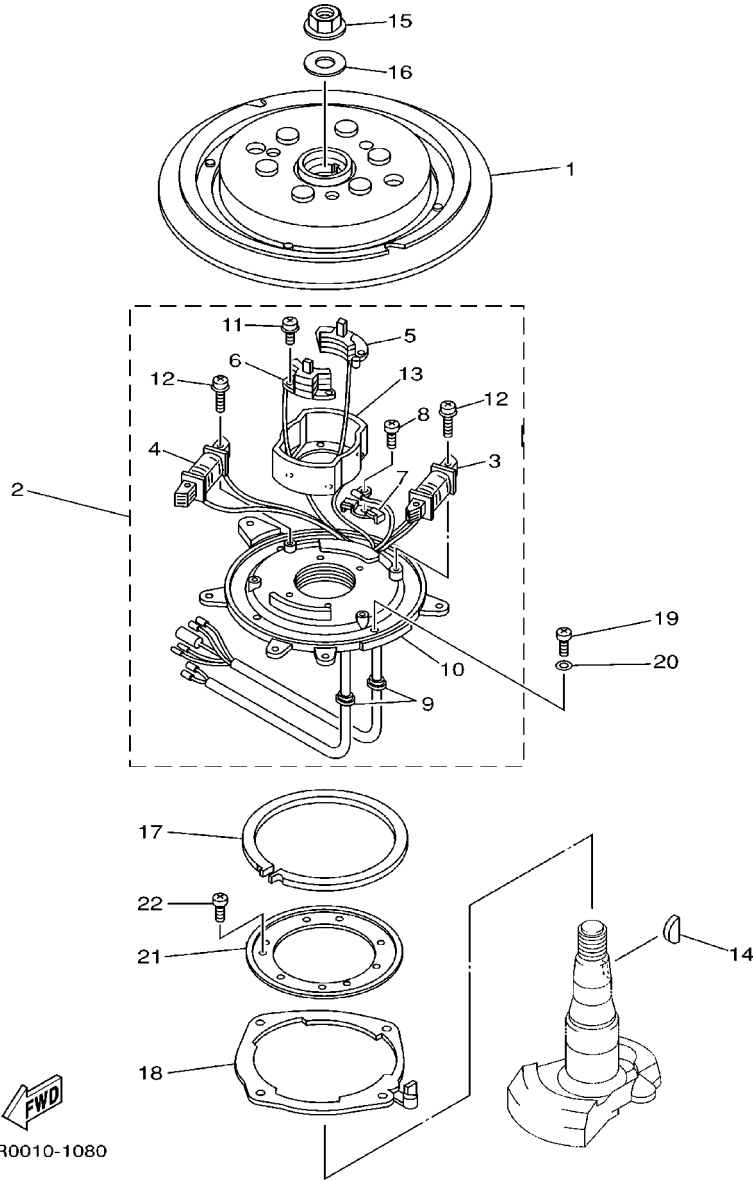



69R0010-1080

REF. NO.	PART NO. CODIGO NO.	DESCRIPTION DESCRIPTION	MH	WH	W	REMARKS OBSERVACION
1	61N-85550-10	ROTOR ASSY ROTOR COMPLETO	1			
	61T-85550-10	ROTOR ASSY ROTOR COMPLETO		1	1	
2	69P-85560-00	BASE ASSY CONJUNTO BASE	1	1	1	
3	69P-85541-09	.COIL, CHARGE .BOBINA DE CARGA	1	1	1	
4	61N-81313-09	.COIL, LIGHTING 1 .BOBINA DE ILUMINACION 1	1	1	1	
5	61N-85543-09	.COIL, PULSER .BOBINA DE PULSACION	1	1	1	
6	61N-85543-19	.COIL, PULSER .BOBINA DE PULSACION	1	1	1	
7	6E9-81328-70	.CLAMP .GRAMPA	1	1	1	
8	97802-04006	.SCREW, PAN HEAD .TORNILLO DE CABEZA CON PLANA	1	1	1	
9	6E9-85516-70	.GROMMET .ESPACIADOR	2	2	2	
10	69P-85561-00	BASE, MAGNETO BASE DE MAGNETO	1	1	1	
11	97607-04112	.SCREW, PAN HEAD WITH WASHER .TORNILLO CAB CON PLANA C/ARAN	4	4	4	
12	97607-06125	.SCREW, PAN HEAD WITH WASHER .TORNILLO CAB CON PLANA C/ARAN	4	4	4	
13	61N-85537-00	.COVER .CUBIERTA	1	1	1	
14	90280-05015	KEY, WOODRUFF CUNA WOODRUFF	1	1	1	
15	90179-16M05	NUT TUERCA	1	1	1	
16	90201-16M44	WASHER, PLATE ARANDELA PLANA	1	1	1	
17	676-41611-00	RETAINER, MAGNETO BASE RETENEDOR BASE MAGNETO	1	1	1	
18	676-41613-00	PLATE, BASE FRICTION PLACA DE BASE DE FRICCION	1	1	1	
19	97880-05012	SCREW, PAN HEAD TORNILLO DE CABEZA CON PLANA	4	4	4	
20	92990-05600	WASHER, PLATE ARANDELA	4	4	4	
21	689-41612-01	RETAINER, MAGNETO BASE RETENEDOR BASE MAGNETO	1	1	1	
22	97880-06010	SCREW, PAN HEAD TORNILLO DE CABEZA CON PLANA	4	4	4	

FIG. 9 ELECTRICAL 1

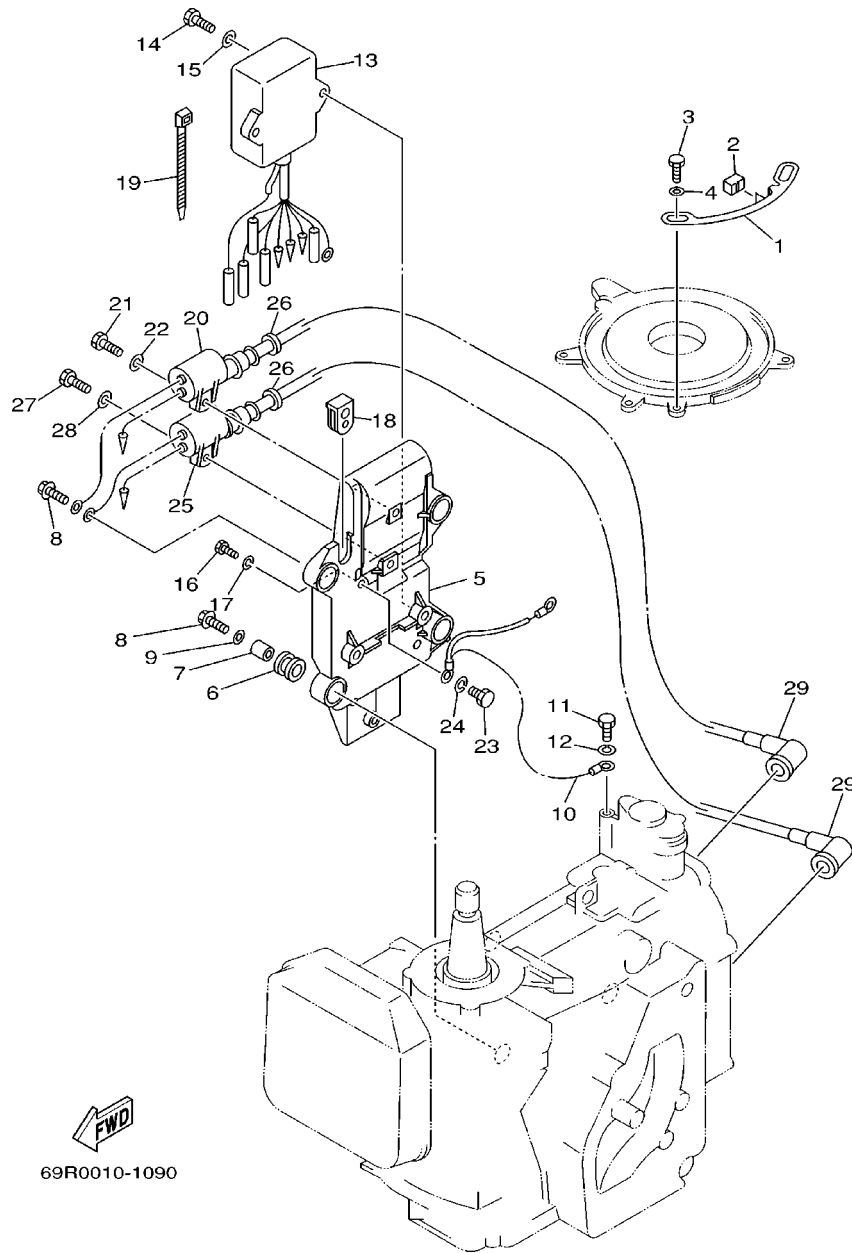
EQUIPO ELECTRICO 1



69R0010-1090

REF. NO.	PART NO. CODIGO NO.	DESCRIPTION DESCRIPTION	MH	WH	W	REMARKS OBSERVACION
1	61N-41615-00	STOPPER, MAGNETO BASE RETENEDOR, BASE MAGNETO	1	1	1	
2	61N-44194-01	CAP	1	1		E25B,25B
	61T-44194-01	CAP	1	1	1	30H
3	97095-06010	BOLT PERNO	2	2	2	
4	92995-06600	WASHER ARANDELA	2	2	2	
5	61N-85542-00-94	BRACKET SOPORTE	1	1	1	
6	61N-82317-00	DAMPER, IGNITION COIL AMORTIGUADOR BOBINA ENCENDIDO	4	4	4	
7	624-42542-00	PIPE TUBO	4	4	4	
8	90119-06M95	BOLT, WITH WASHER TORNILLO CON ARANDELA	4	4	4	
9	90201-06M30	WASHER, PLATE ARANDELA PLANA	2	2	2	
10	61N-82519-01	WIRE, EARTH LEAD CABLE CONDUCTOR A TIERRA	1	1	1	
11	97090-06012	BOLT PERNO	1	1	1	
12	92990-06100	WASHER, SPRING ARANDELA	1	1	1	
13	61N-85540-11	C.D.I. UNIT ASSY UNIDAD C.D.I. COMPLETA	1	1	1	
14	97095-06020	BOLT PERNO	2	2	2	
15	92995-06600	WASHER ARANDELA	2	2	2	
16	97090-06012	BOLT PERNO	1	1	1	
17	92990-06100	WASHER, SPRING ARANDELA	1	1	1	
18	6H3-81922-00	GROMMET TAPON PROTECTOR	1	1	1	
19	90465-13M11	CLAMP BRIDA	1	1	1	
20	61N-85570-00	IGNITION COIL ASSY BOBINA DE IGNICION COMPLETO	1	1	1	
	6H5-85570-00	IGNITION COIL ASSY BOBINA DE IGNICION COMPLETO	1			25B,30H-FOR CARIB
21	97095-06020	BOLT PERNO	1	1	1	
22	92995-06600	WASHER ARANDELA	1	1	1	
23	97090-06012	BOLT PERNO	1	1	1	
24	92990-06100	WASHER, SPRING ARANDELA	1	1	1	
25	61N-85570-10	IGNITION COIL ASSY BOBINA DE IGNICION COMPLETO	1	1	1	

FIG. 9 ELECTRICAL 1

EQUIPO ELECTRICO 1

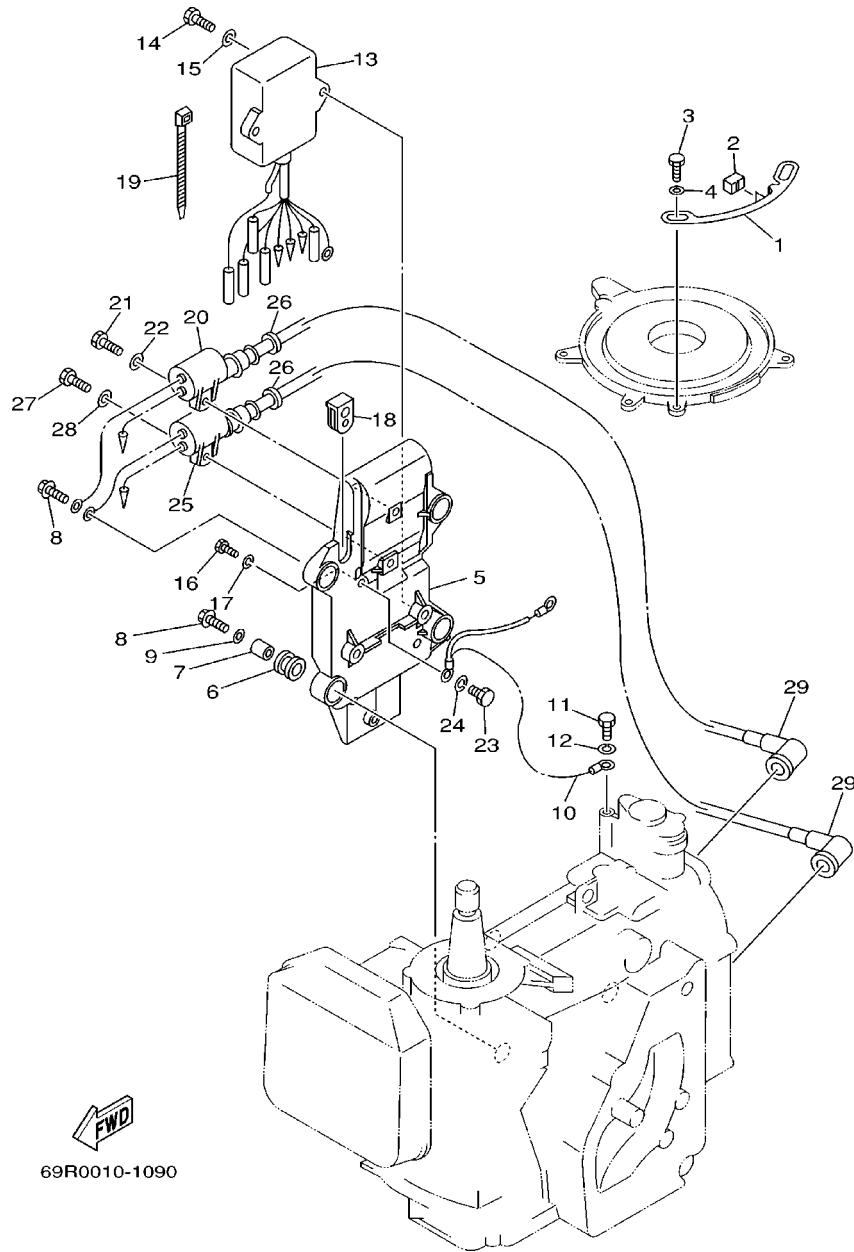

REF. NO.	PART NO. CODIGO NO.	DESCRIPTION DESCRIPTION	MH	WH	W	REMARKS OBSERVACION
25	61N-85570-00	IGNITION COIL ASSY BOBINA DE IGNICION COMPLETO	1			25B,30H-FOR CARIB
26	90480-25161	GROMMET TAPON	2	2	2	
27	97095-06020	BOLT PERNO	1	1	1	
28	92995-06600	WASHER ARANDELA	1	1	1	
29	663-82370-01	PLUG CAP ASSY TAPON DE BUJIA COMPLT	2	2	2	
	6G1-82370-21	PLUG CAP ASSY TAPON DE BUJIA COMPLT	2			FOR CARIB

69R0010-1090

FIG. 10 ELECTRICAL 2

EQUIPO ELECTRICO 2

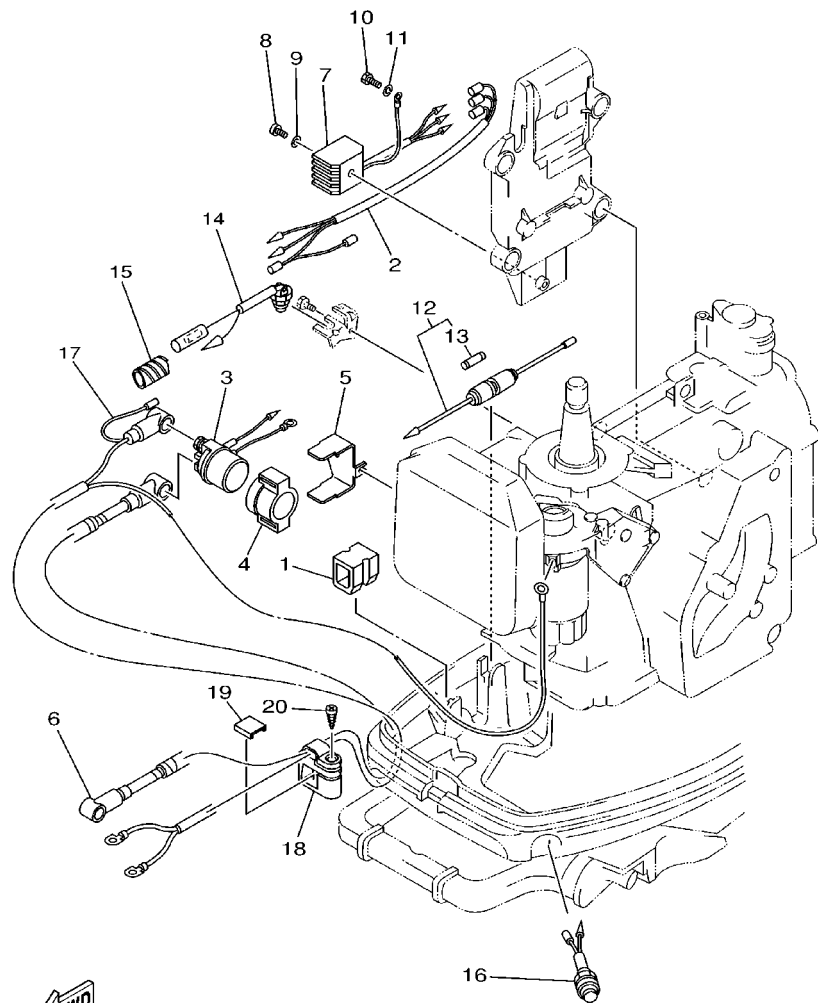

69R0010-1100

REF. NO.	PART NO. CODIGO NO.	DESCRIPTION DESCRIPTION	MH	WH	W	REMARKS OBSERVACION
1	90480-17M08	GROMMET TAPON		3		
2	689-81971-00	WIRE, LEAD CABLE CONDUCTOR		1		
3	6G1-81941-10	STARTER RELAY ASSY RELE DE ARRANQUE		1		
4	6G1-81952-00	HOLDER, RELAY SOSTEN DE RELE		1		
5	61T-81945-01	PLATE, SWITCH FITTING PLACA ACCESORIA DE INTERRUP.		1		
6	689-82531-02	WIRE, LEAD CABLE CONDUCTOR		1		
7	664-81970-61	RECTIFIER ASSY RECTIFICADOR COMPLETO		1		
8	97880-05025	SCREW, PAN HEAD TORNILLO DE CABEZA CON PLANA		1		
9	92990-05600	WASHER, PLATE ARANDELA		1		
10	97090-06012	BOLT PERNO		1		
11	92990-06100	WASHER, SPRING ARANDELA		1		
12	682-82150-10	FUSE HOLDER ASSY PORTA-FUSIBLES COMPLETO		1		
13	682-82151-00	.FUSE (20A) .FUSIBLE (20A)		1		
14	689-82540-01	NEUTRAL SWITCH ASSY INTERRUPTOR NEUTRAL COMPL		1		
15	90446-10M02	HOSE TUBO RESEIRADERO		1		
16	689-81870-00	STARTING SWITCH ASSY INTERRUPTOR DE ARRANQUE COMPL.		1		
17	689-82105-13	WIRE HARNESS ARNES DE CABLES		1		
18	689-82594-00	CLAMP GRAMPA		1		
19	682-42525-00	PLATE, FRICTION PLACA DE FRICCION		1		
20	90161-06M00	SCREW, TAPPING TORNILLO DE CABEZA PLANA		1		

FIG. 11 ELECTRICAL 3

EQUIPO ELECTRICO 3

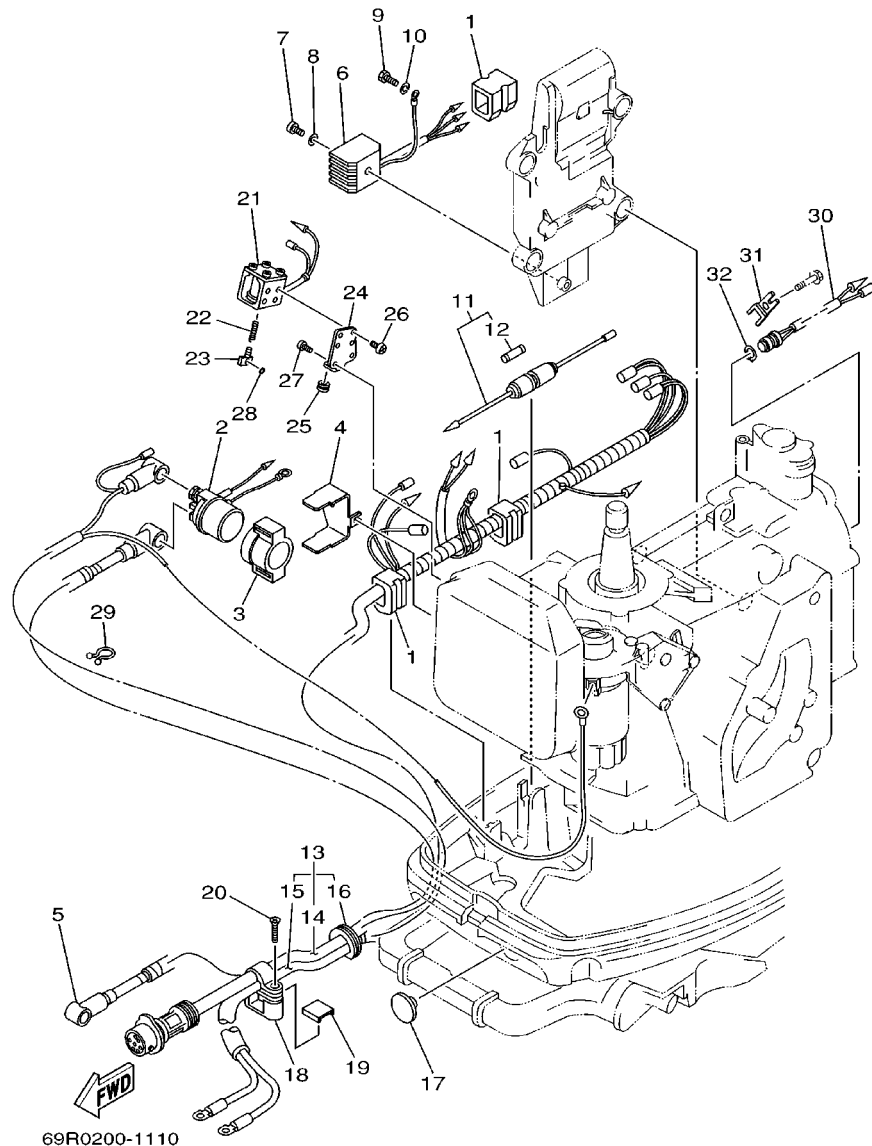

REF. NO.	PART NO. CODIGO NO.	DESCRIPTION DESCRIPTION	MH	WH	W	REMARKS OBSERVACION
1	90480-17M08	GROMMET TAPON			3	
2	6G1-81941-10	STARTER RELAY ASSY RELE DE ARRANQUE			1	
3	6G1-81952-00	HOLDER, RELAY SOSTEN DE RELE			1	
4	61T-81945-01	PLATE, SWITCH FITTING PLACA ACCESORIA DE INTERRUPT.			1	
5	689-82531-02	WIRE, LEAD CABLE CONDUCTOR			1	
6	664-81970-61	RECTIFIER ASSY RECTIFICADOR COMPLETO			1	
7	97880-05025	SCREW, PAN HEAD TORNILLO DE CABEZA CON PLANA			1	
8	92990-05600	WASHER, PLATE ARANDELA			1	
9	97090-06012	BOLT PERNO			1	
10	92990-06100	WASHER, SPRING ARANDELA			1	
11	682-82150-10	FUSE HOLDER ASSY PORTA-FUSIBLES COMPLETO			1	
12	682-82151-00	.FUSE (20A) .FUSIBLE (20A)			1	
13	61T-82580-00	WIRE HARNESS ASSY 2 CONJUNTO DE CABLES 2			1	
14	61T-82590-00	.WIRE HARNESS ASSY .CONJUNTO DE CABLES			1	
15	689-82105-13	.WIRE HARNESS .ARNES DE CABLES			1	
16	689-42724-50	GROMMET .TAPON			1	
17	90480-17165	GROMMET TAPON			1	
18	689-82594-10	CLAMP GRAMPA			1	
19	682-42525-00	PLATE, FRICTION PLACA DE FRICCION			1	
20	90161-06M00	SCREW, TAPPING TORNILLO DE CABEZA PLANA			1	
21	61T-86111-00	COIL, SOLENOID CONJUNTO BOBINA SOLENOIDE			1	EXCEPT FOR TURKEY
22	682-86116-00	WIRE, PULL ALAMBRE-JALADOR			1	EXCEPT FOR TURKEY
23	682-86117-00	HOOK, WIRE PULL GANCHO JALADOR DE ALAMBRE			1	EXCEPT FOR TURKEY
24	61T-86112-00	STAY, SOLENOID SOPORTE SOLENOIDE			1	EXCEPT FOR TURKEY
25	90480-10155	GROMMET TAPON			1	EXCEPT FOR TURKEY
26	98503-04006	SCREW, PAN HEAD TORNILLO DE CABEZA CON PLANA			4	EXCEPT FOR TURKEY
27	97880-05012	SCREW, PAN HEAD TORNILLO DE CABEZA CON PLANA			2	EXCEPT FOR TURKEY

FIG. 11 ELECTRICAL 3

EQUIPO ELECTRICO 3

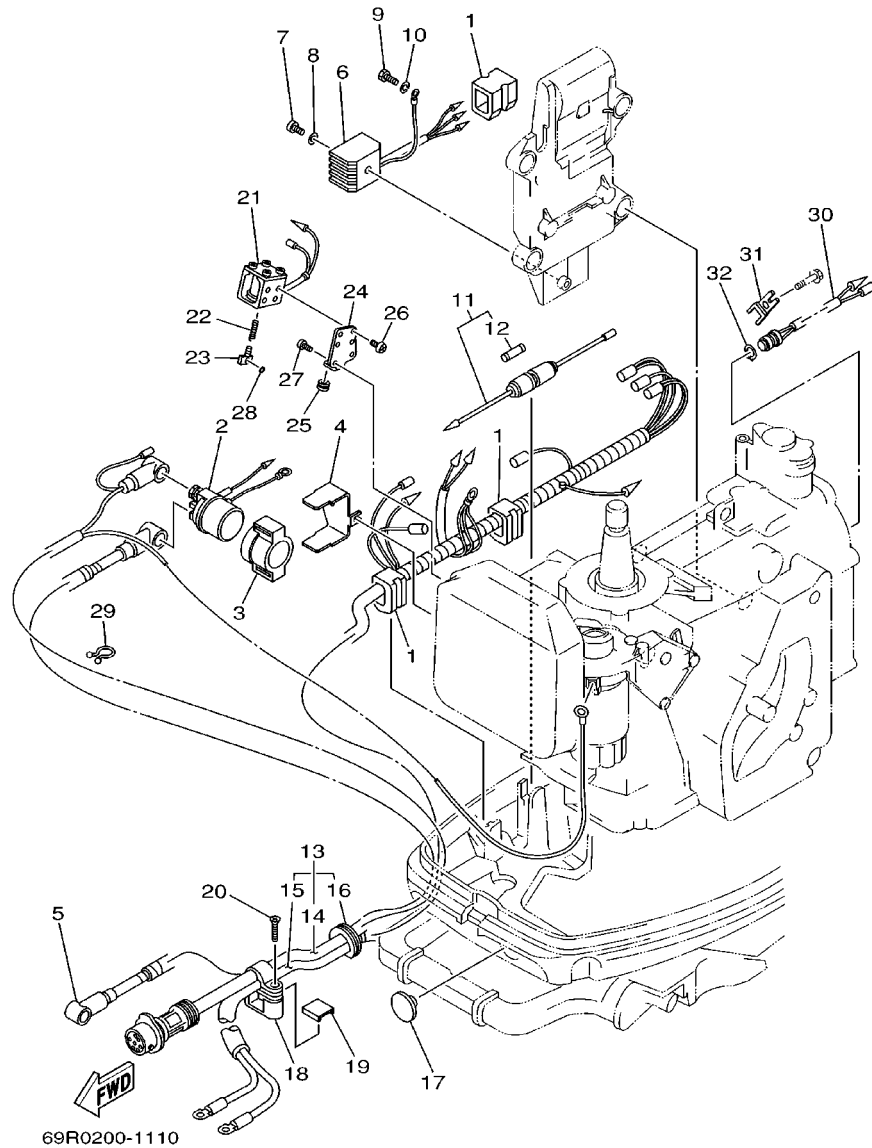

REF. NO.	PART NO. CODIGO NO.	DESCRIPTION DESCRIPTION	MH	WH	W	REMARKS OBSERVACION
28	93210-03261	O-RING ANILLO O			1	EXCEPT FOR TURKEY
29	90465-18147	CLAMP BRIDA			1	EXCEPT FOR TURKEY
30	61T-82560-00	THERMO SWITCH ASSY INTER. DE TERMO			1	
31	61T-82588-00	PLATE PLACA			1	
32	99009-17500	CIRCLIP PRESILLA REDONDA			1	

FIG. 12 STARTING MOTOR

MOTOR DE ARRANQUE

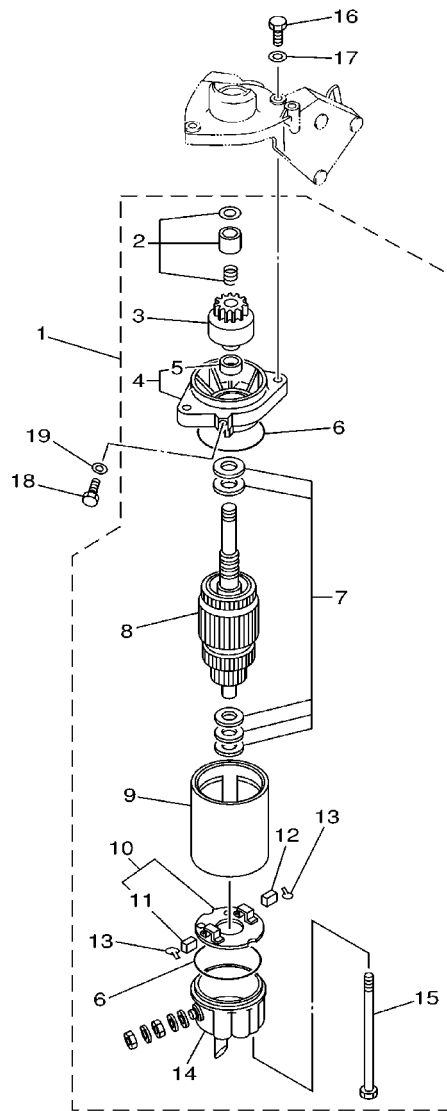

61R0010-4110

REF. NO.	PART NO. CODIGO NO.	DESCRIPTION DESCRIPTION	MH	WH	W	REMARKS OBSERVACION
1	689-81800-13	STARTING MOTOR ASSY MOTOR DE ARRANQUE COMPLETO		1	1	
2	689-81857-11	.PINION STOPPER SET .JUEGO TAPON PINON		1	1	
3	689-81807-12	.GEAR ASSY, STARTING MOTOR .PINON CONJUNTO		1	1	
4	689-81830-11	.FRONT BRACKET ASSY .SOPORTE DELANTERO COMPLETO		1	1	
5	689-81831-00	..METAL, FRONT ..METAL, DELANTERO		1	1	
6	689-81847-11	.O-RING .ANILLO GOMA		2	2	
7	689-81809-11	.WASHER KIT .JUEGO DE ARANDELA		1	1	
8	689-81850-12	.ARMATURE ASSY .INDUCIDO COMPLETO		1	1	
9	689-81810-11	.STATOR ASSY .ESTATOR COMPLETO		1	1	
10	689-81840-11	.BRUSH HOLDER ASSY .SOSTEN DE ESCOBILLA COMPLETO		1	1	
11	689-81812-11	..BRUSH 2 ..ESCOBILLA 2		1	1	
12	689-81811-11	.BRUSH 1 .ESCOBILLA 1		1	1	
13	689-81813-10	.SPRING, BRUSH .RESORTE DE ESCOBILLA		2	2	
14	689-81820-11	.REAR BRACKET ASSY .CUBIERTA TRASERA COMPL		1	1	
15	689-81826-10	BOLT PERNO		2	2	
16	97013-08030	BOLT PERNO		2	2	
17	92903-08600	WASHER, PLATE ARANDELA		2	2	
18	97013-08012	BOLT PERNO		1	1	
19	92903-08600	WASHER, PLATE ARANDELA		1	1	

FIG. 13 BOTTOM COWLING

CUBIERTA INFERIOR

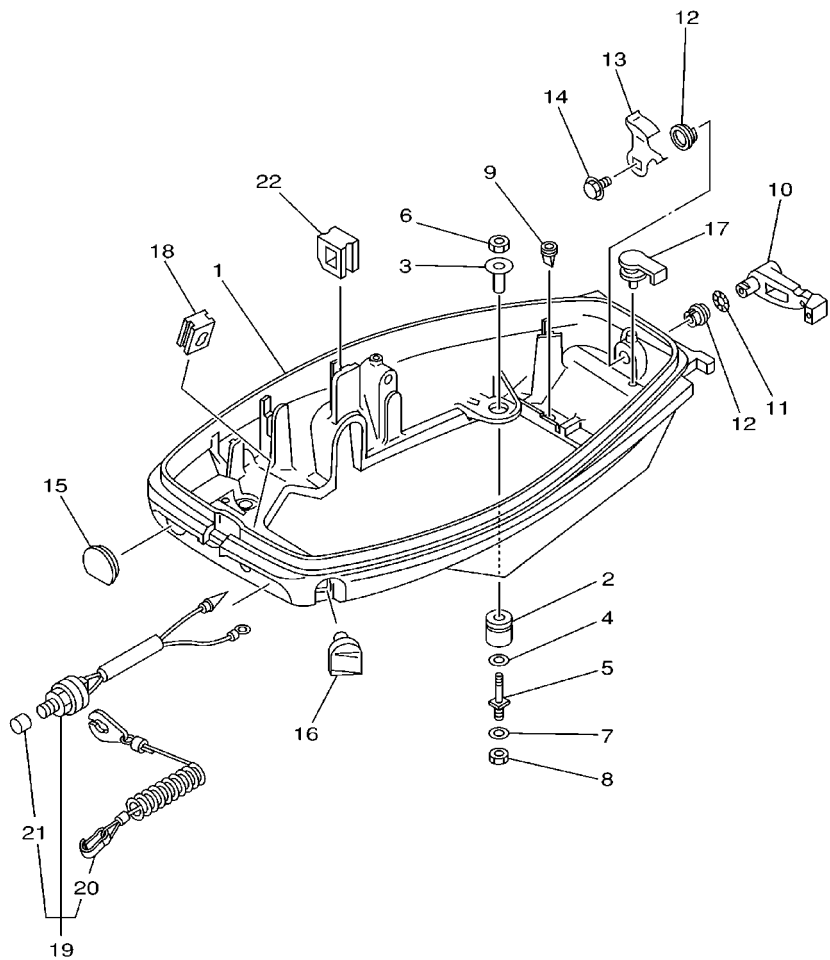

69R0010-1120

REF. NO.	PART NO. CODIGO NO.	DESCRIPTION DESCRIPTION	MH	WH	W	REMARKS OBSERVACION
1	69P-42711-00-4D	COWLING, BOTTOM CUBIERTA INFERIOR	1	1	1	
2	90480-15M06	GROMMET TAPON	4	4	4	
3	90387-08M25	COLLAR COLLAR	4	4	4	
4	90201-08M87	WASHER, PLATE ARANDELA PLANA	4	4	4	
5	6G0-42796-00	BOLT 1 TORNILLO	4	4	4	
6	95380-08700	NUT TUERCA	4	4	4	
7	92995-08600	WASHER ARANDELA	4	4	4	
8	95380-08700	NUT TUERCA	4	4	4	
9	65W-42717-00	RUBBER, SEAL 2 GOMA	2	2	2	
10	689-42815-00	LEVER, CLAMP PALANCA ABRAZADERA	1	1	1	
11	90206-12052	WASHER, WAVE ARANDELA ONDULADA	1	1	1	
12	90386-12069	BUSH BUJE	2	2	2	
13	689-42816-00	LEVER, CLAMP PALANCA ABRAZADERA	1	1	1	
14	90119-06M73	BOLT, WITH WASHER TORNILLO CON ARANDELA	1	1	1	
15	682-42724-00	GROMMET TAPON	1			
	61T-42724-40	GROMMET TAPON		1		
16	689-42725-01	GROMMET TAPON	1		1	
17	647-42523-00	SPACER, FRICTION ESPACIADOR DE FRICCION	1	1	1	
18	61N-26326-00	GROMMET TAPON PROTECTOR	1	1		
	676-42724-40	GROMMET TAPON			1	
19	6E9-82575-02	ENGINE STOP SWITCH ASSY INTERRUPTOR DE PARADA COMPL	1	1		
20	682-82556-00	.STOPPER .RETEN	1	1		
21	689-8257Y-00	.CAP .CASQUILLO	1	1		
22	90480-17M08	GROMMET TAPON	1			

FIG. 14 STEERING

DIRECCION

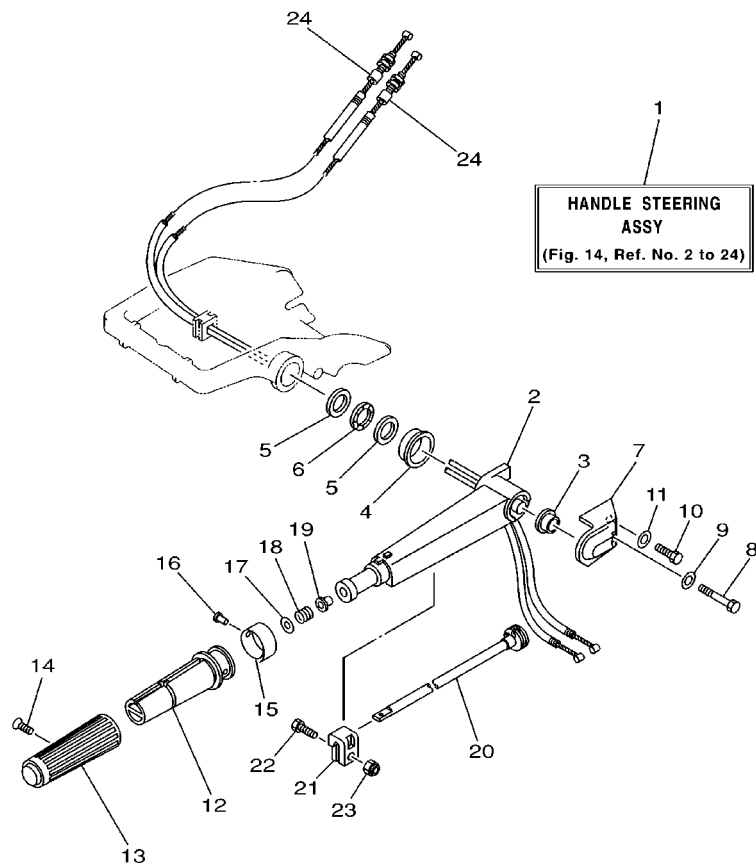

REF. NO.	PART NO. CODIGO NO.	DESCRIPTION DESCRIPTION	MH	WH	W	REMARKS OBSERVACION
1	69P-W0084-00-4D	HANDLE STEERING ASSY CONJUNTO DE MANIJA	1	1		
2	689-42111-01-4D	HANDLE, STEERING MANIJA DE DIRECCION	1	1		
3	90387-13003	COLLAR COLLAR	1	1		
4	90387-33001	COLLAR COLLAR	1	1		
5	90201-28013	WASHER, PLATE ARANDELA PLANA	2	2		
6	90206-28001	WASHER, WAVE ARANDELA ONDULADA	1	1		
7	69P-42112-00-4D	HANDLE, STEERING MANIJA DE DIRRECCION	1	1		
8	97095-06050	BOLT PERNO	1	1		
9	92995-06600	WASHER ARANDELA	1	1		
10	97095-06020	BOLT PERNO	1	1		
11	92995-06600	WASHER ARANDELA	1	1		
12	664-42119-00	GRIP, STEERING HANDLE MANGO, MANIJA DE DIRRECCION	1	1		
13	6F6-42177-A0	RUBBER, HANDLE HULE DE MANIJA	1	1		
14	90149-05M13	SCREW TORNILLO DE REGLAJE	1	1		
15	6G1-42137-10	INDICATOR, THROTTLE INDICADOR ACELERADOR	1	1		
16	90269-02M09	RIVET REMACHE	1	1		
17	92903-10600	WASHER, PLATE ARANDELA	1	1		
18	90501-23215	SPRING, COMPRESSION RESORTE DE COMPRESION	1	1		
19	90386-08032	BUSH BUJE	1	1		
20	689-42138-00	LEVER, THROTTLE PLANCA DE ACELERACION	1	1		
21	656-42126-01	FRICTION, STEERING HANDLE GRIP FRICCION DE MANGO DIRECCION	1	1		
22	97095-06020	BOLT PERNO	1	1		
23	90185-06062	NUT, SELF-LOCKING TUERCA AUTOBLOCANTE	1	1		
24	61N-26311-00	CABLE, THROTTLE 1 CABLE DE ACELERADOR 1	2	2		



69R0200-1140

FIG. 15 CONTROL 1

CONTROL 1

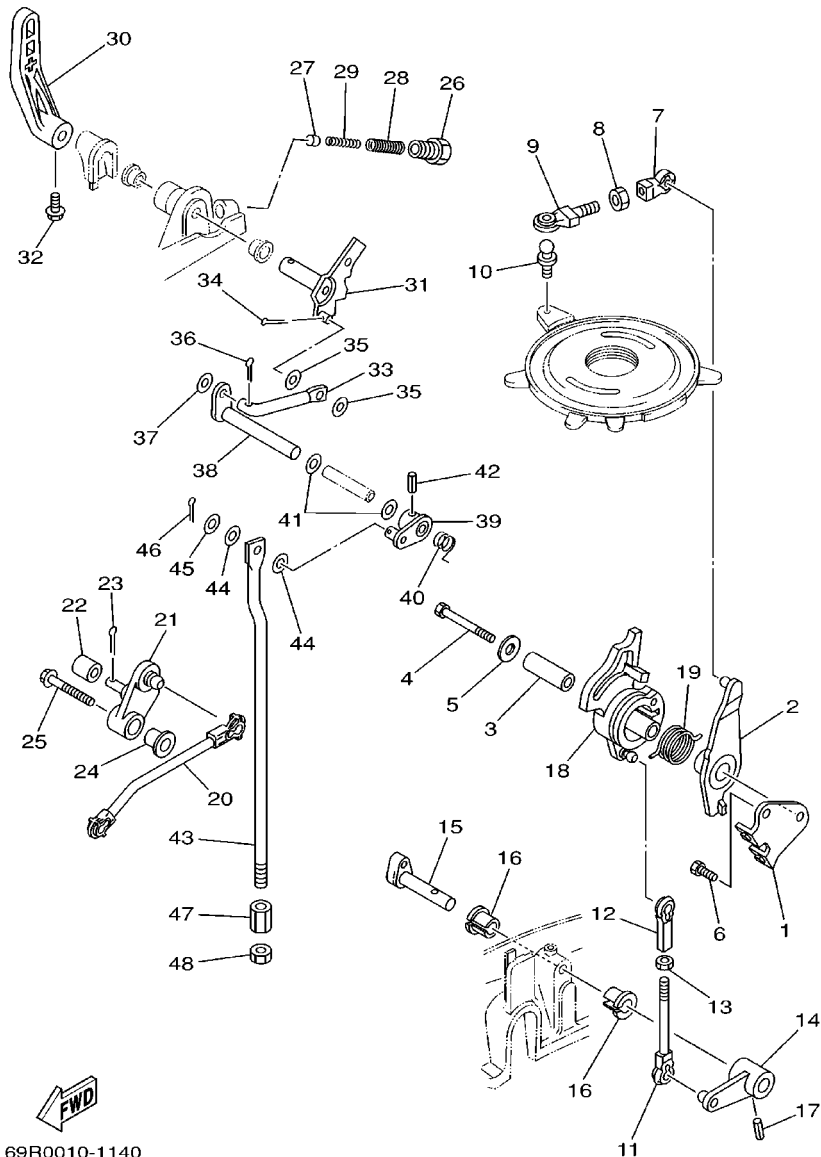

69R0010-1140

REF. NO.	PART NO. CODIGO NO.	DESCRIPTION DESCRIPTION	MH	WH	W	REMARKS OBSERVACION
1	69P-14497-00	STAY, THROTTLE WIRE SOPORTE VALVULA DE OBTURACION	1	1	1	
2	69P-41631-00	LEVER, MAGNETO CONTROL PALANCA DE CONTROL DE MAGNETO	1	1	1	
3	90387-06M59	COLLAR COLLAR	1	1	1	
4	97095-06045	BOLT PERNO	1	1	1	
5	90201-06416	WASHER, PLATE ARANDELA PLANA	1	1	1	
6	97095-06012	BOLT PERNO	1	1	1	
7	662-41237-01	JOINT, LINK CONECTOR	1	1	1	
8	95380-05700	NUT TUERCA	1	1	1	
9	679-41241-01	ROD, LINK VARILLA	1	1	1	
10	663-85518-00	JOINT, BALL CONECTOR	1	1	1	
11	682-41238-01	JOINT, LINK CONECTOR	1	1	1	
12	682-41237-00	JOINT, LINK CONECTOR	1	1	1	
13	95380-05600	NUT TUERCA	1	1	1	
14	69P-42157-00-94	LEVER, THROTTLE PALANCA DE ACELERADOR	1	1	1	
15	656-42153-00-94	SHAFT, THROTTLE CONTROL EJE CONTROL DEL ACELERADOR	1	1	1	
16	90386-10009	BUSH BUJE	2	2	2	
17	91690-40018	PIN, SPRING PASADOR DE RESORTE	1	1	1	
18	69P-41213-00	CAM, ACCEL. LEVA ACELERADOR	1	1	1	
19	69P-42167-00	SPRING 1 RESORTE 1	1	1	1	
20	69P-41241-00	ROD, LINK VARILLA	1	1	1	
21	69P-42154-00	LEVER, THROTTLE CONTROL PALANCA CONTROL ACELERADOR	1	1	1	
22	62Y-42171-00	BUSHING BUJE	1	1	1	
23	91490-16010	PIN, COTTER PASADOR DE CHAVETA	1	1	1	
24	90387-06M60	COLLAR COLLAR	1	1	1	
25	90119-06M17	BOLT, WITH WASHER TORNILLO CON ARANDELA	1	1	1	
26	664-42715-00	BUSHING BUJE	1	1	1	
27	664-44167-00	PLUNGER, SHIFT CAM EMBOLO DE CAMBIO	1	1	1	

FIG. 15 CONTROL 1

CONTROL 1

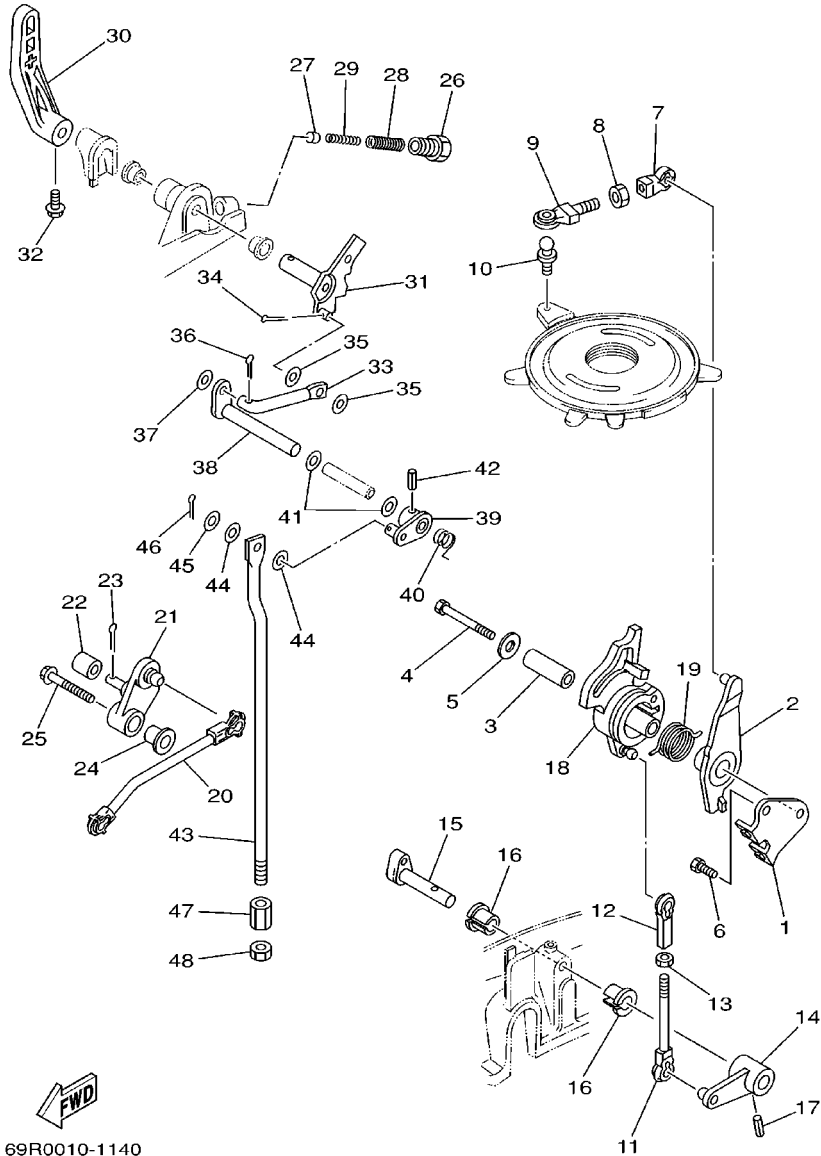

69R0010-1140

REF. NO.	PART NO. CODIGO NO.	DESCRIPTION DESCRIPTION	MH	WH	W	REMARKS OBSERVACION
28	90501-14M07	SPRING, COMPRESSION RESORTE DE COMPRESION	1	1	1	
29	90501-09M08	SPRING, COMPRESSION RESORTE DE COMPRESION	1	1	1	
30	689-44111-01-4D	HANDLE, GEAR SHIFT MANIJA DE CAMBIO DE MARCHAS	1	1	1	
31	664-44113-01	CAM PLATE, HANDLE PLACA DE LA LEVA DEL MANGO	1	1	1	
32	90105-06M07	BOLT, WASHER BASED TORNILLO CON ARANDELA	1	1	1	
33	664-44142-00	JOINT CONECTOR	1	1	1	
34	91490-16010	PIN, COTTER PASADOR DE CHAVETA	1	1	1	
35	90202-06007	WASHER, PLATE ARANDELA DE PLANA	2	2	2	
36	91490-12010	PIN, COTTER PASADOR DE CHAVETA	1	1	1	
37	92990-05600	WASHER, PLATE ARANDELA	1	1	1	
38	689-44121-01	LEVER, SHIFT ROD PALANCA VARILLA CAMBIOS	1	1	1	
39	689-44125-00	LEVER, SHIFT ROD PALANCA VARILLA CAMBIOS	1	1	1	
40	90508-14M13	SPRING, TORSION RESORTE DE TORSION	1	1	1	
41	90202-10024	WASHER, PLATE ARANDELA DE PLANA	2	2	2	
42	91690-40016	PIN, SPRING PASADOR DE RESORTE	1	1	1	
43	61N-44143-00	ROD, SHIFT VARILLA DE CAMBIO	1	1	1	
44	90202-06007	WASHER, PLATE ARANDELA DE PLANA	2	2	2	
45	92990-05600	WASHER, PLATE ARANDELA	1	1	1	
46	91490-20010	PIN, COTTER PASADOR DE CHAVETA	1	1	1	
47	61N-44146-00	CONNECTOR, SHIFT ROD CONECTOR VARILLA DE CAMBIO	1	1	1	
48	95380-06600	NUT, HEXAGON TUERCA	1	1	1	

FIG. 16 CONTROL 2

CONTROL 2

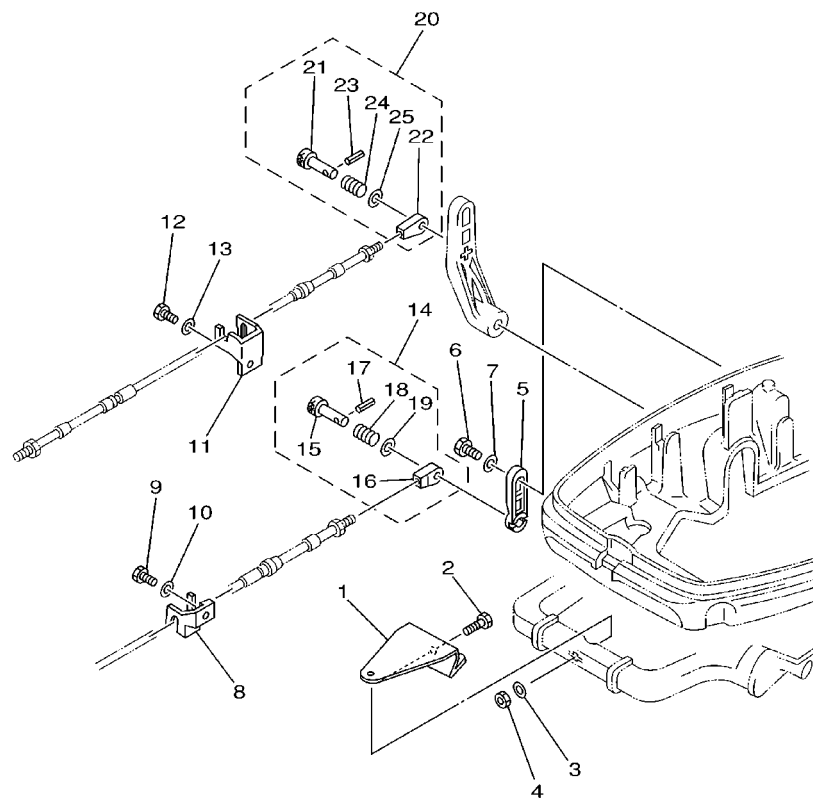

REF. NO.	PART NO. CODIGO NO.	DESCRIPTION DESCRIPTION	MH	WH	W	REMARKS OBSERVACION
1	689-48511-01	HOOK, STEERING GANCHO DIRECCION			1	
2	97075-10040	BOLT PERNO			1	
3	92990-10600	WASHER, PLATE ARANDELA			1	
4	90185-10051	NUT, SELF-LOCKING TUERCA AUTOBLOCANTE			1	
5	648-48534-50-4D	THROTTLE LEVER, CONTROL PALANCA DE CONTROL DE ACELERAC			1	
6	97095-06012	BOLT PERNO			1	
7	92995-06600	WASHER ARANDELA			1	
8	689-48532-50	BRACKET, REMOTE CONTROL 2 SOPORTE DE CONTROL REMOTO			1	
9	97095-06016	BOLT PERNO			1	
10	92995-06600	WASHER ARANDELA			1	
11	689-48531-50	BRACKET, REMOTE CONTROL 1 SOPORTE DE CONTROL REMOTO			1	
12	97095-06016	BOLT PERNO			1	
13	92995-06600	WASHER ARANDELA			1	
14	648-48340-50	CABLE END ASSY TERMINAL DE CABLE COMPL.			1	
15	617-48361-91	HOOK, CABLE GANCHO CABLE			1	
16	617-48346-90	CABLE END, REMOTE CONTROL TERMINAL CABLE DE CONTROL REM			1	
17	91690-30012	PIN, SPRING PASADOR DE RESORTE			1	
18	90501-10264	SPRING, COMPRESSION RESORTE DE COMPRESION			1	
19	92990-08600	WASHER, PLATE ARANDELA			1	
20	648-48330-50	CABLE END ASSY TERMINAL DE CABLE COMPL.			1	
21	617-48331-91	HOOK, CABLE GANCHO CABLE			1	
22	648-48346-50	CABLE END, REMOTE CONTROL TERMINAL CABLE DE CONTROL REM			1	
23	91690-30012	PIN, SPRING PASADOR DE RESORTE			1	
24	90501-10071	SPRING, COMPRESSION RESORTE DE COMPRESION			1	
25	92990-08600	WASHER, PLATE ARANDELA			1	



69R0200-1160

FIG. 17 BRACKET 1

SOPORTE 1

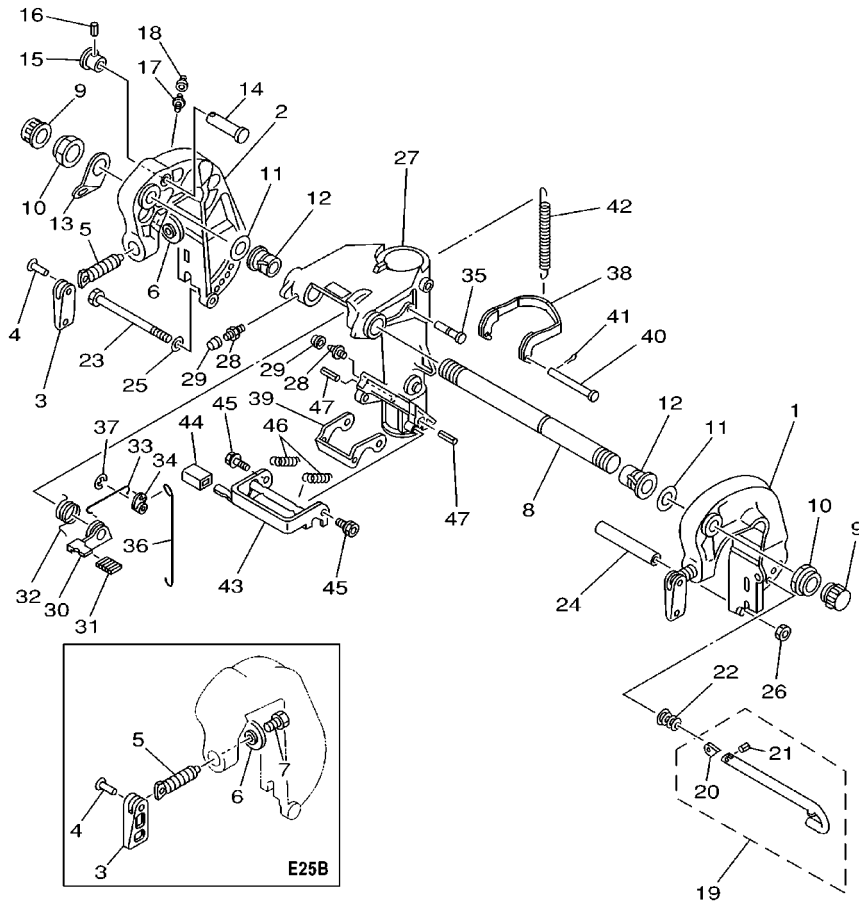

69R0200-1170

REF. NO.	PART NO. CODIGO NO.	DESCRIPTION DESCRIPTION	MH	WH	W	REMARKS OBSERVACION
1	689-43111-03-4D	BRACKET, CLAMP SOPORTE DE LA ABRAZADERA	1	1	1	
2	689-43112-02-4D	BRACKET, CLAMP SOPORTE DE LA ABRAZADERA	1	1	1	
3	6E0-43118-01	HANDLE, TRANSOM CLAMP MANIJA DE LA ABRAZADERA DEL ES	2	2	2	25B,30H
	663-43118-01	HANDLE, TRANSOM CLAMP MANIJA DE LA ABRAZADERA DEL ES	2			E25B
4	90243-04M01	PIN PASADOR	2	2	2	25B,30H
	90243-04007	PIN PASADOR	2			E25B
5	90149-14030	SCREW TORNILLO DE REGLAJE	2	2	2	25B,30H
	6G0-43116-00	SCREW, TRANSOM CLAMP TORNILLO DE ABRAZADERA	2			E25B
6	648-43114-01	PAD, TRANSOM CLAMP ARANDELA DE ABRAZADERA	2	2	2	25B,30H
	6F5-43114-00	PAD, TRANSOM CLAMP ARANDELA DE ABRAZADERA	2			E25B
7	90109-06M12	BOLT PERNO	2			E25B
8	6J8-43131-01	BOLT, CLAMP BRACKET TORNILLO DE ABRAZADERA DEL SOP	1	1	1	
9	6G5-43145-01	CAP, CLAMP BRACKET TAPA	2	2	2	
10	90185-22043	NUT, SELF-LOCKING TUERCA AUTOBLOCANTE	2	2	2	
11	90201-22M03	WASHER, PLATE ARANDELA PLANA	2	2	2	
12	90386-22M67	BUSH BUJE	2	2	2	
13	6J8-43113-01	PLATE, CLAMP BRACKET PLACA ABRAZADERA SOPORTE	1	1	1	
14	689-43191-00	SHAFT, STOPPER EJE DE TOPE	1	1	1	
15	689-43192-01	KNOB, STOPPER PERILLA DE TOPE	1	1	1	
16	91690-30016	PIN, SPRING PASADOR DE RESORTE	1	1	1	
17	93700-06M03	NIPPLE, GREASE NIPLE DE ENGRASAR	1	1	1	
18	663-45119-00	CAP, GREASE NIPPLE TAPA DE GRASERA	1	1	1	AP
19	689-43160-00	TILT ROD ASSY VARILLA DE BASCULACION COMPL.	1	1	1	
20	689-43165-00	.PLATE, TILT LOCK .PLACA DE TOPE, VARILLA SEGUR	1	1	1	
21	91690-30008	.PIN, SPRING .PASADOR DE RESORTE	1	1	1	
22	90502-10M07	SPRING, CONICAL RESORTE CONICO	1	1	1	
23	90101-08339	BOLT TORNILLO	1	1	1	

FIG. 17 BRACKET 1

SOPORTE 1

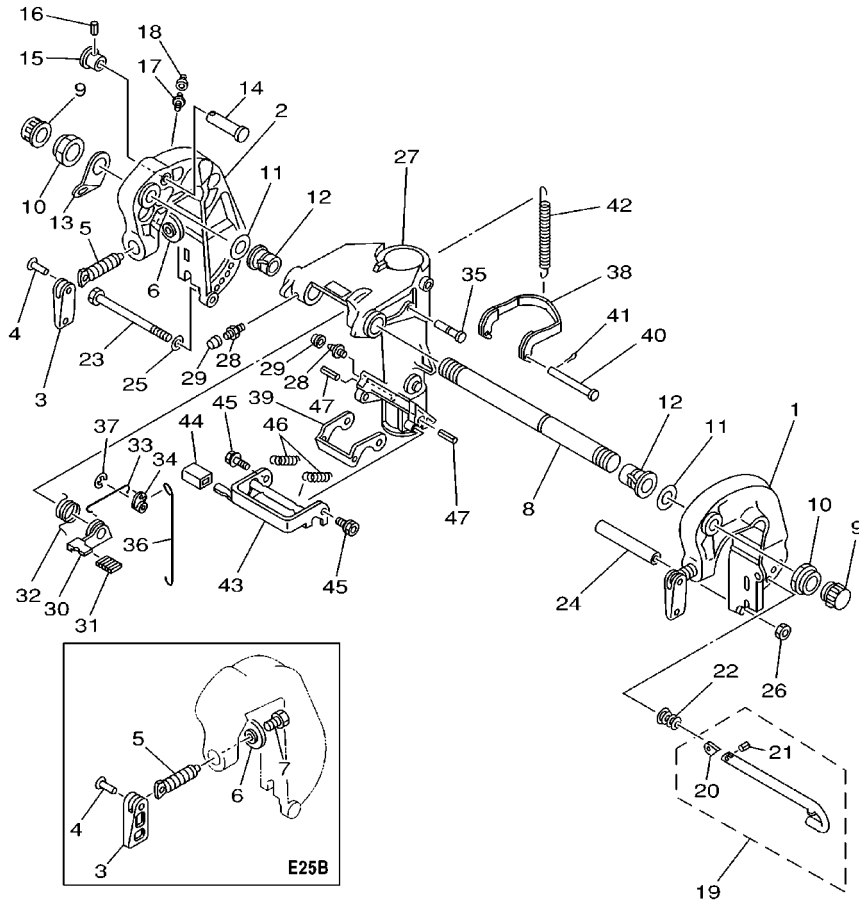

69R0200-1170

REF. NO.	PART NO. CODIGO NO.	DESCRIPTION DESCRIPTION	MH	WH	W	REMARKS OBSERVACION
24	90387-08M03	COLLAR COLLAR	1	1	1	
25	92995-08600	WASHER ARANDELA	1	1	1	
26	95380-08600	NUT TUERCA	1	1	1	
27	689-43311-03-4D	BRACKET, SWIVEL 1 SOPORTE GIRATORIO 1	1	1	1	
28	93700-06M03	NIPPLE, GREASE NIPLE DE ENGRASAR	3	3	3	
29	663-45119-00	CAP, GREASE NIPPLE TAPA DE GRASERA	3	3	3	AP
30	689-43631-00	LEVER, TILT PALANCA DE INCLINACION	1	1	1	
31	689-43633-00	COVER, TILT LEVER CUBIERTA PALANCA DE INCLINACI	1	1	1	
32	689-43643-00	SPRING RESORTE	1	1	1	
33	689-43616-00	ROD, TILT LOCK VARILLA SEGURO DE INCLINACION	1	1	1	
34	648-43642-00	LEVER, TILT 1 PALANCA DE INCLINACION1	1	1	1	
35	90249-06M22	PIN PASADOR	1	1	1	
36	648-43617-00	ROD, TILT LOCK VARILLA SEGURO DE INCLINACION	1	1	1	
37	99080-05600	CIRCLIP PRESILLA REDONDA	1	1	1	
38	689-43614-01	PLATE, TILT LOCK PLACA DE SEGURO DE INCLINACION	1	1	1	
39	648-43615-00	PLATE, TILT LOCK PLACA DE SEGURO DE INCLINACION	1	1	1	
40	90240-05047	PIN, CLEVIS PASADOR CON HOYO	1	1	1	
41	91490-16010	PIN, COTTER PASADOR DE CHAVETA	1	1	1	
42	90506-30M27	SPRING, TENSION RESORTE DE TENSION	1	1	1	
43	689-43681-01	LEVER, SHALLOW WATER DRIVE 1 PALANCA 1	1	1	1	EXCEPT 30H-FOR BRAZIL
44	682-43318-01	COVER CUBIERTA	1	1	1	EXCEPT 30H-FOR BRAZIL
45	90109-06M18	BOLT PERNO	2	2	2	EXCEPT 30H-FOR BRAZIL
46	90506-16M17	SPRING, TENSION RESORTE DE TENSION	2	2	2	EXCEPT 30H-FOR BRAZIL
47	91690-40035	PIN, SPRING PASADOR DE RESORTE	2	2	2	EXCEPT 30H-FOR BRAZIL

FIG. 18 BRACKET 2

SOPORTE 2

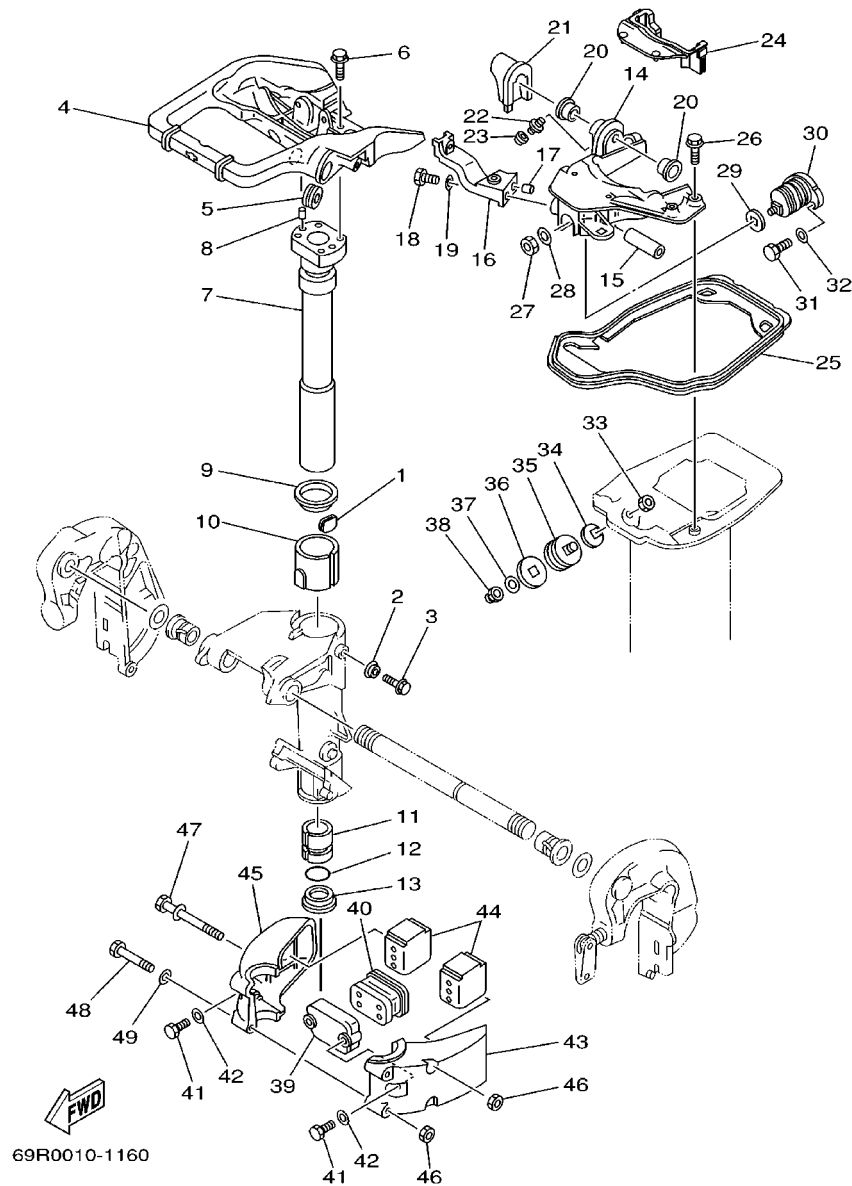

69R0010-1160

REF. NO.	PART NO. CODIGO NO.	DESCRIPTION DESCRIPTION	MH	WH	W	REMARKS OBSERVACION
1	648-42528-00	PLATE, FRICTION PIEZA DE FRICCION	1	1	1	
2	689-43373-01	SEAL, DAMPER SELLO DE GOMA	1	1	1	
3	90105-06M18	BOLT, WASHER BASED TORNILLO CON ARANDELA	1	1	1	
4	69P-42511-00-4D	BRACKET, STEERING SOPORTE DE DIRECCION	1	1	1	
5	90480-29045	GROMMET TAPON	1	1		
6	90105-06M07	BOLT, WASHER BASED TORNILLO CON ARANDELA	4	4	4	
7	689-42521-00-94	SHAFT, STEERING PIVOT EJE PIVOTE DE DIRECCION	1	1	1	
8	93608-12063	PIN, DOWEL PASADOR DE CLAVIJA	2	2	2	
9	90209-47016	WASHER ARANDELA DE SEPARACION	1	1	1	
10	90386-47M22	BUSH BUJE	1	1	1	
11	90386-38090	BUSH BUJE	1	1	1	
12	93210-37160	O-RING ANILLO O	1	1	1	
13	90386-38022	BUSH BUJE	1	1	1	
14	69P-44518-00-94	BRACKET COMP. SOPORTE	1	1	1	
15	90387-10M39	COLLAR COLLAR	1	1	1	
16	648-44519-00-94	BRACKET SOPORTE	1	1	1	
17	93606-12019	PIN, DOWEL PASADOR DE CLAVIJA	1	1	1	
18	97095-06018	BOLT PERNO	1	1	1	
19	92995-06600	WASHER ARANDELA	1	1	1	
20	90381-12M01	BUSH, SOLID BUJE SOLIDO	2	2	2	
21	689-42718-00	RUBBER, SEAL 3 GOMA	1	1	1	
22	93700-06M03	NIPPLE, GREASE NIPLE DE ENGRASAR	1	1	1	
23	663-45119-00	CAP, GREASE NIPPLE TAPA DE GRASERA	1	1	1	AP
24	69P-42717-00	RUBBER, SEAL 2 GOMA	1	1	1	
25	69P-42716-00	RUBBER, SEAL 1 SELLO DE GOMA 1	1	1	1	
26	90105-06M08	BOLT, WASHER BASED TORNILLO CON ARANDELA	4	4	4	
27	90170-10M42	NUT TUERCA	1	1	1	

FIG. 18 BRACKET 2

SOPORTE 2

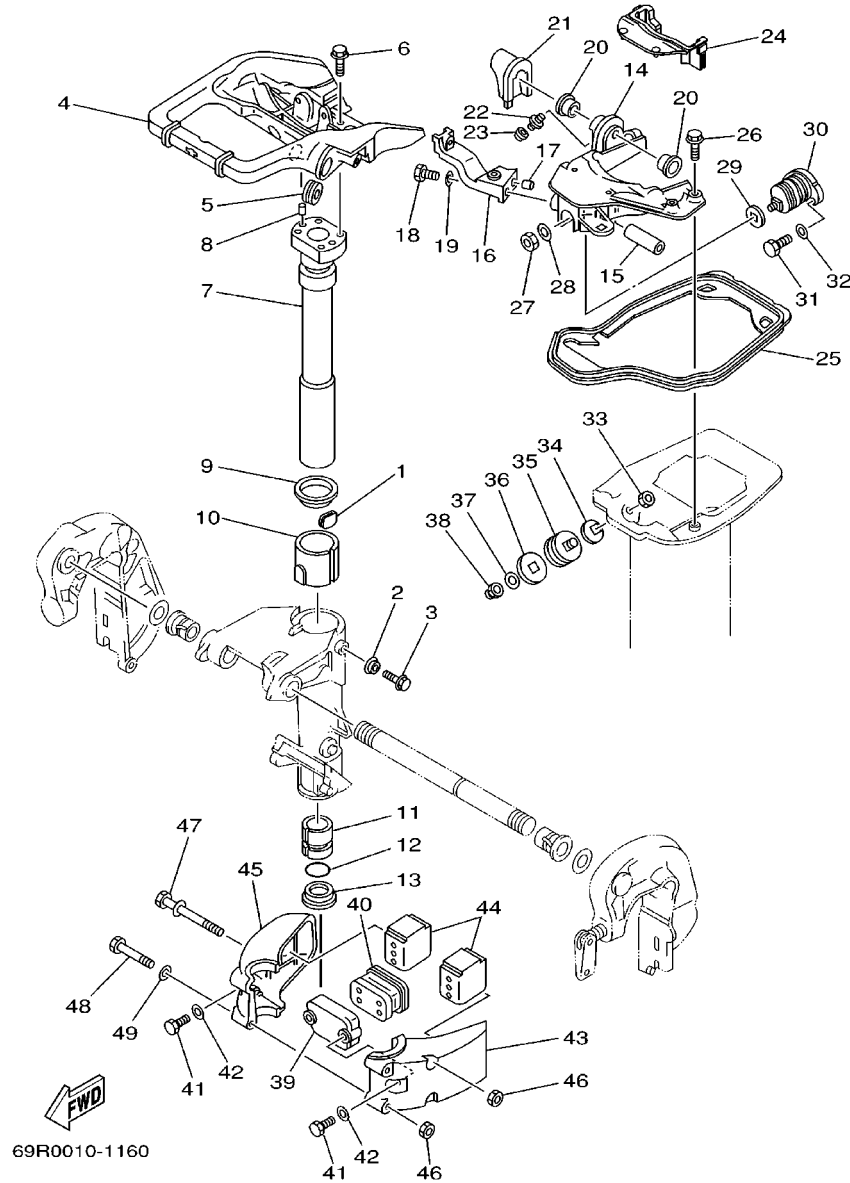

69R0010-1160

REF. NO.	PART NO. CODIGO NO.	DESCRIPTION DESCRIPTION	MH	WH	W	REMARKS OBSERVACION
28	92990-10200	WASHER, PLAIN ARANDELA	1	1	1	
29	648-44591-00	GASKET EMPAQUE, AMORTIGUADOR	1	1	1	
30	689-44516-00	MOUNT DAMPER, UPPER FRONT AMORTIGUADOR DE HULE FRENTE SU	1	1	1	
31	97095-06020	BOLT PERNO	2	2	2	
32	92995-06600	WASHER ARANDELA	2	2	2	
33	90170-10M42	NUT TUERCA	2	2	2	
34	648-44591-00	GASKET EMPAQUE, AMORTIGUADOR	2	2	2	
35	664-44514-00-94	MOUNT DAMPER, UPPER SIDE AMORTIGUADOR LADO SUPERIOR	2	2	2	
36	664-44591-00	GASKET EMPAQUE, AMORTIGUADOR	2	2	2	
37	92990-10200	WASHER, PLAIN ARANDELA	2	2	2	
38	90176-10M01	NUT, CROWN TUERCA CORONA	2	2	2	
39	689-44553-00-94	COVER, LOWER MOUNT CUBIERTA, AMORTIGUADOR INFERIOR	1	1	1	
40	689-44557-00	MOUNT DAMPER, LOWER FRONT AMORTIGUADOR DE HULE FRENTE IN	1	1	1	
41	97075-08025	BOLT PERNO	2	2	2	
42	92995-08600	WASHER ARANDELA	2	2	2	
43	689-44551-01-4D	HOUSING, LOWER MOUNT RUBBER CAJA AMORTIGUADOR INFERIOR HU	1	1	1	
44	689-44555-00	MOUNT DAMPER, LOWER SIDE AMORTIGUADOR DE HULE LADO INFE	2	2	2	
45	689-44552-01-4D	HOUSING, LOWER MOUNT RUBBER CAJA AMORTIGUADOR INFERIOR HU	1	1	1	
46	95380-08600	NUT TUERCA	4	4	4	
47	90119-08M03	BOLT, WITH WASHER TORNILLO CON ARANDELA	2	2	2	
48	97095-08065	BOLT PERNO	2	2	2	
49	92995-08600	WASHER ARANDELA	2	2	2	

FIG. 19 UPPER CASING

FUNDA SUPERIOR

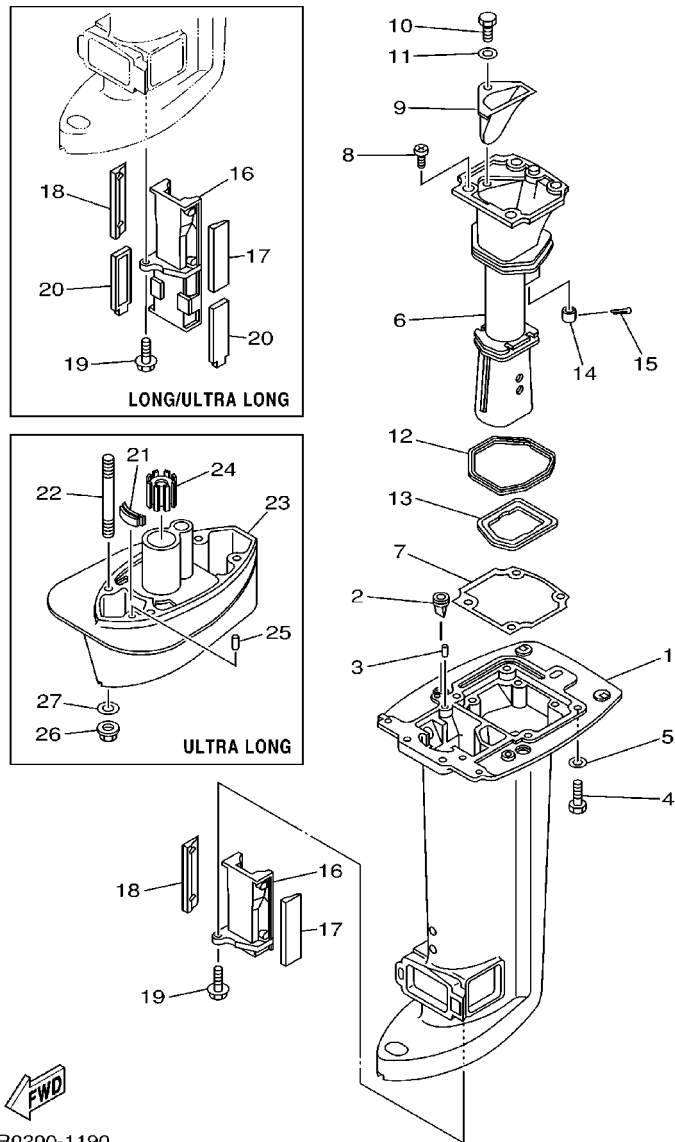

69R0200-1190

REF. NO.	PART NO. CODIGO NO.	DESCRIPTION DESCRIPTION	MH	WH	W	REMARKS OBSERVACION
1	69P-45111-00-4D	CASING, UPPER CAJA SUPERIOR	1		1	S
	69P-45111-10-4D	CASING, UPPER CAJA SUPERIOR	1	1	1	L,X
2	65W-42717-00	RUBBER, SEAL 2 GOMA	2	2	2	
3	93606-12019	PIN, DOWEL PASADOR DE CLAVIJA	2	2	2	
4	97075-08030	BOLT PERNO	6	6	6	
5	92995-08600	WASHER ARANDELA	6	6	6	
6	69P-41131-10-5B	MANIFOLD, EXT. 1 TUBO MULTIPLE DE ESCAPE	1	1	1	
7	69P-41134-A0	GASKET, EXHAUST MANIFOLD EMPAQUE	1	1	1	
8	97880-06016	SCREW, PAN HEAD TORNILLO DE CABEZA CON PLANA	4	4	4	
9	69P-41137-00-5B	GUIDE, EXHAUST GUIA DE ESCAPE	1	1	1	
10	97095-08020	BOLT PERNO	1	1	1	
11	92995-08600	WASHER ARANDELA	1	1	1	
12	69P-41138-00	SEAL, EXT. 1 SELLO, ESCAPE 1	1	1	1	
13	69P-41139-00	SEAL, EXT. 2 SELLO, ESCAPE 2	1	1	1	
14	6A8-41135-00	GASKET, EXHAUST MANIFOLD EMPAQUE	1	1	1	
15	91490-30025	PIN, COTTER PASADOR DE CHAVETA	1	1	1	
16	69P-47467-00-5B	PLATE, GUIDE PLACA DE GUIA	1		1	S
	69P-47467-10-5B	PLATE, GUIDE PLACA DE GUIA	1	1	1	L,X
17	69P-45127-00	SEAL SELLO DE GOMA	1	1	1	
18	69P-45128-00	SEAL 2 SELLO DE GOMA 2	1	1	1	
19	90119-06024	BOLT, WITH WASHER TORNILLO CON ARANDELA	1	1	1	
20	69P-45159-00	DAMPER SELLO DE GOMA	2	2	2	L,X
21	61N-45375-00	DAMPER, SEAL GOMA DE SELLO	1			X
22	90116-10M33	BOLT, STUD ESPARRAGO	4			X
23	61N-45211-31-4D	EXTENSION EXTENSION	1			X
24	689-45318-00	BUSHING, DRIVE SHAFT BUJE, EJE DE MANDO	1			X
25	93606-11M24	PIN, DOWEL PASADOR DE CLAVIJA	2			X

FIG. 19 UPPER CASING

FUNDA SUPERIOR

REF. NO.	PART NO. CODIGO NO.	DESCRIPTION DESCRIPTION	MH	WH	W			REMARKS OBSERVACION
26	90179-10M03	NUT TUERCA	4					X
27	92995-10600	WASHER ARANDELA	4					X

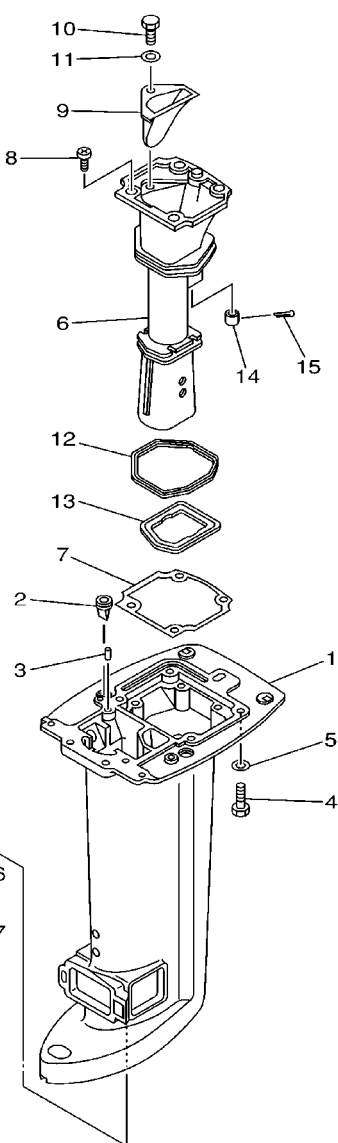
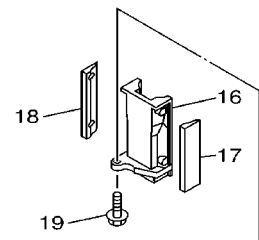
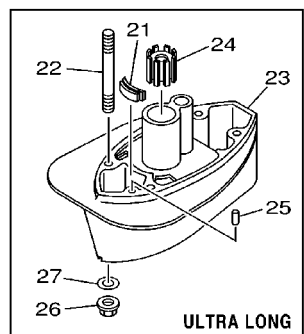
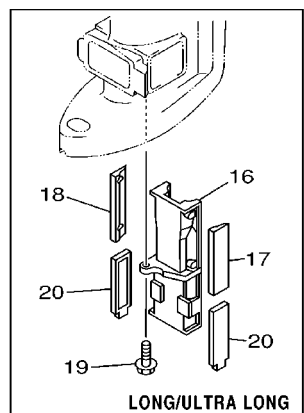

69R0200-1190

FIG. 20 LOWER CASING, DRIVE 1

IMPULSOR E INFERIOR 1

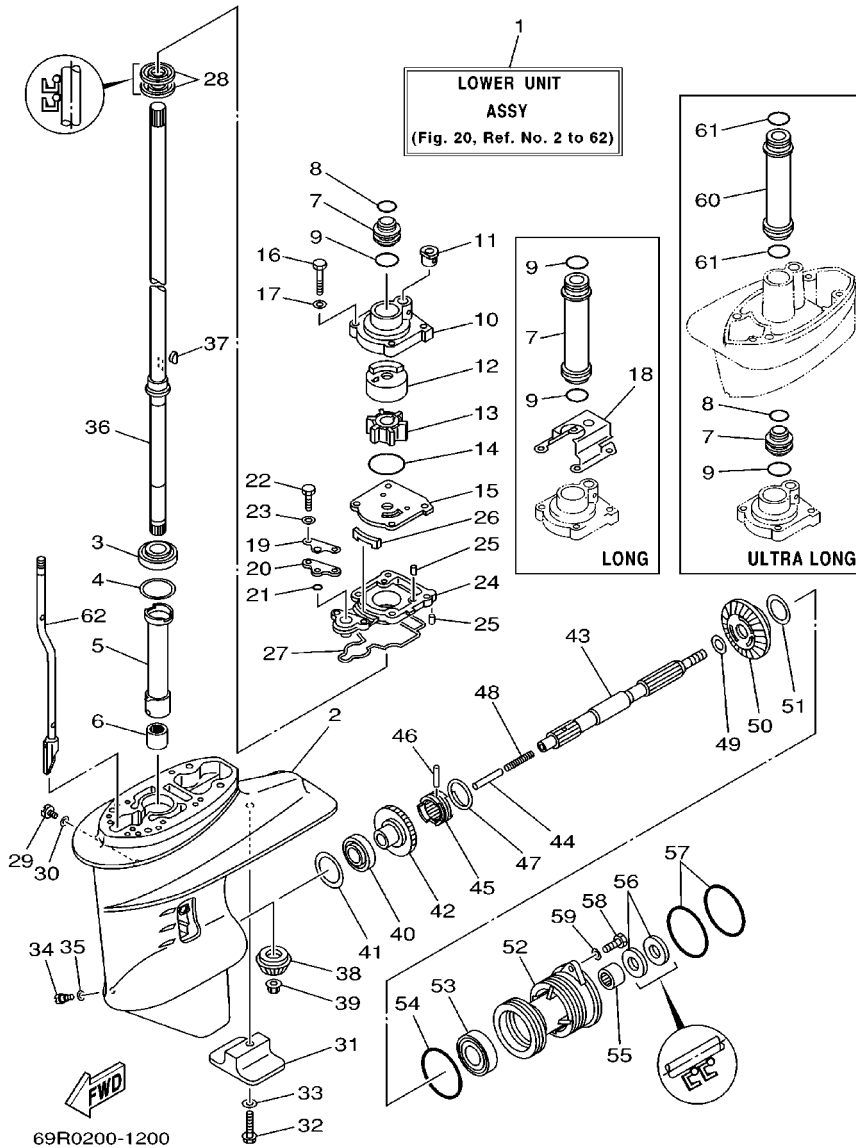

REF. NO.	PART NO. CODIGO NO.	DESCRIPTION DESCRIPTION	MH	WH	W	REMARKS OBSERVACION
1	69P-45300-00-4D	LOWER UNIT ASSY CONJUNTO UNIDAD INFERIOR	1		1	S
	69P-45300-10-4D	LOWER UNIT ASSY CONJUNTO UNIDAD INFERIOR	1	1	1	L
	69P-45300-30-4D	LOWER UNIT ASSY CONJUNTO UNIDAD INFERIOR	1			X
2	61N-45311-02-4D	CASING, LOWER FUNDA INFERIOR	1	1	1	
3	93332-000W5	BEARING COJINETE	1	1	1	
4	61N-45587-00-07	SHIM (T:0.7MM) LAMINILLA DE AJUSTE (T:0.7MM)	1	1	1	UR
	61N-45587-00-10	SHIM (T:1.0MM) LAMINILLA DE AJUSTE (T:1.0MM)	1	1	1	UR
	61N-45587-00-11	SHIM (T:1.1MM) LAMINILLA DE AJUSTE (T:1.1MM)	1	1	1	UR
	61N-45587-00-12	SHIM (T:1.2MM) LAMINILLA DE AJUSTE (T:1.2MM)	1	1	1	UR
	61N-45587-00-13	SHIM (T:1.3MM) LAMINILLA DE AJUSTE (T:1.3MM)	1	1	1	UR
	61N-45587-00-14	SHIM (T:1.4MM) LAMINILLA DE AJUSTE (T:1.4MM)	1	1	1	UR
	61N-45587-00-15	SHIM (T:1.5MM) LAMINILLA DE AJUSTE (T:1.5MM)	1	1	1	UR
	61N-45587-00-16	SHIM (T:1.6MM) LAMINILLA DE AJUSTE (T:1.6MM)	1	1	1	UR
5	61N-45536-00	SLEEVE, DRIVE SHAFT CAMISA EJE DE MANDO	1	1	1	
6	93315-220V7	BEARING COJINETE	1	1	1	
7	61N-44362-00	TUBE, WATER TUBO DE AGUA	1		1	S,X
	61N-44362-10	TUBE, WATER TUBO DE AGUA	1	1	1	L
8	93210-22164	O-RING ANILLO O	1		1	S,X
9	93210-26130	O-RING ANILLO O	1		1	S,X
	93210-26130	O-RING ANILLO O	2	2	2	L
10	69P-44311-00	HOUSING, WATER PUMP CAJA BOMBA DE AGUA	1	1	1	
11	6L2-44367-00	DAMPER, WATER SEAL GOMA DEL SELLO DE AGUA	1	1	1	
12	69P-44322-00	INSERT, CARTRIDGE CARTUCHO	1	1	1	FOR STD
	69P-44322-40	INSERT, CARTRIDGE CARTUCHO	1	1	1	FOR CHROMATE
13	6H4-44352-02	IMPELLER IMPULSOR	1	1	1	
14	93210-45161	O-RING ANILLO O	1	1	1	
15	61N-44323-00	OUTER PLATE, CARTRIDGE PLACA EXTERIOR DEL CARTUCHO	1	1	1	FOR STD

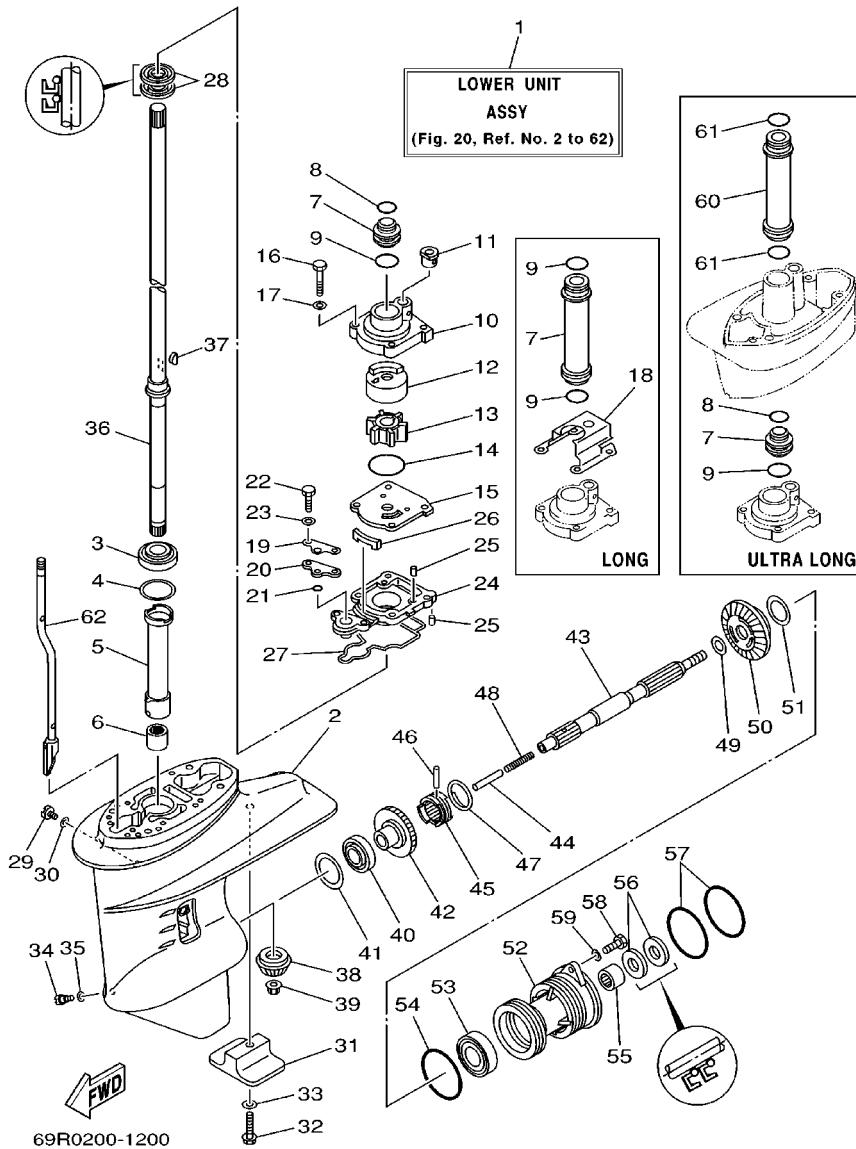
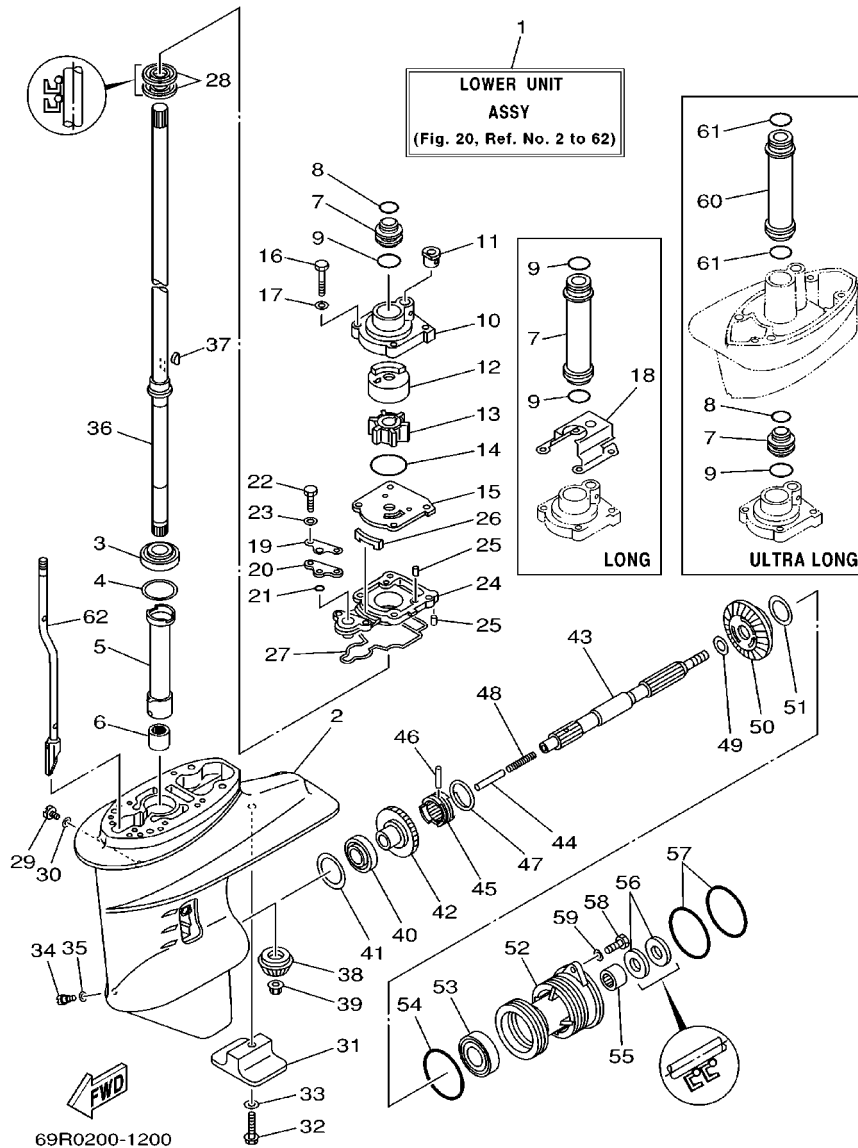

FIG. 20 LOWER CASING, DRIVE 1 IMPULSOR E INFERIOR 1

REF. NO.	PART NO. CODIGO NO.	DESCRIPTION DESCRIPTION	MH	WH	W	REMARKS OBSERVACION
15	61N-44323-40	OUTER PLATE, CARTRIDGE PLACA EXTERIOR DEL CARTUCHO	1	1	1	FOR CHROMATE
16	97095-06040	BOLT PERNO	4	4	4	
17	92995-06600	WASHER ARANDELA	4	4	4	
18	65W-44328-10	PLATE PLACA	1	1	1	L
19	61N-44176-00	BRACKET SOPORTE	1	1	1	
20	61N-45321-00	PLATE PLACA	1	1	1	
21	93210-06ME6	O-RING ANILLO O	1	1	1	
22	97095-06025	BOLT PERNO	2	2	2	
23	92995-06600	WASHER ARANDELA	2	2	2	
24	61N-45331-00-5B	HOUSING, BEARING CAJA DE COJINETE	1	1	1	
25	93604-10M03	PIN, DOWEL PASADOR DE CLAVIJA	3	3	3	
26	61N-45127-00	SEAL SELLO DE GOMA	1	1	1	
27	61N-45315-00	PACKING, LOWER CASING EMPAQUE	1	1	1	
28	93101-22067	OIL SEAL SELLO ACEITE	2	2	2	
29	90340-08M04	PLUG, STRAIGHT SCREW TORNILLO DE DRENAJE	1	1	1	
30	90430-08020	GASKET JUNTA	1	1	1	
31	61N-45251-00	ANODE CATODE	1	1	1	
32	95895-06035	BOLT, FLANGE TUERCA DE REBORDE	1	1	1	
33	92990-06300	WASHER, INTERNAL TOOTH ARANDELA	1	1	1	
34	688-45341-00	PLUG, DRAIN TAPON, DREN	1	1	1	
35	90430-08020	GASKET JUNTA	1	1	1	
36	61N-45510-00	DRIVE SHAFT ASSY EJE DE MANDO COMPL.	1	1	1	S
	61N-45510-10	DRIVE SHAFT ASSY EJE DE MANDO COMPL.	1	1	1	L
	61N-45510-30	DRIVE SHAFT ASSY EJE DE MANDO COMPL.	1	1	1	X
37	90280-03M03	KEY, WOODRUFF CUNA WOODRUFF	1	1	1	
38	61N-45551-00	PINION PINON	1	1	1	
39	90179-10M14	NUT TUERCA	1	1	1	

FIG. 20 LOWER CASING, DRIVE 1

IMPULSOR E INFERIOR 1



REF. NO.	PART NO. CODIGO NO.	DESCRIPTION DESCRIPTION	MH	WH	W	REMARKS OBSERVACION
40	93332-00005	BEARING COJINETE	1	1	1	
41	6L2-45567-00-10	SHIM (T:1.0MM) LAINA (T:1.0MM)	1	1	1	UR
	6L2-45567-00-11	SHIM (T:1.1MM) LAINA (T:1.1MM)	1	1	1	UR
	6L2-45567-00-12	SHIM (T:1.2MM) LAINA (T:1.2MM)	1	1	1	UR
	6L2-45567-00-13	SHIM (T:1.3MM) LAINA (T:1.3MM)	1	1	1	UR
	6L2-45567-00-14	SHIM (T:1.4MM) LAINA (T:1.4MM)	1	1	1	UR
42	61N-45560-00	GEAR ENGRANE COMPLE 1	1	1	1	
43	6L2-45611-00	SHAFT, PROPELLER EJE PROPUSOR	1	1	1	
44	648-45635-00	PLUNGER, SHIFT EMBOLO DE CAMBIO	1	1	1	
45	664-45631-02	CLUTCH, DOG EMBRAGUE DE GARRA	1	1	1	
46	90250-05010	PIN, STRAIGHT PASADOR CILINDRICO	1	1	1	
47	648-45633-00	RING, CROSS PIN ANILLO DE PASADOR	1	1	1	
48	90501-10065	SPRING, COMPRESSION RESORTE DE COMPRESION	1	1	1	
49	90201-20417	WASHER, PLATE ARANDELA PLANA	1	1	1	
50	61N-45571-00	GEAR ENGRANAJE	1	1	1	
51	6L2-45577-00-10	SHIM (T:1.0MM) LAINA (T:1.0MM)	1	1	1	UR
	6L2-45577-00-11	SHIM (T:1.1MM) LAINA (T:1.1MM)	1	1	1	UR
	6L2-45577-00-12	SHIM (T:1.2MM) LAINA (T:1.2MM)	1	1	1	UR
	6L2-45577-00-13	SHIM (T:1.3MM) LAINA (T:1.3MM)	1	1	1	UR
52	61N-45361-01-4D	CAP, LOWER CASING FUNDA INFERIOR	1	1	1	
53	93306-00612	BEARING COJINETE	1	1	1	
54	93210-64ME7	O-RING ANILLO O	1	1	1	
55	93315-22004	BEARING COJINETE	1	1	1	
56	93101-20M07	OIL SEAL SELLO ACEITE	2	2	2	
57	93210-65M50	O-RING ANILLO O	2	2	2	
58	97075-06020	BOLT PERNO	2	2	2	
59	92995-06600	WASHER ARANDELA	2	2	2	

FIG. 20 LOWER CASING. DRIVE 1

IMPULSOR E INFERIOR 1

REF. NO.	PART NO. CODIGO NO.	DESCRIPTION DESCRIPTION	MH	WH	W	REMARKS OBSERVACION
60	61N-44362-10	TUBE, WATER TUBO DE AGUA	1			X
61	93210-26130	O-RING ANILLO O	2			X
62	61N-44150-00	SHIFT CAM ASSY CONJUNTO EJE LEVA COMPL.	1	1		S
	61N-44150-10	SHIFT CAM ASSY CONJUNTO EJE LEVA COMPL.	1	1	1	L
	61N-44150-30	SHIFT CAM ASSY CONJUNTO EJE LEVA COMPL.	1			X

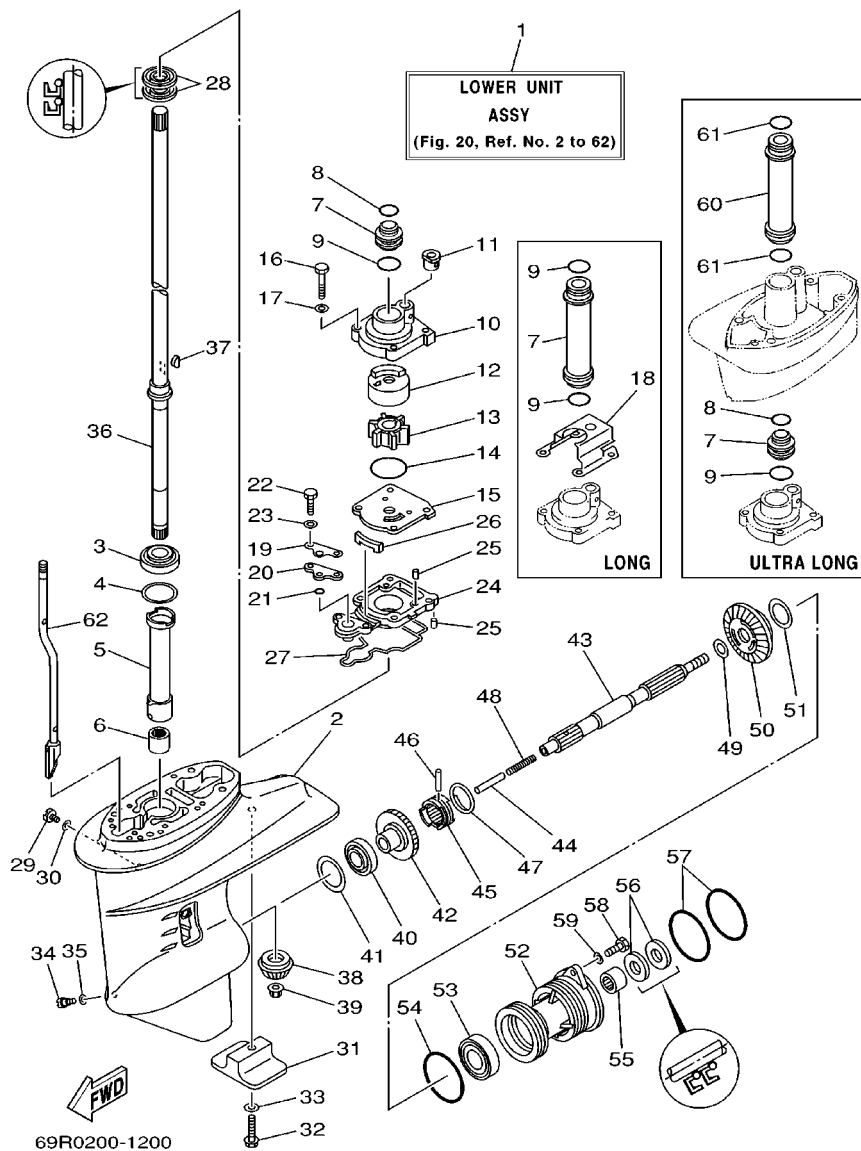
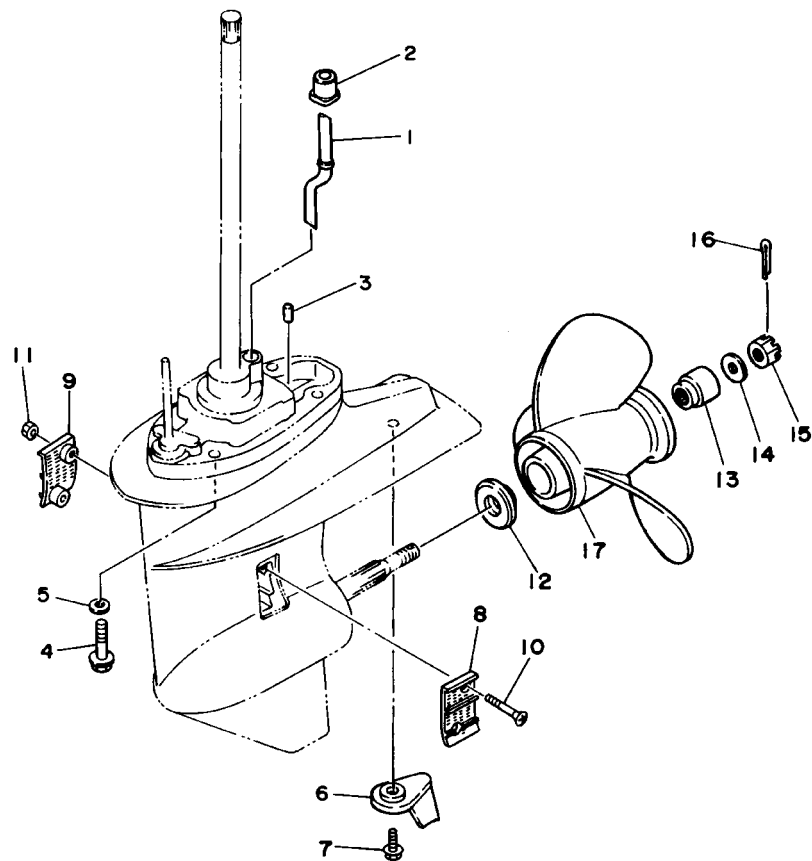

FIG. 21 LOWER CASING, DRIVE 2

IMPULSOR E INFERIOR 2



REF. NO.	PART NO. CODIGO NO.	DESCRIPTION DESCRIPTION	MH	WH	W	REMARKS OBSERVACION
1	61N-44361-00	TUBE, WATER TUBO DE AGUA	1		1	S
	61N-44361-10	TUBE, WATER TUBO DE AGUA	1	1	1	L
	61N-44361-30	TUBE, WATER TUBO DE AGUA	1			X
2	689-44366-00	DAMPER, WATER SEAL GOMA DEL SELLO DE AGUA	1	1	1	
3	93606-11M24	PIN, DOWEL PASADOR DE CLAVIJA	2	2	2	
4	90105-10M12	BOLT, WASHER BASED TORNILLO CON ARANDELA	4	4	4	S,L
5	92995-10600	WASHER ARANDELA	4	4	4	S,L
6	61N-45371-00	TAB-TRIM QUILLA ESTABILIZADOR	1	1	1	
7	90119-06M48	BOLT, WITH WASHER TORNILLO CON ARANDELA	1	1	1	
8	6L2-45214-00	COVER, WATER INLET CUBIERTA ENTRADA AGUA	1	1	1	
9	6L2-45215-00	COVER, WATER INLET CUBIERTA ENTRADA AGUA	1	1	1	
10	90151-05M05	SCREW, COUNTERSUNK TORNILLO EMBUTIDO	2	2	2	
11	90185-05002	NUT, SELF-LOCKING TUERCA AUTOBLOCANTE	2	2	2	
12	6L2-45987-01	SPACER ESPACIADOR	1	1	1	
13	689-45997-00	SPACER ESPACIADOR	1	1	1	
14	92990-14200	WASHER, PLAIN ARANDELA	1	1	1	
15	90171-14013	NUT, CASTLE TUERCA ENTALLADA	1	1	1	
16	91490-30022	PIN, COTTER PASADOR DE CHAVETA	1	1	1	
17	664-45941-01-EL	PROPELLER (3X9-7/8"X9"-F) PROPELA (3X9-7/8"X9"-F)	1	1	1	UR
	664-45943-01-EL	PROPELLER (3X9-7/8"X8"-F) PROPELA (3X9-7/8"X8"-F)	1	1	1	UR
	664-45945-00-EL	PROPELLER (3X9-7/8"X10-1/2"-F) PROPELA (3X9-7/8"X10-1/2"-F)	1	1	1	UR
	664-45947-01-EL	PROPELLER (3X9-7/8"X11-1/4"-F) PROPELA (3X9-7/8"X11-1/4"-F)	1	1	1	UR
	664-45949-02-EL	PROPELLER (3X9-7/8"X13"-F) PROPELA (3X9-7/8"X13"-F)	1	1	1	UR
	664-45952-00-EL	PROPELLER (3X9-7/8"X14"-F) PROPELA (3X9-7/8"X14"-F)	1	1	1	UR
	664-45954-01-EL	PROPELLER (3X9-7/8"X12"-F) PROPELA (3X9-7/8"X12"-F)	1	1	1	UR
	62C-45941-00-EL	PROPELLER (3X9-7/8"X10"-F) PROPELA (3X9-7/8"X10"-F)	1	1	1	UR



61R0010-4180

FIG. 22 FUEL TANK

DEPOSITO DE COMBUSTIBLE

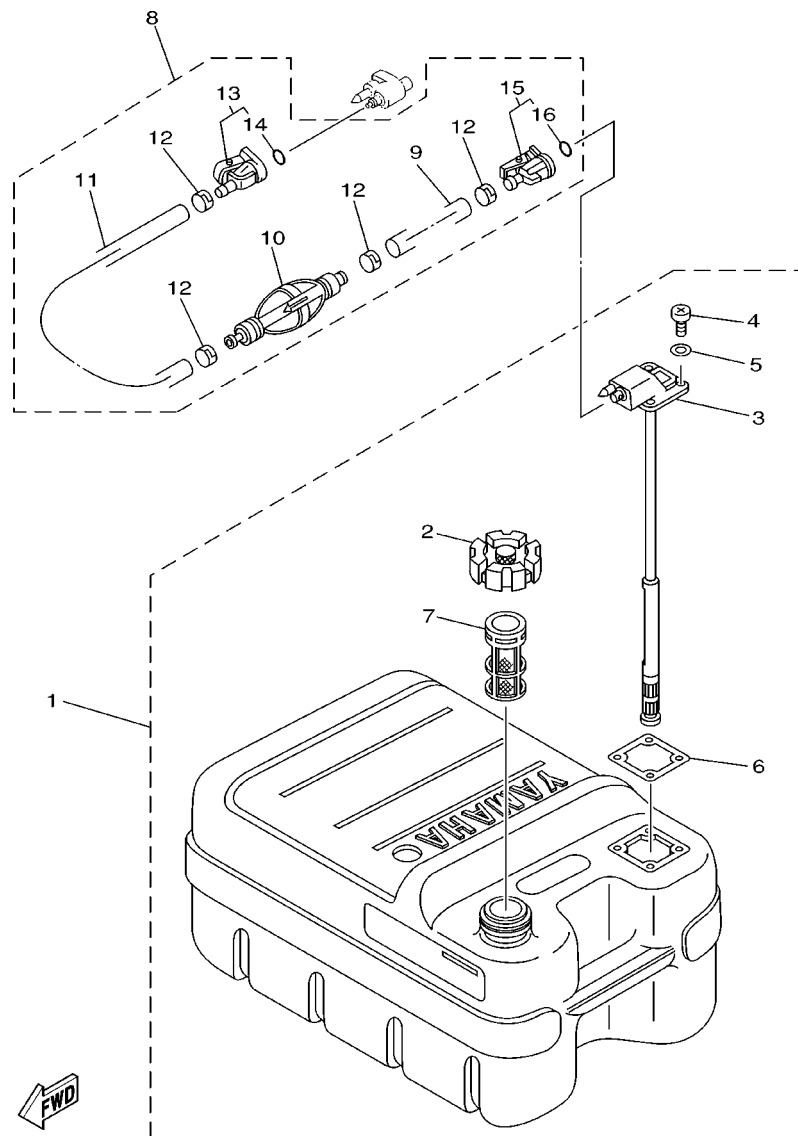

66T0100-9240

REF. NO.	PART NO. CODIGO NO.	DESCRIPTION DESCRIPTION	MH	WH	W	REMARKS OBSERVACION
1	6YJ-24201-00	FUEL TANK ASSY (24L)	1	1	1	AP
	6YJ-24201-10	TANQUE DEL COMBUSTIBLE (24L)	1	1	1	AP FOR CHINA WITH INDCATOR
2	6YJ-24610-01	.CAP ASSY	1	1	1	
		.TAPA COMPLETA				
3	6YJ-24260-00	.FUEL METER ASSY	1	1	1	
		.MEDIDOR DE COMBUSTIBLE COMPL.				
	6Y1-24260-12	.FUEL METER ASSY	1	1	1	FOR CHINA WITH INDCATOR
		.MEDIDOR DE COMBUSTIBLE COMPL.				
4	98586-05016	.SCREW, PAN HEAD	4	4	4	
5	6Y1-24329-00	.SEAL	4	4	4	
		.SELLO				
6	6Y1-24268-00	.GASKET, FUEL METER	1	1	1	
		.EMPAQ MEDIDOR DE COMBUSTIBLE				
7	6YJ-24167-00	.STRAINER	1	1	1	
		.COLADOR				
8	61J-24306-02	FUEL PIPE COMP. 1	1	1	1	AP
		TUBO COMBUST. COMPL 1				
9	90445-11M06	.HOSE (L2050)	1	1	1	
		.MANGUERA (L2050)				
10	61J-24360-00	.PRIMER PUMP ASSY	1	1	1	
		.SOPORTE BOMBA				
11	90445-11M05	.HOSE (L:850MM)	1	1	1	
		.MANGUERA (L:850MM)				
12	650-24351-51	BAND 1	4	4	4	
		.ABRAZADERA 1				
13	6G1-24305-03	FUEL PIPE JOINT COMP. 2	1	1	1	
		.CONECTOR MANGUERA COMBUST.2				
14	93210-08287	.O-RING	1	1	1	
		.ANILLO O				
15	6Y1-24305-04	FUEL PIPE JOINT COMP. 2	1	1	1	
		.CONECTOR MANGUERA COMBUST.2				
16	93210-08287	.O-RING	1	1	1	
		.ANILLO O				

FIG. 23 STEERING GUIDE

DIRECCIONGUIAR

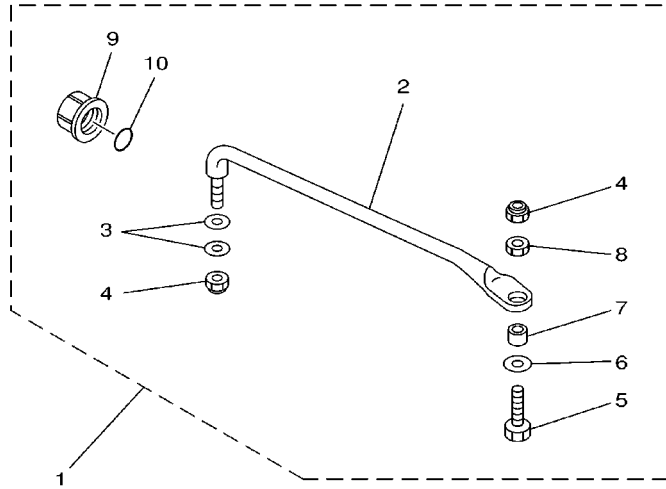

6J80ACC-0030

REF. NO.	PART NO. CODIGO NO.	DESCRIPTION DESCRIPTION	MH	WH	W	REMARKS OBSERVACION
1	689-61350-02	STEERING GUIDE ATTACHMENT KIT ESTUCHE ADITAMENTO GUIA DE TIM			1	AP FOR CHINA
2	689-61351-01	.ROD, STEERING LINK .VARILLA ESLABON DIRECCION			1	
3	90201-10M20	.WASHER, PLATE .ARANDELA PLANA			2	
4	90185-09M01	.NUT, SELF-LOCKING .TUERCA AUTOBLOCANTE			2	
5	6E5-61355-00	.BOLT .TORNILLO			1	
6	90201-10M63	.WASHER, PLATE .ARANDELA PLANA			1	
7	90387-10M42	.COLLAR .COLLAR			1	
8	90170-09M03	.NUT .TUERCA			1	
9	6E5-43145-01	.CAP, CLAMP BRACKET .TAPA			1	
10	93210-16275	.O-RING .ANILLO O			1	

FIG. 24 REMOTE CONTROL BOX CONTROL REMOTO COMPL.

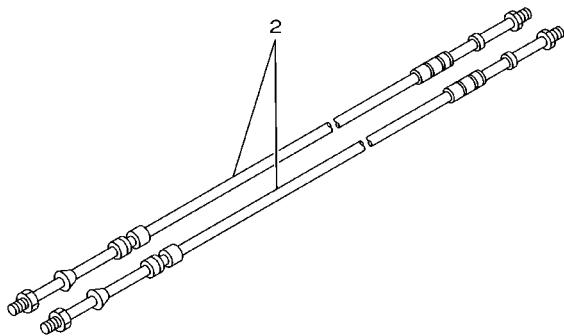
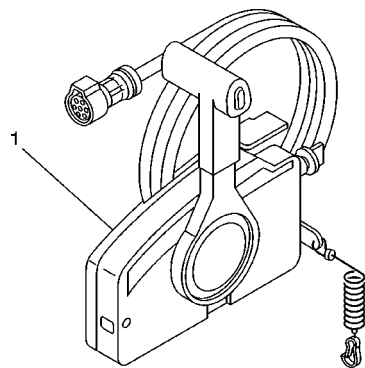

67M0100-8280

REF. NO.	PART NO. CODIGO NO.	DESCRIPTION DESCRIPTION	MH	WH	W	REMARKS OBSERVACION
1	703-48230-14	REMOTE CONTROL ASSY (7P) CONTROL REMOTO COMPL. (7P)			1	AP
2	701-48320-20	CABLE, REMOTE CONTROL L=13F CABLE CONTROL REMOTO L=13F			2	UR
	701-48320-50	CABLE, REMOTE CONTROL L=15F CABLE CONTROL REMOTO L=15F			2	UR

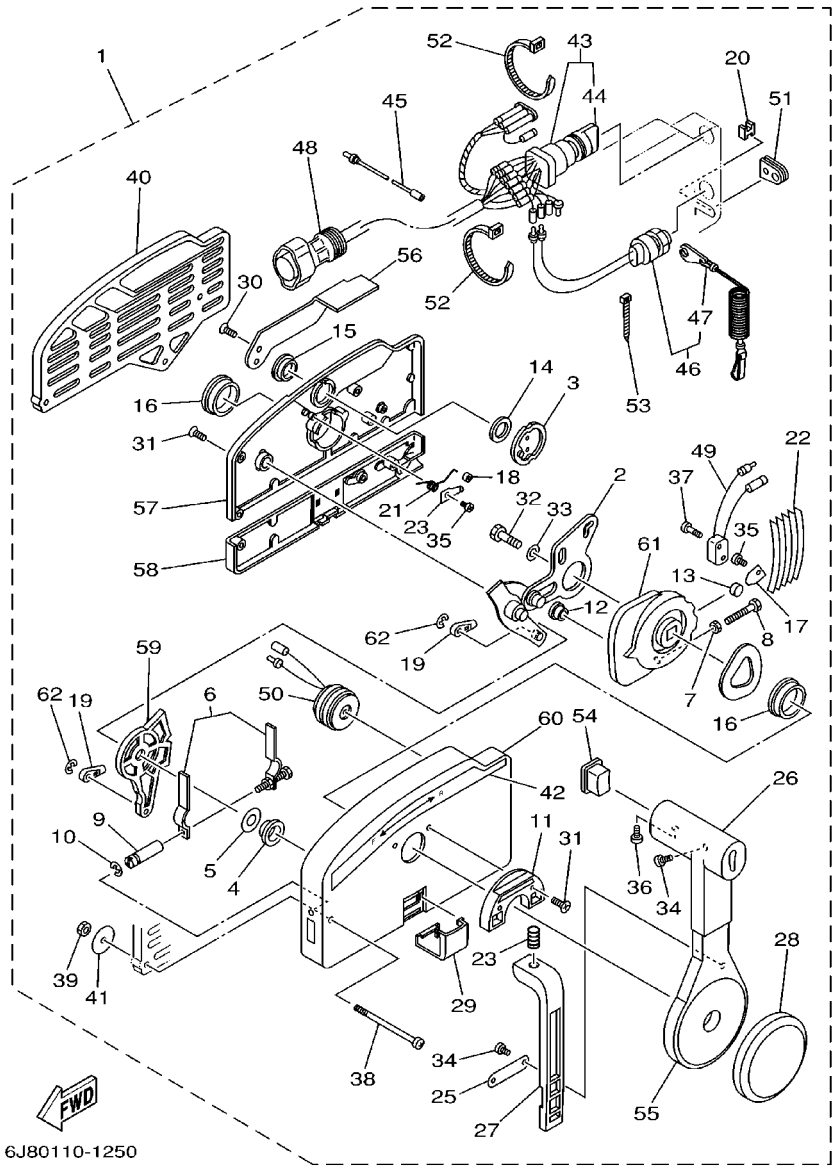

6J80110-1250

FIG. 25 REMOTE CONTROL ASSY CONTROL REMOTO COMPL.

REF. NO.	PART NO. CODIGO NO.	DESCRIPTION DESCRIPTION	MH	WH	W	REMARKS OBSERVACION
1	703-48230-14	REMOTE CONTROL ASSY (7P) CONTROL REMOTO COMPL. (7P)			1	AP
2	703-48261-11	.ARM, THROTTLE .BRAZO ACELERADOR			1	
3	703-48153-00	.SHAFT, FREE ACCEL. .EJE			1	
4	703-48235-00	.BUSHING .BUJE			1	
5	703-48268-00	.SPACER .ESPACIADOR 3			1	
6	703-48264-00	.THROTTLE, FRICTION .FRICCION ACELERADOR			1	
7	95380-05600	.NUT .TUERCA			1	
8	97380-05025	.BOLT .PERNO			1	
9	703-48265-00	.SHAFT, FRICTION .EJE FRICCION			1	
10	93430-06024	.CIRCLIP .BOLA			3	
11	703-48245-00	.PLATE, LOCK .PLACA CERRADURA			1	
12	703-48252-00	.ROLLER, CAM .RODILLO LEVA			1	
13	701-48248-00	.ROLLER, FREE ACCEL. .RODILLO ACELERADOR LIBRE			1	
14	703-48198-00	.WASHER, WAVE .RONDANA ONDULADA 3			1	
15	703-48243-00	.BUSHING .BUJE 3			1	
16	703-48236-00	.BUSHING 1 .BUJE			2	
17	703-48189-00	.RETAINER .RETENEDOR			1	
18	703-48234-00	.ROLLER, DETENT .RODILLO			1	
19	703-48345-01	.CABLE END,REMOTE CONTROL 2 .TERMINAL CABLE DE CONTROL REM			2	
20	703-48358-00	.ANCHOR, CABLE .ABRAZADERA CABLE			1	
21	703-48244-00	.SPRING, FREE ACCEL. .RESORTE ACELERADOR LIBRE			1	
22	703-48238-00	.SPRING, DETENT .RESORTE			5	
23	703-48246-00	.SPACER .ESPACIADOR			1	
24	703-48227-00	.SPRING, NEUTRAL LOCK .RESORTE DE SEGURO			1	
25	703-48226-00	.PLATE, STOPPER .PLACA RETEN			1	
26	703-48222-00	.GRIP, CONTROL LEVER .MANGO DE PALANCA CONTROL			1	SINGLE
27	703-48223-00	.LOCK, NEUTRAL .CERRADURA NEUTRO			1	

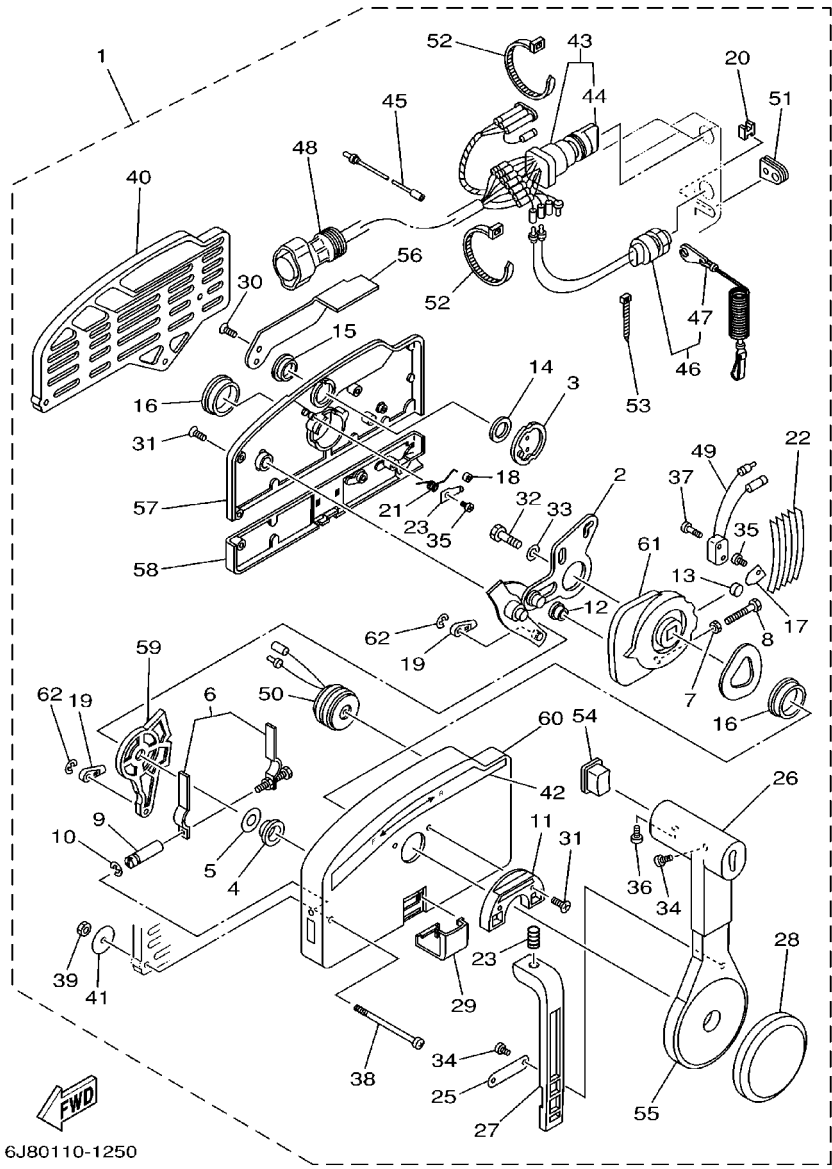

6J80110-1250

FIG. 25 REMOTE CONTROL ASSY CONTROL REMOTO COMPL.

REF. NO.	PART NO. CODIGO NO.	DESCRIPTION DESCRIPTION	MH	WH	W	REMARKS OBSERVACION
28	703-48225-00	.COVER .CUBIERTA			1	
29	703-48219-00	.COVER, LEAD .CUBIERTA			1	
30	703-48281-00	.SCREW .TORNILLO 1			2	
31	703-48282-00	.SCREW .TORNILLO 2			7	
32	97095-08030	.BOLT .PERNO			1	
33	92990-08600	.WASHER, PLATE .ARANDELA			1	
34	98580-04010	.SCREW, PAN HEAD .TORNILLO DE CABEZA CON PLANA			3	
35	98580-04006	.SCREW, PAN HEAD .TORNILLO DE CABEZA CON PLANA			2	
36	98580-05010	.SCREW, PAN HEAD .TORNILLO DE CABEZA CON PLANA			1	
37	98580-03015	.SCREW, PAN HEAD .TORNILLO DE CABEZA CON PLANA			2	
38	703-48291-10	.SCREW (M6) .TORNILLO (M6)			3	
39	95380-06600	.NUT, HEXAGON .TUERCA			3	
40	703-48293-10	.SPACER, REMOTE CONTROL .ESPACIADOR			1	SINGLE
41	701-48287-00	.WASHER .ARANDELA			3	
42	703-48215-00	.GRAPHIC .CALCOMANIA 1			1	
43	703-82510-31	.MAIN SWITCH ASSY (7P) .CONJUNTO DE LLAVE IGNICION (7P)			1	
44	676-82577-00	.CAP, KEY .TAPA			1	
45	703-82531-00	.WIRE, LEAD .CABLE CONDUCTOR			1	
46	688-82575-01	.ENGINE STOP SWITCH ASSY .INTERRUPTOR DE PARADA COMPL			1	
47	682-82556-00	.STOPPER .RETEN			1	
48	688-82586-21	.EXTENSION, WIRE HARNESS .EXTENSION, CONJ. DE CABLES			1	L:5M (7P)
49	703-82540-00	.NEUTRAL SWITCH ASSY .INTERRUPTOR NEUTRAL COMPL			1	
50	703-83383-02	.BUZZER .ZUMBADOR			1	
51	703-48284-00	.GROMMET .TAPON 1			1	
52	703-82591-00	.BAND .BANDA			2	
53	703-82592-00	.BAND .BANDA			1	
54	703-48224-00	.COVER, CONTROL LEVER .CUBIERTA DE PALANCA CONTROL			1	WITHOUT PT/T SW.

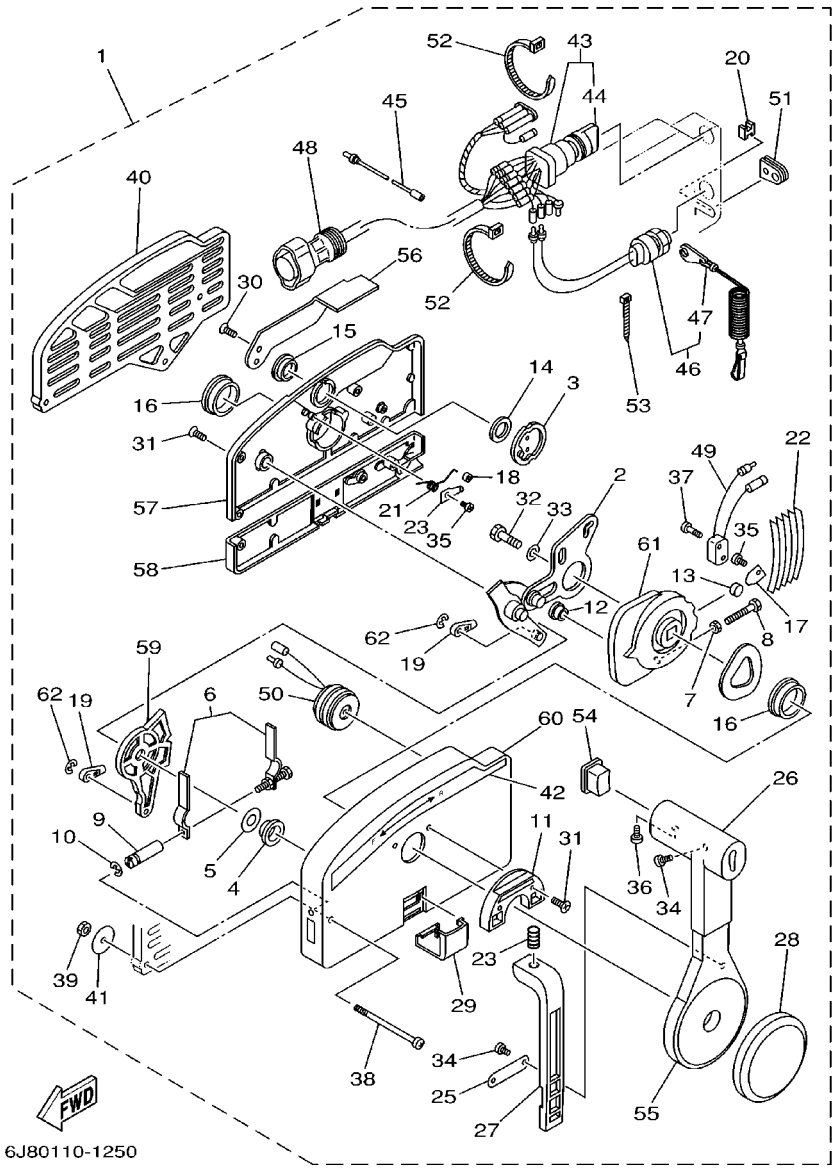

6J80110-1250

FIG. 25 REMOTE CONTROL ASSY CONTROL REMOTO COMPL.

REF. NO.	PART NO. CODIGO NO.	DESCRIPTION DESCRIPTION	MH	WH	W	REMARKS OBSERVACION
55	703-48221-00	.LEVER, CONTROL .PALANCA CONTROL			1	
56	703-48152-00	.KNOB, FREE ACCEL. .PERILLA			1	
57	703-48212-00	.BACK PLATE 1 .PLACA TRASERA 1			1	
58	703-48213-00	.BACK PLATE 2 .PLACA TRASERA 2			1	
59	703-48271-00	.ARM, SHIFT .BRAZO CAMBIADOR			1	
60	703-48211-01	.HOUSING,1 .CAJA			1	
61	703-48232-00	.GEAR .ENGRANAJE 1			1	
62	93430-06024	.CIRCLIP .BOLA			2	

FIG. 26 REPAIR KIT 1

ESTUCHE REPARATION 1

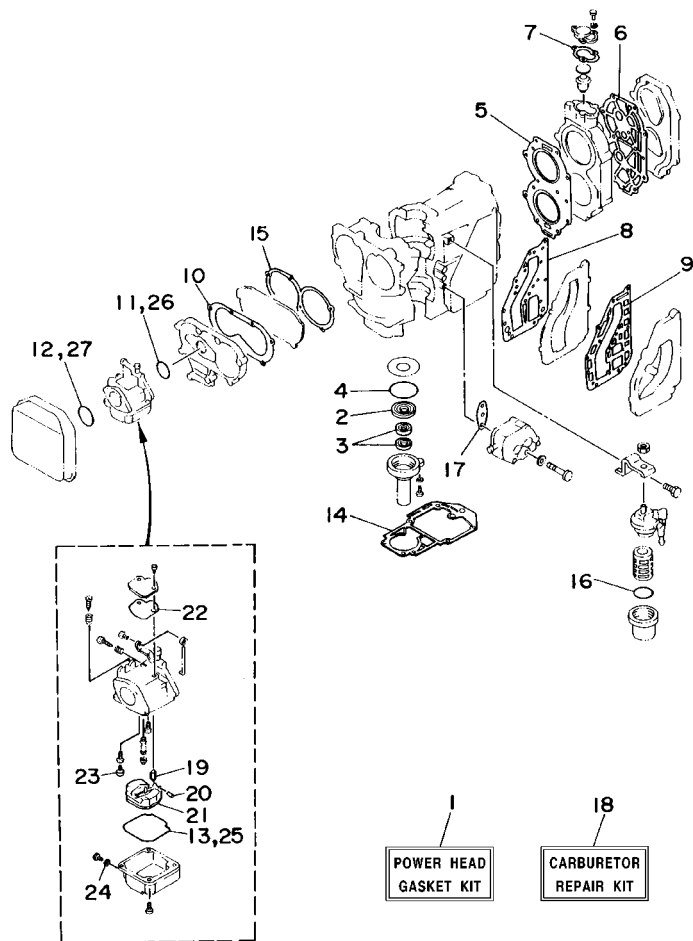

REF. NO.	PART NO. CODIGO NO.	DESCRIPTION DESCRIPTION	MH	WH	W	REMARKS OBSERVACION
1	69P-W0001-00	POWER HEAD GASKET KIT JUEGO DE EMPAQUE DE MOTOR	1	1	1	
2	93102-25008	.OIL SEAL .SELLO ACEITE	1	1	1	
3	93101-16001	.OIL SEAL .SELLO ACEITE	2	2	2	
4	93210-58M21	.O-RING ANILLO O	1	1	1	
5	61N-11181-A1	.GASKET, CYLINDER HEAD 1 JUNTA, DE CULATA 1	1	1	1	
6	61T-11193-A1	.GASKET, HEAD COVER 1 EMPAQUE	1	1	1	
7	655-12414-A1	.GASKET, COVER EMPAQUE	1	1	1	
8	6K8-41122-A1	.GASKET, EXHAUST INNER COVER EMPAQUE	1	1	1	
9	6K8-41124-A1	.GASKET, EXHAUST OUTER COVER EMPAQUE	1	1	1	
10	648-13645-A0	.GASKET, MANIFOLD 1 EMPAQUE	1	1	1	
11	61N-14198-00	.GASKET EMPAQUE	1	1	1	
12	93210-40659	.O-RING ANILLO O	1	1	1	
13	6L2-14384-00	.GASKET, FLOAT CHAMBER EMPAQUE DE CAMARA DE BOIA	1	1	1	
14	689-45113-A1	.GASKET, UPPER CASING EMPAQUE	1	1	1	
15	648-13621-A1	.GASKET, VALVE SEAT JUNTA, DE VALV,DE EMPAQUE	1	1	1	
16	93210-32738	.O-RING ANILLO O	1	1	1	
17	650-24431-A0	.GASKET, FUEL PUMP 1 EMPAQUE BOMBA COMBUST 1	1	1	1	
18	61N-W0093-00	CARBURETOR REPAIR KIT KIT REPARACION CARBURADOR	1	1	1	
19	61N-14392-00	.VALVE, NEEDLE .VALVULA DE AGUJA	1	1	1	
20	6E5-14386-01	.PIN, FLOAT .PASADOR DE BOIA	1	1	1	
21	6L2-14385-00	.FLOAT BOIA	1	1	1	
22	6L2-14399-00	.GASKET EMPAQUE	1	1	1	
23	50M-14355-00	.PLUG .TAPON	1	1	1	
24	6L2-14398-00	.GASKET EMPAQUE	1	1	1	
25	6L2-14384-00	.GASKET, FLOAT CHAMBER EMPAQUE DE CAMARA DE BOIA	1	1	1	
26	61N-14198-00	.GASKET EMPAQUE	1	1	1	
27	93210-40659	.O-RING ANILLO O	1	1	1	

61R0700-4180

FIG. 27 REPAIR KIT 2

ESTUCHE REPARATION 2

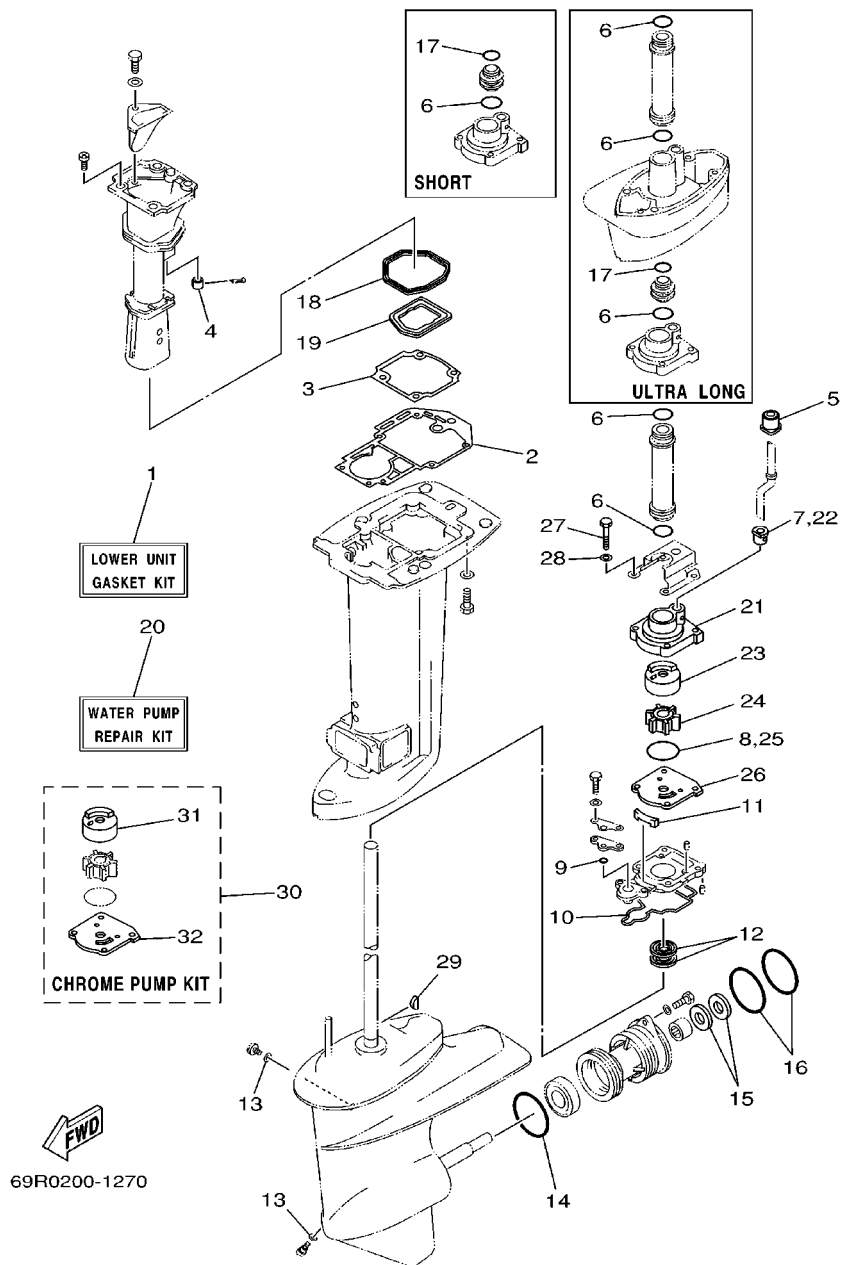

REF. NO.	PART NO. CODIGO NO.	DESCRIPTION DESCRIPTION	MH	WH	W	REMARKS OBSERVACION
1	69P-W0001-20	LOWER UNIT GASKET KIT JUEGO DE EMPAQUE UNIDAD INFER.	1	1	1	
2	689-45113-A1	.GASKET, UPPER CASING .EMPAQUE	1	1	1	
3	69P-41134-A0	.GASKET, EXHAUST MANIFOLD .EMPAQUE	1	1	1	
4	6A8-41135-00	.GASKET, EXHAUST MANIFOLD .EMPAQUE	1	1	1	
5	689-44366-00	.DAMPER, WATER SEAL .GOMA DEL SELLO DE AGUA	1	1	1	
6	93210-26130	.O-RING .ANILLO O	3	3	3	UN
7	6L2-44367-00	.DAMPER, WATER SEAL .GOMA DEL SELLO DE AGUA	1	1	1	
8	93210-45161	.O-RING .ANILLO O	1	1	1	
9	93210-06ME6	.O-RING .ANILLO O	1	1	1	
10	61N-45315-00	.PACKING, LOWER CASING .EMPAQUE	1	1	1	
11	61N-45127-00	.SEAL .SELLO DE GOMA	1	1	1	
12	93101-22067	.OIL SEAL .SELLO ACEITE	2	2	2	
13	90430-08020	.GASKET .JUNTA	2	2	2	
14	93210-64ME7	.O-RING .ANILLO O	1	1	1	
15	93101-20M07	.OIL SEAL .SELLO ACEITE	2	2	2	
16	93210-65M50	.O-RING .ANILLO O	2	2	2	
17	93210-22164	.O-RING .ANILLO O	1	1	1	S,X
18	69P-41138-00	.SEAL, EXT. 1 .SELLO, ESCAPE 1	1	1	1	
19	69P-41139-00	.SEAL, EXT. 2 .SELLO, ESCAPE 2	1	1	1	
20	69P-W0078-00	WATER PUMP REPAIR KIT ESTUCHE REPARACION BOMBA AGUA	1	1	1	
21	69P-44311-00	.HOUSING, WATER PUMP .CAJA BOMBA DE AGUA	1	1	1	
22	6L2-44367-00	.DAMPER, WATER SEAL .GOMA DEL SELLO DE AGUA	1	1	1	
23	69P-44322-00	.INSERT, CARTRIDGE .CARTUCHO	1	1	1	
24	6H4-44352-02	.IMPELLER .IMPULSOR	1	1	1	
25	93210-45161	.O-RING .ANILLO O	1	1	1	
26	61N-44323-00	.OUTER PLATE, CARTRIDGE .PLACA EXTERIOR DEL CARTUCHO	1	1	1	
27	97095-06040	.BOLT .PERNO	4	4	4	

FIG. 27 REPAIR KIT 2

ESTUCHE REPARACION 2

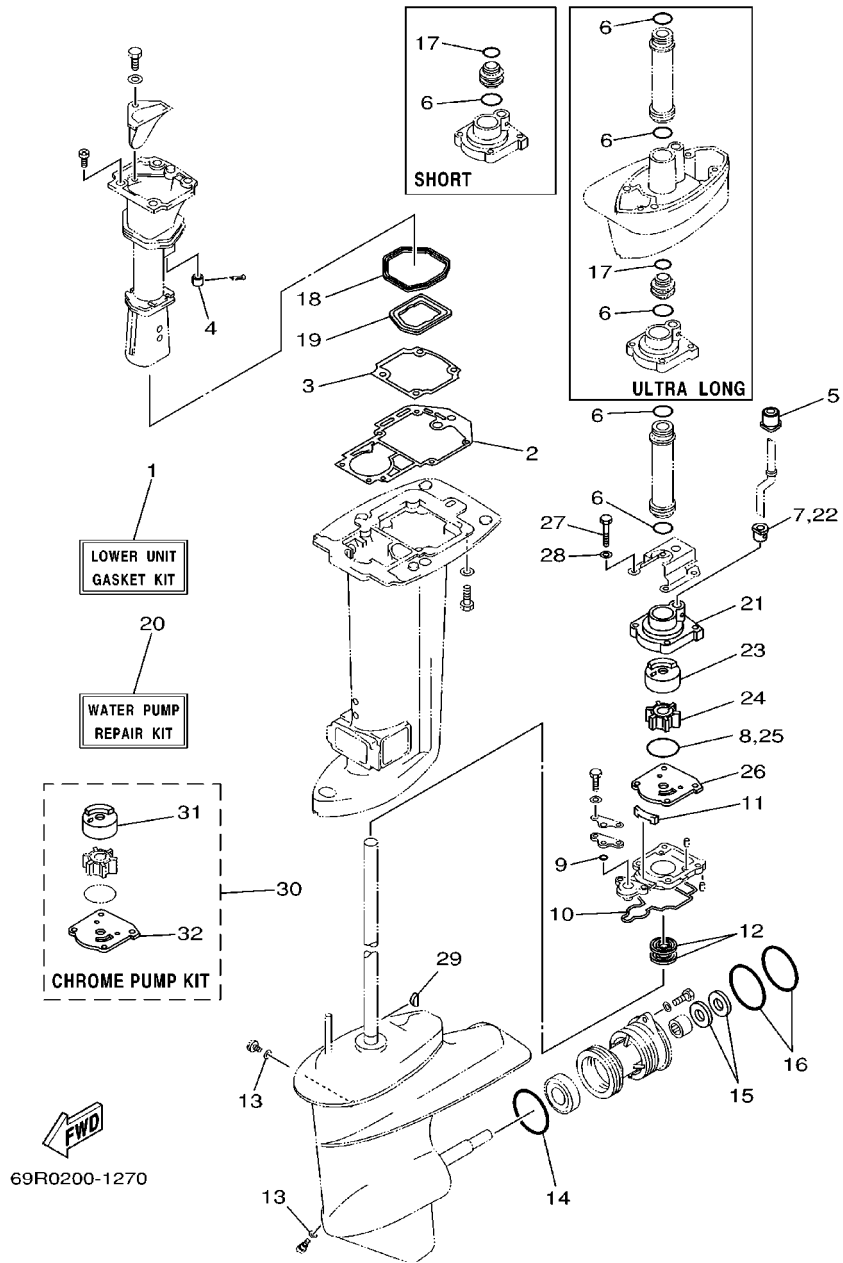

REF. NO.	PART NO. CODIGO NO.	DESCRIPTION DESCRIPTION	MH	WH	W	REMARKS OBSERVACION
28	92995-06600	.WASHER .ARANDELA	4	4	4	
29	90280-03M03	.KEY, WOODRUFF .CUNA WOODRUFF	1	1	1	
30	69P-W0078-0A	CHROME PUMP KIT ESTUCHE REPARACION BOMBA AGUA	1	1	1	
31	69P-44322-40	.INSERT, CARTRIDGE .CARTUCHO	1	1	1	
32	61N-44323-40	.OUTER PLATE, CARTRIDGE .PLACA EXTERIOR DEL CARTUCHO	1	1	1	

NUMERICAL INDEX
INDICE NUMERICO

PART NO. CODIGO NO.	REF. NO.	PART NO. CODIGO NO.	REF. NO.	PART NO. CODIGO NO.	REF. NO.	PART NO. CODIGO NO.	REF. NO.	PART NO. CODIGO NO.	REF. NO.	PART NO. CODIGO NO.	REF. NO.
69P-W0001-00	26 - 1	648-13621-A1	26 - 15	6F5-15713-01	7 - 5	648-24434-01	6 - 19	656-42153-00-94	15 - 15	6E0-43118-01	17 - 3
69P-W0001-20	27 - 1	648-13621-01	4 - 3	6G0-15714-01	7 - 3	648-24435-02	6 - 22	69P-42154-00	15 - 21	663-43118-01	17 - 3
689-W0004-00	4 - 2	61N-13641-01-1S	4 - 4	61N-15715-00	7 - 6	61N-24521-00	6 - 9	69P-42157-00-94	15 - 14	6J8-43131-01	17 - 8
61N-W0070-H0	1 - 11	648-13645-A0	26 - 10	6F5-15716-01	7 - 8	61N-24560-00	6 - 7	69P-42167-00	15 - 19	6E5-43145-01	23 - 9
61R-W0070-10	1 - 11	648-13645-00	4 - 5	6F5-15723-01	7 - 34	61N-24563-00	6 - 8	62Y-42171-00	15 - 22	6G5-43145-01	17 - 9
69P-W0078-0A	27 - 30	6L2-14157-00	5 - 7	6F5-15726-01	7 - 11	61N-24566-01	6 - 12	6F6-42177-A0	14 - 13	689-43160-00	17 - 19
69P-W0078-00	27 - 20	61N-14198-00	4 - 12	61N-15734-00	7 - 7	6YJ-24610-01	22 - 2	69P-42511-00-4D	18 - 4	689-43165-00	17 - 20
69P-W0084-00-4D	14 - 1		26 - 11	6F5-15739-00	7 - 16	61N-26311-00	14 - 24	689-42521-00-94	18 - 7	689-43191-00	17 - 14
69P-W0090-00-1S	2 - 1		26 - 26	6F5-15741-01	7 - 4	61N-26326-00	13 - 18	647-42523-00	13 - 17	689-43192-01	17 - 15
69S-W0090-00-1S	2 - 1	61N-14212-00	5 - 21	69P-15746-00	7 - 41	6K8-41121-00-1S	2 - 31	682-42525-00	10 - 19	689-43311-03-4D	17 - 27
61N-W0093-00	26 - 18	646-14212-01	5 - 18	689-15747-70	7 - 42	6K8-41122-A1	2 - 32		11 - 19	682-43318-01	17 - 44
61N-W1571-11	7 - 1	69P-14301-00	5 - 1	656-15748-00	7 - 37		26 - 8	648-42528-00	18 - 1	689-43373-01	18 - 2
656-W2810-02	6 - 33	69P-14301-10	5 - 1	6G0-15754-00	7 - 9	61N-41123-00-1S	2 - 33	624-42542-00	9 - 7	689-43614-01	17 - 38
61N-11111-01-1S	2 - 19	69S-14301-00	5 - 1	689-15755-01	7 - 14	6K8-41124-A1	2 - 36	69P-42610-H0-4D	1 - 1	648-43615-00	17 - 39
61T-11111-01-1S	2 - 19	69S-14301-10	5 - 1	61N-15758-01-4D	7 - 18		26 - 9	69R-42610-10-4D	1 - 1	689-43616-00	17 - 33
61N-11181-A1	2 - 21	664-14321-01	5 - 13	61N-15762-00	7 - 19	69P-41131-10-5B	19 - 6	69S-42610-10-4D	1 - 1	648-43617-00	17 - 36
	26 - 5	61N-14323-00	5 - 19	6F5-15764-00	7 - 15	69P-41134-A0	19 - 7	69P-42613-00-4D	1 - 7	689-43631-00	17 - 30
61N-11191-01-1S	2 - 22	6A0-14325-00	6 - 26	61T-15770-00	7 - 36		27 - 3	6G0-42615-00	1 - 2	689-43633-00	17 - 31
61N-11193-02	2 - 23	61N-14341-00	5 - 9	6H7-15771-01-94	7 - 29	6A8-41135-00	19 - 14	61N-42628-00	1 - 10	648-43642-00	17 - 34
61T-11193-A1	26 - 6	61T-14341-00	5 - 9	61T-15772-01-94	7 - 31		27 - 4	689-42647-00	1 - 3	689-43643-00	17 - 32
6J8-11325-00	2 - 12	6L2-14342-34	5 - 11	656-15772-00-94	7 - 31	69P-41137-00-5B	19 - 9	6G0-42651-02	1 - 5	689-43681-01	17 - 43
689-11325-00	2 - 17	6L2-14342-36	5 - 11	69P-15774-00	7 - 39	69P-41138-00	19 - 12	61R-42677-10	1 - 12	689-44111-01-4D	15 - 30
6H3-11327-00-94	2 - 13	61N-14343-65	5 - 10	6F5-15779-02	7 - 17		27 - 18	61T-42677-10	1 - 12	664-44113-01	15 - 31
6H3-11328-00	2 - 14	61N-14343-68	5 - 10	6A0-15789-00	7 - 22	69P-41139-00	19 - 13	69P-42677-H0	1 - 12	689-44121-01	15 - 38
676-11372-00	2 - 20	61N-14343-70	5 - 10	6YJ-24167-00	22 - 7		27 - 19	61N-42678-H0	1 - 13	689-44125-00	15 - 39
	2 - 34	50M-14355-00	5 - 12	6YJ-24201-00	22 - 1	69P-41213-00	15 - 18	61R-42678-10	1 - 13	664-44142-00	15 - 33
69P-11400-00	3 - 1		26 - 23	6YJ-24201-10	22 - 1	662-41237-01	15 - 7	61T-42678-10	1 - 13	61N-44143-00	15 - 43
69P-11412-00	3 - 2	61N-14381-00	5 - 2	6YJ-24260-00	22 - 3	682-41237-00	15 - 12	69P-42711-00-4D	13 - 1	61N-44146-00	15 - 47
61N-11422-00	3 - 3	677-14383-01	5 - 15	6Y1-24260-12	22 - 3	682-41238-01	15 - 11	664-42715-00	15 - 26	61N-44150-00	20 - 62
61N-11432-00	3 - 4	6L2-14384-00	5 - 20	6Y1-24268-00	22 - 6	679-41241-01	15 - 9	69P-42716-00	18 - 25	61N-44150-10	20 - 62
61N-11442-00	3 - 5		26 - 13	6G1-24304-02	6 - 1	69P-41241-00	15 - 20	65W-42717-00	13 - 9	61N-44150-30	20 - 62
61N-11515-00	3 - 10		26 - 25	6G1-24305-03	22 - 13	689-41252-01	4 - 20		19 - 2	664-44167-00	15 - 27
61N-11603-00	3 - 19	6L2-14385-00	5 - 5	6Y1-24305-04	22 - 15	61N-41256-00	4 - 21	69P-42717-00	18 - 24	61N-44176-00	20 - 19
61N-11604-00	3 - 19		26 - 21	61J-24306-02	22 - 8	661-41262-02	4 - 22	689-42718-00	18 - 21	6E0-44191-11	1 - 14
61N-11605-00	3 - 19	6E5-14386-01	5 - 4	6A1-24311-00	6 - 31	682-41271-00	4 - 17	61T-42724-40	13 - 15	61N-44194-01	9 - 2
61N-11631-00-95	3 - 18		26 - 20	689-24311-00	6 - 14	689-41273-00	4 - 18	676-42724-40	13 - 18	61T-44194-01	9 - 2
689-11633-00	3 - 20	61N-14392-00	5 - 3	6Y1-24329-00	22 - 5	6J8-41274-00	4 - 19	682-42724-00	13 - 15	69P-44311-00	20 - 10
688-11634-00	3 - 22		26 - 19	61N-24329-00	6 - 2	676-41611-00	8 - 17	689-42724-50	11 - 16		27 - 21
61N-11635-00	3 - 18	6L2-14398-00	5 - 16	650-24351-51	22 - 12	689-41612-01	8 - 21	689-42725-01	13 - 16	69P-44322-00	20 - 12
61N-11636-00	3 - 18		26 - 24	61J-24360-00	22 - 10	676-41613-00	8 - 18	6G0-42796-00	13 - 5		27 - 23
689-11651-00	3 - 12	6L2-14399-00	5 - 8	692-24410-00	6 - 16	61N-41615-00	9 - 1	689-42815-00	13 - 10	69P-44322-40	20 - 12
689-11681-01	3 - 13		26 - 22	663-24411-00	6 - 21	69P-41631-00	15 - 2	689-42816-00	13 - 13		27 - 31
6E5-12411-01	2 - 26	61N-14440-00	4 - 13	692-24411-00	6 - 18	689-42111-01-4D	14 - 2	689-43111-03-4D	17 - 1	61N-44323-00	20 - 15
655-12413-01-1S	2 - 28	69P-14497-00	15 - 1	6A0-24412-02	6 - 27	69P-42112-00-4D	14 - 7	689-43112-02-4D	17 - 2		27 - 26
655-12414-A1	26 - 7	62Y-14597-00	5 - 23	6A0-24413-00	6 - 17	664-42119-00	14 - 12	6J8-43113-01	17 - 13	61N-44323-40	20 - 15
655-12414-00	2 - 29	69P-15100-00-1S	2 - 2	6A0-24421-01	6 - 25	656-42126-01	14 - 21	6F5-43114-00	17 - 6		27 - 32
61N-13610-00	4 - 1	689-15396-01-5B	2 - 6	650-24431-A0	6 - 28	6G1-42137-10	14 - 15	648-43114-01	17 - 6	65W-44328-10	20 - 18
689-13610-01	4 - 1	61N-15711-10	7 - 2		26 - 17	689-42138-00	14 - 20	6G0-43116-00	17 - 5	6H4-44352-02	20 - 13

NUMERICAL INDEX
INDICE NUMERICO

PART NO. CODIGO NO.	REF. NO.	PART NO. CODIGO NO.	REF. NO.	PART NO. CODIGO NO.	REF. NO.	PART NO. CODIGO NO.	REF. NO.	PART NO. CODIGO NO.	REF. NO.	PART NO. CODIGO NO.	REF. NO.
6H4-44352-00	27 - 24	61N-45321-00	20 - 20	703-48189-00	25 - 17	689-48511-01	16 - 1	703-82531-00	25 - 45	90116-10M33	19 - 22
61N-44361-00	21 - 1	61N-45331-00-5B	20 - 24	703-48198-00	25 - 14	689-48531-50	16 - 11	689-82540-01	10 - 14	90119-06MA0	2 - 39
61N-44361-10	21 - 1	688-45341-00	20 - 34	703-48211-01	25 - 60	689-48532-50	16 - 8	703-82540-00	25 - 49	90119-06MA2	2 - 24
61N-44361-30	21 - 1	61N-45361-01-4D	20 - 52	703-48212-00	25 - 57	648-48534-50-4D	16 - 5	682-82556-00	13 - 20		2 - 30
61N-44362-00	20 - 7	61N-45371-00	21 - 6	703-48213-00	25 - 58	689-61350-02	23 - 1		25 - 47	90119-06MA3	2 - 37
61N-44362-10	20 - 7	61N-45375-00	19 - 21	703-48215-00	25 - 42	689-61351-01	23 - 2	61T-82560-00	11 - 30		7 - 30
	20 - 60	61N-45510-00	20 - 36	703-48219-00	25 - 29	6E5-61355-00	23 - 5	689-8257Y-00	13 - 21		7 - 32
689-44366-00	21 - 2	61N-45510-10	20 - 36	703-48221-00	25 - 55	61N-81313-09	8 - 4	6E9-82575-02	13 - 19	90119-06MA4	2 - 38
	27 - 5	61N-45510-30	20 - 36	703-48222-00	25 - 26	689-81328-70	8 - 7	688-82575-01	25 - 46		7 - 32
6L2-44367-00	20 - 11	61N-45536-00	20 - 5	703-48223-00	25 - 27	689-81800-13	12 - 1	676-82577-00	25 - 44	90119-06M17	15 - 25
	27 - 7	61N-45551-00	20 - 38	703-48224-00	25 - 54	689-81807-12	12 - 3	61T-82580-00	11 - 13	90119-06M23	7 - 43
	27 - 22	61N-45560-00	20 - 42	703-48225-00	25 - 28	689-81809-11	12 - 7	688-82586-21	25 - 48	90119-06M48	21 - 7
664-44514-00-94	18 - 35	6L2-45567-00-10	20 - 41	703-48226-00	25 - 25	689-81810-11	12 - 9	61T-82588-00	11 - 31	90119-06M73	13 - 14
689-44516-00	18 - 30	6L2-45567-00-11	20 - 41	703-48227-00	25 - 24	689-81811-11	12 - 12	61T-82590-00	11 - 14	90119-06M94	4 - 15
69P-44518-00-94	18 - 14	6L2-45567-00-12	20 - 41	703-48228-00	24 - 1	689-81812-11	12 - 11	703-82591-00	25 - 52	90119-06M95	9 - 8
648-44519-00-94	18 - 16	6L2-45567-00-13	20 - 41		25 - 1	689-81813-10	12 - 13	703-82592-00	25 - 53	90119-06024	19 - 19
689-44551-01-4D	18 - 43	6L2-45567-00-14	20 - 41	703-48232-00	25 - 61	689-81820-11	12 - 14	689-82594-00	10 - 18	90119-06025	7 - 33
689-44552-01-4D	18 - 45	61N-45571-00	20 - 50	703-48234-00	25 - 18	689-81826-10	12 - 15	689-82594-10	11 - 18	90119-08M03	18 - 47
689-44553-00-94	18 - 39	6L2-45577-00-10	20 - 51	703-48235-00	25 - 4	689-81830-11	12 - 4	703-83383-02	25 - 50	90119-08M65	2 - 4
689-44555-00	18 - 44	6L2-45577-00-11	20 - 51	703-48236-00	25 - 16	689-81831-00	12 - 5	6E9-85516-70	8 - 9	90119-08009	2 - 3
689-44557-00	18 - 40	6L2-45577-00-12	20 - 51	703-48238-00	25 - 22	689-81840-11	12 - 10	663-85518-00	15 - 10	90119-08015	2 - 25
648-44591-00	18 - 29	6L2-45577-00-13	20 - 51	703-48243-00	25 - 15	689-81847-11	12 - 6	61N-85537-00	8 - 13	90149-05M13	14 - 14
	18 - 34	61N-45587-00-07	20 - 4	703-48244-00	25 - 21	689-81850-12	12 - 8	61N-85540-11	9 - 13	90149-14030	17 - 5
664-44591-00	18 - 36	61N-45587-00-10	20 - 4	703-48245-00	25 - 11	689-81857-11	12 - 2	69P-85541-09	8 - 3	90151-05M05	21 - 10
69P-45111-00-4D	19 - 1	61N-45587-00-11	20 - 4	703-48246-00	25 - 23	689-81870-00	10 - 16	61N-85542-00-94	9 - 5	90151-06M02	2 - 18
69P-45111-10-4D	19 - 1	61N-45587-00-12	20 - 4	701-48248-00	25 - 13	6H3-81922-00	9 - 18	61N-85543-09	8 - 5	90161-06M00	10 - 20
689-45113-A1	2 - 41	61N-45587-00-13	20 - 4	703-48252-00	25 - 12	6G1-81941-10	10 - 3	61N-85543-19	8 - 6		11 - 20
	26 - 14	61N-45587-00-14	20 - 4	703-48261-11	25 - 2		11 - 2	61N-85550-10	8 - 1	90170-09M03	23 - 8
	27 - 2	61N-45587-00-15	20 - 4	703-48264-00	25 - 6	61T-81945-01	10 - 5	61T-85550-10	8 - 1	90170-10M42	18 - 27
663-45119-00	17 - 18	61N-45587-00-16	20 - 4	703-48265-00	25 - 9		11 - 4	69P-85560-00	8 - 2		18 - 33
	17 - 29	6L2-45611-00	20 - 43	703-48268-00	25 - 5	6G1-81952-00	10 - 4	69P-85561-00	8 - 10	90171-14013	21 - 15
	18 - 23	664-45631-02	20 - 45	703-48271-00	25 - 59		11 - 3	6H5-85570-00	9 - 20	90176-10M01	18 - 38
61N-45127-00	20 - 26	648-45633-00	20 - 47	703-48281-00	25 - 30	664-81970-61	10 - 7	61N-85570-00	9 - 20	90179-06M24	1 - 8
	27 - 11	648-45635-00	20 - 44	703-48282-00	25 - 31		11 - 6		9 - 25	90179-10M03	19 - 26
69P-45127-00	19 - 17	62C-45941-00-EL	21 - 17	703-48284-00	25 - 51	689-81971-00	10 - 2	61N-85570-10	9 - 25	90179-10M14	20 - 39
69P-45128-00	19 - 18	664-45941-01-EL	21 - 17	701-48287-00	25 - 41	689-82105-13	10 - 17	61T-86111-00	11 - 21	90179-16M05	8 - 15
69P-45159-00	19 - 20	664-45943-01-EL	21 - 17	703-48291-10	25 - 38		11 - 15	61T-86112-00	11 - 24	90185-05002	21 - 11
61N-45211-31-4D	19 - 23	664-45945-00-EL	21 - 17	703-48293-10	25 - 40	682-82150-10	10 - 12	682-86116-00	11 - 22	90185-06062	14 - 23
6L2-45214-00	21 - 8	664-45947-01-EL	21 - 17	701-48320-20	24 - 2		11 - 11	682-86117-00	11 - 23	90185-09M01	23 - 4
6L2-45215-00	21 - 9	664-45949-02-EL	21 - 17	701-48320-50	24 - 2	682-82151-00	10 - 13	90101-08339	17 - 23	90185-10051	16 - 4
61N-45251-00	20 - 31	664-45952-00-EL	21 - 17	648-48330-50	16 - 20		11 - 12	90105-06M07	15 - 32	90185-22043	17 - 10
69P-45300-00-4D	20 - 1	664-45954-01-EL	21 - 17	617-48331-91	16 - 21	61N-82317-00	9 - 6		18 - 6	90201-06M30	9 - 9
69P-45300-10-4D	20 - 1	6L2-45987-01	21 - 12	648-48340-50	16 - 14	6G1-82370-21	9 - 29	90105-06M08	18 - 26	90201-06416	15 - 5
69P-45300-30-4D	20 - 1	689-45997-00	21 - 13	703-48345-01	25 - 19	663-82370-01	9 - 29	90105-06M18	18 - 3	90201-08M87	13 - 4
61N-45311-02-4D	20 - 2	69P-47467-00-5B	19 - 16	617-48346-90	16 - 16	703-82510-31	25 - 43	90105-08M10	7 - 35	90201-10M20	23 - 3
61N-45315-00	20 - 27	69P-47467-10-5B	19 - 16	648-48346-50	16 - 22	61N-82519-01	9 - 10	90105-10M12	21 - 4	90201-10M63	23 - 6
	27 - 10	703-48152-00	25 - 56	703-48358-00	25 - 20	689-82531-02	10 - 6	90109-06M12	17 - 7	90201-16M44	8 - 16
689-45318-00	19 - 24	703-48153-00	25 - 3	617-48361-91	16 - 15		11 - 5	90109-06M18	17 - 45	90201-20M27	3 - 23

NUMERICAL INDEX
INDICE NUMERICO

PART NO. CODIGO NO.	REF. NO.	PART NO. CODIGO NO.	REF. NO.	PART NO. CODIGO NO.	REF. NO.	PART NO. CODIGO NO.	REF. NO.	PART NO. CODIGO NO.	REF. NO.	PART NO. CODIGO NO.	REF. NO.
90201-20417	20 - 49	90445-10M41	2 - 35	92903-06600	4 - 7	92995-08600	18 - 42	93332-00005	20 - 40	97090-06012	9 - 23
90201-21567	2 - 27	90445-11M05	22 - 11		4 - 9		18 - 49	93390-00009	3 - 17		10 - 10
90201-22M03	17 - 11	90445-11M06	22 - 9		4 - 11		19 - 5	93399-99951	3 - 6		11 - 9
90201-28013	14 - 5	90446-10M02	10 - 15	92903-08600	12 - 17		19 - 11	93430-06024	25 - 10	97095-06010	7 - 40
90201-50306	2 - 40	90465-06M88	4 - 24		12 - 19	92995-10600	19 - 27		25 - 62		9 - 3
90202-06007	15 - 35	90465-13M11	9 - 19	92903-10600	14 - 17		21 - 5	93440-62057	3 - 11	97095-06012	15 - 6
	15 - 44	90465-18147	11 - 29	92990-05100	6 - 24	93101-16001	2 - 8	93602-20M02	3 - 21		16 - 6
90202-10024	15 - 41	90467-08004	6 - 6	92990-05600	8 - 20		26 - 3	93604-10M03	20 - 25	97095-06016	7 - 20
90206-05005	7 - 45		6 - 15		10 - 9	93101-20M07	20 - 56	93606-11M24	19 - 25		16 - 9
90206-12052	13 - 11		6 - 32		11 - 8		27 - 15		21 - 3		16 - 12
90206-28001	14 - 6	90480-10155	11 - 25		15 - 37	93101-22067	20 - 28	93606-12019	2 - 5	97095-06018	18 - 18
90209-24M03	3 - 15	90480-14M14	1 - 9		15 - 45		27 - 12		18 - 17	97095-06020	6 - 3
90209-47016	18 - 9	90480-15M06	13 - 2	92990-06100	9 - 12	93102-25008	2 - 7		19 - 3		9 - 14
90240-05047	17 - 40	90480-17M08	10 - 1		9 - 17		26 - 2	93608-12063	18 - 8		9 - 21
90243-04M01	17 - 4		11 - 1		9 - 24	93102-32M07	3 - 7	93700-06M03	17 - 17		9 - 27
90243-04007	17 - 4		13 - 22		10 - 11	93210-03261	11 - 28		17 - 28		14 - 10
90249-06M22	17 - 35	90480-17165	11 - 17		11 - 10	93210-06ME6	20 - 21		18 - 22		14 - 22
90250-05010	20 - 46	90480-25161	9 - 26	92990-06300	20 - 33		27 - 9	94702-00160	2 - 42		18 - 31
90266-04M00	1 - 6	90480-29045	18 - 5	92990-08600	16 - 19	93210-08287	22 - 14	94702-00217	2 - 42	97095-06022	2 - 10
90266-04M01	1 - 4	90501-09M08	15 - 29		16 - 25		22 - 16	94702-00247	2 - 42	97095-06025	20 - 22
90269-02M09	14 - 16	90501-10065	20 - 48		25 - 33	93210-16275	23 - 10	94702-00271	2 - 42	97095-06035	7 - 23
90280-03M03	20 - 37	90501-10071	16 - 24	92990-10200	18 - 28	93210-22164	20 - 8	95303-08700	7 - 12		7 - 26
	27 - 29	90501-10227	7 - 38		18 - 37		27 - 17	95380-03600	6 - 20	97095-06040	6 - 29
90280-05015	8 - 14	90501-10264	16 - 18	92990-10600	16 - 3	93210-26130	20 - 9	95380-05600	15 - 13		20 - 16
90340-08M04	20 - 29	90501-14M07	15 - 28	92990-14200	21 - 14		20 - 61		25 - 7		27 - 27
90381-12M01	18 - 20	90501-23215	14 - 18	92995-06600	2 - 11		27 - 6	95380-05700	15 - 8	97095-06045	15 - 4
90386-08032	14 - 19	90502-10M07	17 - 22		6 - 4	93210-32738	6 - 10	95380-06600	7 - 28	97095-06050	14 - 8
90386-10009	15 - 16	90506-16M17	17 - 46		6 - 30		26 - 16		15 - 48	97095-08020	19 - 10
90386-12069	13 - 12	90506-30M27	17 - 42		7 - 21	93210-37160	18 - 12		25 - 39	97095-08030	25 - 32
90386-22M67	17 - 12	90508-14M13	15 - 40		7 - 24	93210-40659	4 - 14	95380-08600	6 - 11	97095-08065	18 - 48
90386-38022	18 - 13	91490-12010	15 - 36		7 - 27		26 - 12		17 - 26	97313-08030	7 - 10
90386-38090	18 - 11	91490-16010	7 - 47		9 - 4		26 - 27		18 - 46	97380-05025	25 - 8
90386-47M22	18 - 10		15 - 23		9 - 15	93210-45161	20 - 14	95380-08700	13 - 6	97607-04112	8 - 11
90387-06M26	4 - 16		15 - 34		9 - 22		27 - 8		13 - 8	97607-06125	8 - 12
90387-06M59	15 - 3		17 - 41		9 - 28		27 - 25	95895-06035	20 - 32	97802-04006	8 - 8
90387-06M60	15 - 24	91490-20010	15 - 46		14 - 9	93210-46M16	3 - 8	97013-06014	6 - 13	97880-05012	8 - 19
90387-06013	7 - 44	91490-30022	21 - 16		14 - 11	93210-58M21	2 - 9	97013-06016	2 - 15		11 - 27
90387-08M03	17 - 24	91490-30025	19 - 15		16 - 7		26 - 4	97013-06025	4 - 6	97880-05025	10 - 8
90387-08M25	13 - 3	91690-30008	17 - 21		16 - 10	93210-64ME7	20 - 54	97013-06035	4 - 8		11 - 7
90387-10M39	18 - 15	91690-30012	16 - 17		16 - 13		27 - 14	97013-06050	4 - 10	97880-06010	8 - 22
90387-10M42	23 - 7		16 - 23		18 - 19	93210-65M50	20 - 57	97013-08012	12 - 18	97880-06016	19 - 8
90387-13003	14 - 3	91690-30016	17 - 16		18 - 32		27 - 16	97013-08030	12 - 16	97890-05006	5 - 22
90387-32002	3 - 16	91690-40016	15 - 42		20 - 17	93306-00612	20 - 53	97075-06020	20 - 58	97980-04110	5 - 6
90387-33001	14 - 4	91690-40018	15 - 17		20 - 23	93306-305U3	3 - 9	97075-08025	18 - 41	97980-04112	5 - 14
90430-08020	20 - 30	91690-40035	17 - 47		20 - 59	93310-62406	3 - 14	97075-08030	19 - 4	98503-04006	11 - 26
	20 - 35	91690-40048	4 - 23		27 - 28	93315-220V7	20 - 6	97075-10040	16 - 2	98503-05028	6 - 23
	27 - 13	92903-05600	7 - 46	92995-08600	13 - 7	93315-22004	20 - 55	97090-06012	9 - 11	98580-03015	25 - 37
90445-09M75	6 - 5	92903-06600	2 - 16		17 - 25	93332-000W5	20 - 3		9 - 16	98580-04006	25 - 35

NUMERICAL INDEX
INDICE NUMERICO

<u>PART NO.</u> <u>CODIGO NO.</u>	<u>REF.</u> <u>NO.</u>	<u>PART NO.</u> <u>CODIGO NO.</u>	<u>REF.</u> <u>NO.</u>	<u>PART NO.</u> <u>CODIGO NO.</u>	<u>REF.</u> <u>NO.</u>	<u>PART NO.</u> <u>CODIGO NO.</u>	<u>REF.</u> <u>NO.</u>	<u>PART NO.</u> <u>CODIGO NO.</u>	<u>REF.</u> <u>NO.</u>
98580-04010	25 - 34								
98580-05010	25 - 36								
98586-05016	22 - 4								
98980-04006	5 - 17								
99009-17500	11 - 32								
99080-05600	17 - 37								
99530-10014	7 - 25								