

**PARTS
CATALOGUE
CATALOGUE
DE PIÈCES DÉTACHÉES**

25DMH'01 (6950)

YAMAHA
GENUINE
Parts & Accessories

2Z695-300F1

A1

FOREWORD

This Parts Catalogue is related to the parts for the model(s) in the below frame. When you are ordering replacement parts, please refer to this Parts Catalogue and quote both part numbers and part names correctly.

25DMH*01(6950)

1. Modifications or additions which have been made after issue of the Parts Catalogue will be announced in the Yamaha Parts News.
It is advisable that you make necessary corrections to the Parts Catalogue according to the Yamaha Parts News.

2. Abbreviations
The Following abbreviations are used in this Parts Catalogue.

- "UR" Use specified parts number.
- "UN" Use as many as needed.
- "AP" Alternate Parts
- "LM" Local Made
(Parts need to be ordered locally)
- "O/S" Over Size

3. Parts, which are to be supplied in an assembly, are listed with a dot(.) in front of the part name as shown below.

EXAMPLE
CARBURETOR ASSY
.JET, PILOT
.NOZZLE, MAIN

4. Number of component for assembly
The numeral appearing to the right of each component part indicates the quantity of parts for each assembly unit.

EXAMPLE

PART NO.	DESCRIPTION	U	H	L	T	R	REMARKS
6E0-85500-70	C.D.I. MAGNETO ASSY	1					
6E0-85550-70	.ROTOR ASSY	1					
6E0-15723-00-94	.PULLY, STARTER	1					

5. Quantity Column Information

NAME for Q'TY COLUMN	APPLICABLE MODEL
25D	25DMH

6. Applicable Starting Serial No. and Color Code
1) Engine Starting Serial No.

25DMH	S : 042315 L : 332931
-------	--------------------------

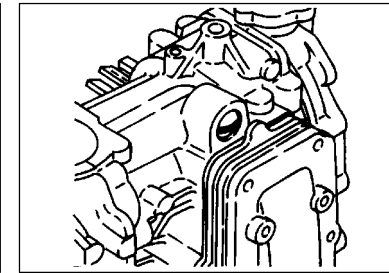
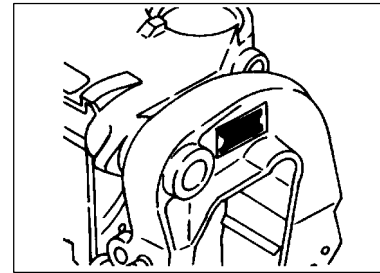

2) Color Code

Color Code	Color Name	Abbreviation
004D	DARK BLUISH GRAY METALLIC 2	DBNM2

7. Note that the illustrations for reference in finding parts numbers, not to be used for assembling. When assembling, please use the applicable service manual.

8. The asterisk (*) before a reference number indicates modification items after the first edition.

CONTENTS

TOP COWLING	A4
CYLINDER. CRANKCASE	A5
CRANKSHAFT. PISTON	A7
INTAKE	B2
FUEL	B4
STARTER	B6
GENERATOR	C1
ELECTRICAL	C2
BOTTOM COWLING	C3
STEERING	C4
CONTROL	C5
BRACKET 1	C7
BRACKET 2	D2
UPPER CASING	D4
LOWER CASING. DRIVE 1	D5
LOWER CASING. DRIVE 2	E1
FUEL TANK	E3
REPAIR KIT 1	E4
REPAIR KIT 2	E6
INDEX	
NUMERICAL INDEX	E7

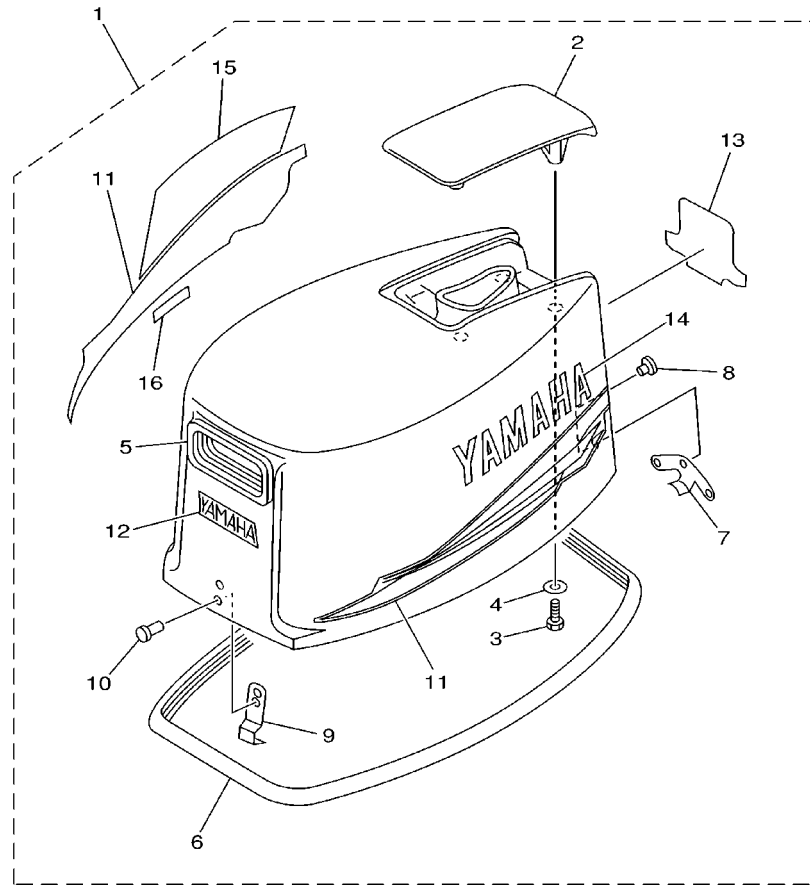

FIG. 1 TOP COWLING

CAPOT SUPERIEUR

REF. NO.	PART NO. NO. PIECES	DESCRIPTION DESCRIPTION	25D				REMARKS REMARQUES
1	695-42610-B2-4D	TOP COWLING ASSY CAPOT (ENS.)	1				
2	689-42613-01-4D	.MOLDING, AIR DUCT .MANCHON A AIR	1				
3	97095-06012	.BOLT .BOULON	4				
4	92995-06600	.WASHER .RONDELLE	4				
5	689-15761-00	.SEAL, RUBBER 1 .JOINT CAOUTCHOUC 1	1				
6	6G0-42615-00	.SEAL .JOINT	1				
7	689-42647-00	.HOLDER, CLAMP BAND .SUPPORT, SANDOW DE SERRAGE	1				
8	90266-04M01	.RIVET .RIVET	3				
9	6G0-42651-02	.HOOK .CROCHET	1				
10	90266-04M00	.RIVET .RIVET	2				
11	695-W0070-12	.GRAPHIC SET .JEU DIEMBLEMES	1				
12	695-42677-B1	.GRAPHIC, FRONT .ADHESIF, AVANT	1				
13	695-42678-12	.GRAPHIC, REAR .ADHESIF, ARRIERE	1				
14	695-42681-11	.MARK, COWLING .ADHESIF, CAPOT	1				
15	695-42682-12	.MARK, COWLING .ADHESIF, CAPOT	1				
16	6E0-44191-11	.INDICATOR, SHIFT .ETIQUETTE, EMBRAYAGE	1				



6950300-1010

FIG. 2 CYLINDER, CRANKCASE CYLINDRE, CARTER

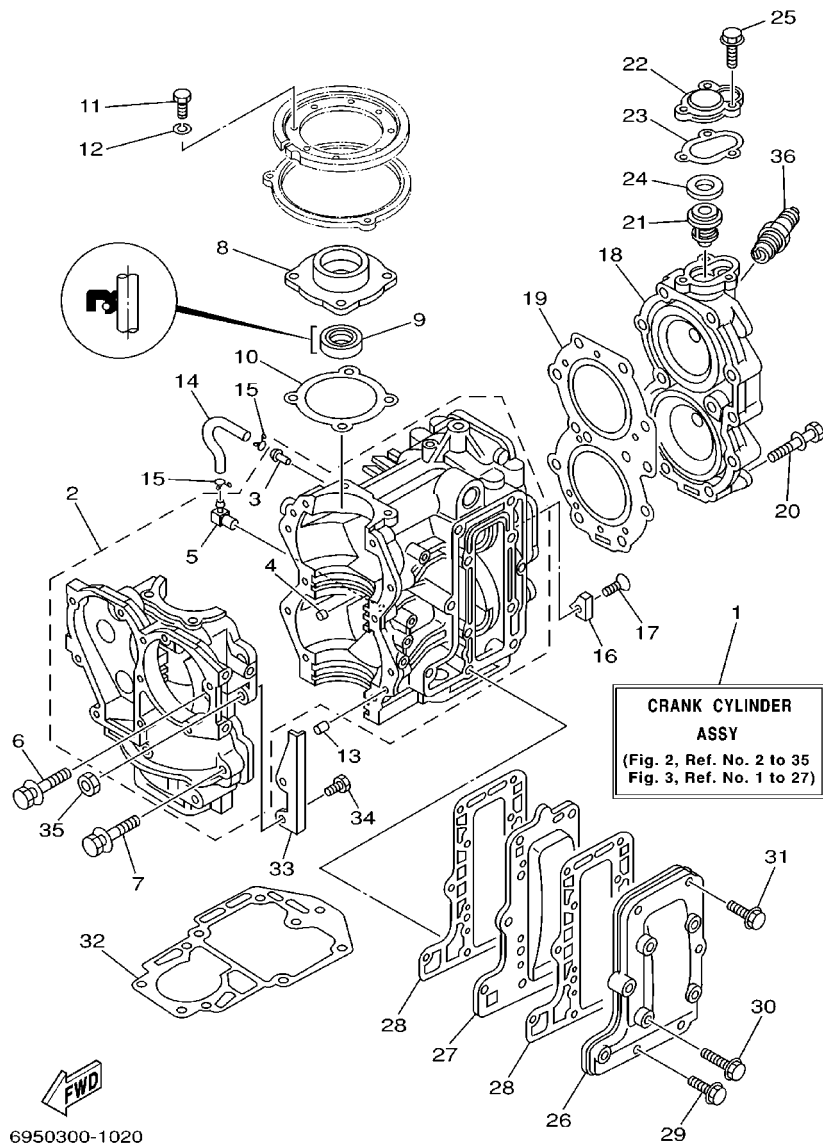

6950300-1020

REF. NO.	PART NO. NO. PIECES	DESCRIPTION DESCRIPTION	25D				REMARKS REMARQUES
1	695-W0090-84-4D	CRANK CYLINDER ASSY EMBIELLAGE CYLINDRE (ENS.)	1				
2	695-15100-02-94	CRANKCASE ASSY CARTER DE MOTEUR COMPLET	1				
3	624-14485-00	.PIPE, JOINT .DURITE	1				
4	624-11379-00	.VALVE, CHECK .CLAPET	1				
5	650-11370-00	.CHECK VALVE ASSY .CLAPET (ENS.)	1				
6	90119-08009	BOLT, WITH WASHER BOULON, AVEC RONDELLE	2				
7	90119-08M66	BOLT, WITH WASHER BOULON, AVEC RONDELLE	8				
8	664-15359-01-94	HOUSING, OIL SEAL LOGEMENT, BAGUE D'ETANCHEITE	1				
9	93102-23096	OIL SEAL JOINT SPY	1				
10	664-15369-A0	GASKET, OIL SEAL HOUSING JOINT SPY DE LOGEMENT	1				
11	97013-06020	BOLT BOULON	4				
12	92903-06100	WASHER, SPRING RONDELLE, GROUVER	4				
13	93606-12019	PIN, DOWEL GOIJON	2				
14	90445-07260	HOSE (L276) DURITE (L276)	1				
15	90467-06016	CLIP JONC	2				
16	689-11325-00	ANODE ANODE	1				
17	90151-06M02	SCREW, COUNTERSUNK VIS, TETE NOYEE	1				
18	695-11111-01-94	HEAD, CYLINDER 1 CULASSE	1				
19	695-11181-A1	GASKET, CYLINDER HEAD 1 JOINT, DE CULASSE 1	1				
20	90119-08016	BOLT, WITH WASHER BOULON, AVEC RONDELLE	11				
21	6F5-12411-02	THERMOSTAT THERMOSTAT	1				
22	655-12413-01-9M	COVER, THERMOSTAT COUVERCLE, THERMOSTAT	1				
23	655-12414-A1	GASKET, COVER JOINT, COUVERCLE	1				
24	90201-21567	WASHER, PLATE RONDELLE, PLATE	1				
25	90119-06MA2	BOLT, WITH WASHER BOULON, AVEC RONDELLE	3				
26	664-41113-00-94	OUTER COVER, EXHAUST COUVERCLE, ECHAPPEMENT	1				
27	664-41111-00	INNER COVER, EXHAUST PLAQUE, ECHAPPEMENT	1				

FIG. 3 CRANKSHAFT. PISTON

VILEBREQUIN. PISTON

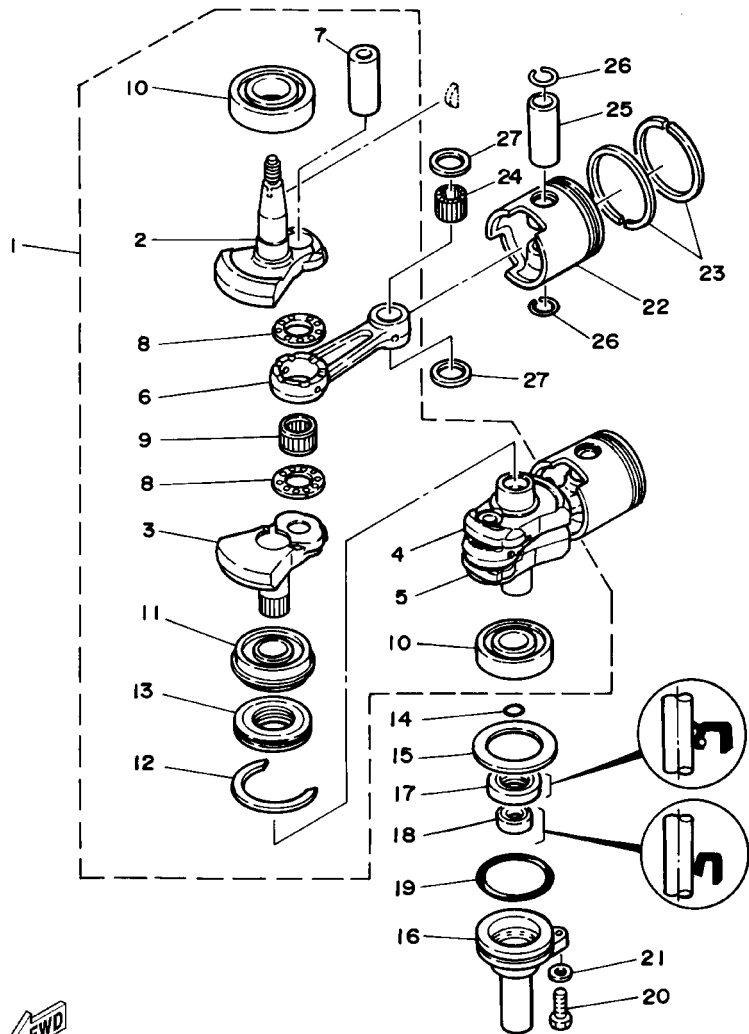



6950300-4030

REF. NO.	PART NO. NO. PIECES	DESCRIPTION DESCRIPTION	25D				REMARKS REMARQUES
1	695-11400-00	CRANKSHAFT ASSY VILEBREQUIN COMPLET	1				
2	695-11412-00	.CRANK 1 .MASSOLOTTE DE VILEBREQUIN 1	1				
3	6G0-11422-00	.CRANK 2 .MASSOLOTTE DE VILEBREQUIN 2	1				
4	6G0-11432-00	.CRANK 3 .MASSOLOTTE DE VILEBREQUIN 3	1				
5	695-11442-00	.CRANK 4 .MASSOLOTTE DE VILEBREQUIN 4	1				
6	648-11651-04	.ROD, CONNECTING .BIELLE NUE	2				
7	648-11681-00	.PIN, CRANK 1 .MANETON, VILEBREQUIN 1	2				
8	90209-22071	.WASHER .RONDELLE	4				
9	93310-522W0	.BEARING .ROULEMENT	2				
10	93306-305U3	.BEARING .ROULEMENT	2				
11	93390-00009	.BEARING .ROULEMENT	1				
12	93440-62057	.CIRCLIP .CIRCLIP, TYPE S	1				
13	656-11515-00	.SEAL, LABYRINTH 1 .JOINT, LABYRINTHE 1	1				
14	93210-16275	O-RING .JOINT TORIQUE	1				
15	90201-50306	WASHER, PLATE .RONDELLE, PLATE	1				
16	689-15396-01-5B	HOUSING, OIL SEAL .LOGEMENT DE JOINT SPY	1				
17	93101-25M35	OIL SEAL .JOINT SPY	1				
18	93101-16M36	OIL SEAL .JOINT SPY	1				
19	93210-58M21	O-RING .JOINT TORIQUE	1				
20	97095-06022	BOLT .BOULON	1				
21	92995-06600	WASHER .RONDELLE	1				
22	664-11631-80-96	PISTON (STD) .PISTON (STD)	2				
	664-11635-80	PISTON (0.25MM O/S) .PISTON (0.25MM O/S)	2				AP
	664-11636-80	PISTON (0.50MM O/S) .PISTON (0.50MM O/S)	2				AP
23	664-11610-80	PISTON RING SET (STD) .JEU DE SEGMENTS (STD)	2				
	664-11610-40	PISTON RING SET (0.25MM O/S) .JEU DE SEGMENTS (0.25MM O/S)	2				AP
	664-11610-50	PISTON RING SET (0.50MM O/S) .JEU DE SEGMENTS (0.50MM O/S)	2				AP

FIG. 4 INTAKE

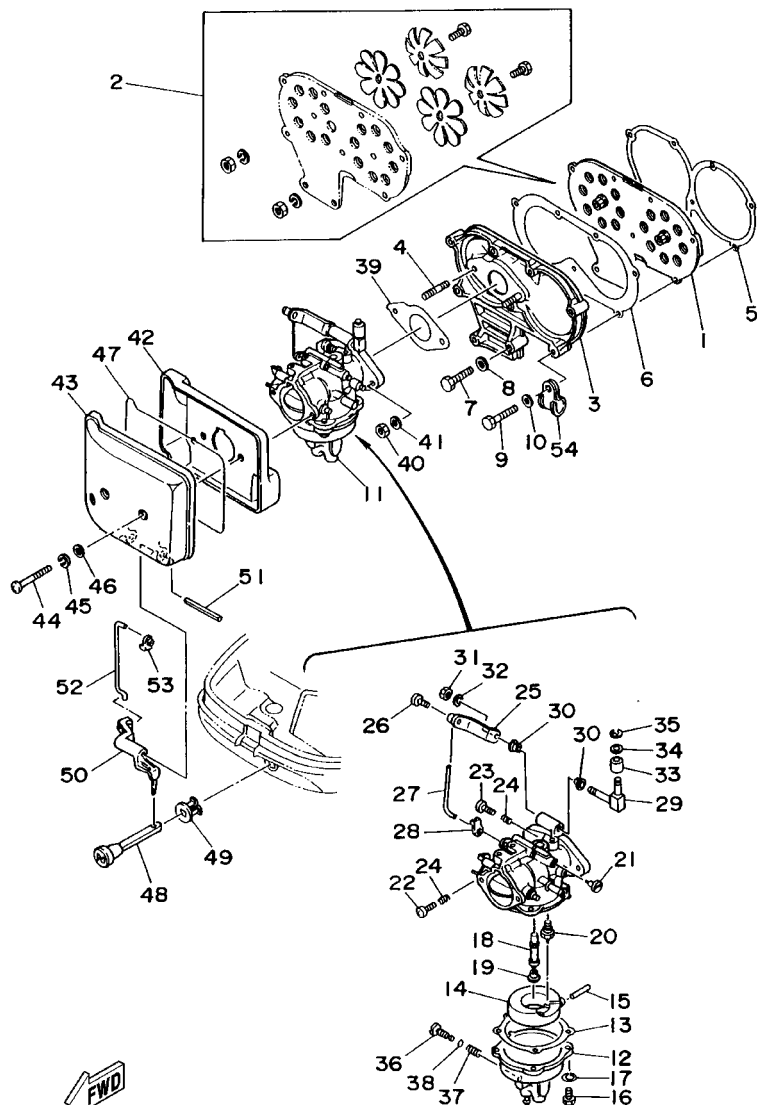
ADMISSION



6950300-7040

REF. NO.	PART NO. NO. PIECES	DESCRIPTION DESCRIPTION	25D				REMARKS REMARQUES
1	689-13610-01	REED VALVE ASSY CLAPET COMPLET	1				
2	689-W0004-00	.REED SET .JEU DE CLAPETS	1				
3	648-13641-01-94	MANIFOLD 1 TUBULURE 1	1				
4	90116-06M30	BOLT, STUD GOUJON	2				
5	648-13621-A1	GASKET, VALVE SEAT JOINT, SIEGE DE CLAPET	1				
6	648-13645-A0	GASKET, MANIFOLD 1 JOINT, TUBULURE 1	1				
7	97013-06025	BOLT BOULON	2				
8	92903-06600	WASHER, PLATE RONDELLE, PLATE	2				
9	97013-06035	BOLT BOULON	7				
10	92903-06600	WASHER, PLATE RONDELLE, PLATE	7				
11	695-14301-02	CARBURETOR ASSY 1 CARBURATEUR COMPLET	1				
12	664-14381-01	.BODY, FLOAT CHAMBER .CORPS, CUVE DE FLOTTEUR	1				
13	648-14384-01	.GASKET, FLOAT CHAMBER JOINT, CUVE DE FLOTTEUR	1				
14	648-14385-00	.FLOAT .FLOTTEUR	1				
15	648-14386-00	.PIN, FLOAT .AXE, FLOTTEUR	1				
16	98580-04012	.SCREW, PAN HEAD .VIS, TETE TRONCONIQUE	4				
17	92990-04100	.WASHER, SPRING .RONDELLE, GROUER	4				
18	648-14341-00	.NOZZLE, MAIN .PUITS D'AIGUILLE	1				
19	689-14343-73	.JET, MAIN (#146) .GICLEUR, PRINCIPAL (#146)	1				
20	61K-14390-00	.NEEDLE VALVE ASSY POINTEAU	1				
21	648-14342-30	.JET, PILOT (#60) .GICLEUR, RALENTI (#60)	1				
22	98580-04014	.SCREW, PAN HEAD .VIS, TETE TRONCONIQUE	1				
23	647-14323-00	.SCREW, AIR ADJUSTING .VIS DE DOSEUR D'AIR	1				
24	648-14334-00	.SPRING, AIR ADJUSTING .RESSORT, VIS DE DOSEUR D'AIR	2				
25	648-41210-01	.ACCEL. ARM ASSY .LEVIER D'ACCELERATION	1				
26	664-14327-01	.SCREW .VIS	1				
27	656-41241-00	.ROD, LINK .BIELLETTE	1				

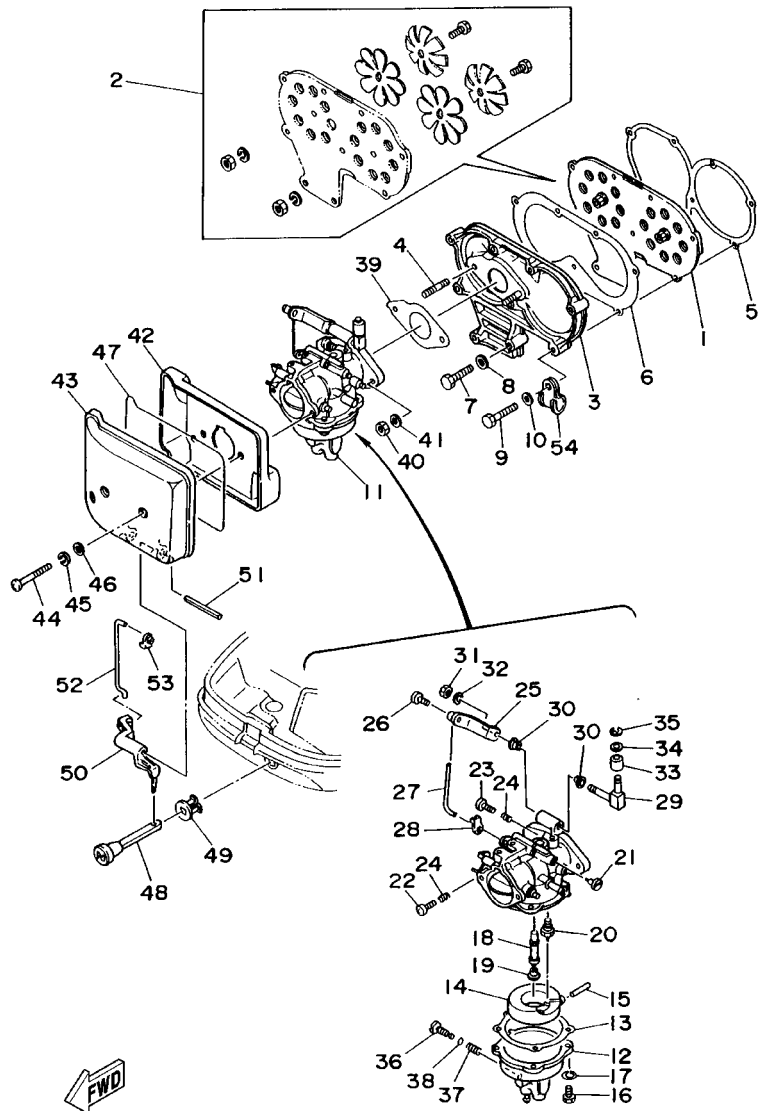

6950300-7040

FIG. 4 INTAKE ADMISSION

REF. NO.	PART NO. NO. PIECES	DESCRIPTION DESCRIPTION	25D				REMARKS REMARQUES
28	661-41262-02	.JOINT, CHOKE LEVER .RACCORD, LEVIER DE STARTER	1				
29	648-W4121-00	.SHEAVE SHAFT, ACCEL. LINK .AXE DE POULIE	1				
30	90386-05002	.BUSH .DOUILLE	2				
31	95303-05700	.NUT .ECROU	1				
32	92990-05100	.WASHER, SPRING .RONDELLE, GROWER	1				
33	664-41231-00	.COLLAR, GUIDE PIN .ENTRETOISE	1				
34	92990-05200	.WASHER, PLAIN .RONDELLE, PLATE	1				
35	93430-04031	.CIRCLIP .CIRCLIP, TYPE S	1				
36	646-14394-00	.VALVE, DRAIN .SOUPAPE, VIDANGE	1				
37	646-14223-01	.SPRING, DRAIN VALVE .RESSORT, CLAPET DE VIDANGE	1				
38	646-14397-00	.O-RING .JOINT, TORIQUE	1				
39	648-14198-A0	GASKET .JOINT	1				
40	95380-06600	NUT, HEXAGON .ECROU	2				
41	92995-06600	WASHER .RONDELLE	2				
42	695-14417-00	COVER 1 .COUVERCLE 1	1				
43	695-14418-01	COVER 2 .COUVERCLE 2	1				
44	97880-05030	SCREW, PAN HEAD .VIS, TETE TRONCONIQUE	2				
45	92990-05100	WASHER, SPRING .RONDELLE, GROWER	2				
46	92990-05600	WASHER, PLATE .RONDELLE, PLATE	2				
47	695-14476-00	SEAL .JOINT SPY	1				
48	682-41271-00	KNÖB, CHOKE .BOUTON DE STARTER	1				
49	689-41273-00	GROMMET .PASSE-FIL	1				
50	689-41252-01	LEVER, CHOKE 1 .LEVIER 1	1				
51	91690-40048	PIN, SPRING .GOUPILLE, ELASTIQUE	1				
52	695-41256-00	ROD, CHOKE 1 .TRINGLE 1, STARTER	1				
53	661-41262-02	.JOINT, CHOKE LEVER .RACCORD, LEVIER DE STARTER	1				
54	90461-06002	CLAMP .BRIDE	1				

FIG. 5 FUEL

CARBURANT

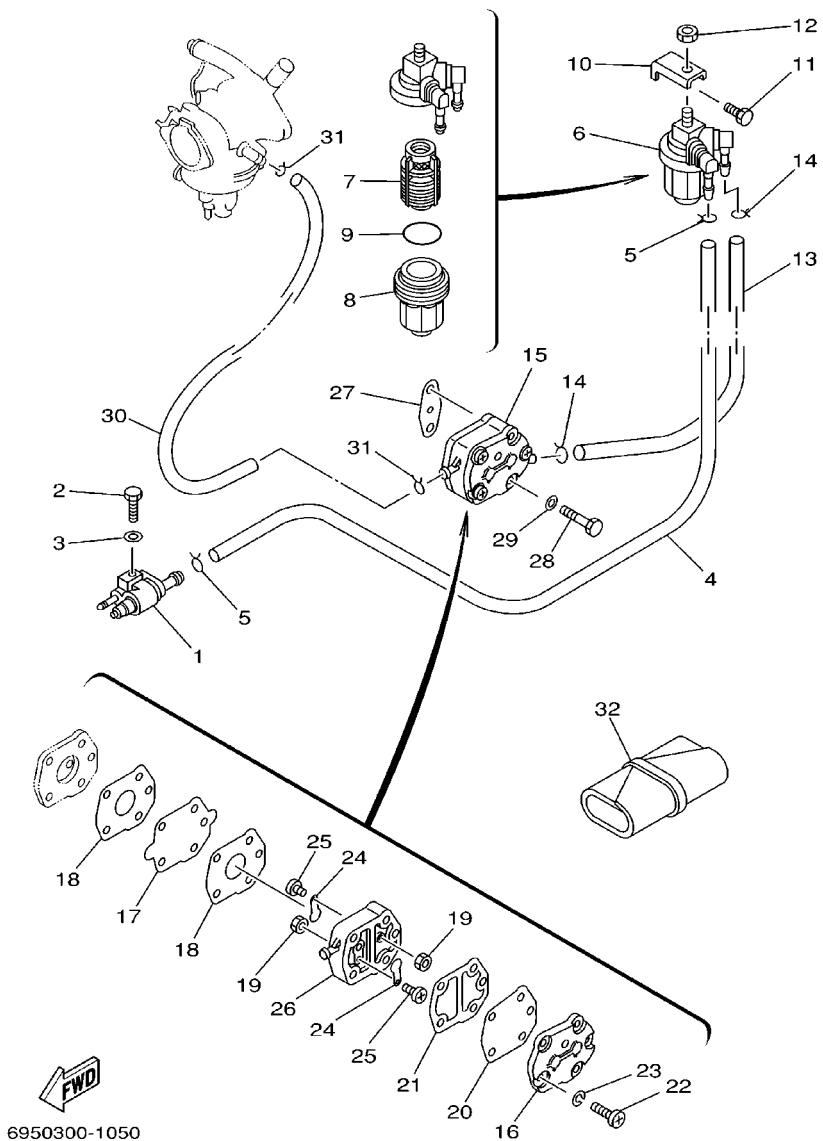

REF. NO.	PART NO. NO. PIECES	DESCRIPTION DESCRIPTION	25D				REMARKS REMARQUES
28	97095-06040	BOLT BOULON	2				
29	92995-06600	WASHER RONDELLE	2				
30	648-24312-01	PIPE 2 DURITE 2	1				
31	90467-08004	CLIP JONC	2				
32	656-W2810-02	TOOL KIT TROUSSE A OUTILS	1				

FIG. 6 STARTER

DEMARREUR

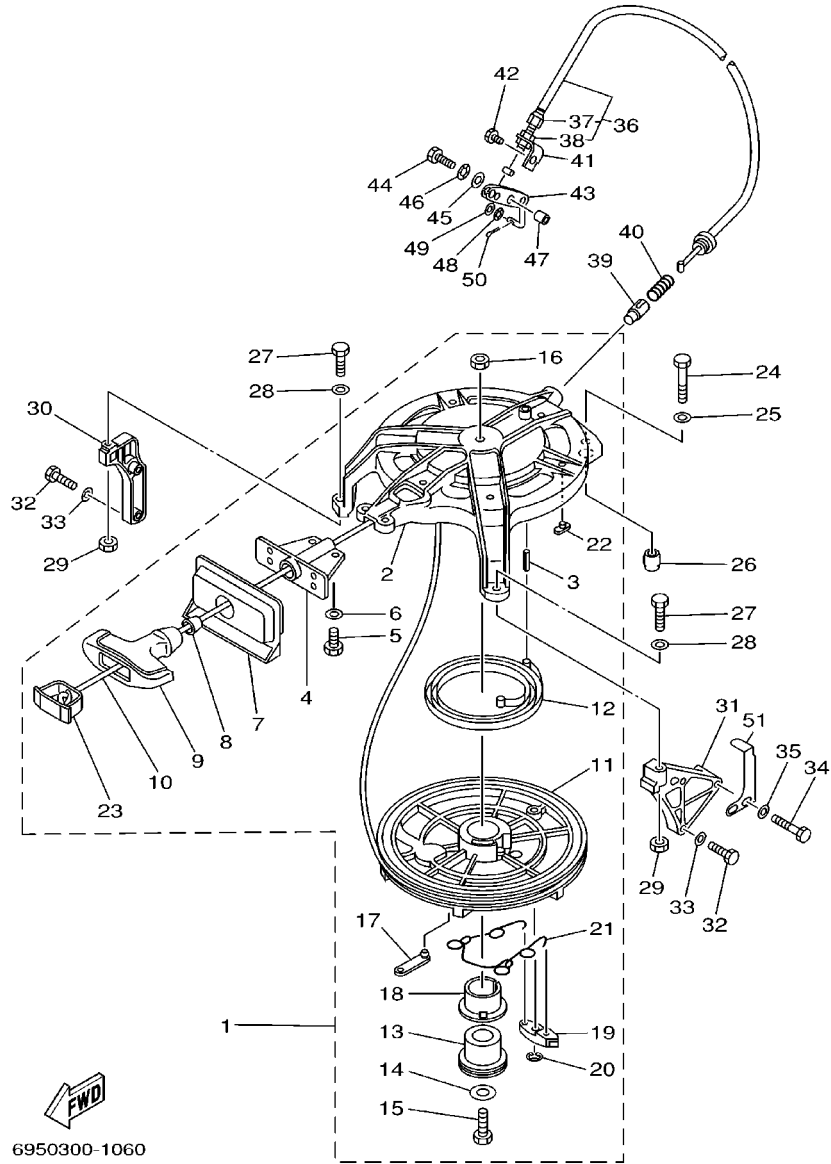

6950300-1060

REF. NO.	PART NO. NO. PIECES	DESCRIPTION DESCRIPTION	25D				REMARKS REMARQUES
1	689-15710-04	STARTER ASSY DEMARREUR COMPLET	1				
2	676-15711-01-94	.CASE, STARTER .CARTER DE DEMARREUR	1				
3	91690-40020	.PIN, SPRING .GOUPILLE, ELASTIQUE	2				
4	689-15758-02-94	.GUIDE, ROPE .GUIDE DE CABLE	1				
5	97095-06016	.BOLT .BOULON	2				
6	92995-06600	.WASHER .RONDELLE	2				
7	689-15762-01	.SEAL, RUBBER 2 .JOINT CAOUTCHOUC 2	1				
8	689-15789-00	.DAMPER .AMORTISSEUR	1				
9	689-15755-01	.HANDLE, STARTER .POIGNEE, DE DEMARREUR	1				
10	*	.WIRE (L:2095MM) .FIL (L:2095MM)	1				
11	676-15714-00-94	.DRUM, SHEAVE .TAMBOUR, POULIE	1				
12	90510-09M00	.SPRING, SPIRAL .RESSORT, HELICOIDAL	1				
13	676-15717-00	.SHAFT, STARTER .AXE DE DEMARREUR	1				
14	90201-08309	.WASHER, PLATE .RONDELLE, PLATE	1				
15	97013-08025	BOLT BOULON	1				
16	95303-08600	NUT ECROU	1				
17	676-15799-01	.CLIP .JONC	1				
18	90386-35M01	.BUSH .DOUILLE	1				
19	676-15741-03	.PAWL, DRIVE .CLIQUET, ENTRAINEMENT	1				
20	93430-06M02	.CIRCLIP .CIRCLIP, TYPE S	1				
21	676-15705-00	.SPRING, DRIVE PAWL .RESSORT DE CLIQUET	1				
22	676-15773-00	.STAY 3 .SUPPORT 3	6				
23	6F5-15779-02	.COVER .COUVERCLE	1				
24	97095-08035	BOLT BOULON	1				
25	92995-08600	WASHER RONDELLE	1				
* CUT FROM 50M ROLLS, PART NO. 90890-44373, CUTTING LENGTH 2.095M							
* A PRELEVER SUR BOBINE 50M , REFERENCE 90890-44373, LONGUEUR DE COUPE 2.095M							

FIG. 6 STARTER

DEMARREUR

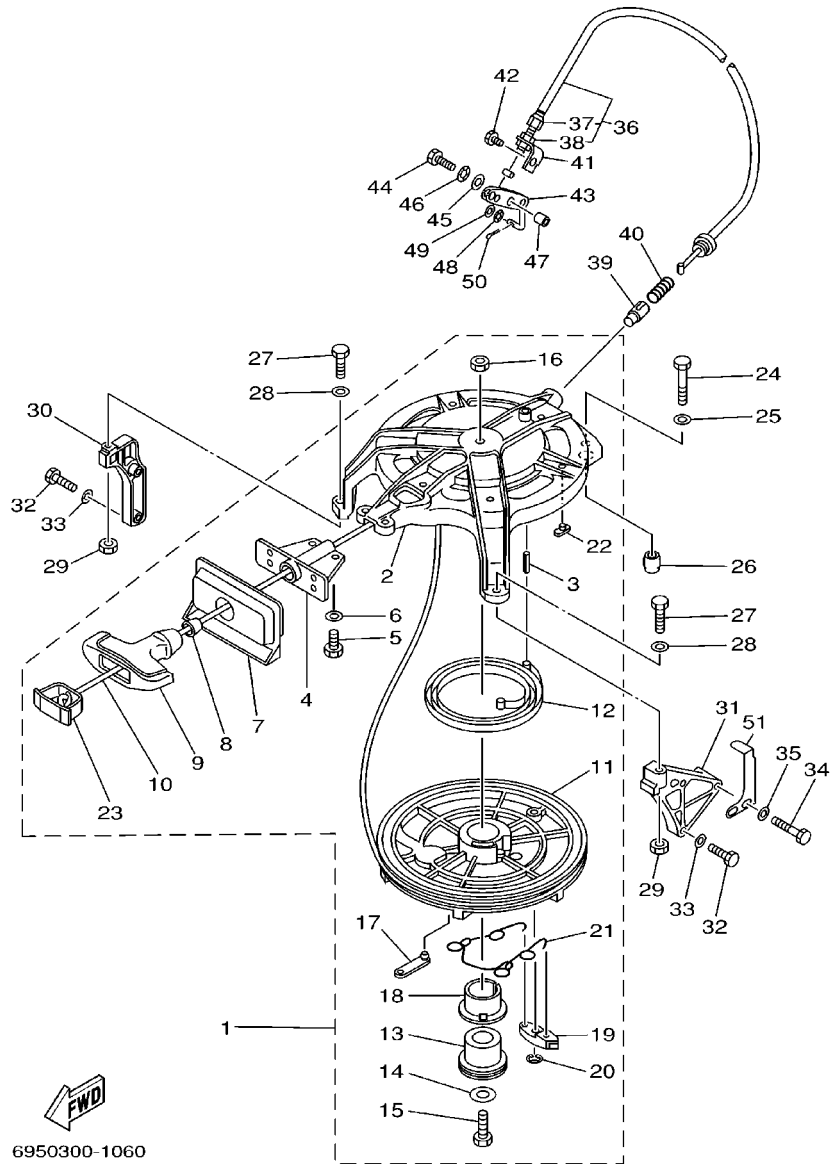

FWD
6950300-1060

REF. NO.	PART NO. NO. PIECES	DESCRIPTION DESCRIPTION	25D				REMARKS REMARQUES
26	99530-12016	PIN, DOWEL GOUJON, D'ASSEMBLAGE	1				
27	97095-06030	BOLT BOULON	2				
28	92995-06600	WASHER RONDELLE	2				
29	95380-06600	NUT, HEXAGON ECROU	2				
30	6H7-15771-01-94	STAY 1 SUPPORT 1	1				
31	656-15772-00-94	STAY 2 SUPPORT 2	1				
32	97013-06025	BOLT BOULON	4				
33	92903-06600	WASHER, PLATE RONDELLE, PLATE	4				
34	97013-06045	BOLT BOULON	1				
35	92903-06600	WASHER, PLATE RONDELLE, PLATE	1				
36	656-15770-00	CABLE COMP., STARTER STOP CABLE, BUTEE DE DEMAR	1				
37	90123-06049	BOLT BOULON	1				
38	95380-06600	NUT, HEXAGON ECROU	2				
39	656-15748-00	PLUNGER, STARTER STOP PLONGEUR, BOUTE DE DEMAR	1				
40	90501-10227	SPRING, COMPRESSION RESSORT, COMPRESSION	1				
41	656-15774-00	STAY 4 SUPPORT 4	1				
42	97095-06010	BOLT BOULON	1				
43	656-15749-00	LINK, STARTER STOP BIELLETTTE, BUTEE DE DEMAR	1				
44	97095-06020	BOLT BOULON	1				
45	92903-06600	WASHER, PLATE RONDELLE, PLATE	1				
46	90206-08010	WASHER, WAVE RONDELLE, ONDULEE	1				
47	90387-06568	COLLAR COLLERETTE	1				
48	90206-05005	WASHER, WAVE RONDELLE, ONDULEE	1				
49	92903-05600	WASHER, PLATE RONDELLE, PLATE	1				
50	91490-16010	PIN, COTTER GOUPILLE, FENDUE	1				
51	689-81332-01	PLATE, TIMING PLATEAU, ALLUMAGE	1				

FIG. 7 GENERATOR

GENERATRICE

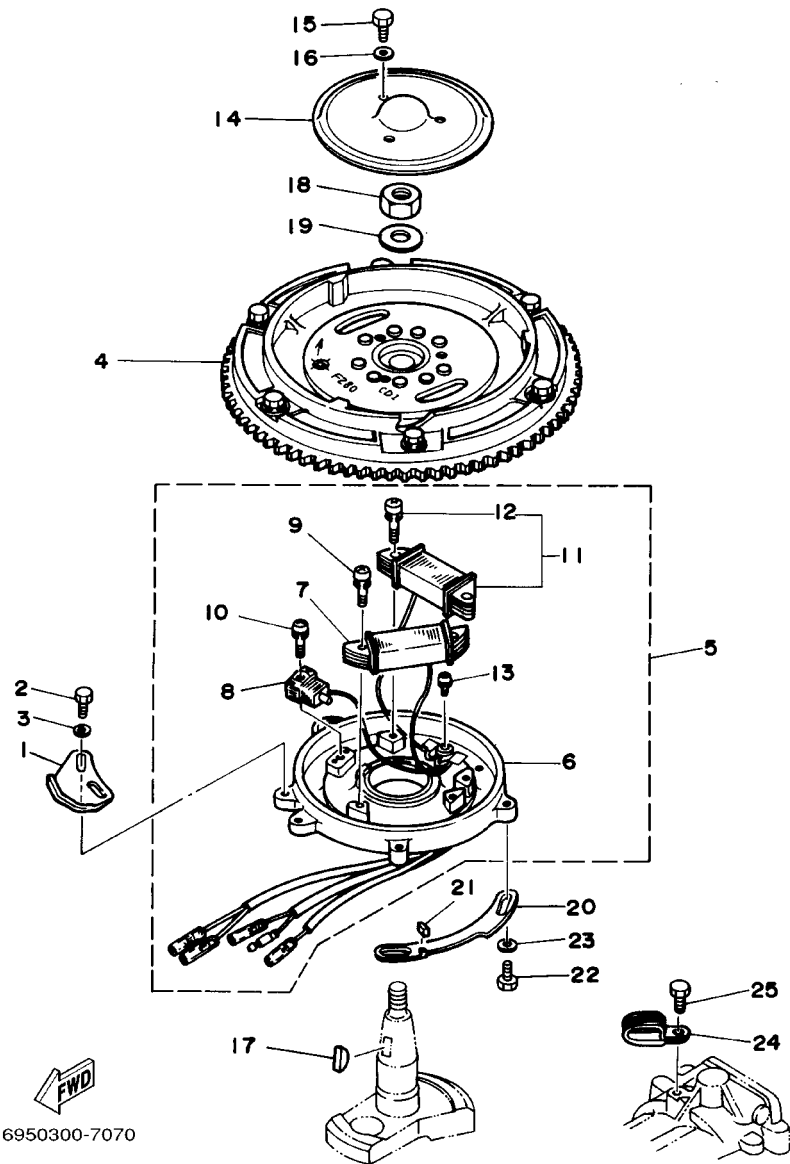

6950300-7070

REF. NO.	PART NO. NO. PIECES	DESCRIPTION DESCRIPTION	25D				REMARKS REMARQUES
1	695-41213-00-94	CAM, ACCEL. CAME, ACCELERATION	1				
2	97095-05012	BOULON	2				
3	92995-05600	WASHER RONDELLE	2				
4	695-85550-A0	ROTOR ASSY ROTOR CPLT	1				
5	695-85560-A0	BASE ASSY ENS. FLASQUE	1				
6	695-85561-70	.BASE, MAGNETO .BASE, MAGNETO	1				
7	695-85520-70	.COIL, CHARGE .BOBINE, CHARGE	1				
8	695-85580-70	.COIL, PULSER .BOBINE, PULSEUR	1				
9	90159-05039	.SCREW, WITH WASHER .VIS, AVEC RONDELLE	2				
10	90159-05038	.SCREW, WITH WASHER .VIS, AVEC RONDELLE	1				
11	695-81303-A0	.LIGHTING COIL ASSY .BOBINE D'ECLAIRAGE	1				
12	90159-05040	..SCREW, WITH WASHER ..VIS, AVEC RONDELLE	2				
13	90159-04035	.SCREW, WITH WASHER .VIS, AVEC RONDELLE	1				
14	648-81362-00	COVER, HOLE COUVERCLE, TROU	1				
15	97095-06012	BOULON	3				
16	92995-06600	WASHER RONDELLE	3				
17	90280-05013	KEY, WOODRUFF CLAVETTE, DEMI-LUNE	1				
18	90179-12M04	NUT ECROU	1				
19	90201-13M42	WASHER, PLATE RONDELLE, PLATE	1				
20	695-41615-00	STOPPER, MAGNETO BASE BUTEE, PLATEAU D'AVANCE	1				
21	695-44194-00	CAP CAPUCHON	1				
22	97013-06012	BOULON	2				
23	92903-06600	WASHER, PLATE RONDELLE, PLATE	2				
24	90461-06M01	CLAMP BRIDE	1				
25	97095-06010	BOULON	1				

FIG. 8 ELECTRICAL

PARTIE ELECTRIQUE

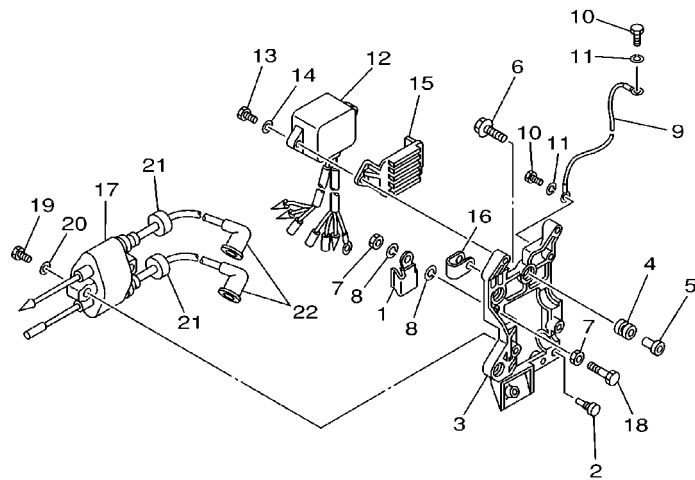

REF. NO.	PART NO. NO. PIECES	DESCRIPTION DESCRIPTION	25D				REMARKS REMARQUES
1	90465-08M13	CLAMP BRIDE	1				
2	689-85547-00	DAMPER AMORTISSEUR	1				
3	695-85542-00-94	BRACKET SUPPORT	1				
4	6A0-82317-00	DAMPER, IGNITION COIL AMORTISSEUR, BOBINE D'ALLUM	3				
5	624-42542-00	PIPE TUYAU	3				
6	90119-06M88	BOLT, WITH WASHER BOULON, AVEC RONDELLE	3				
7	95380-06600	NUT, HEXAGON ECROU	2				
8	92990-06100	WASHER, SPRING RONDELLE, GROWER	2				
9	689-82519-00	WIRE, EARTH LEAD FIL, MASSE	1				
10	97090-06012	BOLT BOULON	2				
11	92990-06100	WASHER, SPRING RONDELLE, GROWER	2				
12	695-85540-11	C.D.I. UNIT ASSY BLOC C.D.I.	1				
13	97095-06025	BOLT BOULON	2				
14	92995-06600	WASHER RONDELLE	2				
15	689-85548-01	HOLDER SUPPORT	1				
16	90464-12M00	CLAMP BRIDE	1				
17	680-85570-00	IGNITION COIL ASSY BOBINE D'ALLUMAGE (ENS.)	1				
18	97090-06020	BOLT BOULON	1				
19	97095-06025	BOLT BOULON	2				
20	92995-06600	WASHER RONDELLE	2				
21	90480-25161	GROMMET PASSE-FIL	2				
22	6G1-82370-21	PLUG CAP ASSY ANTIPARASITE	2				



6950300-1080

FIG. 9 BOTTOM COWLING

CAPOT INFERIEUR

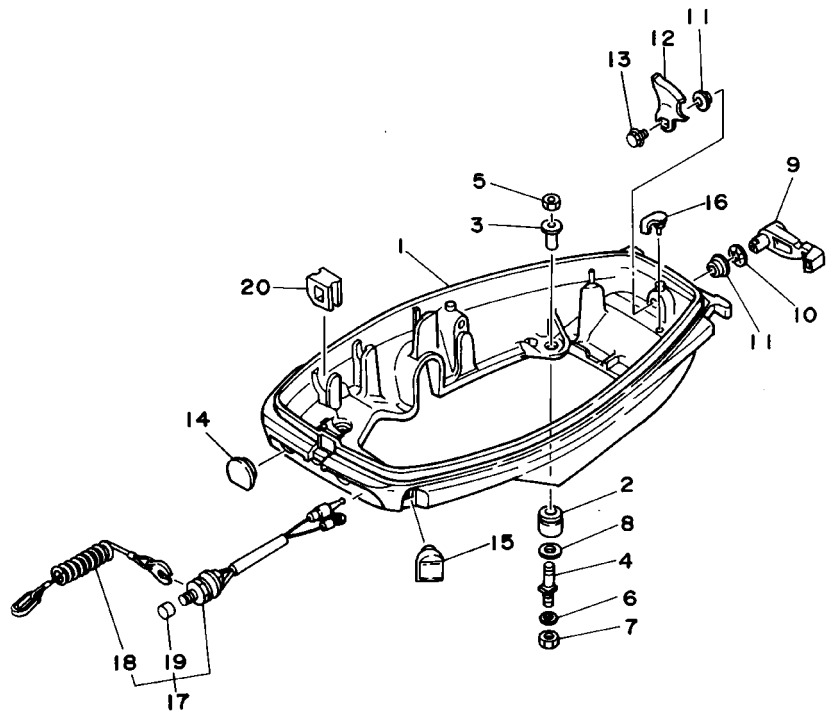

REF. NO.	PART NO. NO. PIECES	DESCRIPTION DESCRIPTION	25D				REMARKS REMARQUES
1	689-42711-04-4D	COWLING, BOTTOM CUVETTE	1				
2	90480-15M06	GROMMET PASSE-FIL	4				
3	90387-08M25	COLLAR COLLERETTE	4				
4	6G0-42796-00	BOLT 1 BOULON	4				
5	95380-08700	NUT ECROU	4				
6	92995-08600	WASHER RONDELLE	4				
7	95380-08700	NUT ECROU	4				
8	90201-08M87	WASHER, PLATE RONDELLE, PLATE	4				
9	689-42815-00	LEVER, CLAMP LEVIER, PRESSE	1				
10	90206-12052	WASHER, WAVE RONDELLE, ONDULEE	1				
11	90386-12069	BUSH DOUILLE	2				
12	689-42816-00	LEVER, CLAMP LEVIER, PRESSE	1				
13	90119-06M73	BOLT, WITH WASHER BOULON, AVEC RONDELLE	1				
14	682-42724-00	GROMMET PASSE-FIL	1				
15	689-42725-01	GROMMET PASSE-FIL	1				
16	647-42523-00	SPACER, FRICTION ENTRETOISE, FRICTION	1				
17	689-82575-04	ENGINE STOP SWITCH ASSY COUPE CIRCUIT CPLT	1				
18	682-82556-00	.STOPPER .PLAQUETTE	1				
19	689-8257Y-00	.CAP .CHAPEAU	1				
20	90480-17M08	GROMMET PASSE-FIL	1				



6950300-4090

FIG. 10 STEERING

DIRECTION

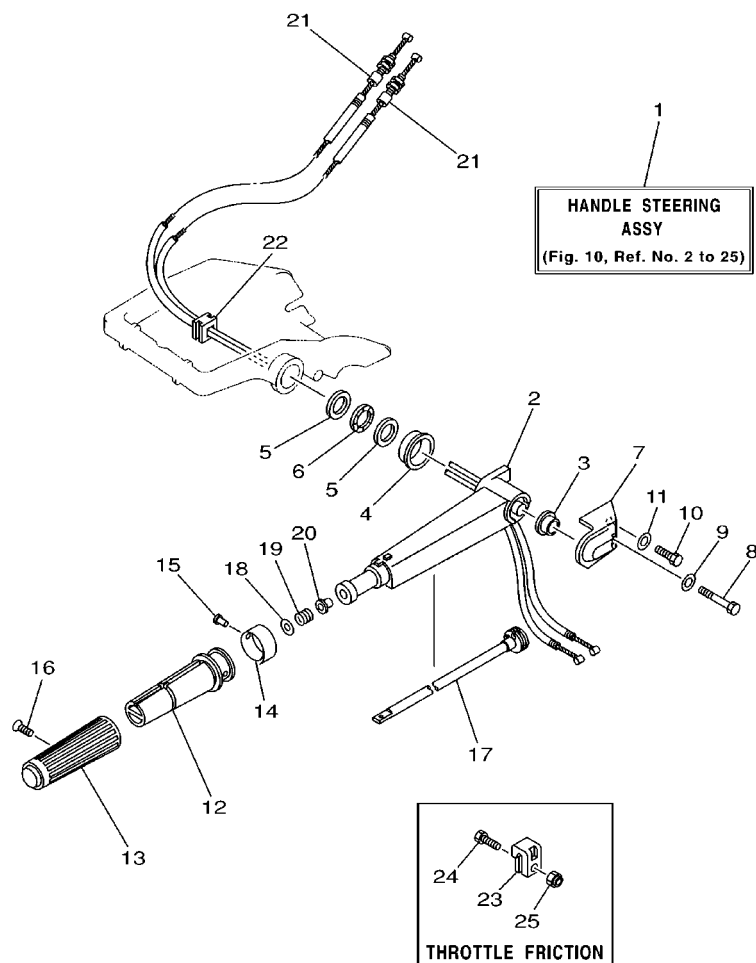

REF. NO.	PART NO. NO. PIECES	DESCRIPTION DESCRIPTION	25D				REMARKS REMARQUES
1	695-W0084-12-4D	HANDLE STEERING ASSY BARRE FRANCHE (ENS.)	1				
2	689-42111-01-4D	HANDLE, STEERING POIGNEE	1				
3	90387-13003	COLLAR COLLERETTE	1				
4	90387-33001	COLLAR COLLERETTE	1				
5	90201-28013	WASHER, PLATE RONDELLE, PLATE	2				
6	90206-28001	WASHER, WAVE RONDELLE, ONDULEE	1				
7	69P-42112-00-4D	HANDLE, STEERING POIGNEE	1				
8	97095-06050	BOLT BOULON	1				
9	92995-06600	WASHER RONDELLE	1				
10	97095-06020	BOLT BOULON	1				
11	92995-06600	WASHER RONDELLE	1				
12	664-42119-00	GRIP, STEERING HANDLE POIGNEE, BARRE FRANCHE	1				
13	6F6-42177-A0	RUBBER, HANDLE CAOUTCHOUC, POIGNEE	1				
14	695-42137-03	INDICATOR, THROTTLE INDICATEUR, ACCELERATION	1				
15	90269-02M09	RIVET RIVET	1				
16	90149-05M13	SCREW VIS	1				
17	689-42138-00	LEVER, THROTTLE LEVIER, ACCELERATEUR	1				
18	92903-10600	WASHER, PLATE RONDELLE, PLATE	1				
19	90501-23215	SPRING, COMPRESSION RESSORT, COMPRESSION	1				
20	90386-08032	BUSH DOUILLE	1				
21	689-26311-03	CABLE, THROTTLE 1 CABLE 1, ACCELERATEUR	2				
22	90480-12156	GROMMET PASSE-FIL	1				
23	656-42126-01	FRICTION, STEERING HANDLE GRIP CUVETTE, POIGNEE DE DIRECTION	1				
24	97095-06020	BOLT BOULON	1				
25	90185-06062	NUT, SELF-LOCKING ECROU, AUTO-BLOCANT	1				

6950300-1100

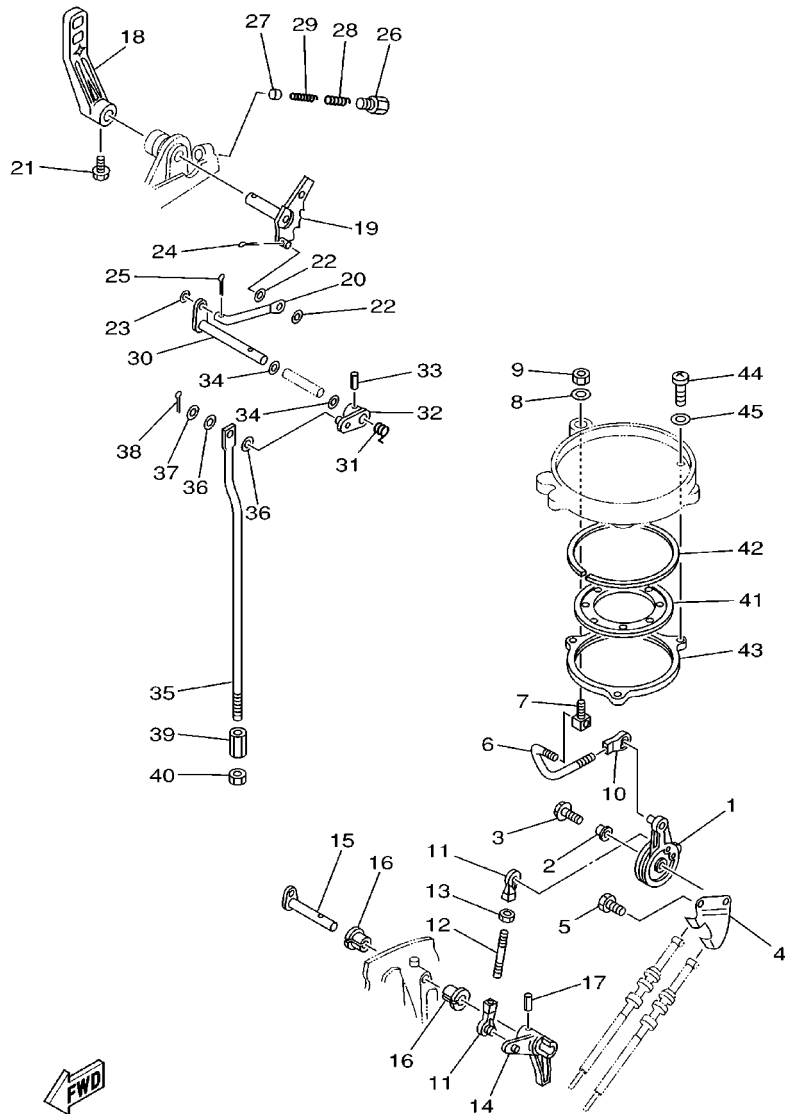

6950300-1110

FIG. 11 CONTROL

COMMANDE

REF. NO.	PART NO. NO. PIECES	DESCRIPTION DESCRIPTION	25D				REMARKS REMARQUES
1	664-41631-00-94	LEVER, MAGNETO CONTROL LEVIER, COMMANDE D'AVANCE	1				
2	90387-06M02	COLLAR COLLERETTE	1				
3	90119-06M49	BOLT, WITH WASHER BOULON, AVEC RONDELLE	1				
4	664-14497-00	STAY, THROTTLE WIRE SUPPORT DE BOISSEAU	1				
5	97095-06012	BOLT BOULON	1				
6	664-41636-00	ROD, MAGNETO CONTROL BIELLETTTE, COMMANDE D'AVANCE	1				
7	648-41635-00	SHAFT, LINK CONNECTING AXE, RACCORD	1				
8	90201-05556	WASHER, PLATE RONDELLE, PLATE	1				
9	95380-05600	NUT ECROU	1				
10	662-41237-01	JOINT, LINK RACCORD	1				
11	662-41237-01	JOINT, LINK RACCORD	2				
12	90116-05220	BOLT, STUD GOUJON	1				
13	95380-05600	NUT ECROU	1				
14	695-42154-00-94	LEVER, THROTTLE CONTROL LEVIER DE COMMANDE D'AVANCE	1				
15	656-42153-00-94	SHAFT, THROTTLE CONTROL AXE, COMMANDE D'ACCELERATION	1				
16	90386-10009	BUSH DOUILLE	2				
17	91690-40018	PIN, SPRING GOUPILLE, ELASTIQUE	1				
18	689-44111-01-4D	HANDLE, GEAR SHIFT POIGNEE, LEVIER D'EMBRAYAGE	1				
19	664-44113-01	CAM PLATE, HANDLE CAME, VERROUILLAGE	1				
20	664-44142-00	JOINT RACCORD	1				
21	90105-06M07	BOLT, WASHER BASED BOULON, AVEC RONDELLE	1				
22	90202-06007	WASHER, PLATE RONDELLE, PLATE	2				
23	92990-05600	WASHER, PLATE RONDELLE, PLATE	1				
24	91490-16010	PIN, COTTER GOUPILLE, FENDUE	1				
25	91490-12010	PIN, COTTER GOUPILLE, FENDUE	1				
26	664-42715-00	BUSHING COUSSINET	1				
27	664-44167-00	PLUNGER, SHIFT CAM POUSSOIR D'EMBRAYAGE	1				

C5

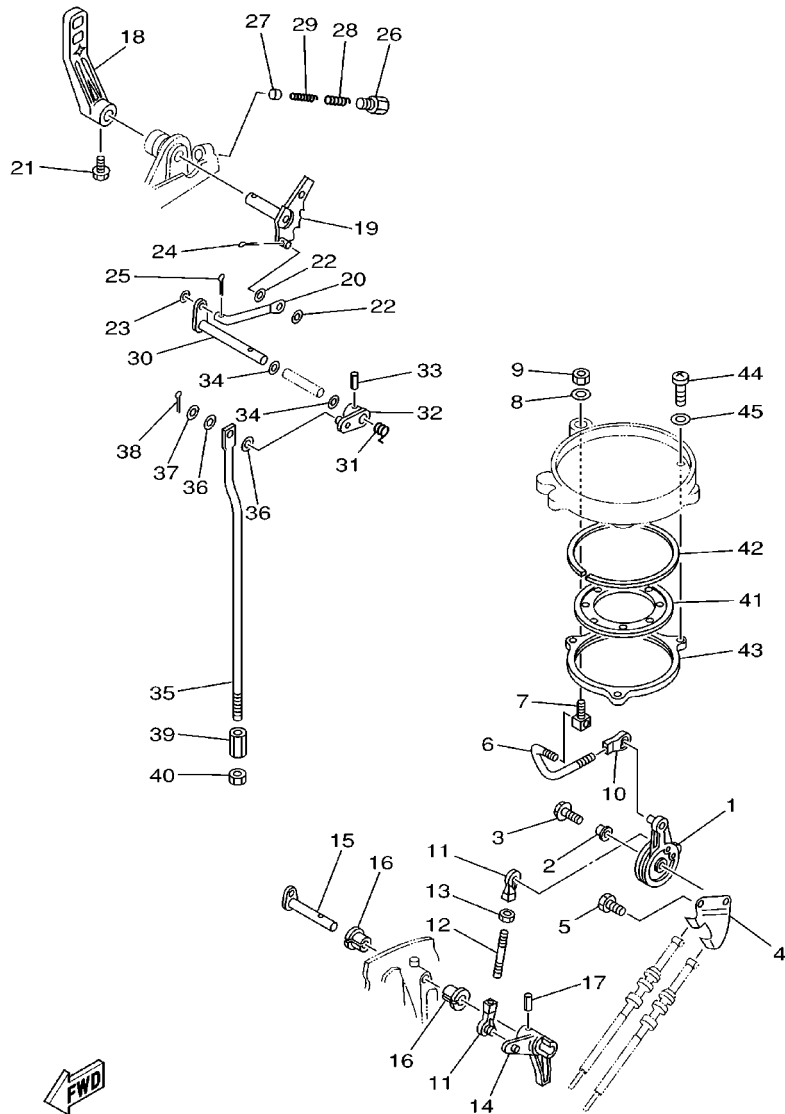

6950300-1110

FIG. 11 CONTROL

COMMANDE

REF. NO.	PART NO. NO. PIECES	DESCRIPTION DESCRIPTION	25D				REMARKS REMARQUES
28	90501-14M07	SPRING, COMPRESSION RESSORT, COMPRESSION	1				
29	90501-09M08	SPRING, COMPRESSION RESSORT, COMPRESSION	1				
30	689-44121-01	LEVER, SHIFT ROD LEVIER, TIGE D'INVERSION	1				
31	90508-14M13	SPRING, TORSION RESSORT, TORSION	1				
32	689-44125-00	LEVER, SHIFT ROD LEVIER, TIGE D'INVERSION	1				
33	91690-40016	PIN, SPRING GOUILLE, ELASTIQUE	1				
34	90202-10024	WASHER, PLATE RONDELLE, PLATE	2				
35	6G0-44143-00	ROD, SHIFT TIGE D'EMBRYAGE	1				
36	90202-06007	WASHER, PLATE RONDELLE, PLATE	2				
37	92990-05600	WASHER, PLATE RONDELLE, PLATE	1				
38	91490-20010	PIN, COTTER GOUILLE, FENDUE	1				
39	648-44146-00	CONNECTOR, SHIFT ROD CONNECTEUR, TIGE D'INVERSION	1				
40	90170-07021	NUT ECROU	1				
41	695-41612-00	RETAINER, MAGNETO BASE FLASQUE, PLATEAU D'AVANCE	1				
42	695-41613-00	PLATE, BASE FRICTION PLAQUE, FRICTION DE BASE	1				
43	695-41611-00-94	RETAINER, MAGNETO BASE FLASQUE, PLATEAU D'AVANCE	1				
44	97885-05010	SCREW, PAN HEAD VIS, TETE TRONCONIQUE	3				
45	92995-05600	WASHER RONDELLE	3				

FIG. 12 BRACKET 1

SUPPORT 1

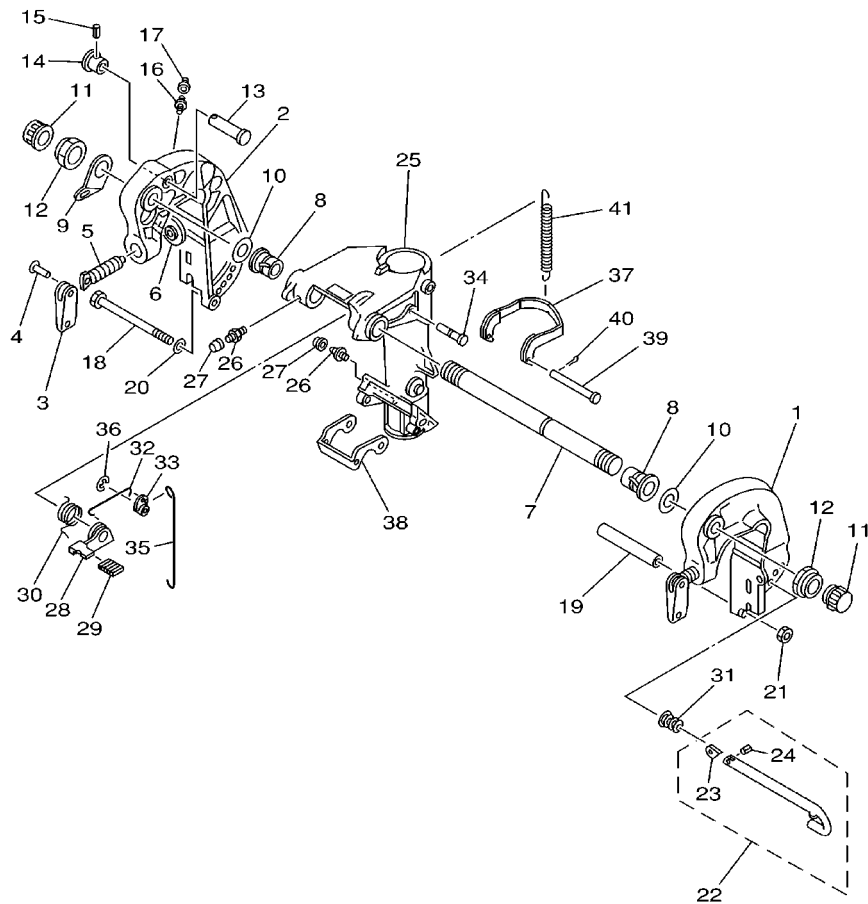

6950300-1120

REF. NO.	PART NO. NO. PIECES	DESCRIPTION DESCRIPTION	25D				REMARKS REMARQUES
1	689-43111-03-4D	BRACKET, CLAMP PRESSE	1				
2	689-43112-02-4D	BRACKET, CLAMP PRESSE	1				
3	6E0-43118-01	HANDLE, TRANSOM CLAMP POIGNEE DE VIS DE PRESSE	2				
4	90243-04M01	PIN GOUPILLE	2				
5	90149-14030	SCREW VIS	2				
6	648-43114-01	PAD, TRANSOM CLAMP RONDELLE D'APPUI	2				
7	6J8-43131-01	BOLT, CLAMP BRACKET BOULON, PRESSE	1				
8	90386-22M67	BUSH DOUILLE	2				
9	6J8-43113-01	PLATE, CLAMP BRACKET PLAQUETTE, PRESSE	1				
10	90201-22M03	WASHER, PLATE RONDELLE, PLATE	2				
11	6G5-43145-01	CAP, CLAMP BRACKET CAPUCHON, PRESSE	2				
12	90185-22043	NUT, SELF-LOCKING ECROU, AUTO-BLOCANT	2				
13	689-43191-00	SHAFT, STOPPER AXE, BUTEE	1				
14	689-43192-01	KNOB, STOPPER BOUTON, BUTEE DE RELEVAGE	1				
15	91690-30016	PIN, SPRING GOUPILLE, ELASTIQUE	1				
16	93700-06M03	NIPPLE, GREASE GRAISSEUR	1				
17	663-45119-00	CAP, GREASE NIPPLE CAPUCHON, GRAISSEUR	1				AP
18	90101-08339	BOLT BOULON	1				
19	90387-08M03	COLLAR COLLERETTE	1				
20	92995-08600	WASHER RONDELLE	1				
21	95380-08600	NUT ECROU	1				
22	689-43160-00	TILT ROD ASSY BROCHE D'INCLINAISON (ENS.)	1				
23	689-43165-00	PLATE, TILT LOCK TAQUET, BROCHE INCLINAISON	1				
24	91690-30008	PIN, SPRING GOUPILLE, ELASTIQUE	1				
25	689-43311-03-4D	BRACKET, SWIVEL 1 SUPPORT, PIVOT 1	1				
26	93700-06M03	NIPPLE, GREASE GRAISSEUR	3				
27	663-45119-00	CAP, GREASE NIPPLE CAPUCHON, GRAISSEUR	3				AP

FIG. 12 BRACKET 1

SUPPORT 1

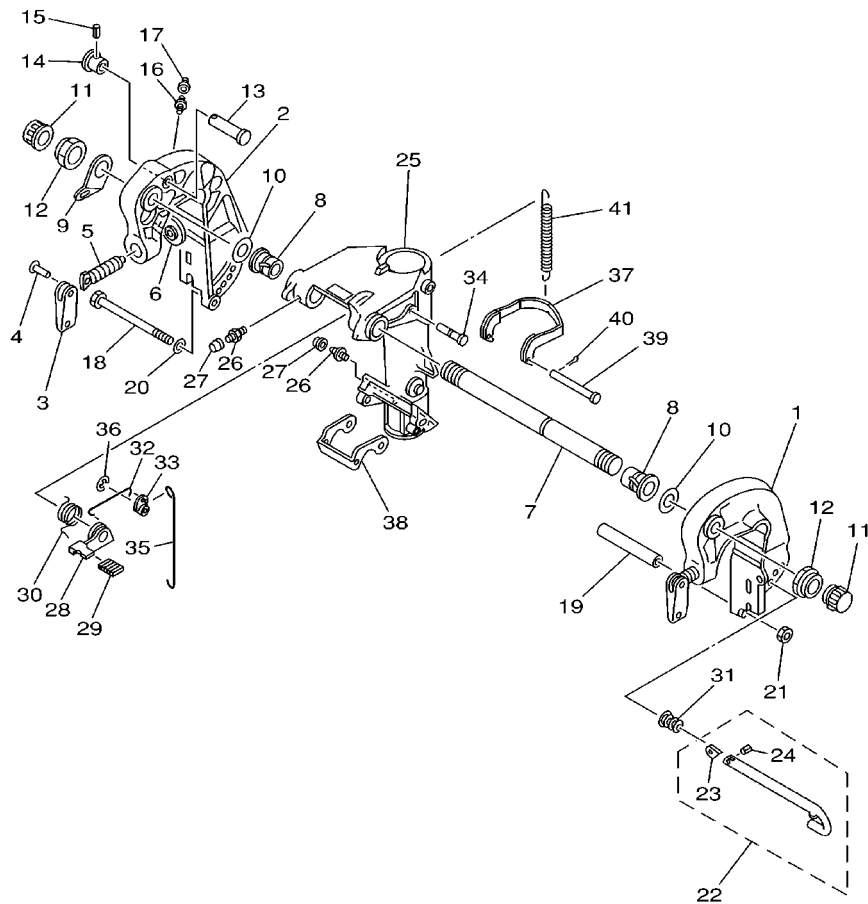

REF. NO.	PART NO. NO. PIECES	DESCRIPTION DESCRIPTION	25D				REMARKS REMARQUES
28	689-43631-00	LEVER, TILT LEVIER, INCLINAISON	1				
29	689-43633-00	COVER, TILT LEVER COUVERCLE	1				
30	689-43643-00	SPRING RESSORT	1				
31	90502-10M07	SPRING, CONICAL RESSORT, CONIQUE	1				
32	689-43616-00	ROD, TILT LOCK TIGE	1				
33	648-43642-00	LEVER, TILT 1 LEVIER, INCLINAISON 1	1				
34	90249-06M22	PIN GOUPILLE	1				
35	648-43617-00	ROD, TILT LOCK TIGE	1				
36	99080-05600	CIRCLIP CIRCLIP	1				
37	689-43614-01	PLATE, TILT LOCK ETRIER, VERROUILLAGE MARCHE AR	1				
38	648-43615-00	PLATE, TILT LOCK ETRIER, VERROUILLAGE MARCHE AR	1				
39	90240-05047	PIN, CLEVIS BOULON, A GOUPILLE	1				
40	91490-16010	PIN, COTTER GOUPILLE, FENDUE	1				
41	90506-30M27	SPRING, TENSION RESSORT, TENSION	1				

6950300-1120

D1

FIG. 13 BRACKET 2

SUPPORT 2

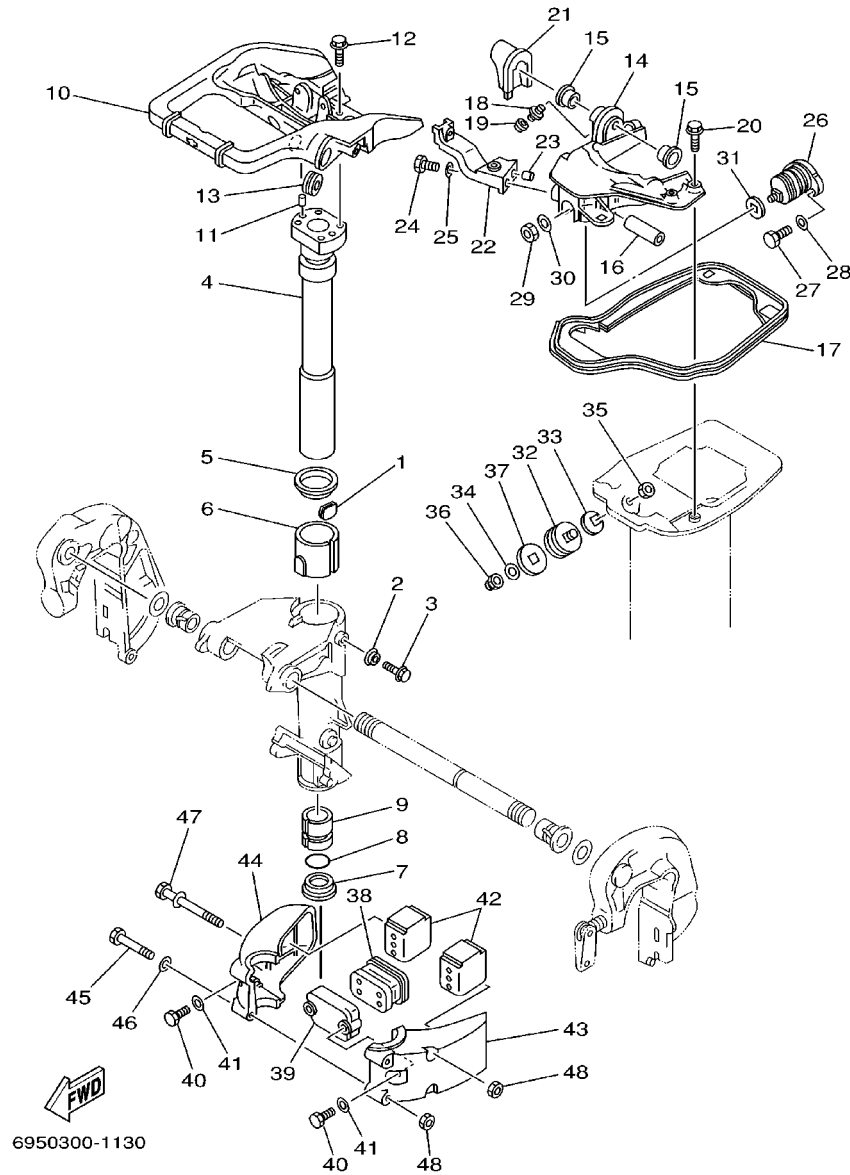

6950300-1130

REF. NO.	PART NO. NO. PIECES	DESCRIPTION DESCRIPTION	25D				REMARKS REMARQUES
1	648-42528-00	PLATE, FRICTION PLAQUE, FRICTION	1				
2	689-43373-01	SEAL, DAMPER JOINT	1				
3	90105-06M18	BOLT, WASHER BASED BOULON, AVEC RONDELLE	1				
4	689-42521-00-94	SHAFT, STEERING PIVOT AXE, PIVOT DE DIRECTION	1				
5	90209-47016	WASHER RONDELLE	1				
6	90386-47M22	BUSH DOUILLE	1				
7	90386-38022	BUSH DOUILLE	1				
8	93210-37160	O-RING JOINT TORIQUE	1				
9	90386-38090	BUSH DOUILLE	1				
10	69P-42511-00-4D	BRACKET, STEERING CADRE, DIRECTION	1				
11	93608-12063	PIN, DOWEL GOUJON	2				
12	90105-06M07	BOLT, WASHER BASED BOULON, AVEC RONDELLE	4				
13	90480-29045	GROMMET PASSE-FIL	1				
14	648-44518-01-94	BRACKET COMP. SUPPORT COMPLET	1				
15	90381-12M01	BUSH, SOLID DOUILLE, SOLIDE	2				
16	90387-10M39	COLLAR COLLERETTE	1				
17	689-42716-00	RUBBER, SEAL 1 JOINT EN CAOUTCHOUC 1	1				
18	93700-06M03	NIPPLE, GREASE GRAISSEUR	1				
19	663-45119-00	CAP, GREASE NIPPLE CAPUCHON, GRAISSEUR	1				AP
20	90105-06M08	BOLT, WASHER BASED BOULON, AVEC RONDELLE	4				
21	689-42718-00	RUBBER, SEAL 3 JOINT	1				
22	648-44519-00-94	BRACKET SUPPORT	1				
23	93606-12019	PIN, DOWEL GOUJON	1				
24	97090-06018	BOLT BOULON	1				
25	92990-06600	WASHER, PLATE RONDELLE, PLATE	1				
26	689-44516-00	MOUNT DAMPER, UPPER FRONT SILENT-BLOC, SUPERIEUR AVANT	1				
27	97095-06020	BOLT BOULON	2				

FIG. 13 BRACKET 2

SUPPORT 2

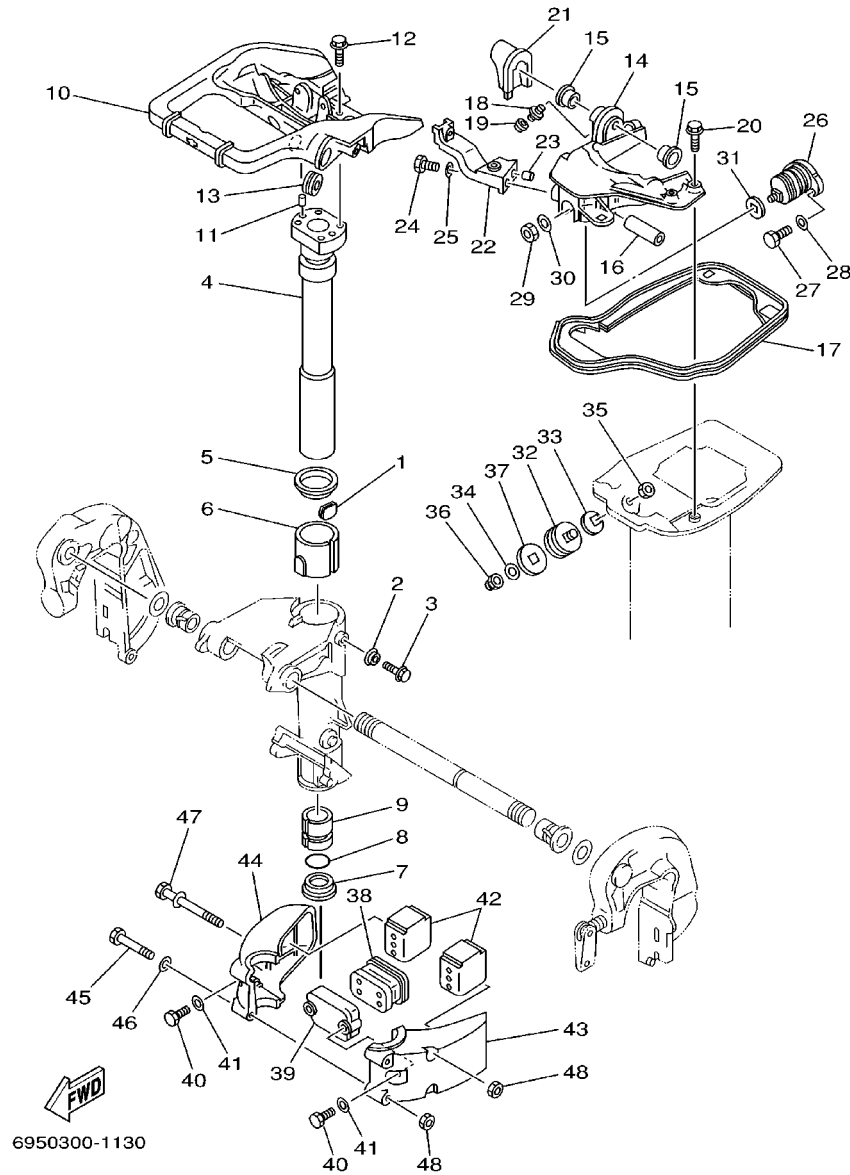

REF. NO.	PART NO. NO. PIECES	DESCRIPTION DESCRIPTION	25D				REMARKS REMARQUES
28	92995-06600	WASHER RONDELLE	2				
29	90170-10M42	NUT ECROU	1				
30	92990-10200	WASHER, PLAIN RONDELLE, PLATE	1				
31	648-44591-A0	GASKET JOINT	1				
32	664-44514-00-94	MOUNT DAMPER, UPPER SIDE SILENT-BLOC, SUPERIEUR LATERAL	2				
33	648-44591-A0	GASKET JOINT	2				
34	92990-10200	WASHER, PLAIN RONDELLE, PLATE	2				
35	90170-10M42	NUT ECROU	2				
36	90176-10M01	NUT, CROWN ECROU BORGNE	2				
37	664-44591-A0	GASKET JOINT	2				
38	689-44557-00	MOUNT DAMPER, LOWER FRONT SILENT-BLOC, INFRIEUR AVANT	1				
39	689-44553-00-94	COVER, LOWER MOUNT COUVERCLE, SUSPENSION INFRIEUR	1				
40	97075-08025	BOLT BOULON	2				
41	92995-08600	WASHER RONDELLE	2				
42	689-44555-00	MOUNT DAMPER, LOWER SIDE SILENT-BLOC, INFRIEUR LATERAL	2				
43	689-44551-01-4D	HOUSING, LOWER MOUNT RUBBER BOITIER, SILENT-BLOC INFRIEUR	1				
44	689-44552-01-4D	HOUSING, LOWER MOUNT RUBBER BOITIER, SILENT-BLOC INFRIEUR	1				
45	97095-08065	BOLT BOULON	2				
46	92995-08600	WASHER RONDELLE	2				
47	90119-08M03	BOLT, WITH WASHER BOULON, AVEC RONDELLE	2				
48	95380-08600	NUT ECROU	4				

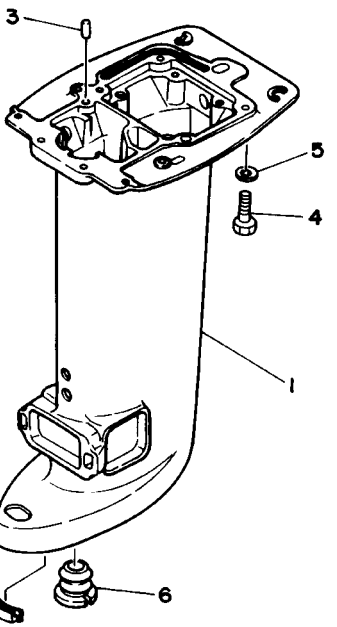
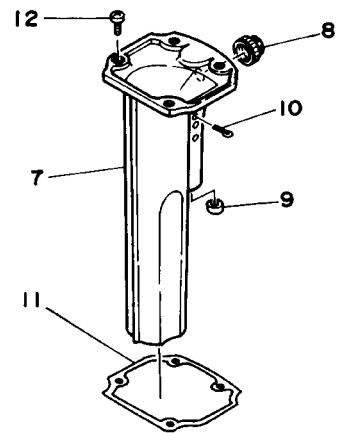

6950300-7140

FIG. 14 UPPER CASING FOURREAU

REF. NO.	PART NO. NO. PIECES	DESCRIPTION DESCRIPTION	25D				REMARKS REMARQUES
1	689-45111-04-4D	CASING, UPPER FOURREAU	1				S
	689-45111-13-4D	CASING, UPPER FOURREAU	1				L
2	61N-45375-00	DAMPER, SEAL BOURRELET, CAOUTCHOUC	1				L
3	93606-12019	PIN, DOWEL GOUJON	2				
4	97075-08030	BOLT BOULON	6				
5	92995-08600	WASHER RONDELLE	6				
6	689-45127-00	SEAL JOINT	1				S
7	664-41131-01-94	MANIFOLD, EXT. 1 PIPE D'ECHAPPEMENT	1				
8	664-41133-00	GASKET, EXHAUST MANIFOLD 1 JOINT, PIPE D'ECHAPPEMENT	1				
9	664-41135-00	GASKET, EXHAUST MANIFOLD JOINT, PIPE D'ECHAPPEMENT	1				
10	91490-30025	PIN, COTTER GOUPILLE, FENDUE	1				
11	664-41134-A0	GASKET, EXHAUST MANIFOLD JOINT, PIPE D'ECHAPPEMENT	1				
12	97880-06016	SCREW, PAN HEAD VIS, TETE TRONCONIQUE	4				

FIG. 15 LOWER CASING, DRIVE 1

BOITIER D'HELICE, TRANSMISSION 1

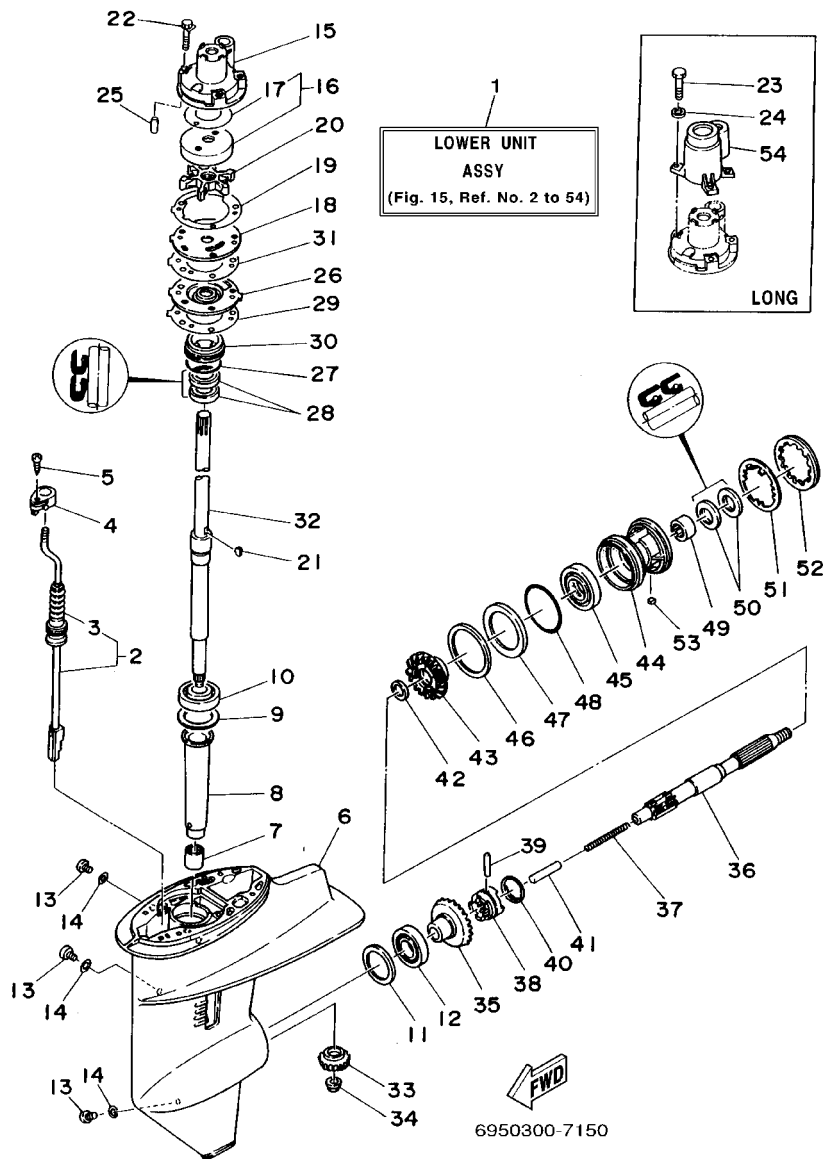

REF. NO.	PART NO. NO. PIECES	DESCRIPTION DESCRIPTION	25D				REMARKS REMARQUES
1	689-45300-06-4D	LOWER UNIT ASSY	1				S
	689-45300-16-4D	LOWER UNIT ASSY	1				L
2	695-44150-00	SHIFT CAM ASSY	1				S
	695-44150-10	SHIFT CAM ASSY	1				L
3	664-44147-00	.BOOT, SHIFT ROD	1				
4	689-44176-01	BRACKET SUPPORT	1				
5	97780-50110	SCREW, TAPPING	1				
6	689-45311-04-4D	CASING, LOWER	1				
7	93315-017U4	BEARING ROULEMENT	1				
8	689-45536-00	SLEEVE, DRIVE SHAFT	1				
9	664-45587-01-10	SHIM (T:0.10MM)	1				UR
	664-45587-01-12	SHIM (T:0.12MM)	1				UR
	664-45587-01-15	SHIM (T:0.15MM)	1				UR
	664-45587-01-18	SHIM (T:0.18MM)	1				UR
	664-45587-01-30	SHIM (T:0.30MM)	1				UR
	664-45587-01-40	SHIM (T:0.40MM)	1				UR
	664-45587-01-50	SHIM (T:0.50MM)	1				UR
10	93332-000U4	BEARING ROULEMENT	1				
11	664-45567-01-10	SHIM (T:0.10MM)	1				UR
	664-45567-01-12	SHIM (T:0.12MM)	1				UR
	664-45567-01-15	SHIM (T:0.15MM)	1				UR
	664-45567-01-18	SHIM (T:0.18MM)	1				UR
	664-45567-01-30	SHIM (T:0.30MM)	1				UR
	664-45567-01-40	SHIM (T:0.40MM)	1				UR
	664-45567-01-50	SHIM (T:0.50MM)	1				UR
12	93332-00005	BEARING ROULEMENT	1				
13	90340-08M04	PLUG, STRAIGHT SCREW	3				
		PLOT, FILETE DROIT					

D5

FIG. 15 LOWER CASING. DRIVE 1

BOITIER D'HELICE, TRANSMISSION 1

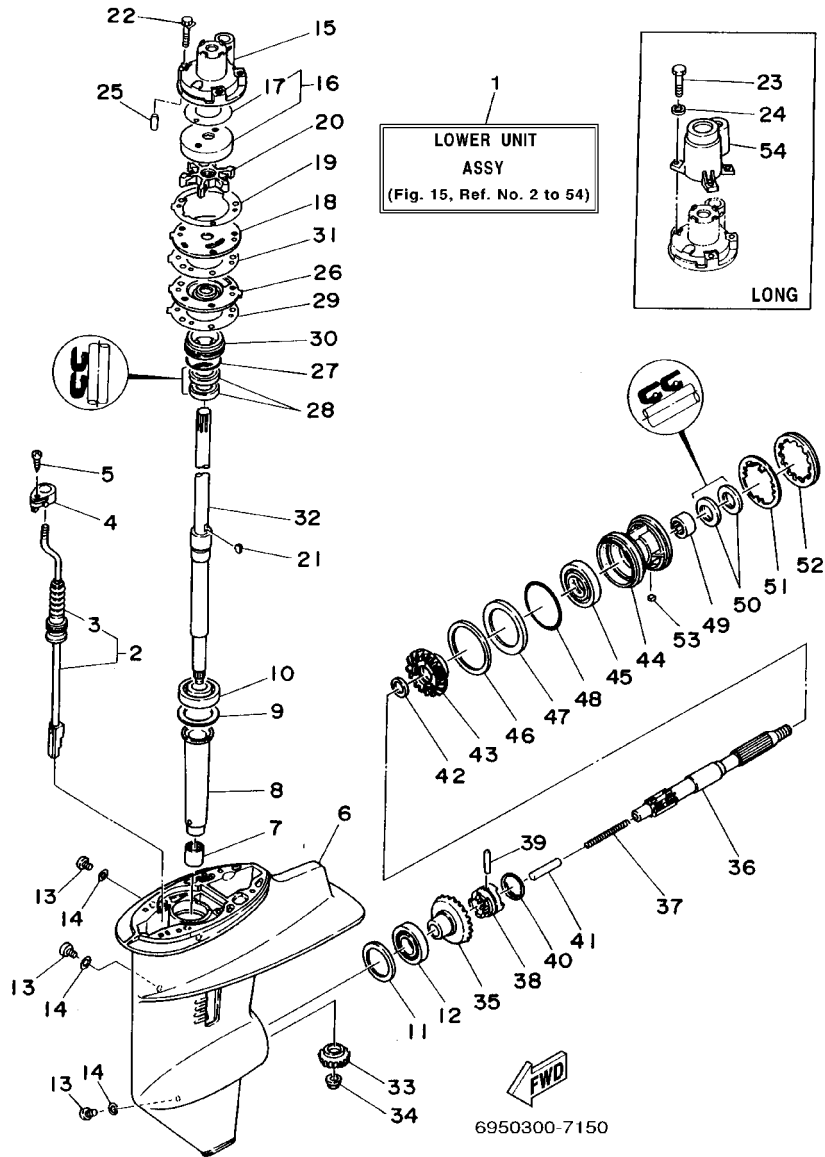

REF. NO.	PART NO. NO. PIECES	DESCRIPTION DESCRIPTION	25D				REMARKS REMARQUES
14	90430-08020	GASKET JOINT	3				
15	689-44311-03	HOUSING, WATER PUMP CORPS, POMPE A EAU	1				
16	689-W4432-02	INSERT CARTRIDGE COMP. CUVETTE COMP.	1				
17	689-44367-01	.DAMPER, WATER SEAL JOINT TUBE D'EAU	1				
18	689-44323-03	OUTER PLATE, CARTRIDGE PLAQUE EXTERIEURE	1				
19	689-44324-A0	GASKET, CARTRIDGE JOINT	1				
20	689-44352-02	IMPELLER TURBINE	1				
21	664-44338-00	KEY, WOODRUFF CLAVETTE, VOLANT	1				
22	90119-06M07	BOLT, WITH WASHER BOULON, AVEC RONDELLE	3				S
23	97095-06035	BOLT BOULON	3				L
24	92995-06600	WASHER RONDELLE	3				L
25	93604-10M03	PIN, DOWEL GOUJON	2				
26	689-44325-02-5B	PROTECTOR, OIL SEAL PROTECTEUR, JOINT D'HUILE	1				
27	93210-40M10	O-RING JOINT TORIQUE	1				
28	93101-22067	OIL SEAL JOINT SPY	2				
29	689-44315-A0	GASKET, WATER PUMP JOINT, POMPE A EAU	1				
30	689-45344-00-94	COVER, OIL SEAL FLASQE, JOINT D'HUILE	1				
31	689-44316-A0	GASKET, WATER PUMP JOINT, POMPE A EAU	1				
32	689-45501-00	DRIVE SHAFT COMP. ARBRE MOTEUR COMP.	1				S
	689-45501-10	DRIVE SHAFT COMP. ARBRE MOTEUR COMP.	1				L
33	689-45551-00	PINION PIGNON D'ATTAQUE	1				
34	90179-09M02	NUT ECROU	1				
35	689-45560-00	GEAR PIGNON	1				
36	689-45611-01	SHAFT, PROPELLER ARBRE, HELICE	1				
37	90501-10065	SPRING, COMPRESSION RESSORT, COMPRESSION	1				
38	664-45631-02	CLUTCH, DOG CRABOT	1				
39	90250-05010	PIN, STRAIGHT GOUPILLE, DROITE	1				

FIG. 15 LOWER CASING. DRIVE 1

BOITIER D'HELICE, TRANSMISSION 1

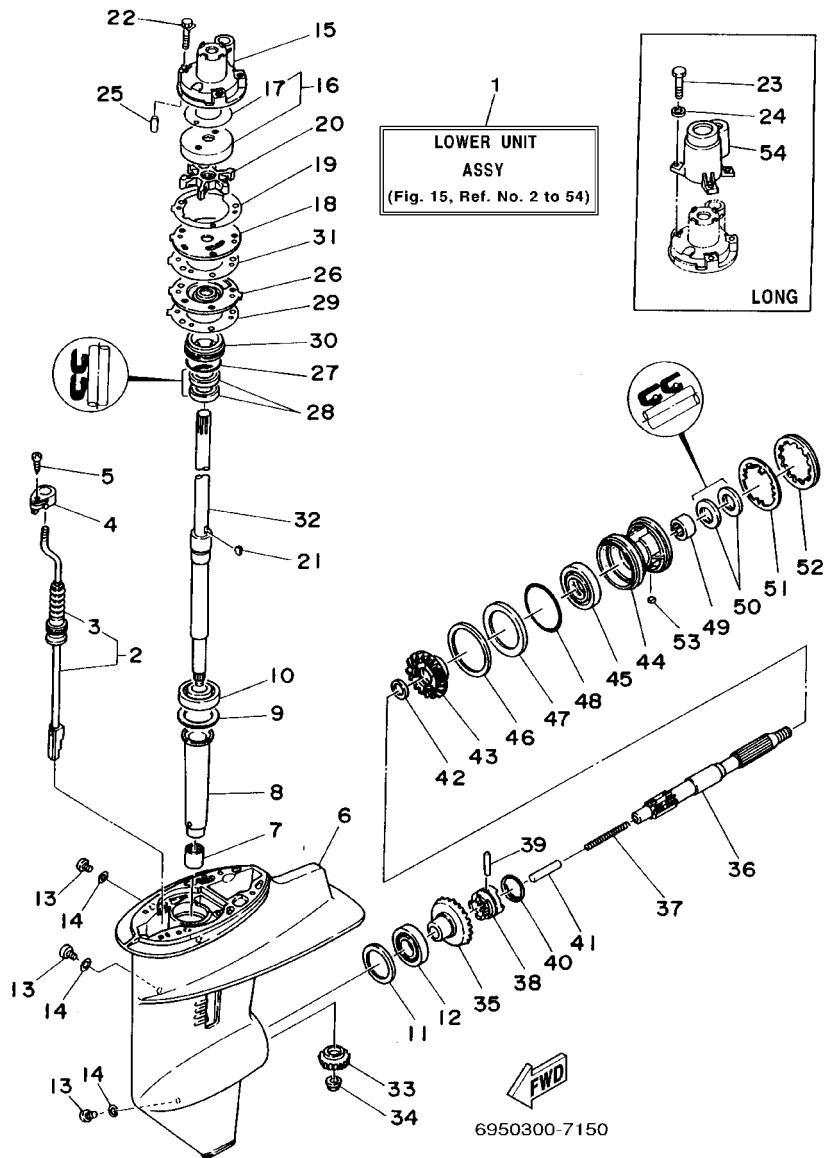

REF. NO.	PART NO. NO. PIECES	DESCRIPTION DESCRIPTION	25D				REMARKS REMARQUES
40	648-45633-00	RING, CROSS PIN JONC, GOUPILLE CRABOT	1				
41	648-45635-00	PLUNGER, SHIFT POUSOIR D'EMBRAYAGE	1				
42	90201-20417	WASHER, PLATE RONDELLE, PLATE	1				
43	689-45571-00	GEAR PIGNON	1				
44	689-45331-01-94	HOUSING, BEARING FLASQUE, ROULEMENT	1				
45	93306-00612	BEARING ROULEMENT	1				
46	664-45577-01-10	SHIM (T:0.10MM) CALE (T:0.10MM)	1				UR
	664-45577-01-12	SHIM (T:0.12MM) CALE (T:0.12MM)	1				UR
	664-45577-01-15	SHIM (T:0.15MM) CALE (T:0.15MM)	1				UR
	664-45577-01-18	SHIM (T:0.18MM) CALE (T:0.18MM)	1				UR
	664-45577-01-30	SHIM (T:0.30MM) CALE (T:0.30MM)	1				UR
	664-45577-01-40	SHIM (T:0.40MM) CALE (T:0.40MM)	1				UR
	664-45577-01-50	SHIM (T:0.50MM) CALE (T:0.50MM)	1				UR
47	664-45576-00	WASHER, THRUST RONDELLE DE CALAGE	1				
48	93210-60MA3	O-RING JOINT TORIQUE	1				
49	93315-22004	BEARING ROULEMENT	1				
50	93101-20M07	OIL SEAL JOINT SPY	2				
51	90214-45M02	WASHER, CLAW RONDELLE, A GRIFFES	1				
52	664-45384-02	NUT ECROU	1				
53	90282-04010	KEY, STRAIGHT CLAVETTE, DROITE	1				
54	689-44312-00-5B	COVER, WATER PUMP HOUSING COUVERCLE	1				L

FIG. 16 LOWER CASING, DRIVE 2

BOITIER D'HELICE, TRANSMISSION 2

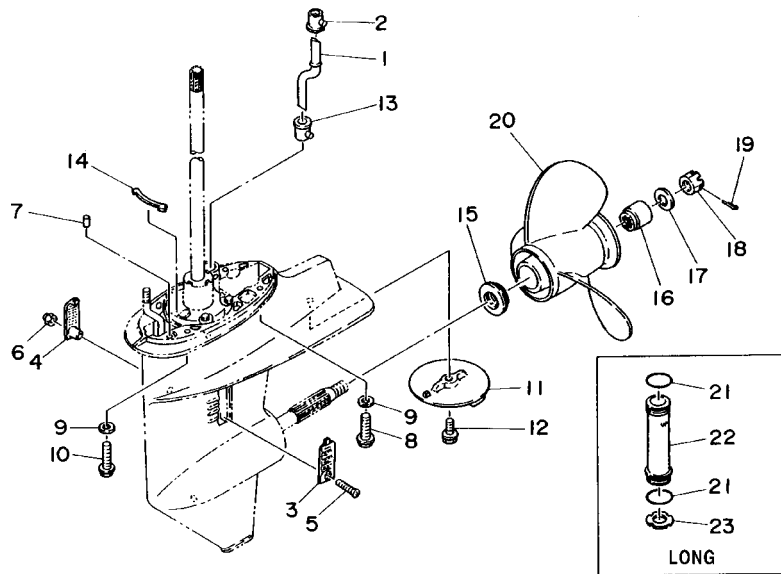

6950300-4160

REF. NO.	PART NO. NO. PIECES	DESCRIPTION DESCRIPTION	25D				REMARKS REMARQUES
1	664-44361-00	TUBE, WATER TUBE D'EAU	1				S
	689-44361-10	TUBE, WATER TUBE D'EAU	1				L
2	689-44366-00	DAMPER, WATER SEAL JOINT, TUBE D'EAU	1				
3	689-45214-01	COVER, WATER INLET GRILLE, ENTREE D'EAU	1				
4	689-45215-01	COVER, WATER INLET GRILLE, ENTREE D'EAU	1				
5	90152-05M04	SCREW, COUNTERSUNK VIS, TETE NOYEE	1				
6	90185-05002	NUT, SELF-LOCKING ECROU, AUTO-BLOCANT	1				
7	93606-11M24	PIN, DOWEL GOUJON	2				
8	90105-10059	BOLT, WASHER BASED BOULON, AVEC RONDELLE	2				
9	92990-10600	WASHER, PLATE RONDELLE, PLATE	4				
10	90105-10M12	BOLT, WASHER BASED BOULON, AVEC RONDELLE	2				
11	664-45371-01	TAB-TRIM ANODE DERIVE	1				
12	90105-08M02	BOLT, WASHER BASED BOULON, AVEC RONDELLE	1				
13	626-44365-01	DAMPER, WATER SEAL JOINT, TUBE D'EAU	1				
14	689-44314-00	SPACER ENTRETOISE	1				
15	664-45987-01	SPACER ENTRETOISE	1				
16	689-45997-00	SPACER ENTRETOISE	1				
17	92990-14200	WASHER, PLAIN RONDELLE, PLATE	1				
18	90171-14013	NUT, CASTLE ECROU, CRENELE	1				
19	91490-30022	PIN, COTTER GOUPILLE, FENDUE	1				
20	664-45941-01-EL	PROPELLER (3X9-7/8"X9"-F) HELICE (3X9-7/8"X9"-F)	1				UR
	664-45943-01-EL	PROPELLER (3X9-7/8"X8"-F) HELICE (3X9-7/8"X8"-F)	1				UR
	664-45945-00-EL	PROPELLER (3X9-7/8"X10-1/2"-F) HELICE (3X9-7/8"X10-1/2"-F)	1				UR
	664-45947-01-EL	PROPELLER (3X9-7/8"X11-1/4"-F) HELICE (3X9-7/8"X11-1/4"-F)	1				UR
	664-45949-02-EL	PROPELLER (3X9-7/8"X13"-F) HELICE (3X9-7/8"X13"-F)	1				UR
	664-45952-00-EL	PROPELLER (3X9-7/8"X14"-F) HELICE (3X9-7/8"X14"-F)	1				UR
21	93210-26130	O-RING JOINT TORIQUE	2				L

E1

FIG. 18 REPAIR KIT 1

KITS DE REPARATION 1

REF. NO.	PART NO. NO. PIECES	DESCRIPTION DESCRIPTION	25D				REMARKS REMARQUES
1	695-W0001-03	POWER HEAD GASKET KIT POCHETTE DE JINTS TETE MOTRICE	1				
2	695-14476-00	.SEAL .JOINT SPY	1				
3	648-13621-A1	.GASKET, VALVE SEAT .JOINT, SIEGE DE CLAPET	1				
4	648-13645-A0	.GASKET, MANIFOLD 1 .JOINT, TUBULURE 1	1				
5	648-14198-A0	.GASKET .JOINT	1				
6	648-14384-01	.GASKET, FLOAT CHAMBER .JOINT, CUVE DE FLOTTEUR	1				
7	695-11181-A1	.GASKET, CYLINDER HEAD 1 .JOINT, DE CULASSE 1	1				
8	655-12414-A1	.GASKET, COVER .JOINT, COUVERCLE	1				
9	664-15369-A0	.GASKET, OIL SEAL HOUSING .JOINT SPY DE LOGEMENT	1				
10	93102-23096	.OIL SEAL .JOINT SPY	1				
11	664-41114-A0	.GASKET, EXHAUST OUTER COVER .JOINT, COUVERCLE D'ECHAPPEMEN	2				
12	93210-16275	.O-RING .JOINT TORIQUE	1				
13	93210-58M21	.O-RING .JOINT TORIQUE	1				
14	93101-25M35	.OIL SEAL .JOINT SPY	1				
15	93101-16M36	.OIL SEAL .JOINT SPY	1				
16	689-45113-A1	.GASKET, UPPER CASING .JOINT, TUBE D'ARBRE	1				
17	93210-32738	.O-RING .JOINT TORIQUE	1				
18	650-24431-A0	.GASKET, FUEL PUMP 1 .JOINT 1 DE POMPE A ESSENCE	1				
19	689-W0093-02	CARBURETOR REPAIR KIT KIT DE REPARATION CARBURATEUR	1				
20	648-14198-A0	.GASKET .JOINT	1				
21	648-14384-01	.GASKET, FLOAT CHAMBER .JOINT, CUVE DE FLOTTEUR	1				
22	648-14385-00	.FLOAT .FLOTTEUR	1				
23	98580-04012	.SCREW, PAN HEAD .VIS, TETE TRONCONIQUE	4				
24	92990-04100	.WASHER, SPRING .RONDELLE, GROWER	4				
25	61K-14390-00	.NEEDLE VALVE ASSY .POINTEAU	1				
26	647-14323-00	.SCREW, AIR ADJUSTING .VIS DE DOSEUR D'AIR	1				
27	90386-05002	.BUSH .DOUILLE	2				

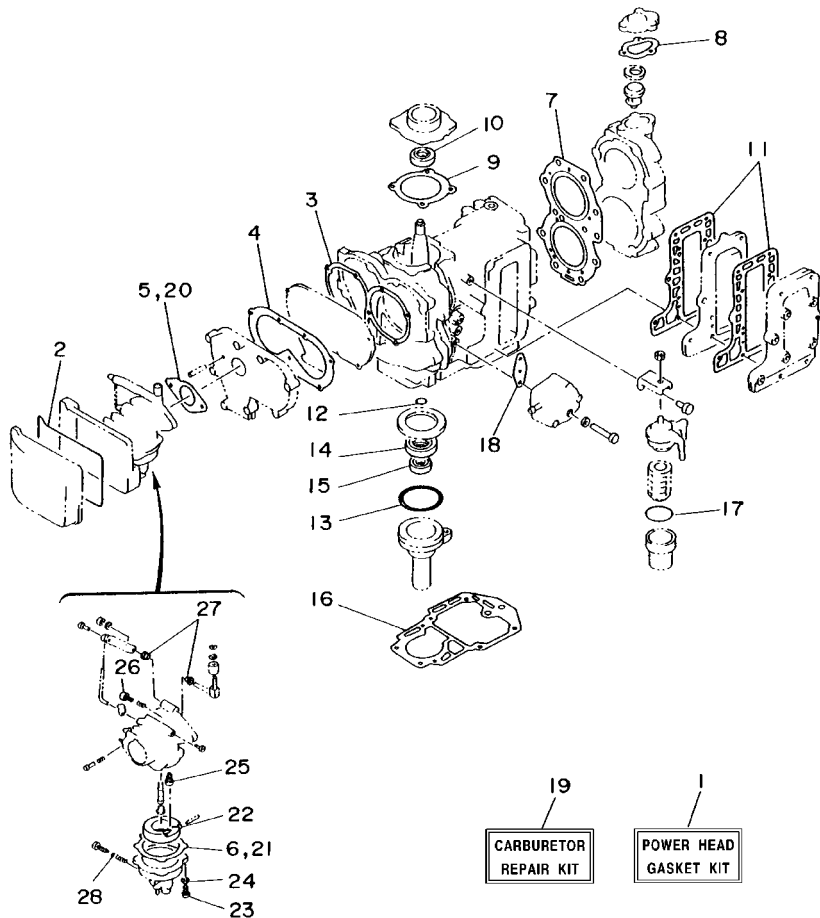

6950300-4180

FIG. 19 REPAIR KIT 2

KITS DE REPARATION 2

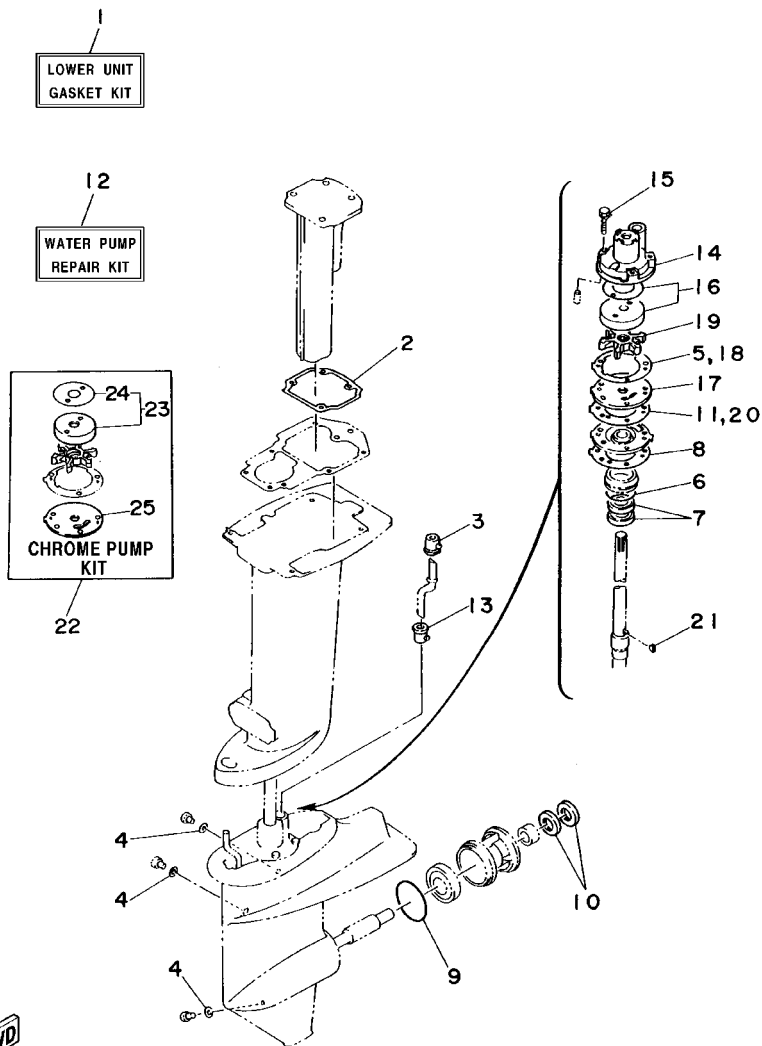

6950300-4190

REF. NO.	PART NO. NO. PIECES	DESCRIPTION DESCRIPTION	25D				REMARKS REMARQUES
1	689-W0001-23	LOWER UNIT GASKET KIT POCHETTE DE JOINTS EMBASE	1				
2	664-41134-A0	.GASKET, EXHAUST MANIFOLD JOINT, PIPE D'ECHAPPEMENT	1				
3	689-44366-00	.DAMPER, WATER SEAL JOINT, TUBE D'EAU	1				
4	90430-08020	.GASKET JOINT	3				
5	689-44324-A0	.GASKET, CARTRIDGE JOINT	1				
6	93210-40M10	.O-RING JOINT TORIQUE	1				
7	93101-22067	.OIL SEAL JOINT SPY	2				
8	689-44315-A0	.GASKET, WATER PUMP JOINT, POMPE A EAU	1				
9	93210-60MA3	.O-RING JOINT TORIQUE	1				
10	93101-20M07	.OIL SEAL JOINT SPY	2				
11	689-44316-A0	.GASKET, WATER PUMP JOINT, POMPE A EAU	1				
12	689-W0078-A6	WATER PUMP REPAIR KIT KIT DE REPARATION DE LA POMPE	1				
13	626-44365-01	.DAMPER, WATER SEAL JOINT, TUBE D'EAU	1				
14	689-44311-03	HOUSING, WATER PUMP .CORPS, POMPE A EAU	1				
15	90119-06M07	BOLT, WITH WASHER BOULON, AVEC RONDELLE	3				
16	689-W4432-02	.INSERT CARTRIDGE COMP. .CUVETTE COMP.	1				
17	689-44323-03	.OUTER PLATE, CARTRIDGE .PLAQUE EXTERIEURE	1				
18	689-44324-A0	.GASKET, CARTRIDGE JOINT	1				
19	689-44352-02	.IMPELLER .TURBINE	1				
20	689-44316-A0	.GASKET, WATER PUMP JOINT, POMPE A EAU	1				
21	664-44338-00	KEY, WOODRUFF .CLAVETTE, VOLANT	1				
22	689-W0078-3A	CHROME PUMP KIT KIT DE POMPE A EAU CHROMEE	1				
23	689-W4432-61	.INSERT CARTRIDGE COMP. .CUVETTE COMP.	1				
24	689-44367-01	.DAMPER, WATER SEAL JOINT TUBE D'EAU	1				
25	689-44323-43	.OUTER PLATE, CARTRIDGE .PLAQUE EXTERIEURE	1				

NUMERICAL INDEX
INDEX NUMERIQUE

PART NO. NO. PIECES	REF. NO.	PART NO. NO. PIECES	REF. NO.	PART NO. NO. PIECES	REF. NO.	PART NO. NO. PIECES	REF. NO.	PART NO. NO. PIECES	REF. NO.	PART NO. NO. PIECES	REF. NO.
689-W0001-23	19 - 1	646-14223-01	4 - 37	676-15773-00	6 - 22	661-41262-02	4 - 53	6J8-43131-01	12 - 7	664-44338-00	19 - 21
695-W0001-03	18 - 1	695-14301-02	4 - 11	656-15774-00	6 - 41	682-41271-00	4 - 48	6G5-43145-01	12 - 11	689-44352-02	15 - 20
689-W0004-00	4 - 2	647-14323-00	4 - 23	6F5-15779-02	6 - 23	689-41273-00	4 - 49	689-43160-00	12 - 22		19 - 19
695-W0070-12	1 - 11		18 - 26	689-15789-00	6 - 8	695-41611-00-94	11 - 43	689-43165-00	12 - 23	664-44361-00	16 - 1
689-W0078-A6	19 - 12	6A0-14325-00	5 - 25	676-15799-01	6 - 17	695-41612-00	11 - 41	689-43191-00	12 - 13	689-44361-10	16 - 1
689-W0078-3A	19 - 22	664-14327-01	4 - 26	6YK-24201-01	17 - 1	695-41613-00	11 - 42	689-43192-01	12 - 14	689-44362-00-94	16 - 22
695-W0084-12-4D	10 - 1	648-14334-00	4 - 24	6YK-24260-01	17 - 5	695-41615-00	7 - 20	689-43311-03-4D	12 - 25	626-44365-01	16 - 13
695-W0090-84-4D	2 - 1	648-14341-00	4 - 18	6YL-24268-01	17 - 2	695-41616-00	2 - 33	689-43373-01	13 - 2		19 - 13
689-W0093-02	18 - 19	648-14342-30	4 - 21	6G1-24304-02	5 - 1	664-41631-00-94	11 - 1	689-43614-01	12 - 37	689-44366-00	16 - 2
656-W2810-02	5 - 32	689-14343-73	4 - 19	6YL-24306-52	17 - 8	648-41635-00	11 - 7	648-43615-00	12 - 38		19 - 3
648-W4121-00	4 - 29	664-14381-01	4 - 12	664-24311-00	5 - 13	664-41636-00	11 - 6	689-43616-00	12 - 32	689-44367-01	15 - 17
689-W4432-02	15 - 16	648-14384-01	4 - 13	648-24312-01	5 - 30	689-42111-01-4D	10 - 2	648-43617-00	12 - 35		19 - 24
	19 - 16		18 - 6	6YL-24329-00	17 - 7	69P-42112-00-4D	10 - 7	689-43631-00	12 - 28	664-44514-00-94	13 - 32
689-W4432-61	19 - 23		18 - 21	692-24410-00	5 - 15	664-42119-00	10 - 12	689-43633-00	12 - 29	689-44516-00	13 - 26
695-11111-01-94	2 - 18	648-14385-00	4 - 14	663-24411-00	5 - 20	656-42119-00	10 - 23	648-43642-00	12 - 33	648-44518-01-94	13 - 14
695-11181-A1	2 - 19		18 - 22	692-24411-00	5 - 17	695-42137-03	10 - 14	689-43643-00	12 - 30	648-44519-00-94	13 - 22
	18 - 7	648-14386-00	4 - 15	6A0-24412-02	5 - 26	689-42138-00	10 - 17	689-44111-01-4D	11 - 19	689-44551-01-4D	13 - 43
689-11325-00	2 - 16	61K-14390-00	4 - 20	6A0-24413-00	5 - 16	656-42153-00-94	11 - 15	664-44113-01	11 - 19	689-44552-01-4D	13 - 44
650-11370-00	2 - 5		18 - 25	6A0-24421-01	5 - 24	695-42154-00-94	11 - 14	689-44121-01	11 - 30	689-44553-00-94	13 - 39
624-11379-00	2 - 4	646-14394-00	4 - 36	650-24431-A0	5 - 27	6F6-42177-A0	10 - 13	689-44125-00	11 - 32	689-44555-00	13 - 42
695-11400-00	3 - 1	646-14397-00	4 - 38		18 - 18	69P-42511-00-4D	13 - 10	664-44142-00	11 - 20	689-44557-00	13 - 38
695-11412-00	3 - 2		18 - 28	648-24434-01	5 - 18	689-42521-00-94	13 - 4	6G0-44143-00	11 - 35	648-44591-A0	13 - 31
6G0-11422-00	3 - 3	695-14417-00	4 - 42	648-24435-02	5 - 21	647-42523-00	9 - 16	648-44146-00	11 - 39		13 - 33
6G0-11432-00	3 - 4	695-14418-01	4 - 43	61N-24521-00	5 - 8	648-42528-00	13 - 1	664-44147-00	15 - 3	664-44591-A0	13 - 37
695-11442-00	3 - 5	695-14476-00	4 - 47	61N-24560-00	5 - 6	624-42542-00	8 - 5	695-44150-00	15 - 2	689-45111-04-4D	14 - 1
656-11515-00	3 - 13		18 - 2	61N-24563-00	5 - 7	695-42610-B2-4D	1 - 1	695-44150-10	15 - 2	689-45111-13-4D	14 - 1
664-11610-40	3 - 23	624-14485-00	2 - 3	648-24566-02	5 - 10	689-42613-01-4D	1 - 2	664-44167-00	11 - 27	689-45113-A1	2 - 32
664-11610-50	3 - 23	664-14497-00	11 - 4	6YK-24610-00	17 - 3	6G0-42615-00	1 - 6	689-44176-01	15 - 4		18 - 16
664-11610-80	3 - 23	695-15100-02-94	2 - 2	6YL-24641-00	17 - 4	689-42647-00	1 - 7	6E0-44191-11	1 - 16	663-45119-00	12 - 17
664-11631-80-96	3 - 22	664-15359-01-94	2 - 8	689-26311-03	10 - 21	6G0-42651-02	1 - 9	695-44194-00	7 - 21		12 - 27
648-11633-00	3 - 25	664-15369-A0	2 - 10	664-41111-00	2 - 27	695-42677-B1	1 - 12	689-44311-03	15 - 15		13 - 19
664-11635-80	3 - 22		18 - 9	664-41113-00-94	2 - 26	695-42678-12	1 - 13		19 - 14	689-45127-00	14 - 6
664-11636-80	3 - 22	689-15396-01-5B	3 - 16	664-41114-A0	2 - 28	695-42681-11	1 - 14	689-44312-00-5B	15 - 54	689-45214-01	16 - 3
648-11651-04	3 - 6	676-15705-00	6 - 21		18 - 11	695-42682-12	1 - 15	689-44314-00	16 - 14	689-45215-01	16 - 4
648-11681-00	3 - 7	689-15710-04	6 - 1	664-41131-01-94	14 - 7	689-42711-04-4D	9 - 1	689-44315-A0	15 - 29	689-45300-06-4D	15 - 1
6F5-12411-02	2 - 21	676-15711-01-94	6 - 2	664-41133-00	14 - 8	664-42715-00	11 - 26		19 - 8	689-45300-16-4D	15 - 1
655-12413-01-9M	2 - 22	676-15714-00-94	6 - 11	664-41134-A0	14 - 11	689-42716-00	13 - 17	689-44316-A0	15 - 31	689-45311-04-4D	15 - 6
655-12414-A1	2 - 23	676-15717-00	6 - 13		19 - 2	689-42718-00	13 - 21		19 - 11	689-45331-01-94	15 - 44
	18 - 8	676-15741-03	6 - 19	664-41135-00	14 - 9	682-42724-00	9 - 14		19 - 20	689-45344-00-94	15 - 30
689-13610-01	4 - 1	656-15748-00	6 - 39	648-41210-01	4 - 25	689-42725-01	9 - 15	689-44323-03	15 - 18	664-45371-01	16 - 11
648-13621-A1	4 - 5	656-15749-00	6 - 43	695-41213-00-94	7 - 1	6G0-42796-00	9 - 4		19 - 17	61N-45375-00	14 - 2
	18 - 3	689-15755-01	6 - 9	664-41231-00	4 - 33	689-42815-00	9 - 9	689-44323-43	19 - 25	664-45384-02	15 - 52
648-13641-01-94	4 - 3	689-15758-02-94	6 - 4	662-41237-01	11 - 10	689-42816-00	9 - 12	689-44324-A0	15 - 19	689-45501-00	15 - 32
648-13645-A0	4 - 6	689-15761-00	1 - 5		11 - 11	689-43111-03-4D	12 - 1		19 - 5	689-45501-10	15 - 32
	18 - 4	689-15762-01	6 - 7	656-41241-00	4 - 27	689-43112-02-4D	12 - 2		19 - 18	689-45536-00	15 - 8
648-14198-A0	4 - 39	656-15770-00	6 - 36	689-41252-01	4 - 50	6J8-43113-01	12 - 9	689-44325-02-5B	15 - 26	689-45551-00	15 - 33
	18 - 5	6H7-15771-01-94	6 - 30	695-41256-00	4 - 52	648-43114-01	12 - 6	689-44328-03	16 - 23	689-45560-00	15 - 35
	18 - 20	656-15772-00-94	6 - 31	661-41262-02	4 - 28	6E0-43118-01	12 - 3	664-44338-00	15 - 21	664-45567-01-10	15 - 11

NUMERICAL INDEX
INDEX NUMERIQUE

PART NO. NO. PIECES	REF. NO.	PART NO. NO. PIECES	REF. NO.	PART NO. NO. PIECES	REF. NO.	PART NO. NO. PIECES	REF. NO.	PART NO. NO. PIECES	REF. NO.	PART NO. NO. PIECES	REF. NO.
664-45567-01-12	15 - 11	695-85550-A0	7 - 4	90201-05556	11 - 8	90430-08020	15 - 14	92990-04100	4 - 17	93210-16275	3 - 14
664-45567-01-15	15 - 11	695-85560-A0	7 - 5	90201-08M87	9 - 8		19 - 4		18 - 24		18 - 12
664-45567-01-18	15 - 11	695-85561-70	7 - 6	90201-08309	6 - 14	90445-07260	2 - 14	92990-05100	4 - 32	93210-26130	16 - 21
664-45567-01-30	15 - 11	680-85570-00	8 - 17	90201-13M42	7 - 19	90445-09M25	5 - 4		4 - 45	93210-32738	5 - 9
664-45567-01-40	15 - 11	695-85580-70	7 - 8	90201-18522	3 - 27	90461-06M01	7 - 24		5 - 23		18 - 17
664-45567-01-50	15 - 11	90101-08339	12 - 18	90201-20417	15 - 42	90461-06002	4 - 54	92990-05200	4 - 34	93210-37160	13 - 8
689-45571-00	15 - 43	90105-06M07	11 - 21	90201-21567	2 - 24	90464-12M00	8 - 16	92990-05600	4 - 46	93210-40M10	15 - 27
664-45576-00	15 - 47		13 - 12	90201-22M03	12 - 10	90465-08M13	8 - 1		11 - 23		19 - 6
664-45577-01-10	15 - 46	90105-06M08	13 - 20	90201-28013	10 - 5	90467-06016	2 - 15		11 - 37	93210-58M21	3 - 19
664-45577-01-12	15 - 46	90105-06M18	13 - 3	90201-50306	3 - 15	90467-08004	5 - 5	92990-06100	8 - 8		18 - 13
664-45577-01-15	15 - 46	90105-08M02	16 - 12	90202-06007	11 - 22		5 - 14		8 - 11	93210-60MA3	15 - 48
664-45577-01-18	15 - 46	90105-10M12	16 - 10		11 - 36		5 - 31	92990-06600	13 - 25		19 - 9
664-45577-01-30	15 - 46	90105-10059	16 - 8	90202-10024	11 - 34	90480-12156	10 - 22	92990-10200	13 - 30	93306-00612	15 - 45
664-45577-01-40	15 - 46	90116-05220	11 - 12	90206-05005	6 - 48	90480-15M06	9 - 2		13 - 34	93306-305U3	3 - 10
664-45577-01-50	15 - 46	90116-06M30	4 - 4	90206-08010	6 - 46	90480-17M08	9 - 20	92990-10600	16 - 9	93310-522W0	3 - 9
664-45587-01-10	15 - 9	90119-06MA2	2 - 25	90206-12052	9 - 10	90480-25161	8 - 21	92990-14200	16 - 17	93315-017U4	15 - 7
664-45587-01-12	15 - 9	90119-06MA3	2 - 29	90206-28001	10 - 6	90480-29045	13 - 13	92995-05600	7 - 3	93315-22004	15 - 49
664-45587-01-15	15 - 9	90119-06MA4	2 - 30	90209-22071	3 - 8	90501-09M08	11 - 29		11 - 45	93332-000U4	15 - 10
664-45587-01-18	15 - 9	90119-06MA5	2 - 31	90209-47016	13 - 5	90501-10065	15 - 37	92995-06600	1 - 4	93332-00005	15 - 12
664-45587-01-30	15 - 9	90119-06M07	15 - 22	90214-45M02	15 - 51	90501-10227	6 - 40		3 - 21	93390-00009	3 - 11
664-45587-01-40	15 - 9		19 - 15	90240-05047	12 - 39	90501-14M07	11 - 28		4 - 41	93430-04031	4 - 35
664-45587-01-50	15 - 9	90119-06M49	11 - 3	90243-04M01	12 - 4	90501-23215	10 - 19		5 - 3	93430-06M02	6 - 20
689-45611-01	15 - 36	90119-06M73	9 - 13	90249-06M22	12 - 34	90502-10M07	12 - 31		5 - 29	93440-62057	3 - 12
664-45631-02	15 - 38	90119-06M88	8 - 6	90250-05010	15 - 39	90506-30M27	12 - 41		6 - 6	93450-20026	3 - 26
648-45633-00	15 - 40	90119-08M03	13 - 47	90266-04M00	1 - 10	90508-14M13	11 - 31		6 - 28	93602-20M02	3 - 24
648-45635-00	15 - 41	90119-08M66	2 - 7	90266-04M01	1 - 8	90510-09M00	6 - 12		7 - 16	93604-10M03	15 - 25
664-45941-01-EL	16 - 20	90119-08009	2 - 6	90269-02M09	10 - 15	91490-12010	11 - 25		8 - 14	93606-11M24	16 - 7
664-45943-01-EL	16 - 20	90119-08016	2 - 20	90280-05013	7 - 17	91490-16010	6 - 50		8 - 20	93606-12019	2 - 13
664-45945-00-EL	16 - 20	90123-06049	6 - 37	90282-04010	15 - 53		11 - 24		10 - 9		13 - 23
664-45947-01-EL	16 - 20	90149-05M13	10 - 16	90340-08M04	15 - 13		12 - 40		10 - 11		14 - 3
664-45949-02-EL	16 - 20	90149-14030	12 - 5	90381-12M01	13 - 15	91490-20010	11 - 38		13 - 28	93608-12063	13 - 11
664-45952-00-EL	16 - 20	90151-06M02	2 - 17	90386-05002	4 - 30	91490-30022	16 - 19		15 - 24	93700-06M03	12 - 16
664-45987-01	16 - 15	90152-05M04	16 - 5		18 - 27	91490-30025	14 - 10	92995-08600	6 - 25		12 - 26
689-45997-00	16 - 16	90157-05M16	17 - 6	90386-08032	10 - 20	91690-30008	12 - 24		9 - 6		13 - 18
695-81303-A0	7 - 11	90159-04035	7 - 13	90386-10009	11 - 16	91690-30016	12 - 15		12 - 20	94702-00272	2 - 36
689-81332-01	6 - 51	90159-05038	7 - 10	90386-12069	9 - 11	91690-40016	11 - 33		13 - 41	95303-05700	4 - 31
648-81362-00	7 - 14	90159-05039	7 - 9	90386-22M67	12 - 8	91690-40018	11 - 17		13 - 46	95303-08600	6 - 16
6A0-82317-00	8 - 4	90159-05040	7 - 12	90386-35M01	6 - 18	91690-40020	6 - 3		14 - 5	95380-03600	5 - 19
6G1-82370-21	8 - 22	90170-07021	11 - 40	90386-38022	13 - 7	91690-40048	4 - 51	93101-16M36	3 - 18	95380-05600	11 - 9
689-82519-00	8 - 9	90170-10M42	13 - 29	90386-38090	13 - 9	92903-05600	6 - 49		18 - 15		11 - 13
682-82556-00	9 - 18		13 - 35	90386-47M22	13 - 6	92903-06100	2 - 12	93101-20M07	15 - 50	95380-06600	2 - 35
689-8257Y-00	9 - 19	90171-14013	16 - 18	90387-06M02	11 - 2	92903-06600	4 - 8		19 - 10		4 - 40
689-82575-04	9 - 17	90176-10M01	13 - 36	90387-06568	6 - 47		4 - 10	93101-22067	15 - 28		6 - 29
695-85520-70	7 - 7	90179-09M02	15 - 34	90387-08M03	12 - 19		6 - 33		19 - 7		6 - 38
695-85540-11	8 - 12	90179-12M04	7 - 18	90387-08M25	9 - 3		6 - 35	93101-25M35	3 - 17		8 - 7
695-85542-00-94	8 - 3	90185-05002	16 - 6	90387-10M39	13 - 16		6 - 45		18 - 14	95380-08600	5 - 12
689-85547-00	8 - 2	90185-06062	10 - 25	90387-13003	10 - 3		7 - 23	93102-23096	2 - 9		12 - 21
689-85548-01	8 - 15	90185-22043	12 - 12	90387-33001	10 - 4	92903-10600	10 - 18		18 - 10		13 - 48

NUMERICAL INDEX
INDEX NUMERIQUE

PART NO. NO. PIECES	REF. NO.	PART NO. NO. PIECES	REF. NO.	PART NO. NO. PIECES	REF. NO.	PART NO. NO. PIECES	REF. NO.	PART NO. NO. PIECES	REF. NO.
95380-08700	9 - 5								
	9 - 7								
97013-06012	7 - 22								
97013-06014	5 - 11								
97013-06020	2 - 11								
	2 - 34								
97013-06025	4 - 7								
	6 - 32								
97013-06035	4 - 9								
97013-06045	6 - 34								
97013-08025	6 - 15								
97075-08025	13 - 40								
97075-08030	14 - 4								
97090-06012	8 - 10								
97090-06018	13 - 24								
97090-06020	8 - 18								
97095-05012	7 - 2								
97095-06010	6 - 42								
	7 - 25								
97095-06012	1 - 3								
	7 - 15								
	11 - 5								
97095-06016	6 - 5								
97095-06020	5 - 2								
	6 - 44								
	10 - 10								
	10 - 24								
	13 - 27								
97095-06022	3 - 20								
97095-06025	8 - 13								
	8 - 19								
97095-06030	6 - 27								
97095-06035	15 - 23								
97095-06040	5 - 28								
97095-06050	10 - 8								
97095-08035	6 - 24								
97095-08065	13 - 45								
97780-50110	15 - 5								
97880-05030	4 - 44								
97880-06016	14 - 12								
97885-05010	11 - 44								
98503-05028	5 - 22								
98580-04012	4 - 16								
	18 - 23								
98580-04014	4 - 22								
99080-05600	12 - 36								
99530-12016	6 - 26								

25DMH
PARTS CATALOGUE
©2000 by Yamaha Motor Co., Ltd.
1st Edition, Dec. 2000
All rights reserved.
Any reprinting or unauthorized use
without the written permission of
Yamaha Motor Co., Ltd.
is expressly prohibited.

25DMH
CATALOGUE DE PIÈCES DÉTACHÉES
©2000 Yamaha Motor Co., Ltd.
1ère Edition, Déc. 2000
Tous droits réservés.
Toute réimpression ou utilisation
sans la permission écrite de la
Yamaha Motor Co., Ltd.
est formellement interdite.