

**PARTS
CATALOGUE
CATALOGUE
DE PIÈCES DÉTACHÉES**

25B'02 (69R2)

30H'02 (69S2)

YAMAHA
GENUINE
Parts & Accessories

2A69R-300F1

FOREWORD

This Parts Catalogue is related to the parts for the model(s) in the below frame. When you are ordering replacement parts, please refer to this Parts Catalogue and quote both part numbers and part names correctly.

25B'02(69R2), 30H'02(69S2)

1. Modifications or additions which have been made after issue of the Parts Catalogue will be announced in the Yamaha Parts News. It is advisable that you make necessary corrections to the Parts Catalogue according to the Yamaha Parts News.

2. Abbreviations

The Following abbreviations are used in this Parts Catalogue.

“UR” Use specified parts number.

“UN” Use as many as needed.

“AP” Alternate Parts

“LM” Local Made

(Parts need to be ordered locally)

“O/S” Over Size

3. Parts, which are to be supplied in an assembly, are listed with a dot(.) in front of the part name as shown below.

EXAMPLE

CARBURETOR ASSY

.JET, PILOT

.NOZZLE, MAIN

4. Number of component for assembly

The numeral appearing to the right of each component part indicates the quantity of parts for each assembly unit.

EXAMPLE

PART NO.	DESCRIPTION	□	▣	▤	▥	REMARKS
6E0-85500-70	C.D.I. MAGNETO ASSY	1				
6E0-85550-70	.ROTOR ASSY	1				
6E0-15723-00-94.	.PULLY, STARTER	1				

5. Quantity Column Information

NAME for Q'TY COLUMN	APPLICABLE MODEL
25MH	25BMH
30MH	30HMH
25WC	25BWC
30WC	30HWC

6. Applicable Starting Serial No. and Color Code

1) Engine Starting Serial No.

25BMH	61RK S : 000500	30HMH	61TK S : 000546
	61RK L : 100716	30HWC	61TK S : 400306
25BWC	61RK S : 400136		

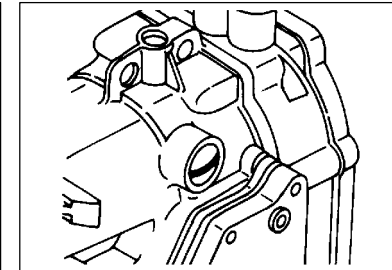
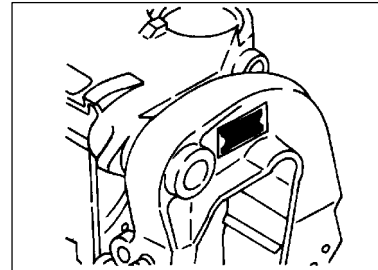

2) Color Code

Color Code	Color Name	Abbreviation
004D	DARK BLUISH GRAY METALLIC 2	DBNM2

7. Note that the illustrations for reference in finding parts numbers, not to be used for assembling. When assembling, please use the applicable service manual.

8. The asterisk (*) before a reference number indicates modification items after the first edition.

CONTENTS

SHEET 1/2

TOP COWLING	A4
CYLINDER. CRANKCASE	A5
CRANKSHAFT. PISTON	A7
INTAKE	B1
CARBURETOR	B3
FUEL	B4
STARTER	B6
GENERATOR	C1
ELECTRICAL 1	C2
ELECTRICAL 2	C4
ELECTRICAL 3	C5
STARTING MOTOR	C7
BOTTOM COWLING	D1
STEERING	D3
CONTROL 1	D4
CONTROL 2	D6
BRACKET 1	D7
BRACKET 2	E2
UPPER CASING	E4
LOWER CASING. DRIVE 1	E5
LOWER CASING. DRIVE 2	F1
FUEL TANK 1	F2
FUEL TANK 2	F3
REMOTE CONTROL BOX	F4
REMOTE CONTROL ASSY	F5
SWITCH. PANEL	F7

INDEX

NUMERICAL INDEX	G1
-----------------------	----

SHEET 2/2

REPAIR KIT 1	A4*
REPAIR KIT 2	A5*

INDEX

NUMERICAL INDEX	G1*
-----------------------	-----

FIG. 1 TOP COWLING

CAPOT SUPERIEUR

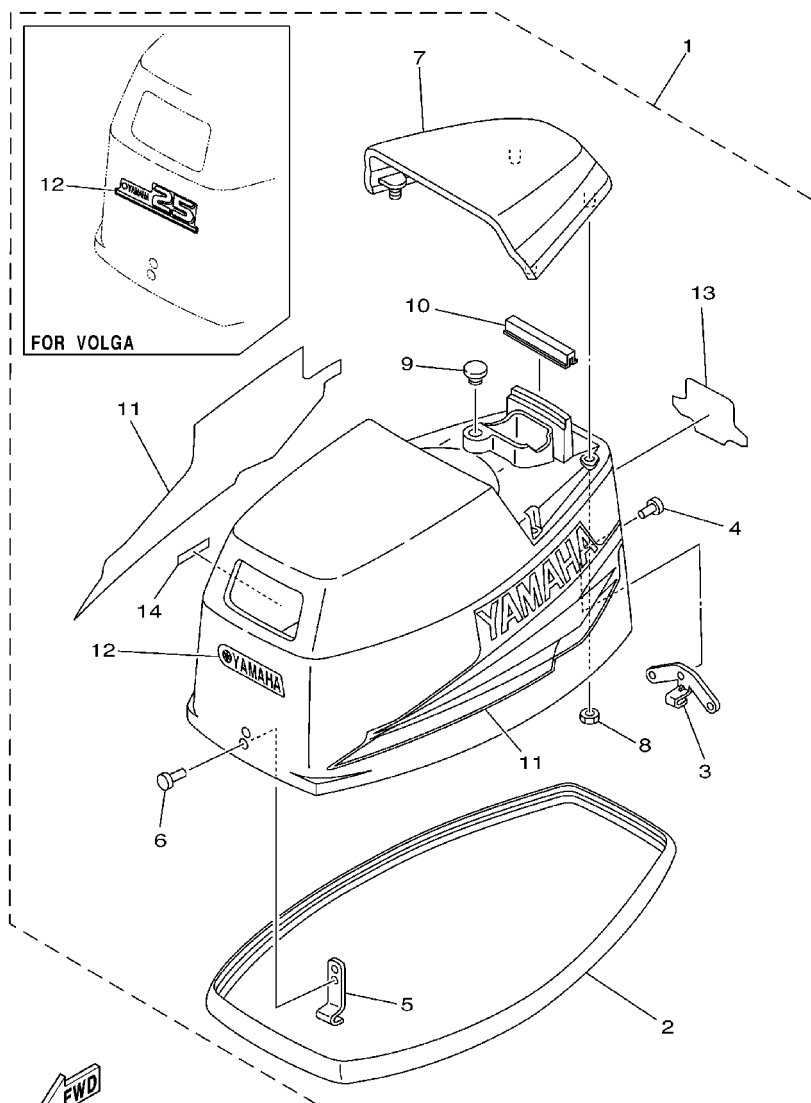

69R2300-2010

REF. NO.	PART NO. NO. PIECES	DESCRIPTION DESCRIPTION	25MH	30MH	25WC	30WC	REMARKS REMARQUES
1	69R-42610-30-4D	TOP COWLING ASSY CAPOT (ENS.)	1				
	69R-42610-20-4D	TOP COWLING ASSY CAPOT (ENS.)	1		1		FOR VOLGA
	69S-42610-20-4D	TOP COWLING ASSY CAPOT (ENS.)		1		1	FOR VOLGA
2	6G0-42615-00	.SEAL .JOINT	1	1	1	1	
3	689-42647-00	.HOLDER, CLAMP BAND .SUPPORT, SANDOW DE SERRAGE	1	1	1	1	
4	90266-04M01	.RIVET .RIVET	3	3	3	3	
5	6G0-42651-02	.HOOK .CROCHET	1	1	1	1	
6	90266-04M00	.RIVET .RIVET	2	2	2	2	
7	69P-42613-00-4D	.MOLDING, AIR DUCT .MANCHON A AIR	1	1	1	1	
8	90179-06M24	.NUT .ECROU	4	4	4	4	
9	90480-14M14	.GROMMET .PASSE-FIL	1	1	1	1	
10	61N-42628-00	.SEAL .JOINT	1	1	1	1	
11	61R-W0070-10	.GRAPHIC SET .JEU DIEMBLEMES	1	1	1	1	
12	695-42677-C0	.GRAPHIC, FRONT .ADHESIF, AVANT	1				
	69R-42677-00	.GRAPHIC, FRONT .ADHESIF, AVANT	1		1		FOR VOLGA
	69S-42677-00	.GRAPHIC, FRONT .ADHESIF, AVANT		1		1	FOR VOLGA
13	61R-42678-10	.GRAPHIC, REAR .ADHESIF, ARRIERE	1			1	
	61T-42678-10	.GRAPHIC, REAR .ADHESIF, ARRIERE		1		1	
14	6E0-44191-11	.INDICATOR, SHIFT .ETIQUETTE, EMBRAYAGE	1	1	1	1	

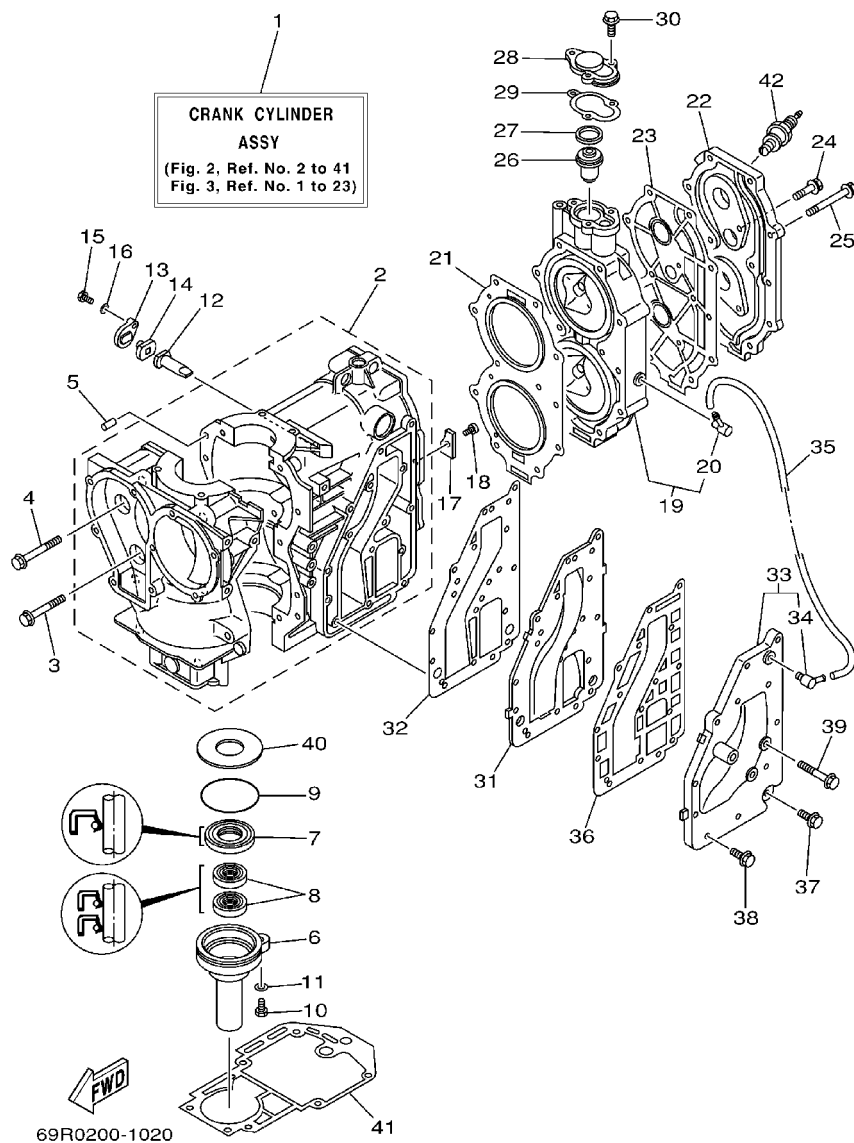

FIG. 2 CYLINDER. CRANKCASE CYLINDRE. CARTER

REF. NO.	PART NO. NO. PIECES	DESCRIPTION DESCRIPTION	25MH	30MH	25WC	30WC	REMARKS REMARQUES
1	69P-W0090-00-1S	CRANK CYLINDER ASSY EMBIELLAGE CYLINDRE (ENS.)	1		1		
	69S-W0090-00-1S	CRANK CYLINDER ASSY EMBIELLAGE CYLINDRE (ENS.)		1		1	
2	69P-15100-00-1S	CRANKCASE ASSY CARTER DE MOTEUR COMPLET	1	1	1	1	
3	90119-08009	BOLT, WITH WASHER BOULON, AVEC RONDELLE	2	2	2	2	
4	90119-08M65	BOLT, WITH WASHER BOULON, AVEC RONDELLE	8	8	8	8	
5	93606-12019	PIN, DOWEL GOUJON	2	2	2	2	
6	689-15396-01-5B	HOUSING, OIL SEAL LOGEMENT DE JOINT SPY	1	1	1	1	
7	93102-25008	OIL SEAL JOINT SPY	1	1	1	1	
8	93101-16001	OIL SEAL JOINT SPY	2	2	2	2	
9	93210-58M21	O-RING JOINT TORIQUE	1	1	1	1	
10	97095-06022	BOLT BOULON	1	1	1	1	
11	92995-06600	WASHER RONDELLE	1	1	1	1	
12	6J8-11325-00	ANODE ANODE	1	1	1	1	
13	6H3-11327-00-1S	COVER, ANODE COUVERCLE	1	1	1	1	
14	6H3-11328-00	GROMMET, ANODE PASSE-FIL	1	1	1	1	
15	97013-06016	BOLT BOULON	1	1	1	1	
16	92903-06600	WASHER, PLATE RONDELLE, PLATE	1	1	1	1	
17	689-11325-00	ANODE ANODE	1	1	1	1	
18	90151-06M02	SCREW, COUNTERSUNK VIS, TETE NOYEE	1	1	1	1	
19	61N-11111-01-1S	HEAD, CYLINDER 1 CULASSE	1		1		
	61T-11111-01-1S	HEAD, CYLINDER 1 CULASSE		1		1	
20	676-11372-00	.NIPPLE, HOSE .RACCORD, TUYAU	1	1	1	1	
21	61N-11181-A1	GASKET, CYLINDER HEAD 1 JOINT, DE CULASSE 1	1	1	1	1	
22	61N-11191-01-1S	COVER, CYLINDER HEAD 1 COUVERCLE, CULASSE 1	1	1	1	1	
23	61T-11193-A1	GASKET, HEAD COVER 1 JOINT, COUVERCLE DE CULASSE 1	1	1	1	1	
24	90119-06MA2	BOLT, WITH WASHER BOULON, AVEC RONDELLE	2	2	2	2	
25	90119-08015	BOLT, WITH WASHER BOULON, AVEC RONDELLE	11	11	11	11	

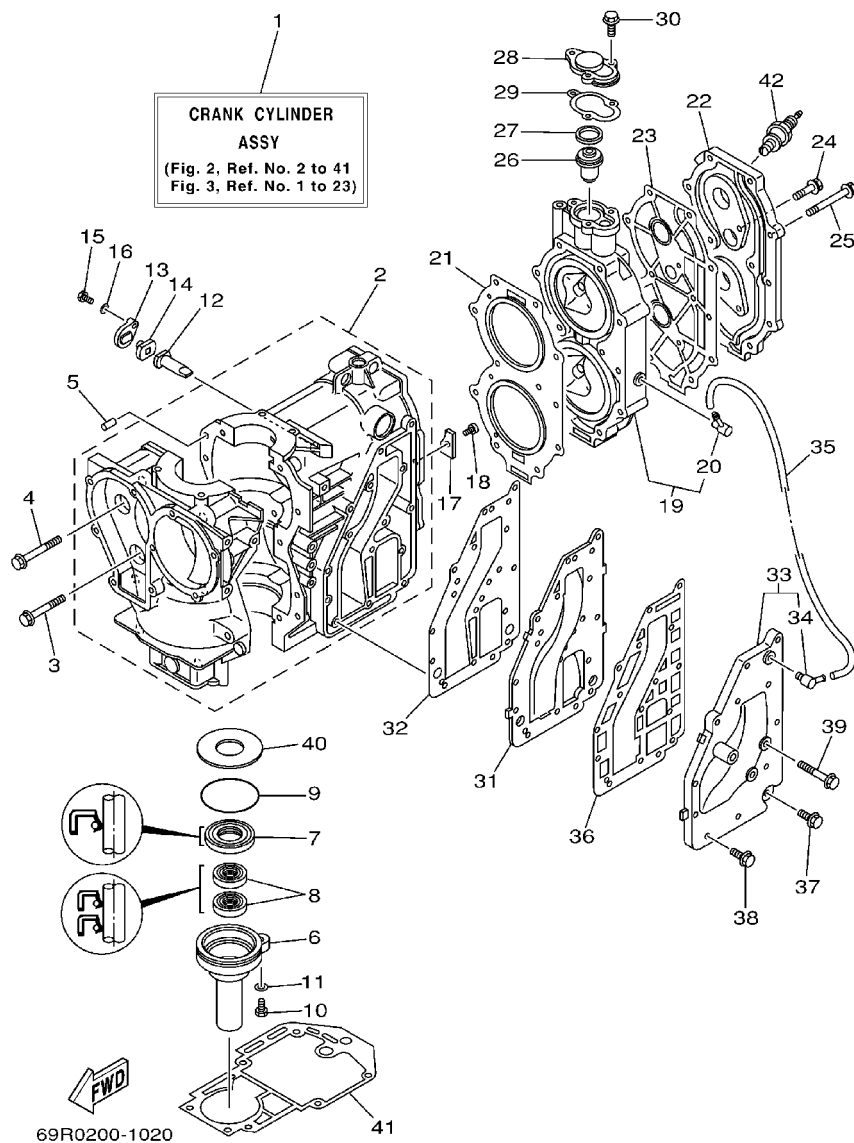
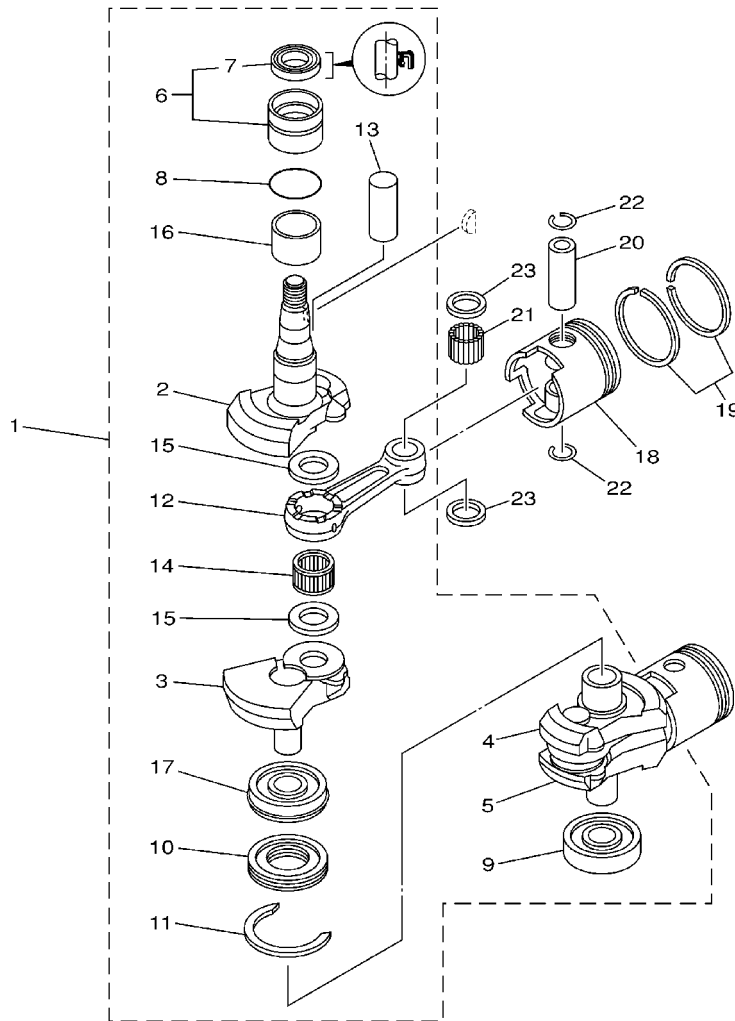

FIG. 2 CYLINDER. CRANKCASE CYLINDRE. CARTER

REF. NO.	PART NO. NO. PIECES	DESCRIPTION DESCRIPTION	25MH	30MH	25WC	30WC	REMARKS REMARQUES
26	6E5-12411-01	THERMOSTAT THERMOSTAT	1	1	1	1	
27	90201-21567	WASHER, PLATE RONDELLE, PLATE	1	1	1	1	
28	655-12413-01-1S	COVER, THERMOSTAT COUVERCLE, THERMOSTAT	1	1	1	1	
29	655-12414-A1	GASKET, COVER JOINT, COUVERCLE	1	1	1	1	
30	90119-06MA2	BOLT, WITH WASHER BOULON, AVEC RONDELLE	3	3	3	3	
31	6K8-41121-00-1S	INNER COVER, EXHAUST PLAQUE, ECHAPPEMENT	1	1	1	1	
32	6K8-41122-A1	GASKET, EXHAUST INNER COVER JOINT, PLAQUE D'EHAPPEMENT	1	1	1	1	
33	61N-41123-00-1S	OUTER COVER, EXHAUST COUVERCLE, ECHAPPEMENT	1	1	1	1	
34	676-11372-00	.NIPPLE, HOSE .RACCORD, TUYAU	1	1	1	1	
35	90445-10M41	HOSE (L105) DURITE (L105)	1	1	1	1	
36	6K8-41124-A1	GASKET, EXHAUST OUTER COVER JOINT, COUVERCLE D'ECHAPPEMENT	1	1	1	1	
37	90119-06MA3	BOLT, WITH WASHER BOULON, AVEC RONDELLE	1	1	1	1	
38	90119-06MA4	BOLT, WITH WASHER BOULON, AVEC RONDELLE	11	11	11	11	
39	90119-06MA0	BOLT, WITH WASHER BOULON, AVEC RONDELLE	3	3	3	3	
40	90201-50306	WASHER, PLATE RONDELLE, PLATE	1	1	1	1	
41	689-45113-A1	GASKET, UPPER CASING JOINT, TUBE D'ARBRE	1	1	1	1	
42	94702-00271	PLUG, SPARK (NGK BR7HS-10) BOUGIE D'ALLUMAGE (NGK BR7HS-10)	2				FOR VOLGA
	94702-00217	PLUG, SPARK (NGK B7HS-10) BOUGIE D'ALLUMAGE (NGK B7HS-10)	2		2		FOR VOLGA
	94702-00160	PLUG, SPARK (NGK B8HS-10) BOUGIE D'ALLUMAGE (NGK B8HS-10)			2	2	FOR VOLGA

FIG. 3 CRANKSHAFT. PISTON

VILEBREQUIN. PISTON



69R0010-1030

REF. NO.	PART NO. NO. PIECES	DESCRIPTION DESCRIPTION	25MH	30MH	25WC	30WC	REMARKS REMARQUES
1	69P-11400-00	CRANKSHAFT ASSY VILEBREQUIN COMPLET	1	1	1	1	
2	69P-11412-00	.CRANK 1 .MASSOLOTTE DE VILEBREQUIN 1	1	1	1	1	
3	61N-11422-00	.CRANK 2 .MASSOLOTTE DE VILEBREQUIN 2	1	1	1	1	
4	61N-11432-00	.CRANK 3 .MASSOLOTTE DE VILEBREQUIN 3	1	1	1	1	
5	61N-11442-00	.CRANK 4 .MASSOLOTTE DE VILEBREQUIN 4	1	1	1	1	
6	93399-99951	.BEARING .ROULEMENT	1	1	1	1	
7	93102-32M07	..OIL SEAL ..JOINT SPY	1	1	1	1	
8	93210-46M16	.O-RING .JOINT TORIQUE	1	1	1	1	
9	93306-305U3	.BEARING .ROULEMENT	1	1	1	1	
10	61N-11515-00	.SEAL, LABYRINTH 1 .JOINT, LABYRINTHE 1	1	1	1	1	
11	93440-62057	.CIRCLIP .CIRCLIP, TYPE S	1	1	1	1	
12	689-11651-00	.ROD, CONNECTING .BIELLE NUE	2	2	2	2	
13	689-11681-01	.PIN, CRANK 1 .MANETON, VILEBREQUIN 1	2	2	2	2	
14	93310-62406	.BEARING .ROULEMENT	2	2	2	2	
15	90209-24M03	.WASHER .RONDELLE	4	4	4	4	
16	90387-32002	.COLLAR .COLLERETTE	1	1	1	1	
17	93390-00009	.BEARING .ROULEMENT	1	1	1	1	
18	61N-11631-00-95	PISTON (STD) PISTON (STD)	2	2	2	2	
	61N-11635-00	PISTON (0.25MM O/S)	2	2	2	2	AP
	61N-11636-00	PISTON (0.50MM O/S)	2	2	2	2	AP
	61N-11636-00	PISTON (0.50MM O/S)	2	2	2	2	AP
	61N-11636-00	PISTON (0.50MM O/S)	2	2	2	2	AP
19	61N-11603-00	PISTON RING SET (STD) JUE DE SEGMENTS (STD)	2	2	2	2	
	61N-11604-00	PISTON RING SET (0.25MM O/S) JUE DE SEGMENTS (0.25MM O/S)	2	2	2	2	AP
	61N-11605-00	PISTON RING SET (0.50MM O/S) JUE DE SEGMENTS (0.50MM O/S)	2	2	2	2	AP
20	689-11633-00	PIN, PISTON AXE, PISTON	2	2	2	2	
21	93602-20M02	PIN, DOWEL GOUJON	68	68	68	68	
22	688-11634-00	CLIP, PISTON PIN AGRAFE, AXE DE PISTON	4	4	4	4	
23	90201-20M27	WASHER, PLATE RONDELLE, PLATE	4	4	4	4	

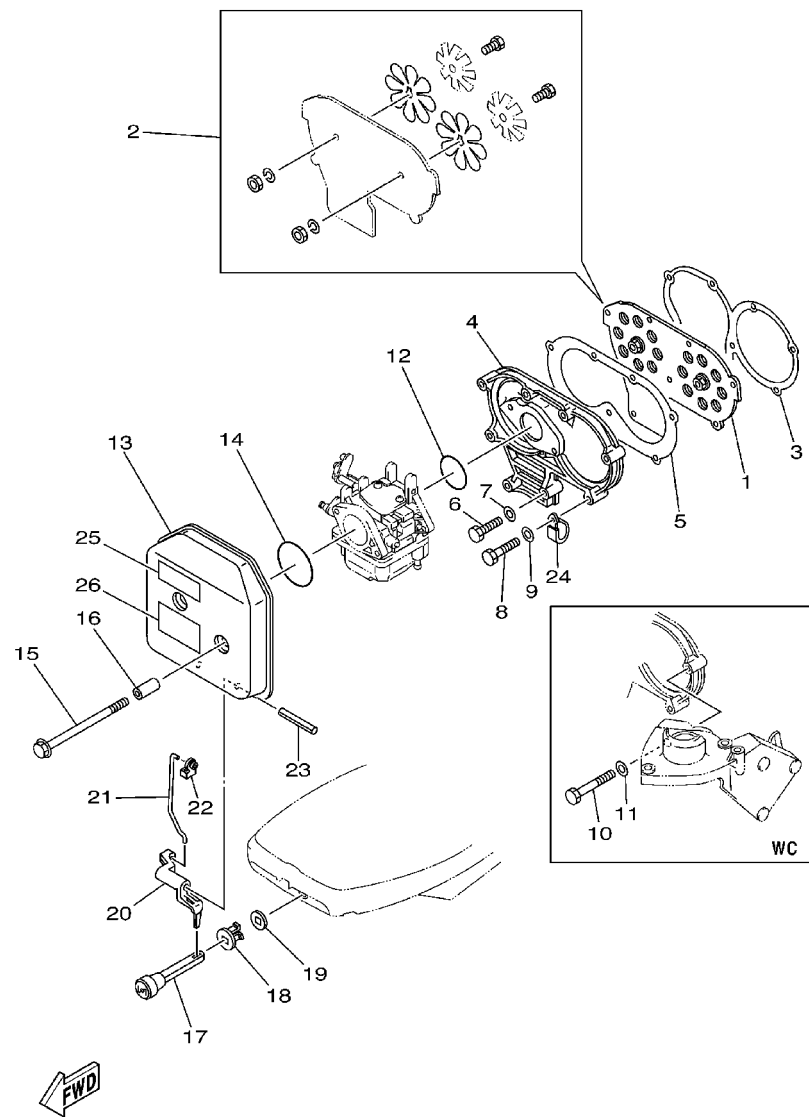

69R2300-2040

FIG. 4 INTAKE

ADMISSION

REF. NO.	PART NO. NO. PIECES	DESCRIPTION DESCRIPTION	ADMISSION				REMARKS REMARQUES
			25MH	30MH	25WC	30WC	
1	61N-13610-00	REED VALVE ASSY CLAPET COMPLET	1		1		
	689-13610-01	REED VALVE ASSY CLAPET COMPLET		1		1	
2	689-W0004-00	.REED SET .JEU DE CLAPETS	1	1	1	1	
3	648-13621-A1	GASKET, VALVE SEAT JOINT, SIEGE DE CLAPET	1	1	1	1	
4	61N-13641-01-1S	MANIFOLD 1 TUBULURE 1	1	1	1	1	
5	648-13645-A0	GASKET, MANIFOLD 1 JOINT, TUBULURE 1	1	1	1	1	
6	97013-06025	BOLT BOULON	2	2	2	2	FOR VOLGA
7	92903-06600	WASHER, PLATE RONDELLE, PLATE	2	2	2	2	FOR VOLGA
8	97013-06035	BOLT BOULON	7	7			FOR VOLGA
	97013-06035	BOLT BOULON			6	6	
9	92903-06600	WASHER, PLATE RONDELLE, PLATE	7	7			FOR VOLGA
	92903-06600	WASHER, PLATE RONDELLE, PLATE			6	6	
10	97013-06050	BOLT BOULON			1	1	
11	92903-06600	WASHER, PLATE RONDELLE, PLATE			1	1	
12	61N-14198-00	GASKET JOINT	1	1	1	1	
13	61N-14440-00	SILENCER ASSY, INTAKE SIENCIEUX D'ADMISSION	1	1	1	1	
14	93210-40659	O-RING JOINT TORIQUE	1	1	1	1	
15	90119-06M94	BOLT, WITH WASHER BOULON, AVEC RONDELLE	2	2	2	2	
16	90387-06M26	COLLAR COLLERETTE	2	2	2	2	
17	682-41271-00	KNOB, CHOKE BOUTON DE STARTER	1	1	1	1	
18	689-41273-00	GROMMET PASSE-FIL	1	1	1	1	
19	6J8-41274-00	GROMMET 2 PASSE-FIL 2	1	1	1	1	
20	689-41252-01	LEVER, CHOKE 1 LEVIER 1	1	1	1	1	
21	61N-41256-00	ROD, CHOKE 1 TRINGLE 1, STARTER	1	1	1	1	
22	661-41262-02	JOINT, CHOKE LEVER RACCORD, LEVIER DE STARTER	1	1	1	1	
23	91690-40048	PIN, SPRING GOUPILLE, ELASTIQUE	1	1	1	1	
24	90465-06M88	CLAMP BRIDE	1	1	1	1	

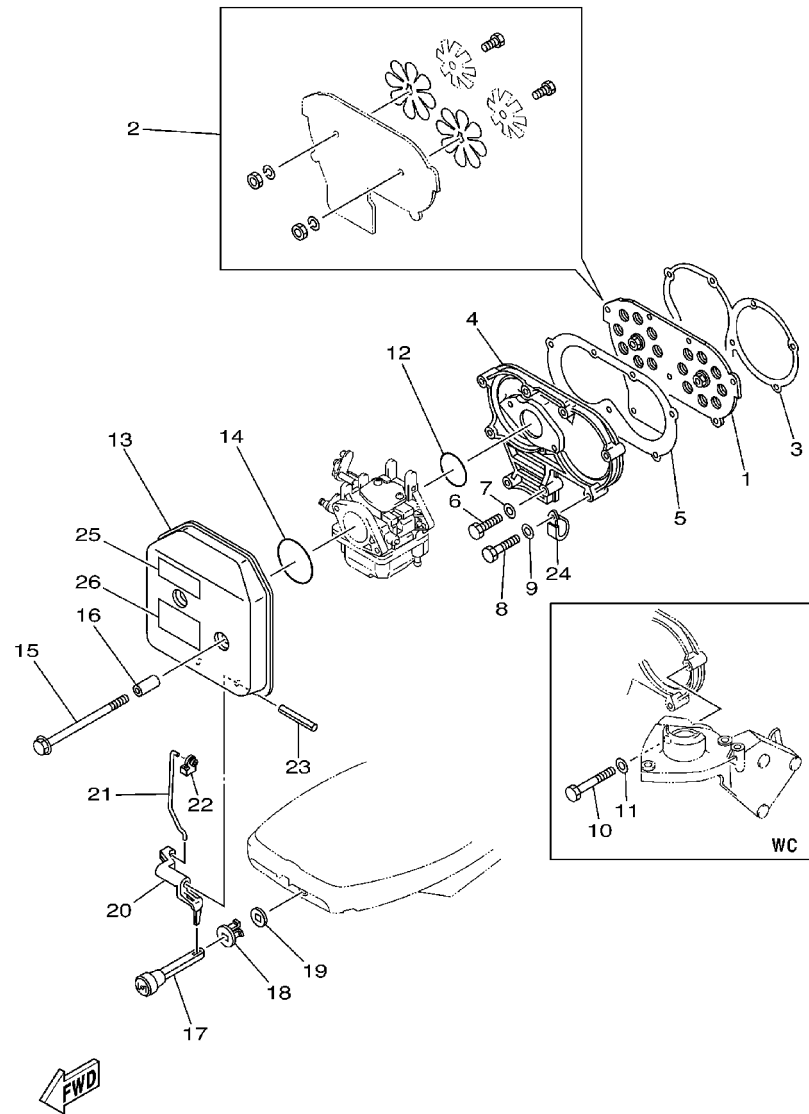

69R2300-2040

FIG. 4 INTAKE

ADMISSION

REF. NO.	PART NO. NO. PIECES	DESCRIPTION DESCRIPTION	25MH	30MH	25WC	30WC	REMARKS REMARQUES
25	6A1-83625-41	MARK 5 ETIQUETTE 5	1	1	1	1	FOR VOLGA
26	6A1-83625-51	MARK 5 ETIQUETTE 5	1				
	61T-83625-80	MARK 5 ETIQUETTE 5	1	1	1	1	

FIG. 5 CARBURETOR

CARBURETEUR

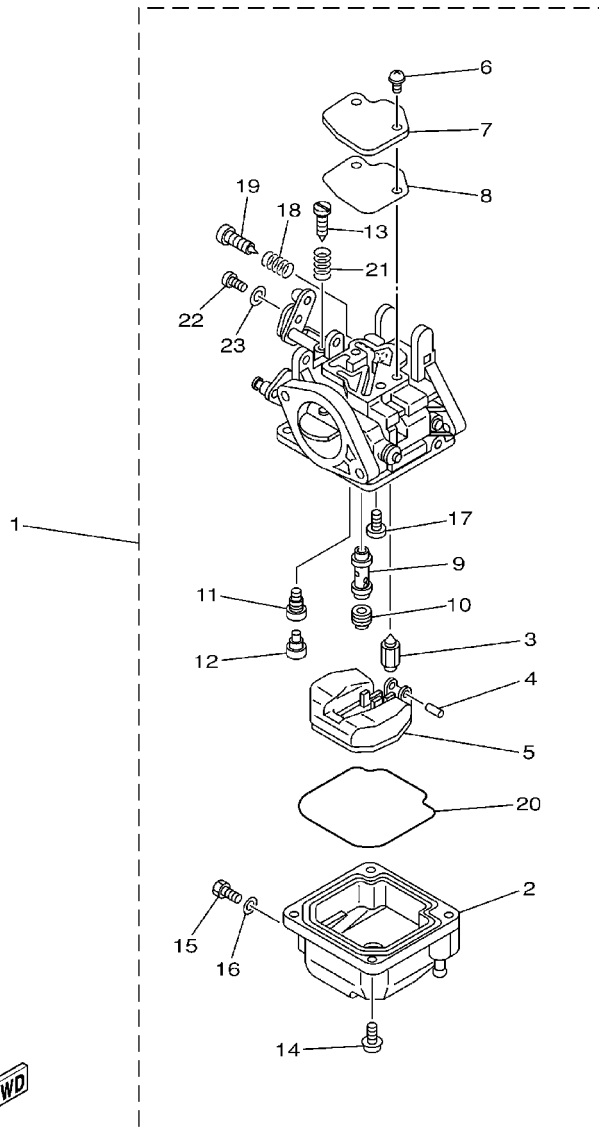

69R0010-1050

REF. NO.	PART NO. NO. PIECES	DESCRIPTION DESCRIPTION	25MH	30MH	25WC	30WC	REMARKS REMARQUES
1	69P-14301-00	CARBURETOR ASSY 1 CARBURATEUR COMPLET 1	1		1		
	69S-14301-00	CARBURETOR ASSY 1 CARBURATEUR COMPLET 1		1		1	
2	61N-14381-00	.BODY, FLOAT CHAMBER .CORPS, CUVE DE FLOTTEUR	1	1	1	1	
3	61N-14392-00	.VALVE, NEEDLE .POINTEAU	1	1	1	1	
4	6E5-14386-01	.PIN, FLOAT .AXE, FLOTTEUR	1	1	1	1	
5	6L2-14385-00	.FLOAT .FLOTTEUR	1	1	1	1	
6	97980-04110	.SCREW, WITH WASHER .VIS, AVEC RONDELLE	2	2	2	2	
7	6L2-14157-00	.COVER, MIXING .COUVERCLE DE CHAMBRE	1	1	1	1	
8	6L2-14399-00	.GASKET .JOINT	1	1	1	1	
9	61N-14341-00	.NOZZLE, MAIN .PUITS D'AIGUILLE	1		1		FOR 69P-14301-00
	61T-14341-00	.NOZZLE, MAIN .PUITS D'AIGUILLE		1		1	FOR 69S-14301-00
10	61N-14343-65	.JET, MAIN (#130) .GICLEUR, PRINCIPAL (#130)	1	1	1	1	
11	6L2-14342-34	.JET, PILOT (# 68) .GICLEUR, RALENTI (# 68)	1	1	1	1	
12	50M-14355-00	.PLUG .PLOT	1	1	1	1	
13	664-14321-01	.SCREW, THROTTLE .VIS, ACCELERATEUR	1	1	1	1	
14	97980-04112	.SCREW, WITH WASHER .VIS, AVEC RONDELLE	4	4	4	4	
15	677-14383-01	.SCREW, DRAIN .BOUCHON, PURGE	1	1	1	1	
16	6L2-14398-00	.GASKET .JOINT	1	1	1	1	
17	98980-04006	.SCREW, BIND .VIS, DE PRESSION	2	2	2	2	
18	646-14212-01	.SPRING, PILOT ADJUSTING .RESSORT, VIS DE RALENTI	1	1	1	1	
19	61N-14323-00	.SCREW, AIR ADJUSTING .VIS DE DOSEUR D'AIR	1	1	1	1	
20	6L2-14384-00	.GASKET, FLOAT CHAMBER .JOINT, CUVE DE FLOTTEUR	1	1	1	1	
21	61N-14212-00	.SPRING, PILOT ADJUSTING .RESSORT, VIS DE RALENTI	1	1	1	1	
22	97890-05006	.SCREW, PAN HEAD .VIS, TETE TRONCONIQUE	1	1	1	1	
23	62Y-14597-00	.WASHER .RONDELLE	1	1	1	1	

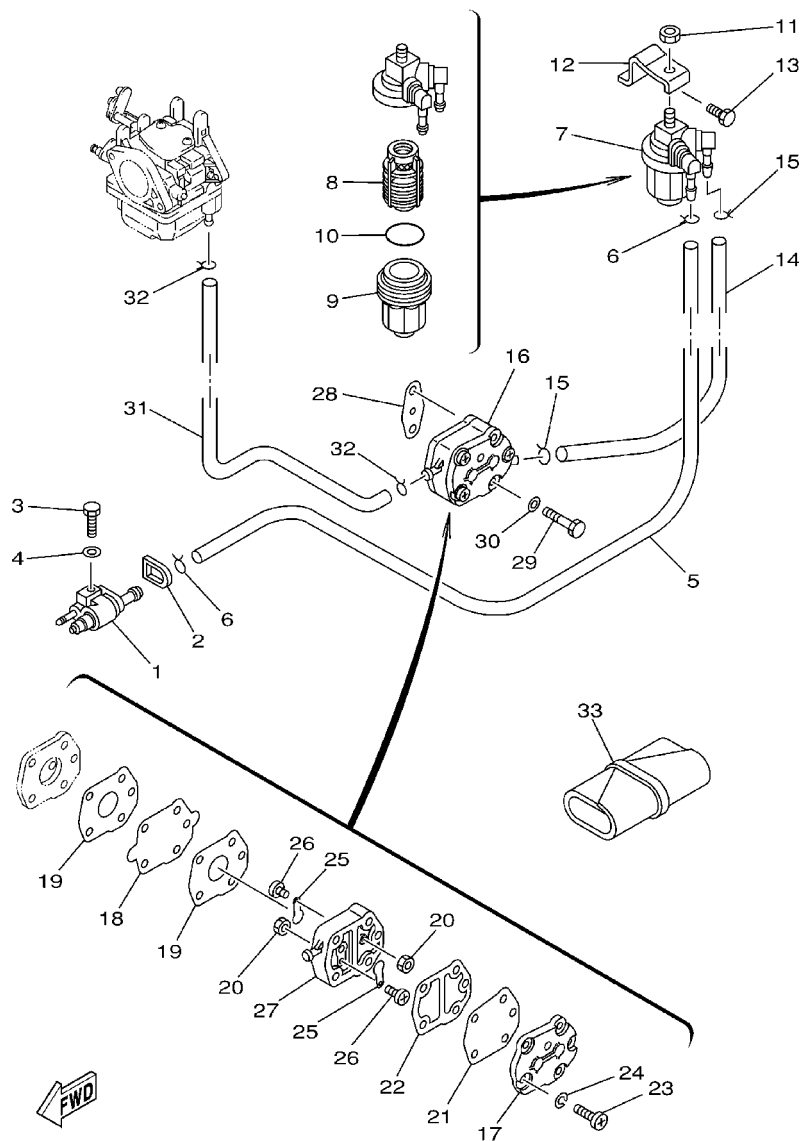

69R0010-1060

FIG. 6 FUEL

CARBURANT

REF. NO.	PART NO. NO. PIECES	DESCRIPTION DESCRIPTION	25MH	30MH	25WC	30WC	REMARKS REMARQUES
1	6G1-24304-02	FUEL PIPE JOINT COMP. 1 DURITE RACCORDEMT. A ESSENCE	1	1	1	1	
2	61N-24329-00	SEAL JOINT	1	1	1	1	
3	97095-06020	BOLT BOULON	1	1	1	1	
4	92995-06600	WASHER RONDELLE	1	1	1	1	
5	90445-09M75	HOSE (L370) DURITE (L370)	1	1	1	1	
6	90467-08004	CLIP JONC	2	2	2	2	
7	61N-24560-00	FILTER ASSY ENS FILTRE	1	1	1	1	
8	61N-24563-00	.ELEMENT, FILTER .ELEMENT, FILTRE	1	1	1	1	
9	61N-24521-00	.CUP, FILTER .CUVETTE, FILTRE	1	1	1	1	
10	93210-32738	.O-RING JOINT TORIQUE	1	1	1	1	
11	95380-08600	NUT ECROU	1	1	1	1	
12	61N-24566-01	BRACKET, FILTER SUPPORT, FILTRE	1	1	1	1	
13	97013-06014	BOLT BOULON	1	1	1	1	
14	689-24311-00	PIPE, FUEL 1 DURITE A ESSENCE	1	1	1	1	
15	90467-08004	CLIP JONC	2	2	2	2	
16	692-24410-00	FUEL PUMP ASSY POMPE A ESSENCE	1	1	1	1	
17	6A0-24413-00	.BODY 2 .CORPS 2	1	1	1	1	
18	692-24411-00	.DIAPHRAGM .DIAPHRAGME	1	1	1	1	
19	648-24434-01	.GASKET, BODY JOINT, CORPS	2	2	2	2	
20	95380-03600	NUT ECROU	2	2	2	2	
21	663-24411-00	.DIAPHRAGM .DIAPHRAGME	1	1	1	1	
22	648-24435-02	.GASKET, BODY 2 JOINT, CORPS 2	1	1	1	1	
23	98503-05028	.SCREW, PAN HEAD .VIS, TETE TRONCONIQUE	3	3	3	3	
24	92990-05100	.WASHER, SPRING .RONDELLE, GROWER	3	3	3	3	
25	6A0-24421-01	.VALVE, CHECK .SOUPAPE, RETENUE	2	2	2	2	
26	6A0-14325-00	.SCREW, PAN HEAD .VIS TETE CONIQUE	2	2	2	2	
27	6A0-24412-02	.BODY 1 .CORPS 1	1	1	1	1	

B4

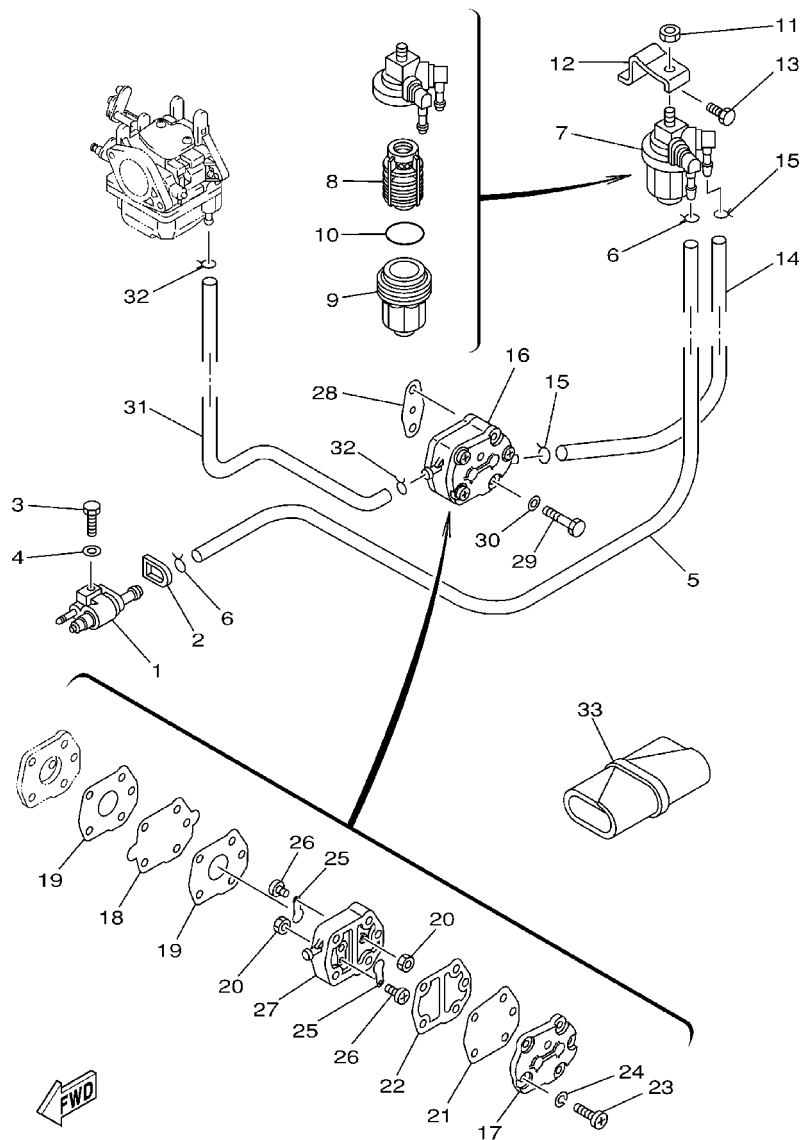

69R0010-1060

FIG. 6 FUEL

CARBURANT

REF. NO.	PART NO. NO. PIECES	DESCRIPTION DESCRIPTION	25MH	30MH	25WC	30WC	REMARKS REMARQUES
28	650-24431-A0	GASKET, FUEL PUMP 1 JOINT 1 DE POMPE A ESSENCE	1	1	1	1	
29	97095-06040	BOLT BOULON	2	2	2	2	
30	92995-06600	WASHER RONDELLE	2	2	2	2	
31	6A1-24311-00	PIPE, FUEL 1 DURITE A ESSENCE	1	1	1	1	
32	90467-08004	CLIP JONC	2	2	2	2	
33	656-W2810-02	TOOL KIT TROUSSE A OUTILS	1	1	1	1	
<hr/>							
<hr/>							
<hr/>							
<hr/>							
<hr/>							
<hr/>							
<hr/>							

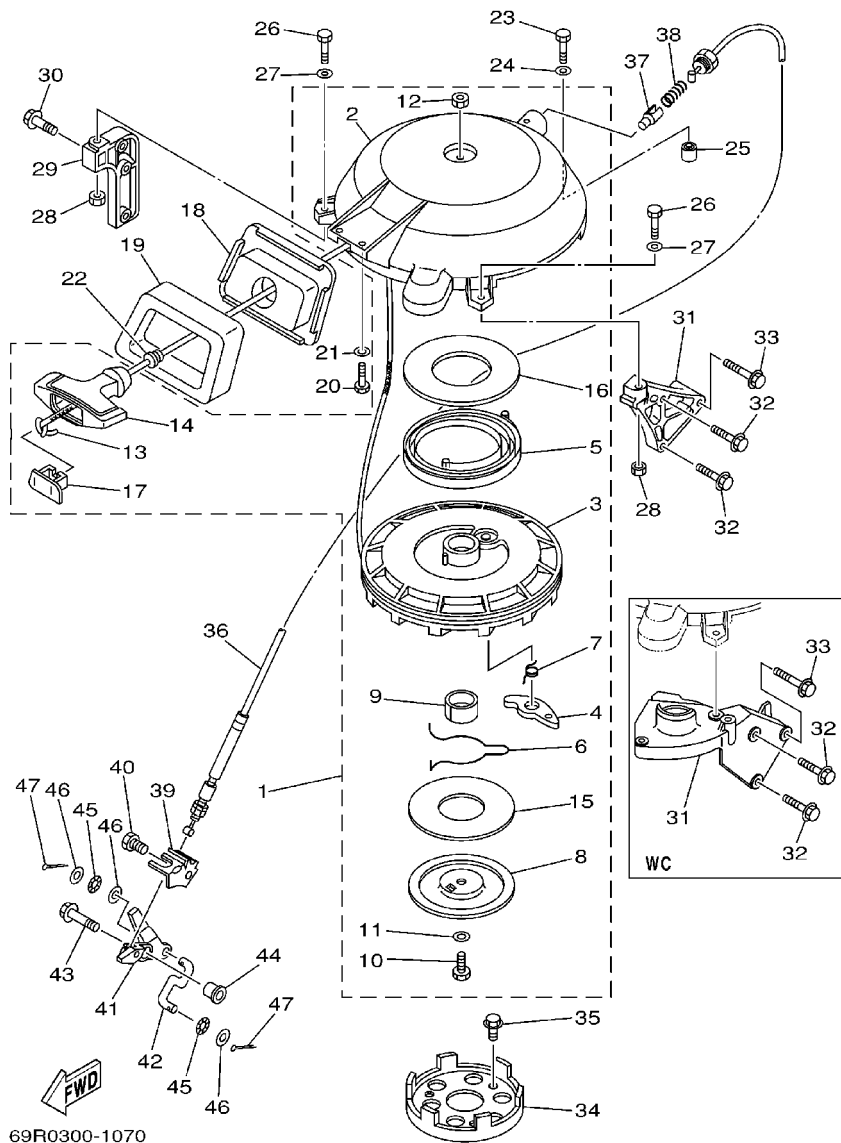

69R0300-1070

FIG. 7 STARTER

DEMARREUR

REF. NO.	PART NO. NO. PIECES	DESCRIPTION DESCRIPTION	25MH	30MH	25WC	30WC	REMARKS REMARQUES
1	61N-W1571-11	STARTER ASSY DEMARREUR COMPLET	1	1	1	1	
2	61N-15711-10	.CASE, STARTER .CARTER DE DEMARREUR	1	1	1	1	
3	6G0-15714-01	.DRUM, SHEAVE .TAMBOUR, POULIE	1	1	1	1	
4	6F5-15741-01	.PAWL, DRIVE .CLIQUET, ENTRAINEMENT	1	1	1	1	
5	6F5-15713-01	.SPRING, STARTER .RESSORT DE DEMARREUR	1	1	1	1	
6	61N-15715-00	.SPRING, FRICTION .RESSORT, PLAQUE D'ENTRAINEMT	1	1	1	1	
7	61N-15734-00	.SPRING, RETURN .RESSORT, RAPPEL	1	1	1	1	
8	6F5-15716-01	.PLATE, DRIVE .PLAQUE, ENTRAINEMENT	1	1	1	1	
9	6G0-15754-00	.BUSH 2 .BAGUE 2	1	1	1	1	
10	97313-08030	.BOLT .BOULON	1	1	1	1	
11	6F5-15726-01	.WASHER, FLAT .RONDELLE, PLATE	1	1	1	1	
12	95303-08700	.NUT .ECROU	1	1	1	1	
13	*	.WIRE (L:1900MM) .FIL (L:1900MM)	1	1	1	1	
14	689-15755-01	.HANDLE, STARTER .POIGNEE, DE DEMARREUR	1	1	1	1	
15	6F5-15764-00	.COLLAR 1 .COLLERETTE 1	1	1	1	1	
16	6F5-15739-00	.WASHER, THRUST .RONDELLE, DE BUTEE	1	1	1	1	
17	6F5-15779-02	.COVER .COUVERCLE	1	1	1	1	
18	61N-15758-01-4D	GUIDE, ROPE GUIDE DE CABLE	1	1	1	1	
19	61N-15762-00	SEAL, RUBBER 2 JOINT CAOUTCHOUC 2	1	1	1	1	
20	97095-06016	BOLT BOULON	2	2	2	2	
21	92995-06600	WASHER RONDELLE	2	2	2	2	
22	6A0-15789-00	DAMPER AMORTISSEUR	1	1	1	1	
23	97095-06035	BOLT BOULON	1	1	1	1	
24	92995-06600	WASHER RONDELLE	1	1	1	1	
25	99530-10014	PIN, DOWEL GOUJON, D'ASSEMBLAGE	1	1	1	1	
<p>* CUT FROM 50M ROLLS, PART NO. 90890-44373, CUTTING LENGTH 1.9M</p> <p>* A PRELEVER SUR BOBINE 50M , REFERENCE 90890-44373, LONGUEUR DE COUPE 1.9M</p>							

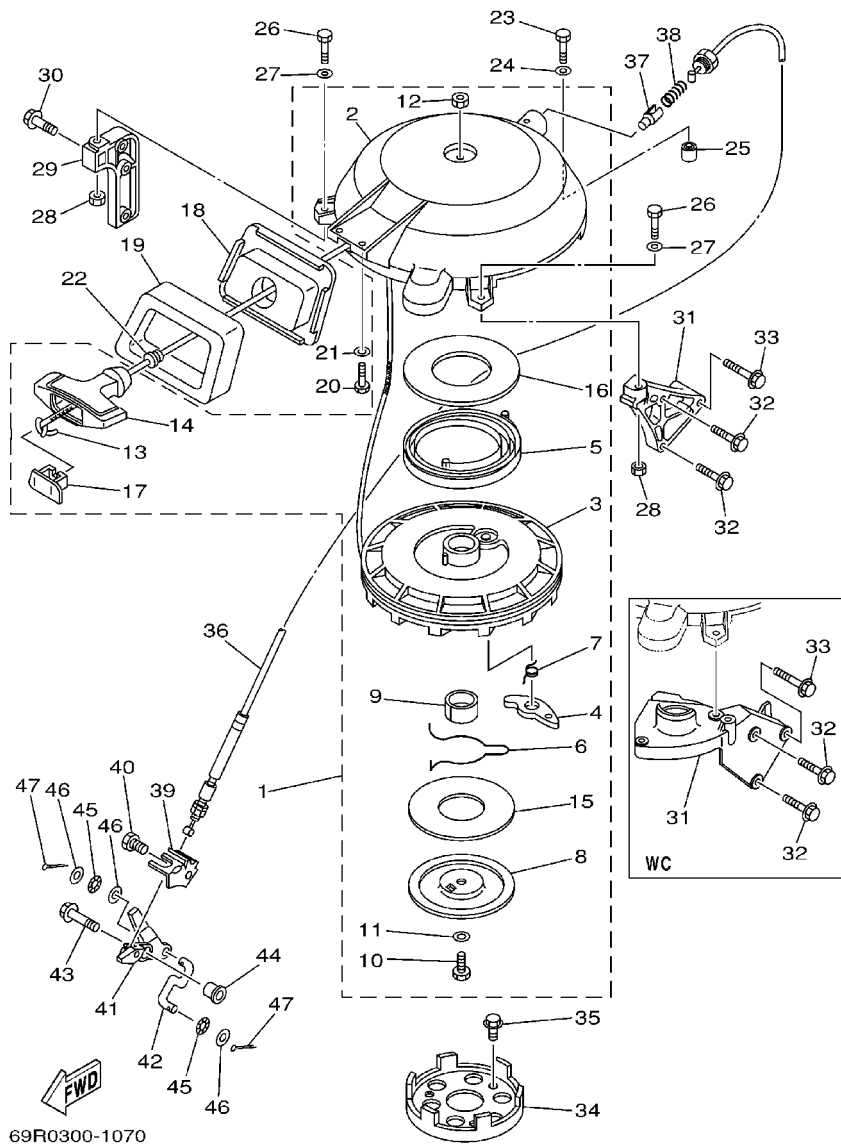

69R0300-1070

FIG. 7 STARTER

DEMARREUR

REF. NO.	PART NO. NO. PIECES	DESCRIPTION DESCRIPTION	25MH	30MH	25WC	30WC	REMARKS REMARQUES
26	97095-06035	BOLT BOULON	2	2	2	2	
27	92995-06600	WASHER RONDELLE	2	2	2	2	
28	95380-06600	NUT, HEXAGON ECROU	2	2			
	95380-06600	NUT, HEXAGON ECROU			1	1	
29	6H7-15771-01-94	STAY 1 SUPPORT 1	1	1	1	1	
30	90119-06MA3	BOLT, WITH WASHER BOULON, AVEC RONDELLE	2	2	2	2	
31	656-15772-00-94	STAY 2 SUPPORT 2	1	1			
	61T-15772-01-94	STAY 2 SUPPORT 2			1	1	
32	90119-06MA3	BOLT, WITH WASHER BOULON, AVEC RONDELLE	2	2			
	90119-06MA4	BOLT, WITH WASHER BOULON, AVEC RONDELLE			2	2	
33	90119-06025	BOLT, WITH WASHER BOULON, AVEC RONDELLE	1	1	1	1	
34	6F5-15723-01	PULLEY, STARTER POULIE DE DEMARREUR	1	1	1	1	
35	90105-08M10	BOLT, FLANGE BOULON	3	3	3	3	
36	61T-15770-00	CABLE COMP., STARTER STOP CABLE, BUTEE DE DEMAR	1	1	1	1	
37	656-15748-00	PLUNGER, STARTER STOP PLONGEUR, BUTEE DE DEMAR	1	1	1	1	
38	90501-10227	SPRING, COMPRESSION RESSORT, COMPRESSION	1	1	1	1	
39	69P-15774-00	STAY 4 SUPPORT 4	1	1	1	1	
40	97095-06010	BOLT BOULON	1	1	1	1	
41	69P-15746-00	ARM BRAS	1	1	1	1	
42	689-15747-70	LINK BIELLETTTE	1	1	1	1	
43	90119-06M23	BOLT, WITH WASHER BOULON, AVEC RONDELLE	1	1	1	1	
44	90387-06013	COLLAR COLLERETTE	1	1	1	1	
45	90206-05005	WASHER, WAVE RONDELLE, ONDULEE	2	2	2	2	
46	92903-05600	WASHER, PLATE RONDELLE, PLATE	3	3	3	3	
47	91490-16010	PIN, COTTER GOUPILLE, FENDUE	2	2	2	2	

FIG. 8 GENERATOR

GENERATRICE

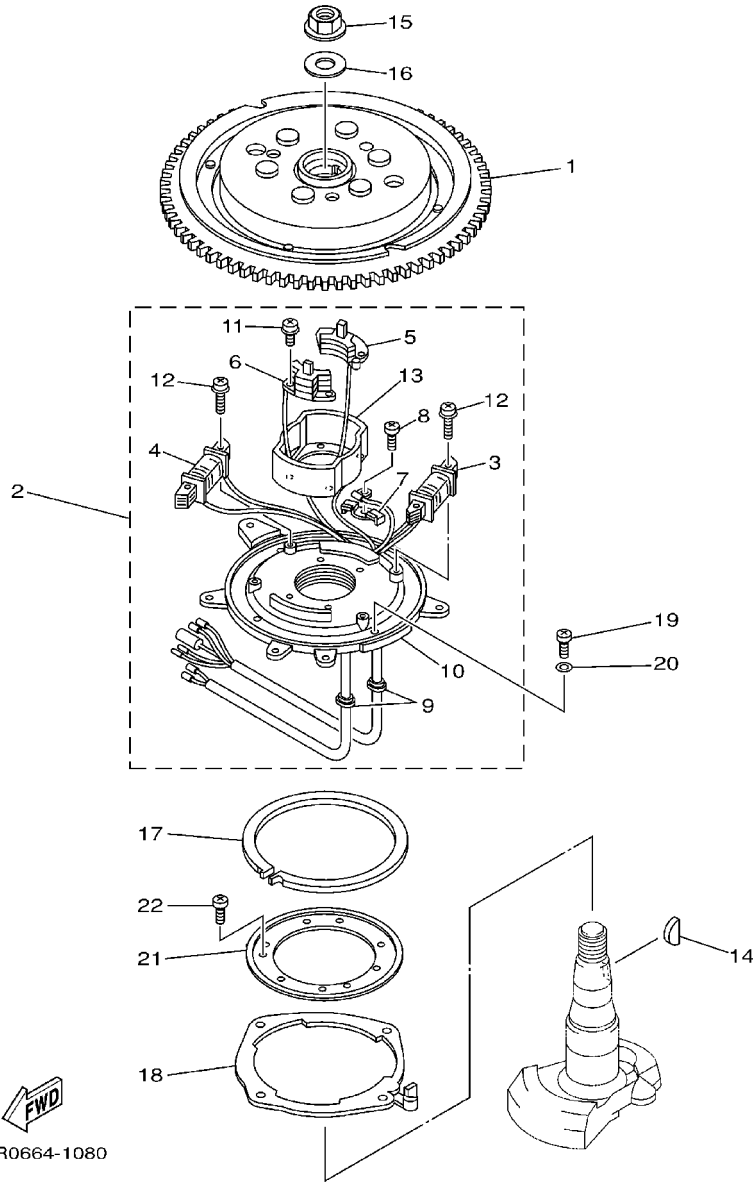

69R0664-1080

REF. NO.	PART NO. NO. PIECES	DESCRIPTION DESCRIPTION	25MH	30MH	25WC	30WC	REMARKS REMARQUES
1	61T-85550-10	ROTOR ASSY ROTOR CPLT	1		1	1	"WC"-FOR VOLGA
	61N-85550-10	ROTOR ASSY ROTOR CPLT	1	1			FOR VOLGA
2	69P-85560-00	BASE ASSY ENS. FLASQUE	1	1	1	1	
3	69P-85541-09	.COIL, CHARGE .BOBINE, CHARGE	1	1	1	1	
4	61N-81313-09	.COIL, LIGHTING 1 .BOBINE, ECLAIRAGE 1	1	1	1	1	
5	61N-85543-09	.COIL, PULSER .BOBINE, PULSEUR	1	1	1	1	
6	61N-85543-19	.COIL, PULSER .BOBINE, PULSEUR	1	1	1	1	
7	6E9-81328-70	.CLAMP .COLLIER	1	1	1	1	
8	97802-04006	.SCREW, PAN HEAD .VIS, TETE TRONCONIQUE	1	1	1	1	
9	6E9-85516-70	.GROMMET .ENTRETOISE	2	2	2	2	
10	69P-85561-00	.BASE, MAGNETO .BASE, MAGNETO	1	1	1	1	
11	97607-04112	.SCREW, PAN HEAD WITH WASHER .VIS HEXAGONAL	4	4	4	4	
12	97607-06125	.SCREW, PAN HEAD WITH WASHER .VIS HEXAGONAL	4	4	4	4	
13	61N-85537-00	.COVER .COUVERCLE	1	1	1	1	
14	90280-05015	KEY, WOODRUFF CLAVETTE, DEMI-LUNE	1	1	1	1	
15	90179-16M05	NUT ECROU	1	1	1	1	
16	90201-16M44	WASHER, PLATE RONDELLE, PLATE	1	1	1	1	
17	676-41611-00	RETAINER, MAGNETO BASE FLASQUE, PATEAU D'AVANCE	1	1	1	1	
18	676-41613-00	PLATE, BASE FRICTION PLAQUE, FRICTION DE BASE	1	1	1	1	
19	97880-05012	SCREW, PAN HEAD VIS, TETE TRONCONIQUE	4	4	4	4	
20	92990-05600	WASHER, PLATE RONDELLE, PLATE	4	4	4	4	
21	689-41612-01	RETAINER, MAGNETO BASE FLASQUE, PATEAU D'AVANCE	1	1	1	1	
22	97880-06010	SCREW, PAN HEAD VIS, TETE TRONCONIQUE	4	4	4	4	

FIG. 9 ELECTRICAL 1

PARTIE ELECTRIQUE 1

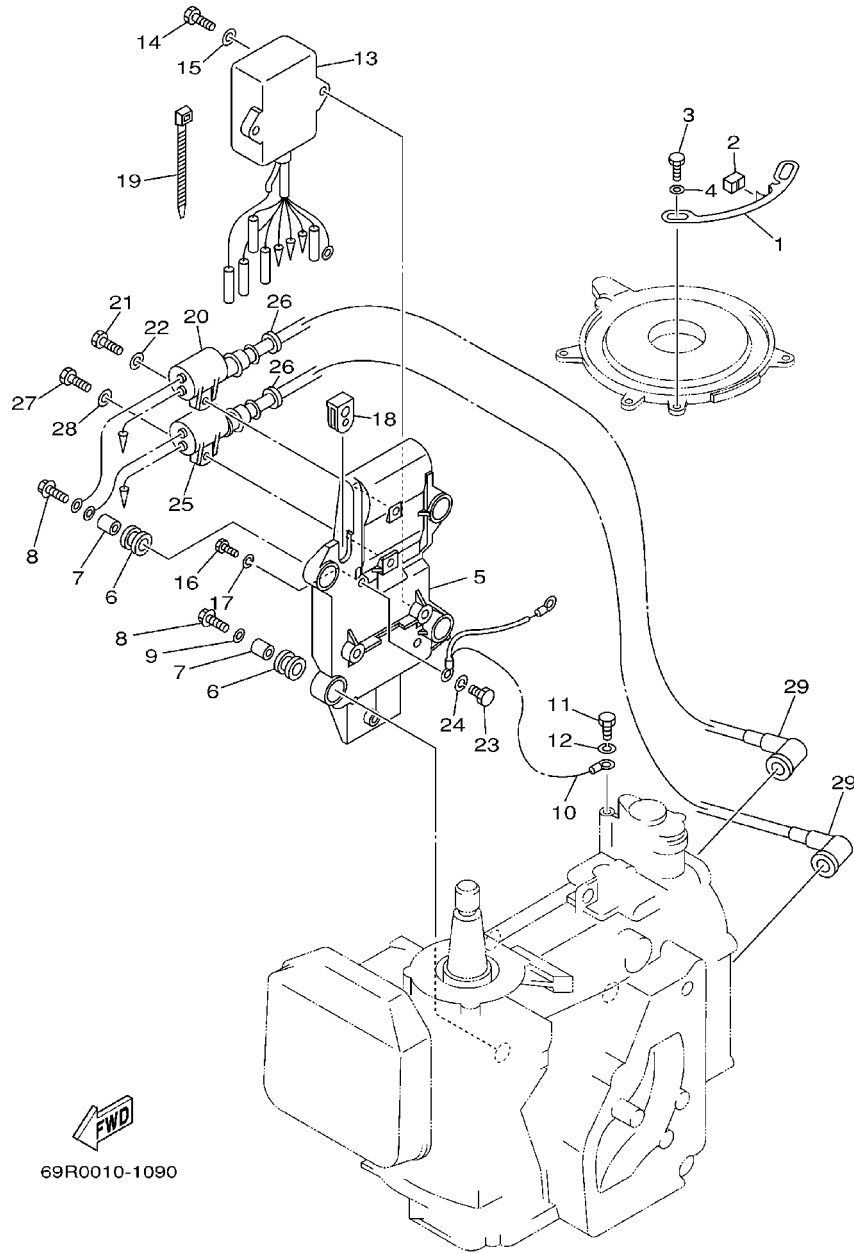

69R0010-1090

REF. NO.	PART NO. NO. PIECES	DESCRIPTION DESCRIPTION	25MH	30MH	25WC	30WC	REMARKS REMARQUES
1	61N-41615-00	STOPPER, MAGNETO BASE BUTEE, PLATEAU D'AVANCE	1	1	1	1	
2	61N-44194-01	CAP CAPUCHON	1		1		
	61T-44194-01	CAP CAPUCHON		1		1	
3	97095-06010	BOLT BOULON	2	2	2	2	
4	92995-06600	WASHER WASH RONDELLE	2	2	2	2	
5	61N-85542-00-94	BRACKET SUPPORT	1	1	1	1	
6	61N-82317-00	DAMPER, IGNITION COIL AMORTISSEUR, BOBINE D'ALLUM	4	4	4	4	
7	624-42542-00	PIPE TUYAU	4	4	4	4	
8	90119-06M95	BOLT, WITH WASHER BOULON, AVEC RONDELLE	4	4	4	4	
9	90201-06M30	WASHER, PLATE RONDELLE, PLATE	2	2	2	2	
10	61N-82519-01	WIRE, EARTH LEAD FIL, MASSE	1	1	1	1	
11	97090-06012	BOLT BOULON	1	1	1	1	
12	92990-06100	WASHER, SPRING RONDELLE, GROWER	1	1	1	1	
13	61N-85540-13	C.D.I. UNIT ASSY BLOC C.D.I.	1	1	1	1	
14	97095-06020	BOLT BOULON	2	2	2	2	
15	92995-06600	WASHER WASH RONDELLE	2	2	2	2	
16	97090-06012	BOLT BOULON	1	1	1	1	
17	92990-06100	WASHER, SPRING RONDELLE, GROWER	1	1	1	1	
18	6H3-81922-00	GROMMET OEILLET CAOUTCHOUC	1	1	1	1	
19	90465-13M11	CLAMP BRIDE	1	1	1	1	
20	6H5-85570-00	IGNITION COIL ASSY BOBINE D'ALLUMAGE (ENS.)	1				FOR VOLGA
	61N-85570-00	IGNITION COIL ASSY BOBINE D'ALLUMAGE (ENS.)	1	1	1	1	
21	97095-06020	BOLT BOULON	1	1	1	1	
22	92995-06600	WASHER WASH RONDELLE	1	1	1	1	
23	97090-06012	BOLT BOULON	1	1	1	1	
24	92990-06100	WASHER, SPRING RONDELLE, GROWER	1	1	1	1	
25	61N-85570-00	IGNITION COIL ASSY BOBINE D'ALLUMAGE (ENS.)	1				

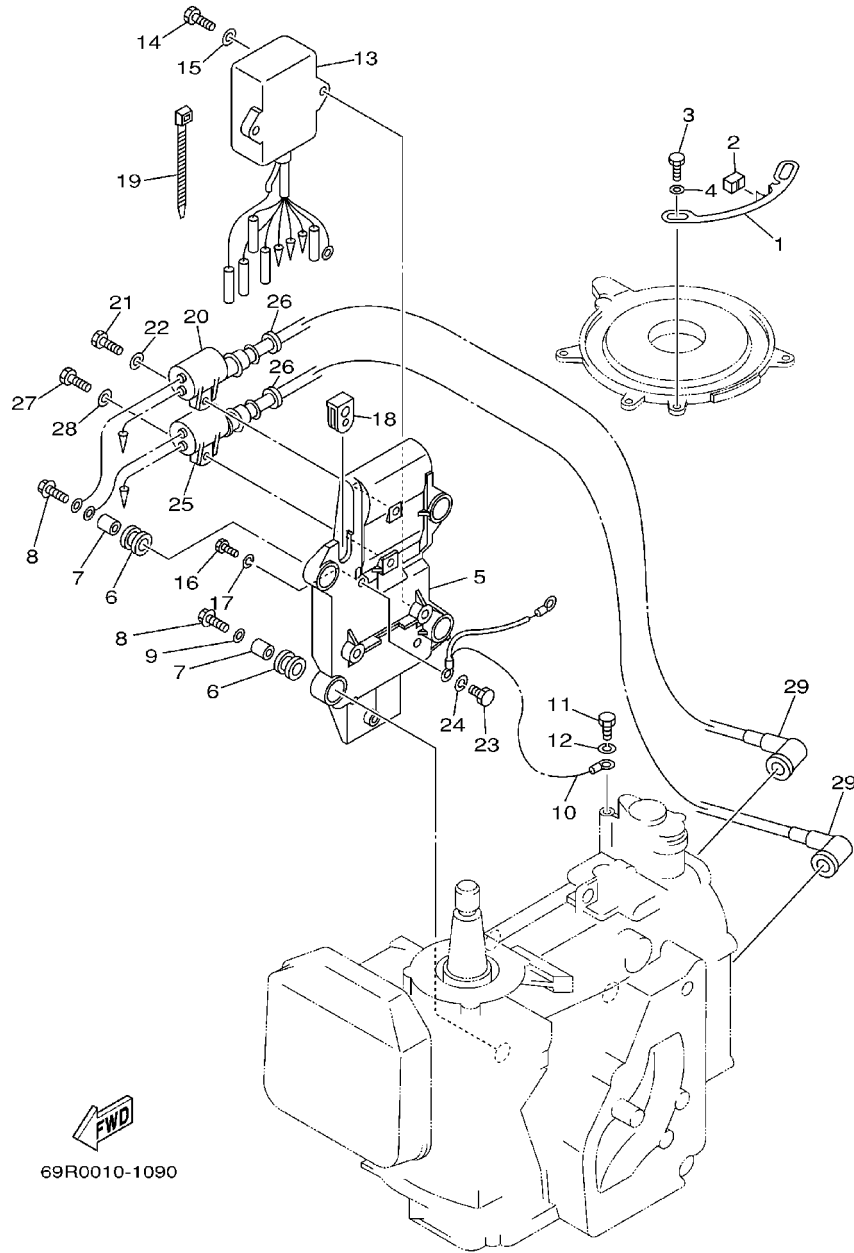

FIG. 9 ELECTRICAL 1

PARTIE ELECTRIQUE 1

REF. NO.	PART NO. NO. PIECES	DESCRIPTION DESCRIPTION	25MH	30MH	25WC	30WC	REMARKS REMARQUES
25	61N-85570-10	IGNITION COIL ASSY BOBINE D'ALLUMAGE (ENS.)	1	1	1	1	FOR VOLGA
26	90480-25161	GROMMET PASSE-FIL	2	2	2	2	
27	97095-06020	BOLT BOULON	1	1	1	1	
28	92995-06600	WASHER RONDELLE	1	1	1	1	
29	6G1-82370-21	PLUG CAP ASSY ANTIPARASITE	2				
	663-82370-01	PLUG CAP ASSY ANTIPARASITE	2	2	2	2	FOR VOLGA

FWD
69R0010-1090

FIG. 10 ELECTRICAL 2

PARTIE ELECTRIQUE 2

REF. NO.	PART NO. NO. PIECES	DESCRIPTION DESCRIPTION	25MH	30MH	25WC	30WC	REMARKS REMARQUES
1	6J8-81960-00	RECTIFIER & REGULATOR ASSY REDRESSEUR REGULATEUR CPLT	1				EXCEPT FOR VOLGA
2	69R-81915-00	PLATE, REGULATOR FITTING PLAQUE, FIXATION DE REGULATEUR	1				EXCEPT FOR VOLGA
3	90387-06504	COLLAR COLLERETTE	2				EXCEPT FOR VOLGA
4	6E5-82582-00	COVER, WIRE HARNESS COUVERCLE, FAISCEAU DE FILS	1				EXCEPT FOR VOLGA
5	69R-82553-00	EXTENSION, WIRE LEAD EXTENSION, FAISCEAU	1				EXCEPT FOR VOLGA
6	90464-08M07	CLAMP BRIDE	1				EXCEPT FOR VOLGA
7	90119-06026	BOLT, WITH WASHER BOULON, AVEC RONDELLE	2				EXCEPT FOR VOLGA

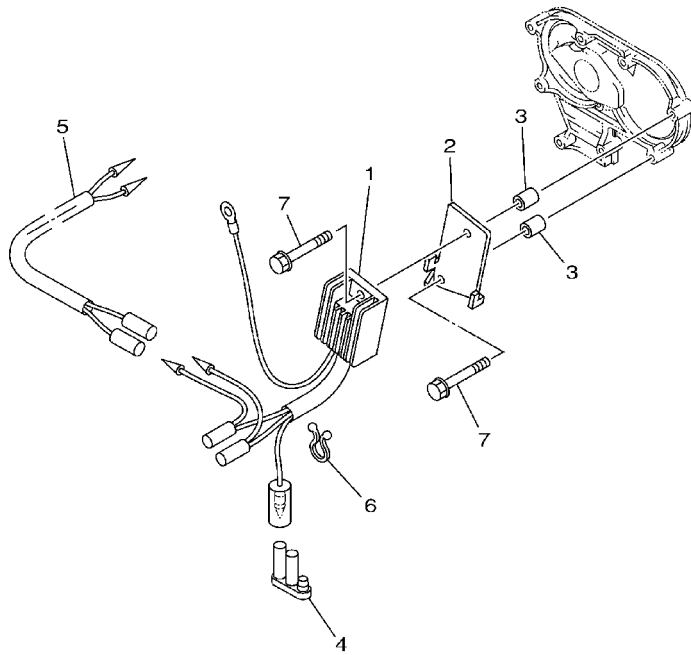

69R0664-1100

FIG. 11 ELECTRICAL 3

PARTIE ELECTRIQUE 3

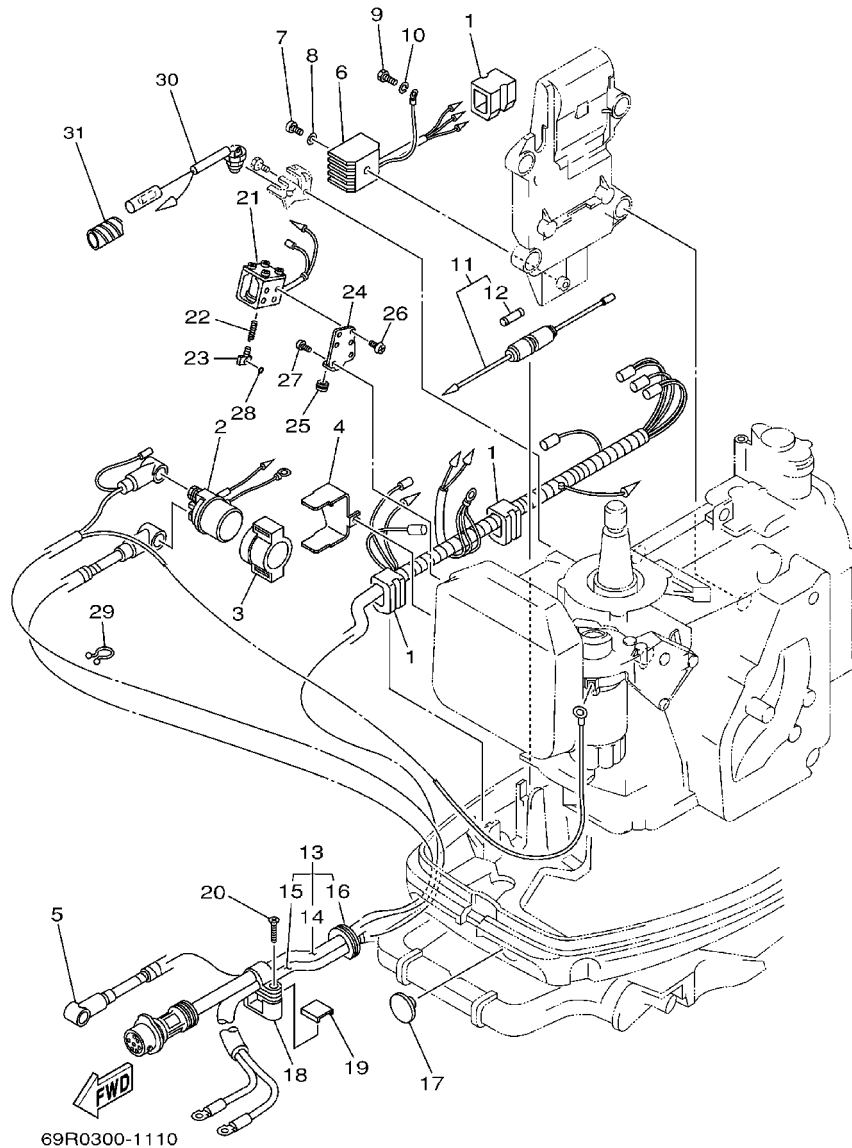

69R0300-1110

REF. NO.	PART NO. NO. PIECES	DESCRIPTION DESCRIPTION	25MH	30MH	25WC	30WC	REMARKS REMARQUES
1	90480-17M08	GROMMET PASSE-FIL			3	3	
2	6G1-81941-10	STARTER RELAY ASSY LANCEUR RELAIS (ENS.)			1	1	
3	6G1-81952-00	HOLDER, RELAY SUPPORT, RELAIS			1	1	
4	61T-81945-01	PLATE, SWITCH FITTING PLAQUE, FIXATION DU RELAIS			1	1	
5	689-82531-02	WIRE, LEAD FIL			1	1	
6	664-81970-61	RECTIFIER ASSY REDRESSEUR COMPLET			1	1	
7	97880-05025	SCREW, PAN HEAD VIS, TETE TRONCONIQUE			1	1	
8	92990-05600	WASHER, PLATE RONDELLE, PLATE			1	1	
9	97090-06012	BOLT BOULON			1	1	
10	92990-06100	WASHER, SPRING RONDELLE, GROWER			1	1	
11	682-82150-10	FUSE HOLDER ASSY SUPPORT DE FUSIBLE			1	1	
12	682-82151-00	.FUSE (20A) .FUSIBLE (20A)			1	1	
13	61T-82580-00	WIRE HARNESS ASSY 2 FAISCEAU DE FILS 2 CPLT			1	1	
14	61T-82590-00	.WIRE HARNESS ASSY .FAISCEAU DE FILS COMPLET			1	1	
15	689-82105-13	.WIRE HARNESS .FAISCEAU DE FILS			1	1	
16	689-42724-50	.GROMMET .PASSE-FIL			1	1	
17	90480-17165	GROMMET PASSE-FIL			1	1	
18	689-82594-10	CLAMP BRIDE			1	1	
19	682-42525-00	PLATE, FRICTION PLAQUE, FRICTION			1	1	
20	90161-06M00	SCREW, TAPPING VIS, TETE FRAISEE			1	1	
21	61T-86111-00	COIL, SOLENOID BOBINE			1	1	
22	682-86116-00	WIRE, PULL CABLE, TENSION			1	1	
23	682-86117-00	HOOK, WIRE PULL CROCHET, TENSION DE CABLE			1	1	
24	61T-86112-00	STAY, SOLENOID SUPPORT, SOLENOIDE			1	1	
25	90480-10155	GROMMET PASSE-FIL			1	1	
26	98503-04006	SCREW, PAN HEAD VIS, TETE TRONCONIQUE			4	4	
27	97880-05012	SCREW, PAN HEAD VIS, TETE TRONCONIQUE			2	2	

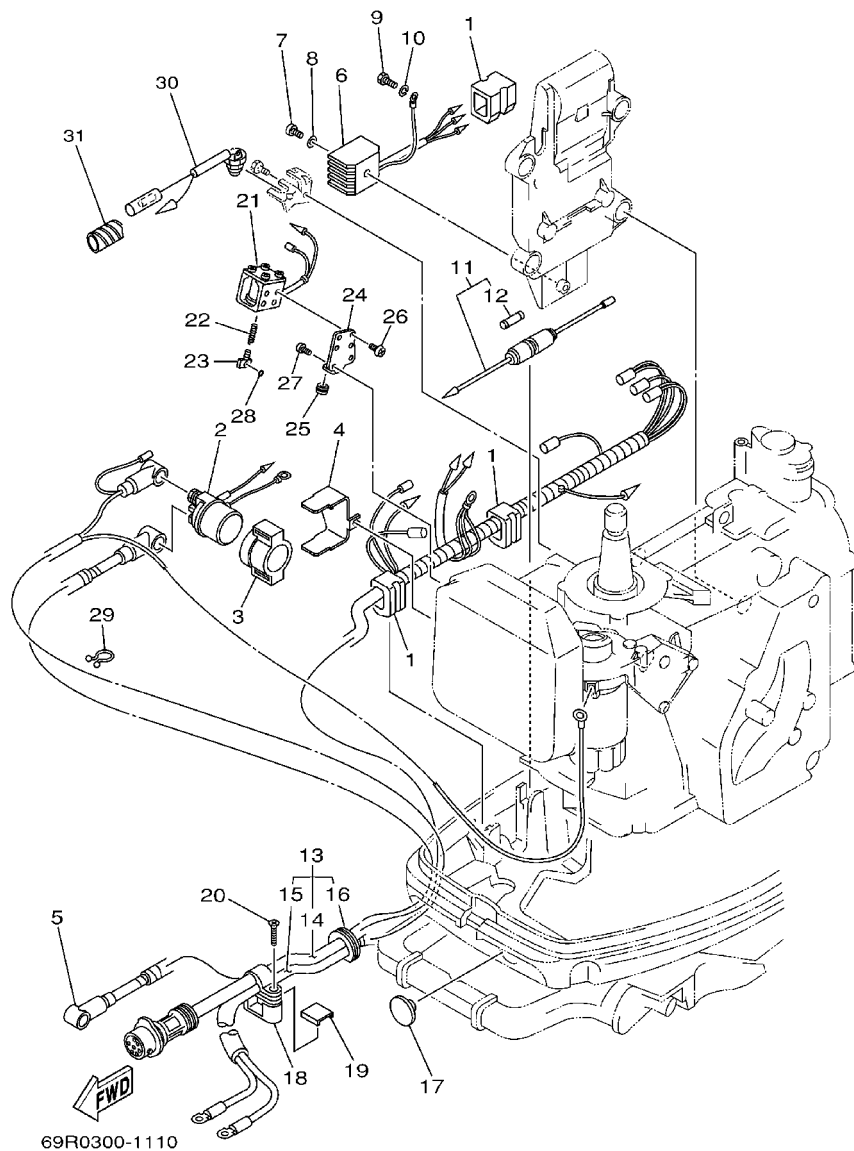

FIG. 11 ELECTRICAL 3

PARTIE ELECTRIQUE 3

REF. NO.	PART NO. NO. PIECES	DESCRIPTION DESCRIPTION	25MH	30MH	25WC	30WC	REMARKS REMARQUES
28	93210-03261	O-RING JOINT TORIQUE			1	1	
29	90465-18147	CLAMP BRIDE			1	1	
30	689-82540-01	NEUTRAL SWITCH ASSY CONTACTEUR DE POINT-MORT			1	1	
31	90446-10M02	HOSE DURITE			1	1	

FIG. 12 STARTING MOTOR

DEMARREUR ELECTRIQUE

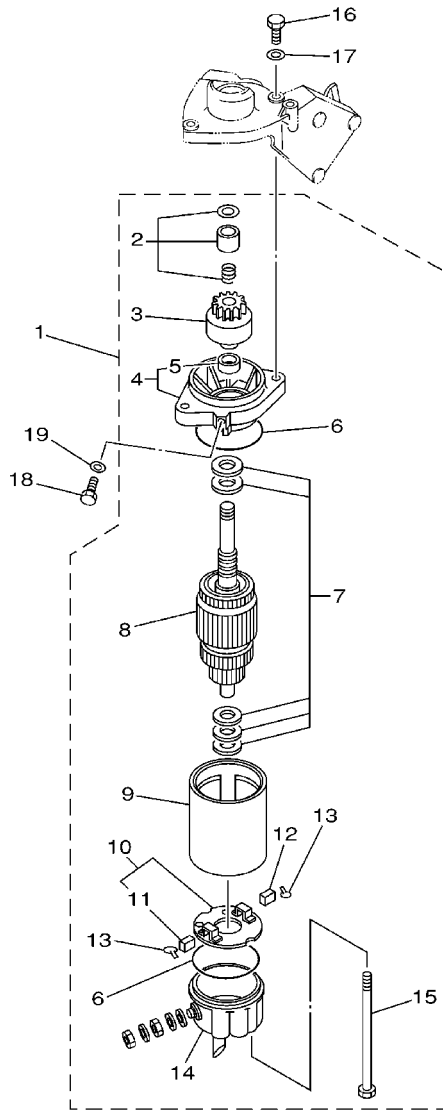

REF. NO.	PART NO. NO. PIECES	DESCRIPTION DESCRIPTION	25MH	30MH	25WC	30WC	REMARKS REMARQUES
1	689-81800-13	STARTING MOTOR ASSY DEMARREUR ELECTRIQUE COMPLET			1	1	
2	689-81857-11	.PINION STOPPER SET .BUTEE PIGNON			1	1	
3	689-81807-12	.GEAR ASSY, STARTING MOTOR .PIGNON, DEMARREUR ELECTRIQUE			1	1	
4	689-81830-11	.FRONT BRACKET ASSY .SUPPORT AVANT			1	1	
5	689-81831-00	..METAL, FRONT ..METAL, AVANT			1	1	
6	689-81847-11	.O-RING .JOINT TORIQUE			2	2	
7	689-81809-11	.WASHER KIT .JEU DE RONDELLES			1	1	
8	689-81850-12	.ARMATURE ASSY .INDUIT			1	1	
9	689-81810-11	.STATOR ASSY .STATOR COMPLET			1	1	
10	689-81840-11	.BRUSH HOLDER ASSY .SUPPORT DE CHARBON			1	1	
11	689-81812-11	..BRUSH 2 ..CHARBON 2			1	1	
12	689-81811-11	.BRUSH 1 .CHARBON 1			1	1	
13	689-81813-10	.SPRING, BRUSH .RESSORT, DE CHARBON			2	2	
14	689-81820-11	.REAR BRACKET ASSY .SUPPORT ARRIERE COMPLET			1	1	
15	689-81826-10	.BOLT .BOULON			2	2	
16	97013-08030	.BOLT BOULON			2	2	
17	92903-08600	WASHER, PLATE RONDELLE, PLATE			2	2	
18	97013-08012	.BOLT BOULON			1	1	
19	92903-08600	WASHER, PLATE RONDELLE, PLATE			1	1	



61R0010-4110

FIG. 13 BOTTOM COWLING

CAPOT INFERIEUR

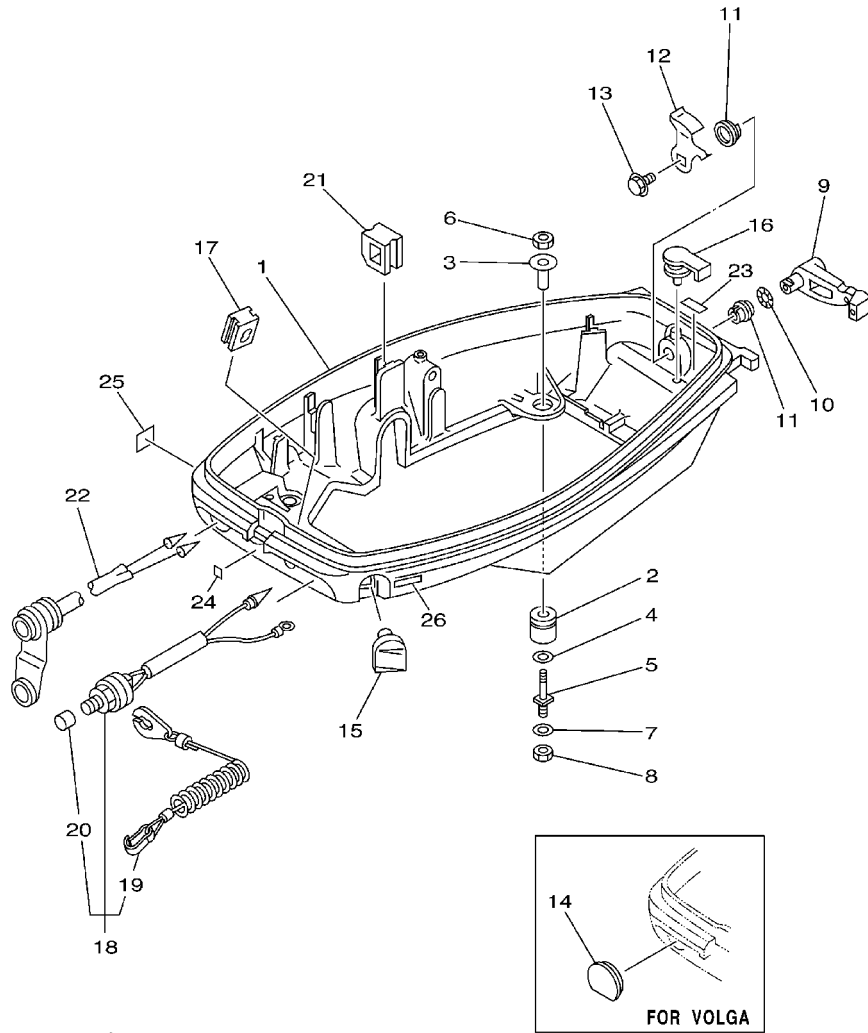

69R2300-2130

REF. NO.	PART NO. NO. PIECES	DESCRIPTION DESCRIPTION	25MH	30MH	25WC	30WC	REMARKS REMARQUES
1	689-42711-04-4D	COWLING, BOTTOM CUVETTE	1	1	1	1	
2	90480-15M06	GROMMET PASSE-FIL	4	4	4	4	
3	90387-08M25	COLLAR COLLERETTE	4	4	4	4	
4	90201-08M87	WASHER, PLATE RONDELLE, PLATE	4	4	4	4	
5	6G0-42796-00	BOLT 1 BOULON	4	4	4	4	
6	95380-08700	NUT ECROU	4	4	4	4	
7	92995-08600	WASHER RONDELLE	4	4	4	4	
8	95380-08700	NUT ECROU	4	4	4	4	
9	689-42815-00	LEVER, CLAMP LEVIER, PRESSE	1	1	1	1	
10	90206-12052	WASHER, WAVE RONDELLE, ONDULEE	1	1	1	1	
11	90386-12069	BUSH DOUILLE	2	2	2	2	
12	689-42816-00	LEVER, CLAMP LEVIER, PRESSE	1	1	1	1	
13	90119-06M73	BOLT, WITH WASHER BOULON, AVEC RONDELLE	1	1	1	1	
14	682-42724-00	GROMMET PASSE-FIL	1	1			FOR VOLGA
15	689-42725-01	GROMMET PASSE-FIL	1	1	1	1	
16	647-42523-00	SPACER, FRICTION ENTRETOISE, FRICTION	1	1	1	1	
17	61N-26326-00	GROMMET RONDELLE CAOUTCHOUC	1	1	1	1	
18	6E9-82575-02	ENGINE STOP SWITCH ASSY COUPE CIRCUIT CPLT	1	1			
19	682-82556-00	.STOPPER .PLAQUETTE	1	1			
20	689-8257Y-00	.CAP .CHAPEAU	1	1			
21	90480-17M08	GROMMET PASSE-FIL	2				EXCEPT FOR VOLGA
	90480-17M08	GROMMET PASSE-FIL	1	1			FOR VOLGA
22	682-84381-00	2P CONCENT RALLONGE 2 FILS	1				EXCEPT FOR VOLGA
23	6E7-42791-10	MARK 1 ETIQUETTE 1	1				
	6E7-42791-00	MARK 1 ETIQUETTE 1	1		1		FOR VOLGA
	6G5-42791-00	MARK 1 ETIQUETTE 1		1		1	FOR VOLGA
24	6A1-42792-01	MARK (100:1) ETIQUETTE (100:1)	1				EXCEPT FOR VOLGA

FIG. 13 BOTTOM COWLING

CAPOT INFÉRIEUR

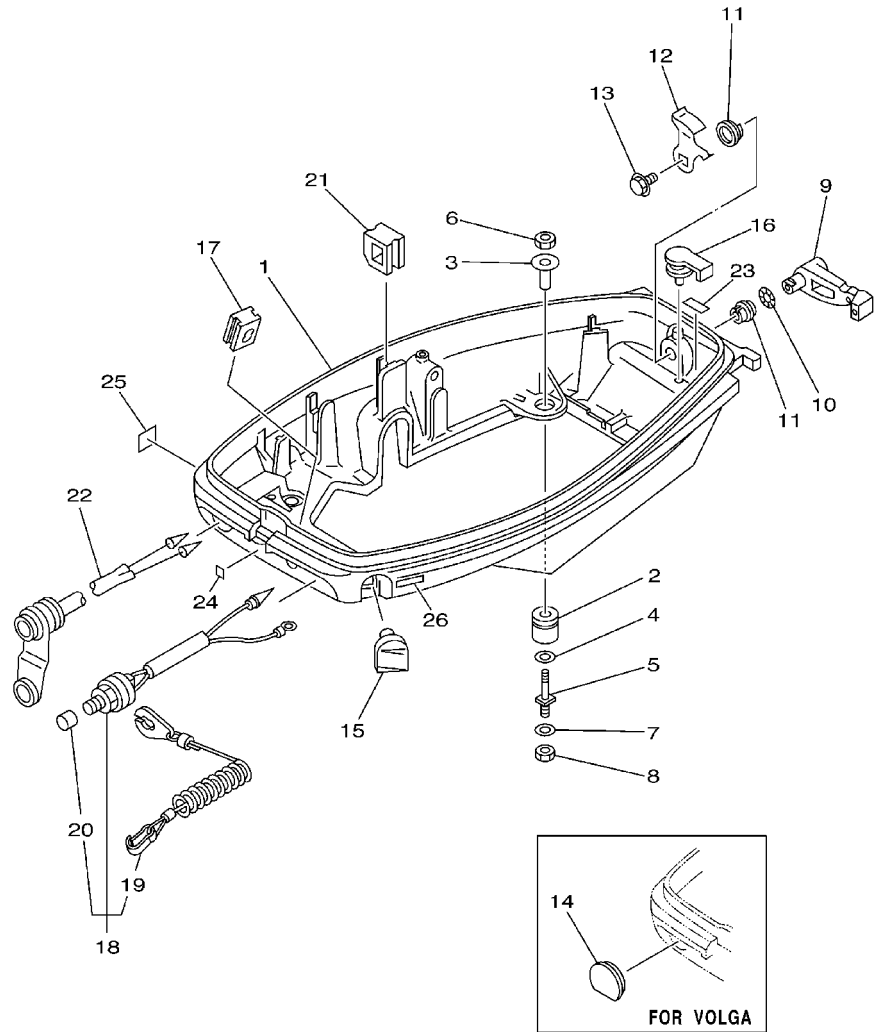

69R2300-2130

REF. NO.	PART NO. NO. PIECES	DESCRIPTION DESCRIPTION	25MH	30MH	25WC	30WC	REMARKS REMARQUES
25	6A1-28176-00	LABEL, CAUTION ETIQUETTE, RECOMMANDATION	1				EXCEPT FOR VOLGA
26	6E3-8257H-00	PLATE, MARK PLAQUE, ADHESIF	1				EXCEPT FOR VOLGA



69R2664-2140

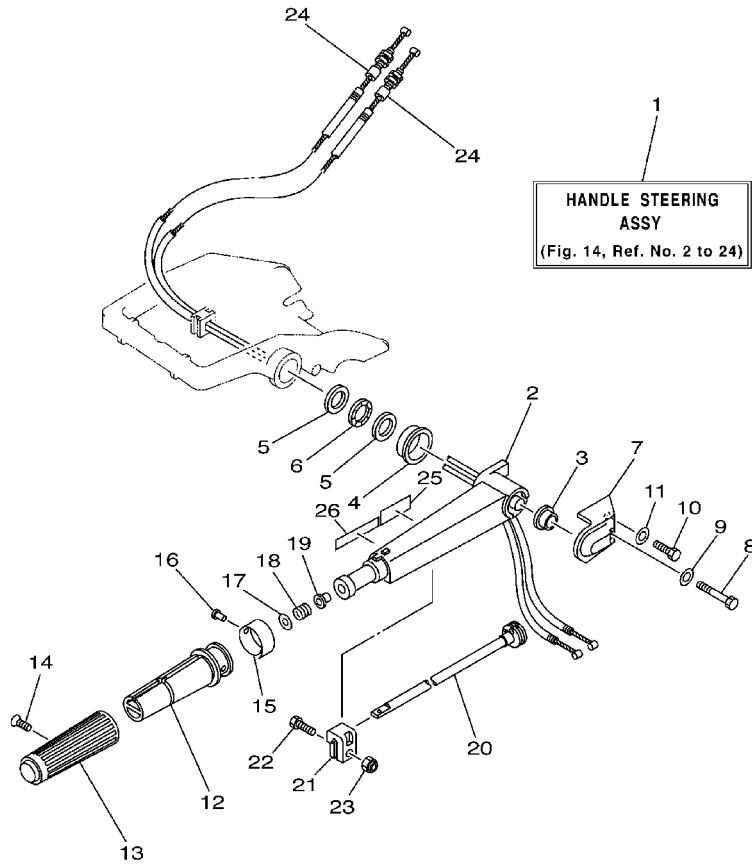

FIG. 14 STEERING

DIRECTION

REF. NO.	PART NO. NO. PIECES	DESCRIPTION DESCRIPTION	DIRECTION				REMARKS REMARQUES
			25MH	30MH	25WC	30WC	
1	69P-W0084-00-4D	HANDLE STEERING ASSY BARRE FRANCHE (ENS.)	1	1	1	1	
2	689-42111-01-4D	HANDLE, STEERING POIGNEE	1	1	1	1	
3	90387-13003	COLLAR COLLERETTE	1	1	1	1	
4	90387-33001	COLLAR COLLERETTE	1	1	1	1	
5	90201-28013	WASHER, PLATE RONDELLE, PLATE	2	2	2	2	
6	90206-28001	WASHER, WAVE RONDELLE, ONDULEE	1	1	1	1	
7	69P-42112-00-4D	HANDLE, STEERING POIGNEE	1	1	1	1	
8	97095-06050	BOLT BOULON	1	1	1	1	
9	92995-06600	WASHER RONDELLE	1	1	1	1	
10	97095-06020	BOLT BOULON	1	1	1	1	
11	92995-06600	WASHER RONDELLE	1	1	1	1	
12	664-42119-00	GRIP, STEERING HANDLE POIGNEE, BARRE FRANCHE	1	1	1	1	
13	6F6-42177-A0	RUBBER, HANDLE CAOUTCHOUC, POIGNEE	1	1	1	1	
14	90149-05M13	SCREW VIS	1	1	1	1	
15	6G1-42137-10	INDICATOR, THROTTLE INDICATEUR, ACCELERATION	1	1	1	1	
16	90269-02M09	RIVET RIVET	1	1	1	1	
17	92903-10600	WASHER, PLATE RONDELLE, PLATE	1	1	1	1	
18	90501-23215	SPRING, COMPRESSION RESSORT, COMPRESSION	1	1	1	1	
19	90386-08032	BUSH DOUILLE	1	1	1	1	
20	689-42138-00	LEVER, THROTTLE LEVIER, ACCELERATEUR	1	1	1	1	
21	656-42126-01	FRICTION, STEERING HANDLE GRIP CUVETTE, POIGNEE DE DIRECTION	1	1	1	1	
22	97095-06020	BOLT BOULON	1	1	1	1	
23	90185-06062	NUT, SELF-LOCKING ECROU, AUTO-BLOCANT	1	1	1	1	
24	61N-26311-00	CABLE, THROTTLE 1 CABLE 1, ACCELERATEUR	2	2	2	2	
25	6E0-83627-51	LABEL, CAUTION 7 ETIQUETTE, RECOMMANDATION 7	1				
26	61T-83627-80	LABEL, CAUTION 7 ETIQUETTE, RECOMMANDATION 7	1	1	1	1	FÖR VÖLGA
26	6E0-83627-41	LABEL, CAUTION 7 ETIQUETTE, RECOMMANDATION 7	1	1	1	1	

D3

FIG. 15 CONTROL 1

COMMANDE 1

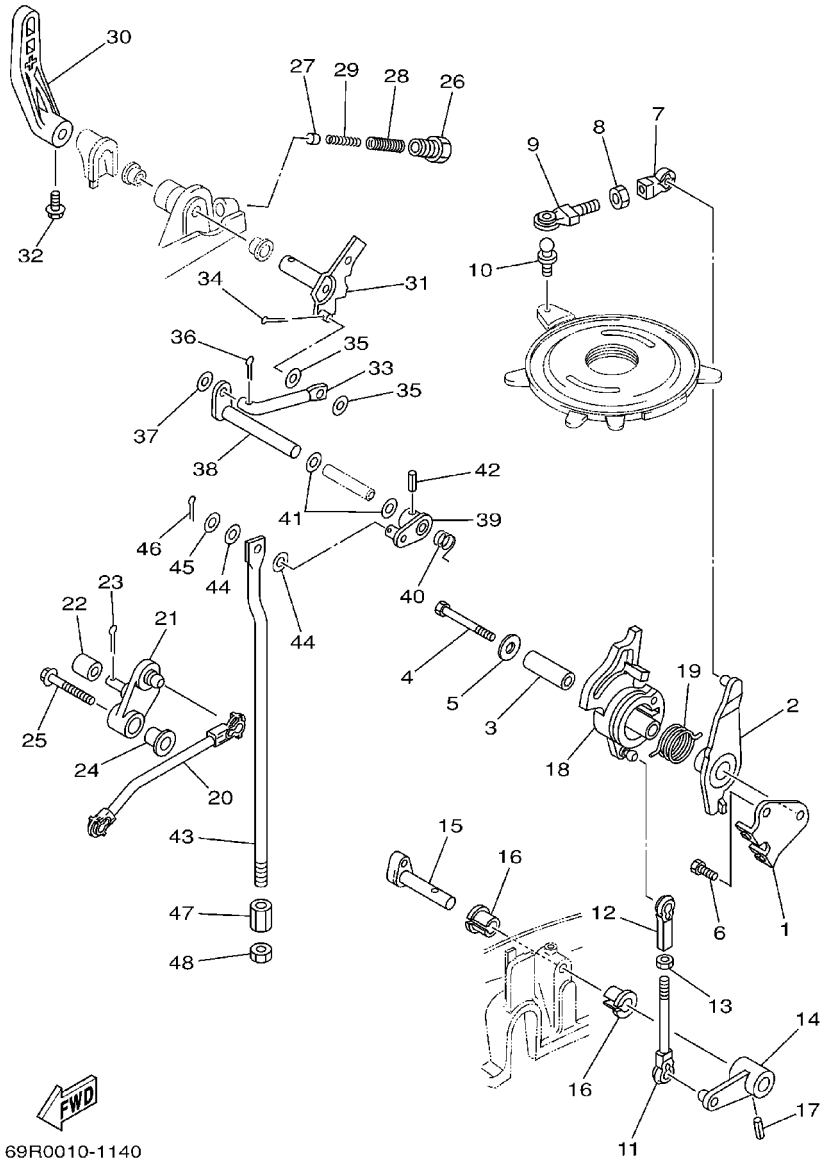

FWD
69R0010-1140

REF. NO.	PART NO. NO. PIECES	DESCRIPTION DESCRIPTION	25MH	30MH	25WC	30WC	REMARKS REMARQUES
1	69P-14497-00	STAY, THROTTLE WIRE SUPPORT DE BOISSEAU	1	1	1	1	
2	69P-41631-00	LEVER, MAGNETO CONTROL LEVIER, COMMANDE D'AVANCE	1	1	1	1	
3	90387-06M59	COLLAR COLLERETTE	1	1	1	1	
4	97095-06045	BOLT BOULON	1	1	1	1	
5	90201-06416	WASHER, PLATE RONDELLE, PLATE	1	1	1	1	
6	97095-06012	BOLT BOULON	1	1	1	1	
7	662-41237-01	JOINT, LINK RACCORD	1	1	1	1	
8	95380-05700	NUT ECROU	1	1	1	1	
9	679-41241-01	ROD, LINK BIELLETTTE	1	1	1	1	
10	663-85518-00	JOINT, BALL JOINT SPHERIQUE	1	1	1	1	
11	682-41238-01	JOINT, LINK RACCORD	1	1	1	1	
12	682-41237-00	JOINT, LINK RACCORD	1	1	1	1	
13	95380-05600	NUT ECROU	1	1	1	1	
14	69P-42157-00-94	LEVER, THROTTLE LEVIER DE AVANCE	1	1	1	1	
15	656-42153-00-94	SHAFT, THROTTLE CONTROL AXE, COMMANDE D'ACCELERATION	1	1	1	1	
16	90386-10009	BUSH DOUILLE	2	2	2	2	
17	91690-40018	PIN, SPRING GOUPILLE, ELASTIQUE	1	1	1	1	
18	69P-41213-00	CAM, ACCEL. CAME, ACCELERATION	1	1	1	1	
19	69P-42167-00	SPRING 1 RESSORT1	1	1	1	1	
20	69P-41241-00	ROD, LINK BIELLETTTE	1	1	1	1	
21	69P-42154-00	LEVER, THROTTLE CONTROL LEVIER DE COMMANDE D'AVANCE	1	1	1	1	
22	62Y-42171-00	BUSHING COUSSINET	1	1	1	1	
23	91490-16010	PIN, COTTER GOUPILLE, FENDUE	1	1	1	1	
24	90387-06M60	COLLAR COLLERETTE	1	1	1	1	
25	90119-06M17	BOLT, WITH WASHER BOULON, AVEC RONDELLE	1	1	1	1	
26	664-42715-00	BUSHING COUSSINET	1	1	1	1	
27	664-44167-01	PLUNGER, SHIFT CAM POUSSOIR D'EMBRAYAGE	1	1	1	1	

FIG. 15 CONTROL 1

COMMANDE 1

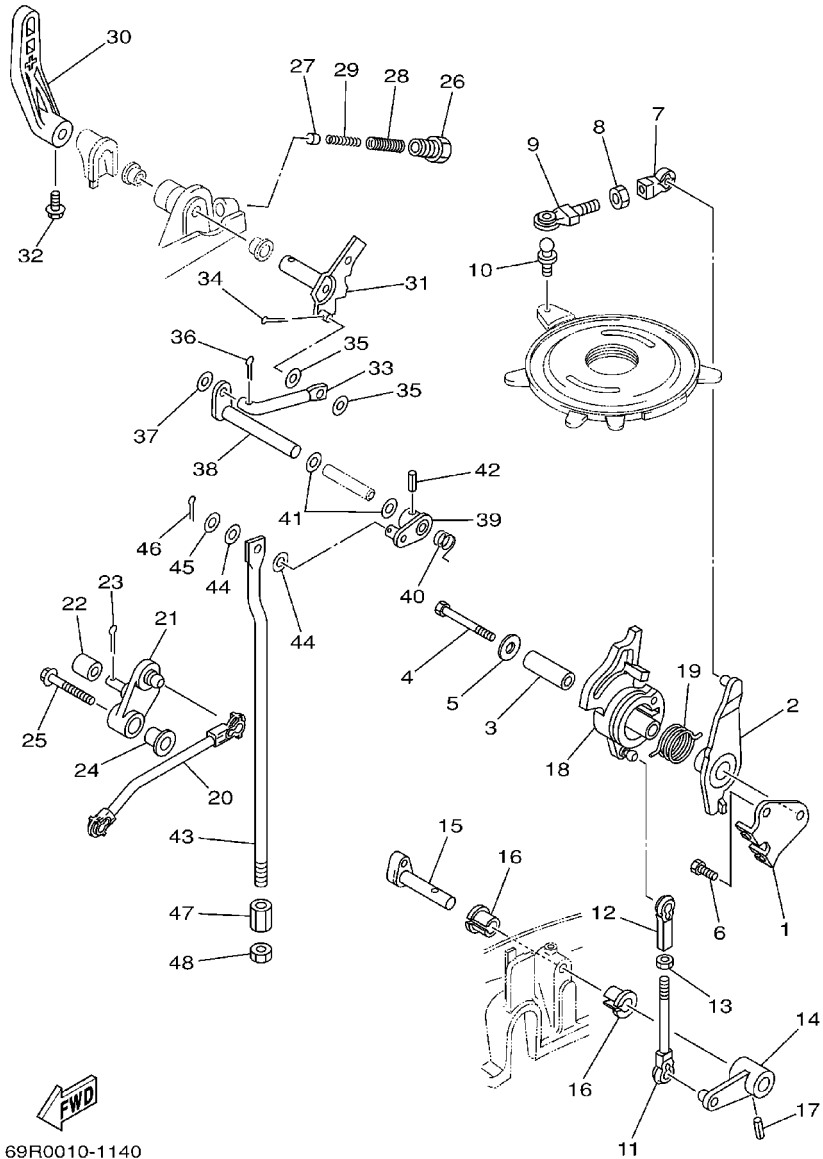

69R0010-1140

REF. NO.	PART NO. NO. PIECES	DESCRIPTION DESCRIPTION	25MH	30MH	25WC	30WC	REMARKS REMARQUES
28	90501-14M07	SPRING, COMPRESSION RESSORT, COMPRESSION	1	1	1	1	
29	90501-09M08	SPRING, COMPRESSION RESSORT, COMPRESSION	1	1	1	1	
30	689-44111-01-4D	HANDLE, GEAR SHIFT POIGNEE, LEVIER D'EMBRAYAGE	1	1	1	1	
31	664-44113-01	CAM PLATE, HANDLE CAME, VERROUILLAGE	1	1	1	1	
32	90105-06M07	BOLT, FLANGE BOULON	1	1	1	1	
33	664-44142-00	JOINT RACCORD	1	1	1	1	
34	91490-16010	PIN, COTTER GOUPILLE, FENDUE	1	1	1	1	
35	90202-06007	WASHER, PLATE RONDELLE, PLATE	2	2	2	2	
36	91490-12010	PIN, COTTER GOUPILLE, FENDUE	1	1	1	1	
37	92990-05600	WASHER, PLATE RONDELLE, PLATE	1	1	1	1	
38	689-44121-01	LEVER, SHIFT ROD LEVIER, TIGE D'INVERSION	1	1	1	1	
39	689-44125-00	LEVER, SHIFT ROD LEVIER, TIGE D'INVERSION	1	1	1	1	
40	90508-14M13	SPRING, TORSION RESSORT, TORSION	1	1	1	1	
41	90202-10024	WASHER, PLATE RONDELLE, PLATE	2	2	2	2	
42	91690-40016	PIN, SPRING GOUPILLE, ELASTIQUE	1	1	1	1	
43	61N-44143-00	ROD, SHIFT TIGE D'EMBRAYAGE	1	1	1	1	
44	90202-06007	WASHER, PLATE RONDELLE, PLATE	2	2	2	2	
45	92990-05600	WASHER, PLATE RONDELLE, PLATE	1	1	1	1	
46	91490-20010	PIN, COTTER GOUPILLE, FENDUE	1	1	1	1	
47	61N-44146-00	CONNECTOR, SHIFT ROD CONNECTEUR, TIGE D'INVERSION	1	1	1	1	
48	95380-06600	NUT, HEXAGON ECROU	1	1	1	1	

FIG. 16 CONTROL 2

COMMANDE 2

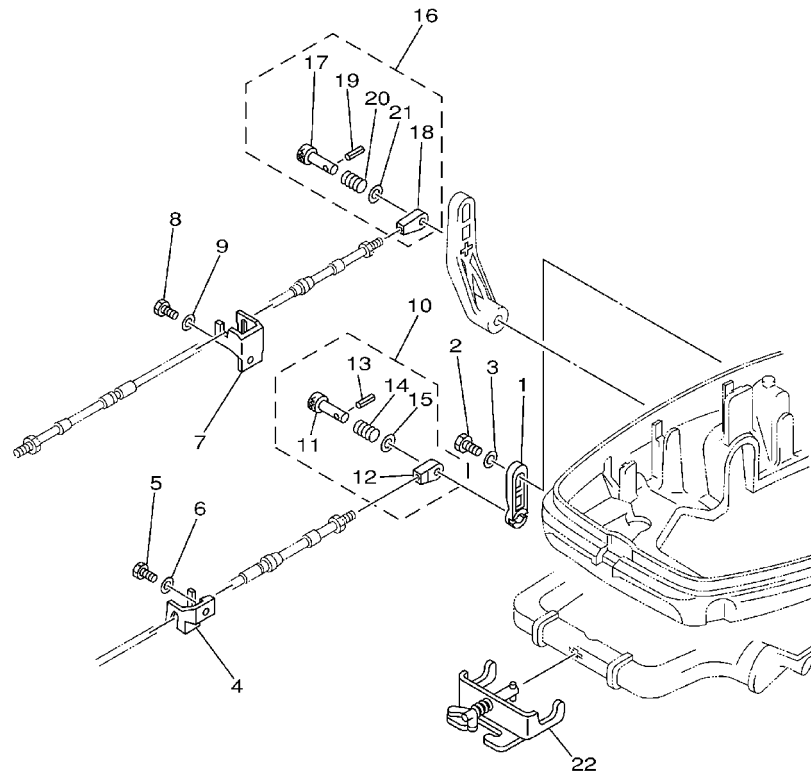

REF. NO.	PART NO. NO. PIECES	DESCRIPTION DESCRIPTION	25MH	30MH	25WC	30WC	REMARKS REMARQUES
1	648-48534-50-4D	THROTTLE LEVER, CONTROL LEVIER D'ACCELERATION			1	1	
2	97095-06012	BOLT BOULON			1	1	
3	92995-06600	WASHER RONDELLE			1	1	
4	689-48532-50	BRACKET, REMOTE CONTROL 2 ETRIER 2, COMMANDE A DISTANCE			1	1	
5	97095-06016	BOLT BOULON			1	1	
6	92995-06600	WASHER RONDELLE			1	1	
7	689-48531-50	BRACKET, REMOTE CONTROL 1 ETRIER 1, COMMANDE A DISTANCE			1	1	
8	97095-06016	BOLT BOULON			1	1	
9	92995-06600	WASHER RONDELLE			1	1	
10	648-48340-50	CABLE END ASSY .CHAPE CABLE			1	1	
11	617-48361-91	.HOOK, CABLE .CROCHET, CABLE			1	1	
12	617-48346-90	.CABLE END, REMOTE CONTROL .CHAPE CABLE			1	1	
13	91690-30012	.PIN, SPRING .GOUPILLE, ELASTIQUE			1	1	
14	90501-10264	.SPRING, COMPRESSION .RESSORT, COMPRESSION			1	1	
15	92990-08600	.WASHER, PLATE .RONDELLE, PLATE			1	1	
16	648-48330-50	CABLE END ASSY RACCORD DE CABLE			1	1	
17	617-48331-91	.HOOK, CABLE .CROCHET, CABLE			1	1	
18	648-48346-50	.CABLE END, REMOTE CONTROL .CHAPE CABLE			1	1	
19	91690-30012	.PIN, SPRING .GOUPILLE, ELASTIQUE			1	1	
20	90501-10071	.SPRING, COMPRESSION .RESSORT, COMPRESSION			1	1	
21	92990-08600	.WASHER, PLATE .RONDELLE, PLATE			1	1	
22	700-48510-12	STEERING HOOK ASSY ATTACHE DE DIRECTION (ENS.)			1	1	ROPE TYPE



69R0300-1160

FIG. 17 BRACKET 1

SUPPORT 1

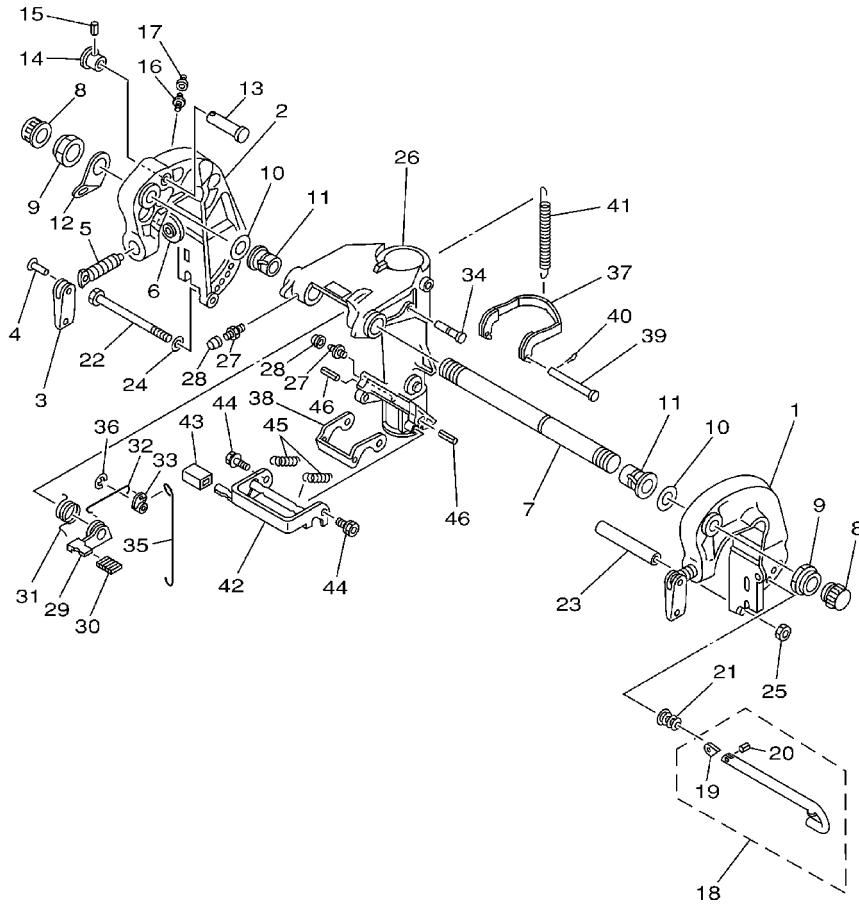

69R0010-1150

REF. NO.	PART NO. NO. PIECES	DESCRIPTION DESCRIPTION	25MH	30MH	25WC	30WC	REMARKS REMARQUES
1	689-43111-03-4D	BRACKET, CLAMP PRESSE	1	1	1	1	
2	689-43112-02-4D	BRACKET, CLAMP PRESSE	1	1	1	1	
3	6E0-43118-01	HANDLE, TRANSOM CLAMP POIGNEE DE VIS DE PRESSE	2	2	2	2	
4	90243-04M01	PIN GOUPILLE	2	2	2	2	
5	90149-14030	SCREW VIS	2	2	2	2	
6	648-43114-01	PAD, TRANSOM CLAMP RONDELLE D'APPUI	2	2	2	2	
7	6J8-43131-01	BOLT, CLAMP BRACKET BOULON, PRESSE	1	1	1	1	
8	6G5-43145-01	CAP, CLAMP BRACKET CAPUCHON, PRESSE	2	2	2	2	
9	90185-22043	NUT, SELF-LOCKING ECROU, AUTO-BLOCANT	2	2	2	2	
10	90201-22M03	WASHER, PLATE RONDELLE, PLATE	2	2	2	2	
11	90386-22M67	BUSH DOUILLE	2	2	2	2	
12	6J8-43113-01	PLATE, CLAMP BRACKET PLAQUETTE, PRESSE	1	1	1	1	
13	689-43191-00	SHAFT, STOPPER AXE, BUTEE	1	1	1	1	
14	689-43192-01	KNOB, STOPPER BOUTON, BUTEE DE RELEVAGE	1	1	1	1	
15	91690-30016	PIN, SPRING GOUPILLE, ELASTIQUE	1	1	1	1	
16	93700-06M03	NIPPLE, GREASE GRAISSEUR	1	1	1	1	
17	663-45119-00	CAP, GREASE NIPPLE CAPUCHON, GRAISSEUR	1	1	1	1	AP
18	689-43160-00	TILT ROD ASSY BROCHE D'INCLINAISON (ENS.)	1	1	1	1	
19	689-43165-00	.PLATE, TILT LOCK .TAQUET, BROCHE INCLINAISON	1	1	1	1	
20	91690-30008	.PIN, SPRING .GOUPILLE, ELASTIQUE	1	1	1	1	
21	90502-10M07	SPRING, CONICAL RESSORT, CONIQUE	1	1	1	1	
22	90101-08339	BOLT BOULON	1	1	1	1	
23	90387-08M03	COLLAR COLLERETTE	1	1	1	1	
24	92995-08600	WASHER RONDELLE	1	1	1	1	
25	95380-08600	NUT ECROU	1	1	1	1	
26	689-43311-03-4D	BRACKET, SWIVEL 1 SUPPORT, PIVOT 1	1	1	1	1	
27	93700-06M03	NIPPLE, GREASE GRAISSEUR	3	3	3	3	

FIG. 17 BRACKET 1

SUPPORT 1

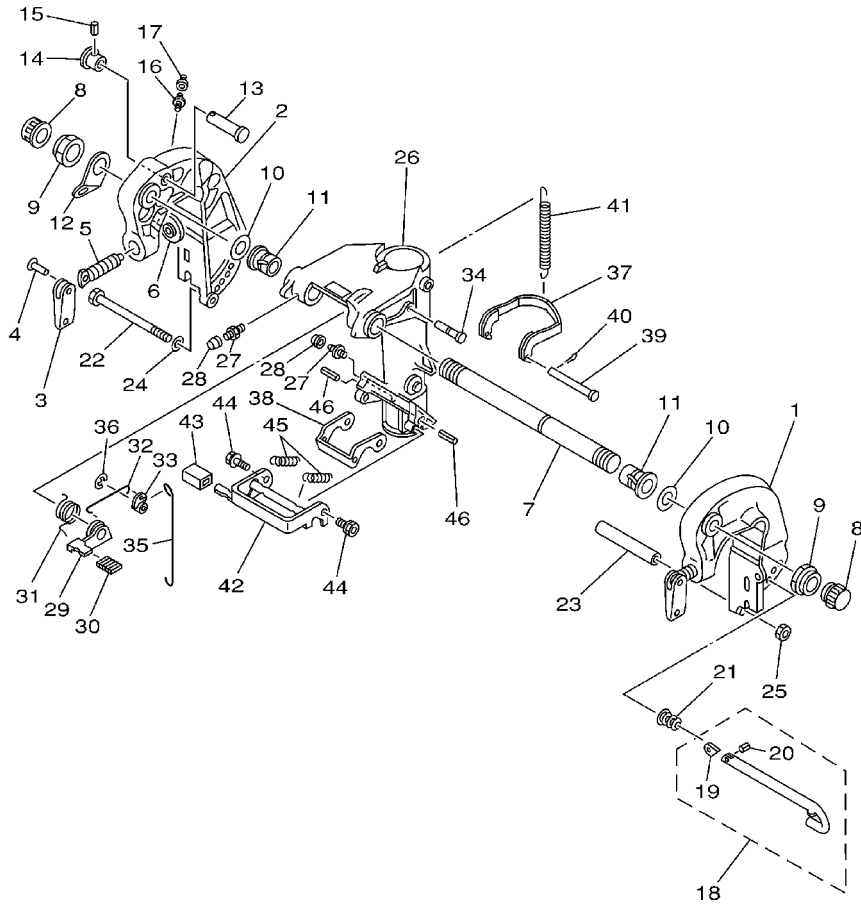

69R0010-1150

REF. NO.	PART NO. NO. PIECES	DESCRIPTION DESCRIPTION	25MH	30MH	25WC	30WC	REMARKS REMARQUES
28	663-45119-00	CAP, GREASE NIPPLE CAPUCHON, GRAISSEUR	3	3	3	3	AP
29	689-43631-00	LEVER, TILT LEVIER, INCLINAISON	1	1	1	1	
30	689-43633-00	COVER, TILT LEVER COUVERCLE	1	1	1	1	
31	689-43643-00	SPRING RESSORT	1	1	1	1	
32	689-43616-00	ROD, TILT LOCK TIGE	1	1	1	1	
33	648-43642-00	LEVER, TILT 1 LEVIER, INCLINAISON 1	1	1	1	1	
34	90249-06M22	PIN GOUPILLE	1	1	1	1	
35	648-43617-00	ROD, TILT LOCK TIGE	1	1	1	1	
36	99080-05600	CIRCLIP CIRCLIP	1	1	1	1	
37	689-43614-01	PLATE, TILT LOCK ETRIER, VERROUILLAGE MARCHE AR	1	1	1	1	
38	648-43615-00	PLATE, TILT LOCK ETRIER, VERROUILLAGE MARCHE AR	1	1	1	1	
39	90240-05047	PIN, CLEVIS BOULON, A GOUPILLE	1	1	1	1	
40	91490-16010	PIN, COTTER GOUPILLE, FENDUE	1	1	1	1	
41	90506-30M27	SPRING, TENSION RESSORT, TENSION	1	1	1	1	
42	689-43681-01	LEVER, SHALLOW WATER DRIVE 1 LEVIER, PEU PROFOND D'EAU 1	1	1	1	1	FOR VOLGA
43	682-43318-01	COVER CAPUCHON	1	1	1	1	FOR VOLGA
44	90109-06M18	BOLT BOULON	2	2	2	2	FOR VOLGA
45	90506-16M17	SPRING, TENSION RESSORT, TENSION	2	2	2	2	FOR VOLGA
46	91690-40035	PIN, SPRING GOUPILLE, ELASTIQUE	2	2	2	2	FOR VOLGA

FIG. 18 BRACKET 2

SUPPORT 2

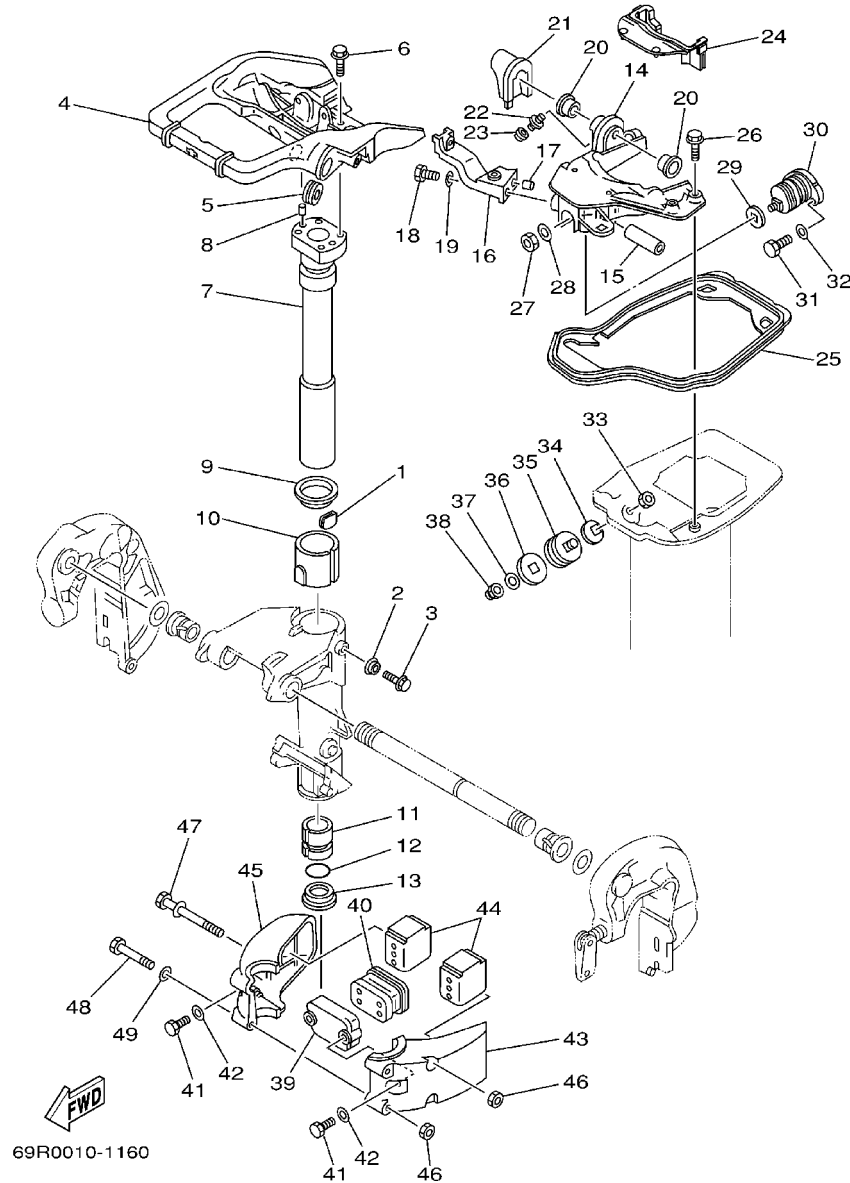

69R0010-1160

REF. NO.	PART NO. NO. PIECES	DESCRIPTION DESCRIPTION	25MH	30MH	25WC	30WC	REMARKS REMARQUES
1	648-42528-00	PLATE, FRICTION PLAQUE, FRICTION	1	1	1	1	
2	689-43373-01	SEAL, DAMPER JOINT	1	1	1	1	
3	90105-06M18	BOLT, FLANGE BOULON	1	1	1	1	
4	69P-42511-00-4D	BRACKET, STEERING CADRE, DIRECTION	1	1	1	1	
5	90480-29045	GROMMET PASSE-FIL	1	1	1	1	
6	90105-06M07	BOLT, FLANGE BOULON	4	4	4	4	
7	689-42521-00-94	SHAFT, STEERING PIVOT AXE, PIVOT DE DIRECTION	1	1	1	1	
8	93608-12063	PIN, DOWEL GOUJON	2	2	2	2	
9	90209-47016	WASHER RONDELLE	1	1	1	1	
10	90386-47M22	BUSH DOUILLE	1	1	1	1	
11	90386-38090	BUSH DOUILLE	1	1	1	1	
12	93210-37160	O-RING JOINT TORIQUE	1	1	1	1	
13	90386-38022	BUSH DOUILLE	1	1	1	1	
14	69P-44518-00-94	BRACKET COMP. SUPPORT COMPLET	1	1	1	1	
15	90387-10M39	COLLAR COLLERETTE	1	1	1	1	
16	648-44519-00-94	BRACKET SUPPORT	1	1	1	1	
17	93606-12019	PIN, DOWEL GOUJON	1	1	1	1	
18	97095-06018	BOLT BOULON	1	1	1	1	
19	92995-06600	WASHER RONDELLE	1	1	1	1	
20	90381-12M01	BUSH, SOLID DOUILLE, SOLIDE	2	2	2	2	
21	689-42718-00	RUBBER, SEAL 3 JOINT	1	1	1	1	
22	93700-06M03	NIPPLE, GREASE GRAISSEUR	1	1	1	1	
23	663-45119-00	CAP, GREASE NIPPLE CAPUCHON, GRAISSEUR	1	1	1	1	AP
24	69P-42717-00	RUBBER, SEAL 2 JOINT EN CAOUTCHOUC 2	1	1	1	1	
25	69P-42716-00	RUBBER, SEAL 1 JOINT EN CAOUTCHOUC 1	1	1	1	1	
26	90105-06M08	BOLT, FLANGE BOULON	4	4	4	4	
27	90170-10M42	NUT ECROU	1	1	1	1	

FIG. 18 BRACKET 2

SUPPORT 2

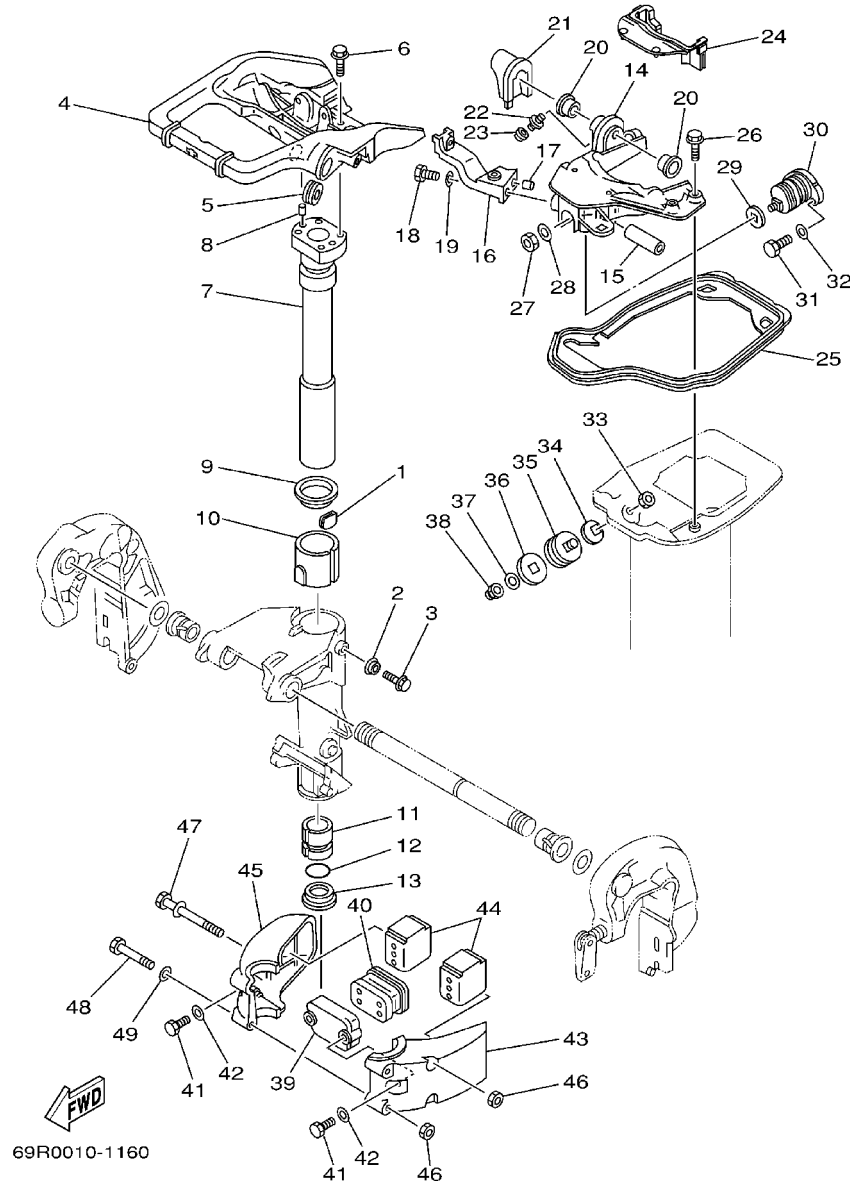

REF. NO.	PART NO. NO. PIECES	DESCRIPTION DESCRIPTION	25MH	30MH	25WC	30WC	REMARKS REMARQUES
28	92990-10200	WASHER, PLAIN RONDELLE, PLATE	1	1	1	1	
29	648-44591-A0	GASKET JOINT	1	1	1	1	
30	689-44516-00	MOUNT DAMPER, UPPER FRONT SILENT-BLOC, SUPERIEUR AVANT	1	1	1	1	
31	97095-06020	BOLT BOULON	2	2	2	2	
32	92995-06600	WASHER RONDELLE	2	2	2	2	
33	90170-10M42	NUT ECROU	2	2	2	2	
34	648-44591-A0	GASKET JOINT	2	2	2	2	
35	664-44514-00-94	MOUNT DAMPER, UPPER SIDE SILENT-BLOC, SUPERIEUR LATERAL	2	2	2	2	
36	664-44591-A0	GASKET JOINT	2	2	2	2	
37	92990-10200	WASHER, PLAIN RONDELLE, PLATE	2	2	2	2	
38	90176-10M01	NUT, CROWN ECROU BORGNE	2	2	2	2	
39	689-44553-00-94	COVER, LOWER MOUNT COUVERCLE, SUSPENSION INFERIEU	1	1	1	1	
40	689-44557-00	MOUNT DAMPER, LOWER FRONT SILENT-BLOC, INFERIEUR AVANT	1	1	1	1	
41	97075-08025	BOLT BOULON	2	2	2	2	
42	92995-08600	WASHER RONDELLE	2	2	2	2	
43	689-44551-01-4D	HOUSING, LOWER MOUNT RUBBER BOITIER, SILENT-BLOC INFERIEUR	1	1	1	1	
44	689-44555-00	MOUNT DAMPER, LOWER SIDE SILENT-BLOC, INFERIEUR LATERAL	2	2	2	2	
45	689-44552-01-4D	HOUSING, LOWER MOUNT RUBBER BOITIER, SILENT-BLOC INFERIEUR	1	1	1	1	
46	95380-08600	NUT ECROU	4	4	4	4	
47	90119-08M03	BOLT, WITH WASHER BOULON, AVEC RONDELLE	2	2	2	2	
48	97095-08065	BOLT BOULON	2	2	2	2	
49	92995-08600	WASHER RONDELLE	2	2	2	2	

FIG. 19 UPPER CASING

FOURREAU

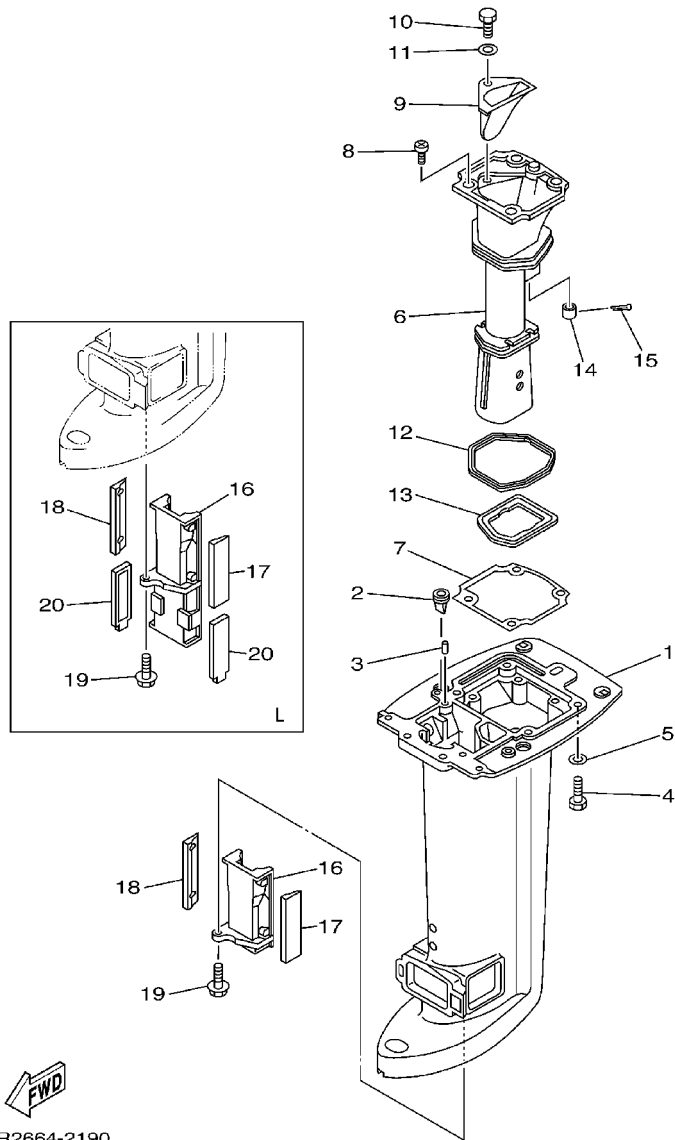

69R2664-2190

REF. NO.	PART NO. NO. PIECES	DESCRIPTION DESCRIPTION	25MH	30MH	25WC	30WC	REMARKS REMARQUES
1	69P-45111-00-4D	CASING, UPPER FOURREAU	1	1	1	1	S
	69P-45111-10-4D	CASING, UPPER FOURREAU	1				L
2	65W-42717-00	RUBBER, SEAL 2 JOINT EN CAOUTCHOUC 2	2	2	2	2	
3	93606-12019	PIN, DOWEL GOUJON	2	2	2	2	
4	97075-08030	BOLT BOULON	6	6	6	6	
5	92995-08600	WASHER RONDELLE	6	6	6	6	
6	69P-41131-01-5B	MANIFOLD, EXT. 1 PIPE D'ECHAPPEMENT	1	1	1	1	
7	69P-41134-A0	GASKET, EXHAUST MANIFOLD JOINT, PIPE D'ECHAPPEMENT	1	1	1	1	
8	97880-06016	SCREW, PAN HEAD VIS, TETE TRONCONIQUE	4	4	4	4	
9	69P-41137-00-5B	GUIDE, EXHAUST COLLECTEUR D'ECHAPPEMENT	1	1	1	1	
10	97095-08020	BOLT BOULON	1	1	1	1	
11	92995-08600	WASHER RONDELLE	1	1	1	1	
12	69P-41138-00	SEAL, EXT. 1 JOINT DE GROUPE 1	1	1	1	1	
13	69P-41139-00	SEAL, EXT. 2 JOINT DE GROUPE 2	1	1	1	1	
14	6A8-41135-00	GASKET, EXHAUST MANIFOLD JOINT, PIPE D'ECHAPPEMENT	1	1	1	1	
15	91490-30025	PIN, COTTER GOUPILLE, FENDUE	1	1	1	1	
16	69P-47467-00-5B	PLATE, GUIDE PLAQUE, GUIDE	1	1	1	1	S
	69P-47467-10-5B	PLATE, GUIDE PLAQUE, GUIDE	1				L
17	69P-45127-00	SEAL JOINT	1	1	1	1	
18	69P-45128-00	SEAL 2 JOINT 2	1	1	1	1	
19	90119-06024	BOLT, WITH WASHER BOULON, AVEC RONDELLE	1	1	1	1	
20	69P-45159-00	DAMPER CAOUTCHOUC, JOINT	2				L

FIG. 20 LOWER CASING. DRIVE 1

BOITIER D'HELICE, TRANSMISSION 1

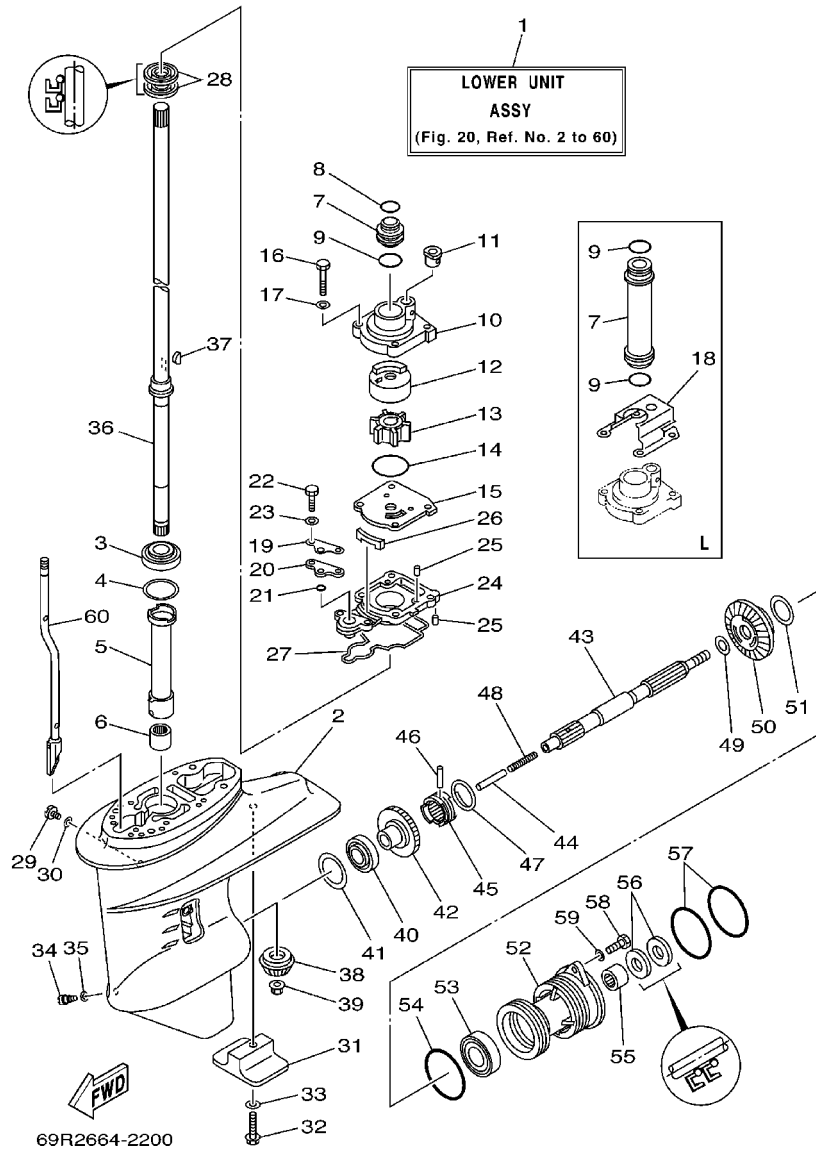

REF. NO.	PART NO. NO. PIECES	DESCRIPTION DESCRIPTION	25MH	30MH	25WC	30WC	REMARKS REMARQUES
1	69P-45300-00-4D	LOWER UNIT ASSY	1	1	1	1	S
	69P-45300-10-4D	LOWER UNIT ASSY	1				L
2	61N-45311-02-4D	CASING, LOWER	1	1	1	1	
		BOITIER D'HELICE					
3	93332-000W5	BEARING	1	1	1	1	
		ROULEMENT					
4	61N-45587-00-07	SHIM (T:0.7MM)	1	1	1	1	UR
		CALE(T:0.7MM)					
	61N-45587-00-10	SHIM (T:1.0MM)	1	1	1	1	UR
		CALE(T:1.0MM)					
	61N-45587-00-11	SHIM (T:1.1MM)	1	1	1	1	UR
		CALE(T:1.1MM)					
	61N-45587-00-12	SHIM (T:1.2MM)	1	1	1	1	UR
		CALE(T:1.2MM)					
	61N-45587-00-13	SHIM (T:1.3MM)	1	1	1	1	UR
		CALE(T:1.3MM)					
	61N-45587-00-14	SHIM (T:1.4MM)	1	1	1	1	UR
		CALE(T:1.4MM)					
	61N-45587-00-15	SHIM (T:1.5MM)	1	1	1	1	UR
		CALE(T:1.5MM)					
	61N-45587-00-16	SHIM (T:1.6MM)	1	1	1	1	UR
		CALE(T:1.6MM)					
5	61N-45536-00	SLEEVE, DRIVE SHAFT	1	1	1	1	
		MANCHON, ARBRE MOTEUR					
6	93315-220V7	BEARING	1	1	1	1	
		ROULEMENT					
7	61N-44362-00	TUBE, WATER	1	1	1	1	S
		TUBE D'EAU					
	61N-44362-10	TUBE, WATER	1				L
		TUBE D'EAU					
8	93210-22164	O-RING	1	1	1	1	S
		JOINT TORIQUE					
9	93210-26130	O-RING	1	1	1	1	S
		JOINT TORIQUE					
	93210-26130	O-RING	2				L
		JOINT TORIQUE					
10	69P-44311-00	HOUSING, WATER PUMP	1	1	1	1	
		CORPS, POMPE A EAU					
11	6L2-44367-00	DAMPER, WATER SEAL	1	1	1	1	
		JOINT TUBE D'EAU					
12	69P-44322-00	INSERT, CARTRIDGE	1				FOR STD
		CUVETTE					
	69P-44322-40	INSERT, CARTRIDGE	1	1	1	1	FOR CHROMATE
		CUVETTE					
13	6H4-44352-02	IMPELLER	1	1	1	1	
		TURBINE					
14	93210-45161	O-RING	1	1	1	1	
		JOINT TORIQUE					
15	61N-44323-00	OUTER PLATE, CARTRIDGE	1				FOR STD
		PLAQUE EXTERIEURE					
	61N-44323-40	OUTER PLATE, CARTRIDGE	1	1	1	1	FOR CHROMATE
		PLAQUE EXTERIEURE					

FIG. 20 LOWER CASING. DRIVE 1

BOITIER D'HELICE, TRANSMISSION 1

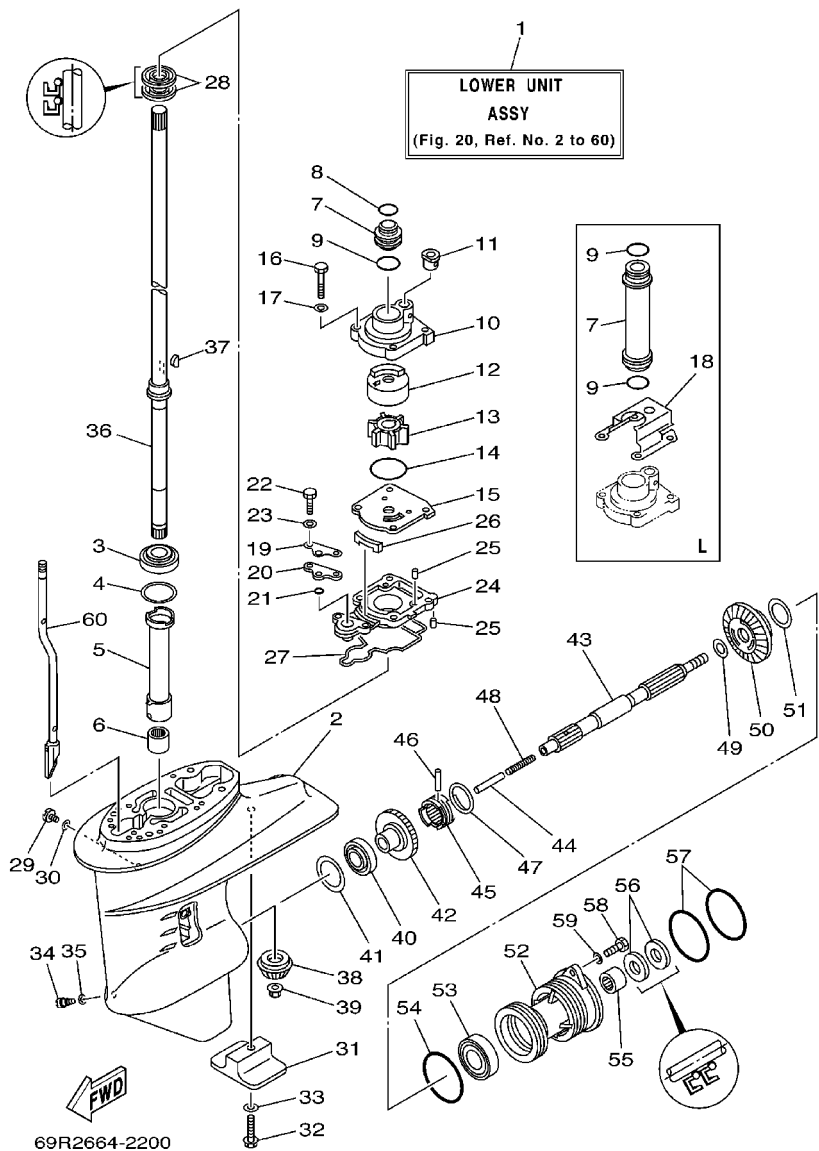

REF. NO.	PART NO. NO. PIECES	DESCRIPTION DESCRIPTION	25MH	30MH	25WC	30WC	REMARKS REMARQUES
16	97095-06040	BOLT BOULON	4	4	4	4	
17	92995-06600	WASHER RONDELLE	4	4	4	4	
18	65W-44328-11	PLATE PLAQUETTE	1				L
19	61N-44176-00	BRACKET SUPPORT	1	1	1	1	
20	61N-45321-00	PLATE PLAQUETTE	1	1	1	1	
21	93210-06ME6	O-RING JOINT TORIQUE	1	1	1	1	
22	97095-06025	BOLT BOULON	2	2	2	2	
23	92995-06600	WASHER RONDELLE	2	2	2	2	
24	61N-45331-00-5B	HOUSING, BEARING FLASQUE, ROULEMENT	1	1	1	1	
25	93604-10M03	PIN, DOWEL GOUJON	3	3	3	3	
26	61N-45127-00	SEAL JOINT	1	1	1	1	
27	61N-45315-00	PACKING, LOWER CASING JOINT, BOITIER D'HELICE	1	1	1	1	
28	93101-22067	OIL SEAL JOINT SPY	2	2	2	2	
29	90340-08002	PLUG, STRAIGHT SCREW PLOT, FILETE DROIT	1	1	1	1	
30	90430-08020	GASKET JOINT	1	1	1	1	
31	61N-45251-01	ANODE ANODE	1	1	1	1	
32	95895-06035	BOLT, FLANGE BOULON, A COLLERETTE	1	1	1	1	
33	92990-06300	WASHER, INTERNAL TOOTH RONDELLE, DENTURE INTERNE	1	1	1	1	
34	688-45341-10	PLUG, DRAIN BOUCHON DE VIDANGE	1	1	1	1	
35	90430-08020	GASKET JOINT	1	1	1	1	
36	61N-45510-00	DRIVE SHAFT ASSY ARBRE MOTEUR (ENS.)	1	1	1	1	S
	61N-45510-10	DRIVE SHAFT ASSY ARBRE MOTEUR (ENS.)	1				L
37	90280-03M03	KEY, WOODRUFF CLAVETTE, DEMI-LUNE	1	1	1	1	
38	61N-45551-00	PINION PIGNON D'ATTAQUE	1	1	1	1	
39	90179-10M14	NUT ECROU	1	1	1	1	
40	93332-00005	BEARING ROULEMENT	1	1	1	1	
41	6L2-45567-00-10	SHIM (T:1.0MM) CALE (T:1.0MM)	1	1	1	1	UR

FIG. 20 LOWER CASING. DRIVE 1

BOITIER D'HELICE, TRANSMISSION 1

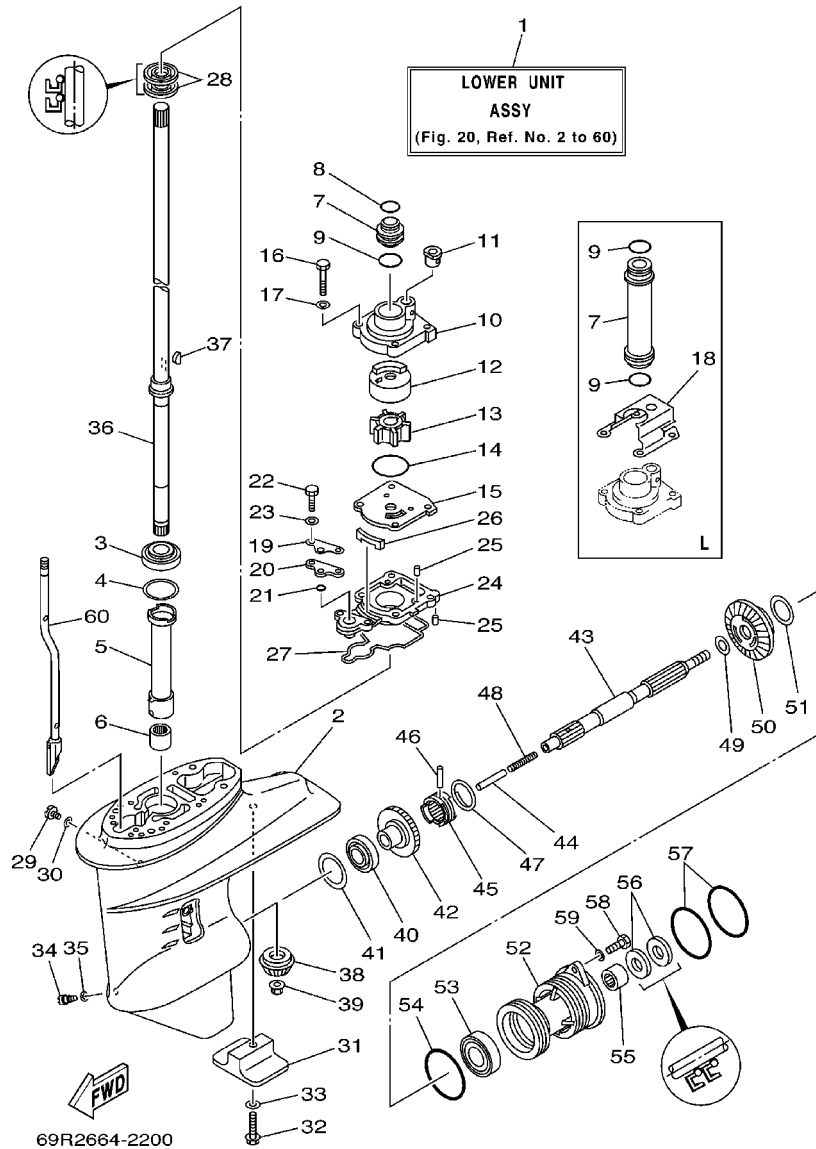

REF. NO.	PART NO. NO. PIECES	DESCRIPTION DESCRIPTION	25MH	30MH	25WC	30WC	REMARKS REMARQUES
41	6L2-45567-00-11	SHIM (T:1.1MM) CALE (T:1.1MM)	1	1	1	1	UR
	6L2-45567-00-12	SHIM (T:1.2MM) CALE (T:1.2MM)	1	1	1	1	UR
	6L2-45567-00-13	SHIM (T:1.3MM) CALE (T:1.3MM)	1	1	1	1	UR
	6L2-45567-00-14	SHIM (T:1.4MM) CALE (T:1.4MM)	1	1	1	1	UR
42	61N-45560-00	GEAR PIGNON	1	1	1	1	
43	6L2-45611-00	SHAFT, PROPELLER ARBRE, HELICE	1	1	1	1	
44	648-45635-00	PLUNGER, SHIFT POUSSOIR D'EMBRAYAGE	1	1	1	1	
45	664-45631-02	CLUTCH, DOG CRABOT	1	1	1	1	
46	90250-05010	PIN, STRAIGHT GOUPILLE, DROITE	1	1	1	1	
47	648-45633-00	RING, CROSS PIN JONC, GOUPILLE CRABOT	1	1	1	1	
48	90501-10065	SPRING, COMPRESSION RESSORT, COMPRESSION	1	1	1	1	
49	90201-20417	WASHER, PLATE RONDELLE, PLATE	1	1	1	1	
50	61N-45571-00	GEAR PIGNON	1	1	1	1	
51	6L2-45577-00-10	SHIM (T:1.0MM) CALE (T:1.0MM)	1	1	1	1	UR
	6L2-45577-00-11	SHIM (T:1.1MM) CALE (T:1.1MM)	1	1	1	1	UR
	6L2-45577-00-12	SHIM (T:1.2MM) CALE (T:1.2MM)	1	1	1	1	UR
	6L2-45577-00-13	SHIM (T:1.3MM) CALE (T:1.3MM)	1	1	1	1	UR
52	61N-45361-01-4D	CAP, LOWER CASING COUVERCLE, BOITIER D'HELICE	1	1	1	1	
53	93306-00612	BEARING ROULEMENT	1	1	1	1	
54	93210-64ME7	O-RING JOINT TORIQUE	1	1	1	1	
55	93315-22004	BEARING ROULEMENT	1	1	1	1	
56	93101-20M07	OIL SEAL JOINT SPY	2	2	2	2	
57	93210-65M50	O-RING JOINT TORIQUE	2	2	2	2	
58	97075-06020	BOLT BOULON	2	2	2	2	
59	92995-06600	WASHER RONDELLE	2	2	2	2	
60	61N-44150-00	SHIFT CAM ASSY CAME D'INVERSION	1	1	1	1	S
	61N-44150-10	SHIFT CAM ASSY CAME D'INVERSION	1				L

FIG. 21 LOWER CASING. DRIVE 2

BOITIER D'HELICE, TRANSMISSION 2

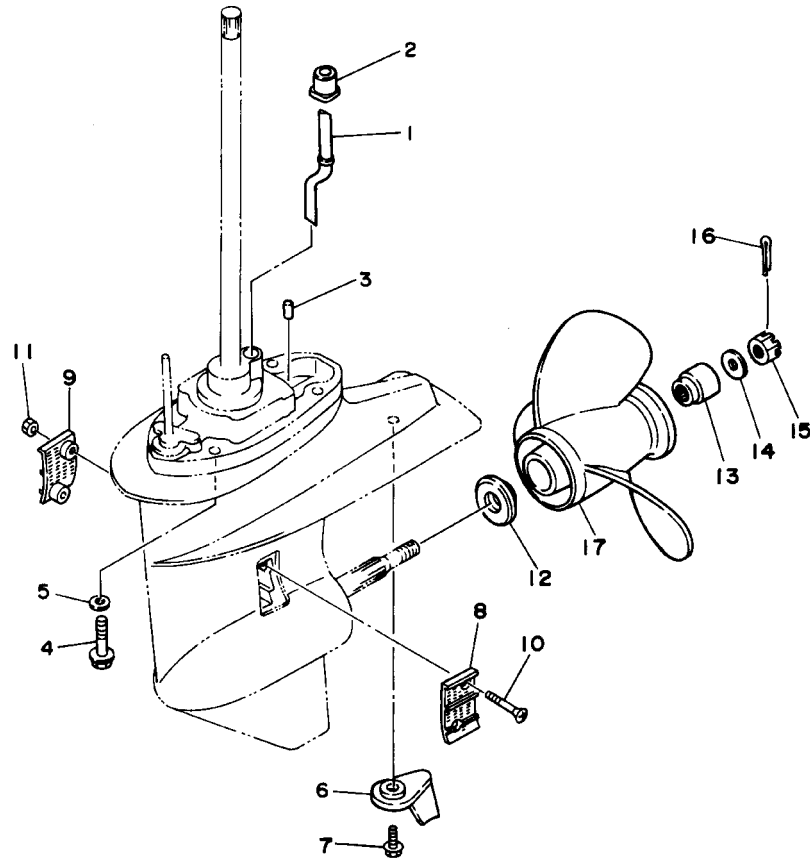

REF. NO.	PART NO. NO. PIECES	DESCRIPTION DESCRIPTION	25MH	30MH	25WC	30WC	REMARKS REMARQUES
1	61N-44361-00	TUBE, WATER TUBE D'EAU	1	1	1	1	S
	61N-44361-10	TUBE, WATER TUBE D'EAU	1				L
2	689-44366-00	DAMPER, WATER SEAL JOINT, TUBE D'EAU	1	1	1	1	
3	93606-11M24	PIN, DOWEL GOUJON	2	2	2	2	
4	90105-10M12	BOLT, FLANGE BOULON	4	4	4	4	
5	92995-10600	WASHER RONDELLE	4	4	4	4	
6	61N-45371-00	TAB-TRIM ANODE DERIVE	1	1	1	1	
7	90119-06M48	BOLT, WITH WASHER BOULON, AVEC RONDELLE	1	1	1	1	
8	6L2-45214-00	COVER, WATER INLET GRILLE, ENTREE D'EAU	1	1	1	1	
9	6L2-45215-00	COVER, WATER INLET GRILLE, ENTREE D'EAU	1	1	1	1	
10	90151-05M05	SCREW, COUNTERSUNK VIS, TETE NOYEE	2	2	2	2	
11	90185-05002	NUT, SELF-LOCKING ECROU, AUTO-BLOCANT	2	2	2	2	
12	6L2-45987-01	SPACER ENTRETOISE	1	1	1	1	
13	689-45997-00	SPACER ENTRETOISE	1	1	1	1	
14	92990-14200	WASHER, PLAIN RONDELLE, PLATE	1	1	1	1	
15	90171-14013	NUT, CASTLE ECROU, CRENELE	1	1	1	1	
16	91490-30022	PIN, COTTER GOUPILLE, FENDUE	1	1	1	1	
17	664-45941-01-EL	PROPELLER (3X9-7/8"X9"-F) HELICE (3X9-7/8"X9"-F)	1	1	1	1	UR
	664-45943-01-EL	PROPELLER (3X9-7/8"X8"-F) HELICE (3X9-7/8"X8"-F)	1	1	1	1	UR
	664-45945-00-EL	PROPELLER (3X9-7/8"X10-1/2"-F) HELICE (3X9-7/8"X10-1/2"-F)	1	1	1	1	UR
	664-45947-01-EL	PROPELLER (3X9-7/8"X11-1/4"-F) HELICE (3X9-7/8"X11-1/4"-F)	1	1	1	1	UR
	664-45949-02-EL	PROPELLER (3X9-7/8"X13"-F) HELICE (3X9-7/8"X13"-F)	1	1	1	1	UR
	664-45952-00-EL	PROPELLER (3X9-7/8"X14"-F) HELICE (3X9-7/8"X14"-F)	1	1	1	1	UR
	664-45954-01-EL	PROPELLER (3X9-7/8"X12"-F) HELICE (3X9-7/8"X12"-F)	1	1	1	1	UR
	62C-45941-00-EL	PROPELLER (3X9-7/8"X10"-F) HELICE (3X9-7/8"X10"-F)	1	1	1	1	UR



61R0010-4180

FIG. 22 FUEL TANK 1

RESERVOIR A CARBURANT 1

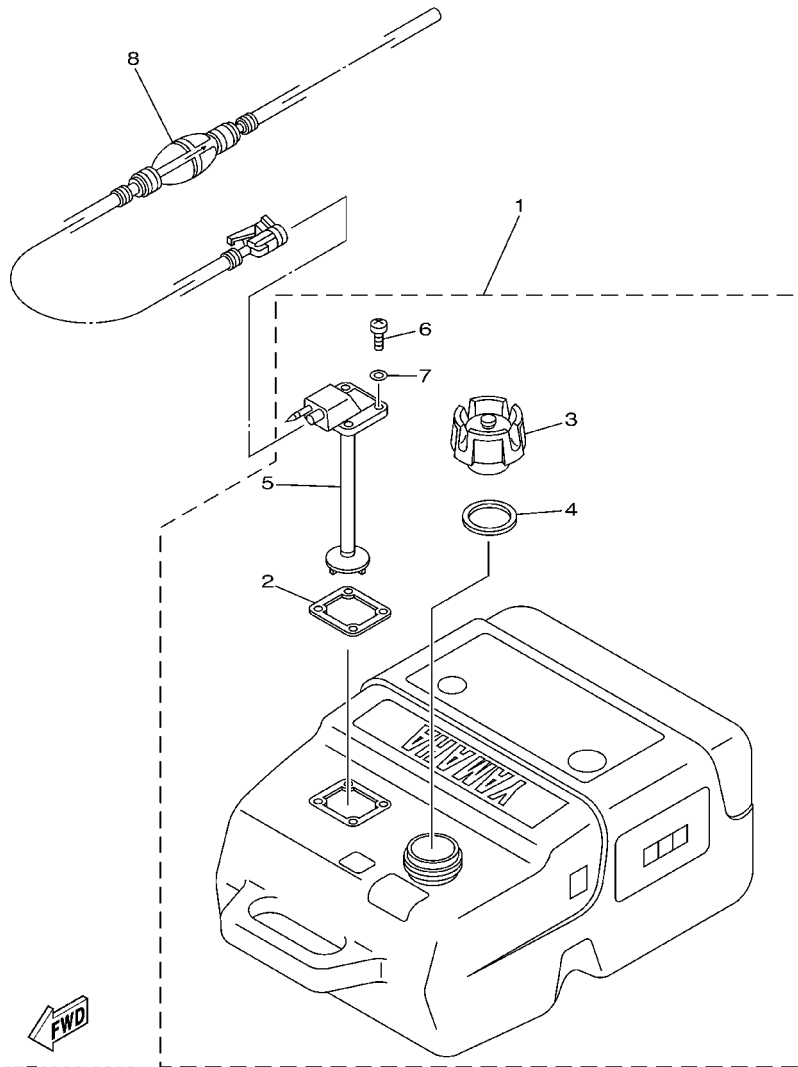

67F0300-9300

REF. NO.	PART NO. NO. PIECES	DESCRIPTION DESCRIPTION	25MH	30MH	25WC	30WC	REMARKS REMARQUES
1	6YK-24201-01	FUEL TANK ASSY RESERVOIR A ESSENCE (ENS.)	1				AP PLASTIC, 25L, "SCEPTER"
2	6YL-24268-01	.GASKET, FUEL METER .JOINT, JAUGE A CARBURANT	1				
3	6YK-24610-00	.CAP ASSY .BOUCHON	1				WITH INDICATOR
4	6YL-24641-00	.GASKET, CAP 1 .JOINT 1, BOUCHON	1				
5	6YK-24260-01	.FUEL METER ASSY .INDICATEUR DE CARBURANT	1				
6	90157-05M16	.SCREW, PAN HEAD .VIS, TETE TRONCONIQUE	4				
7	6YL-24329-00	.SEAL .JOINT	4				
8	6YL-24306-52	FUEL PIPE COMP. 1 DURITE A ESSENCE 1	1				AP

FIG. 23 FUEL TANK 2

RESERVOIR A CARBURANT 2

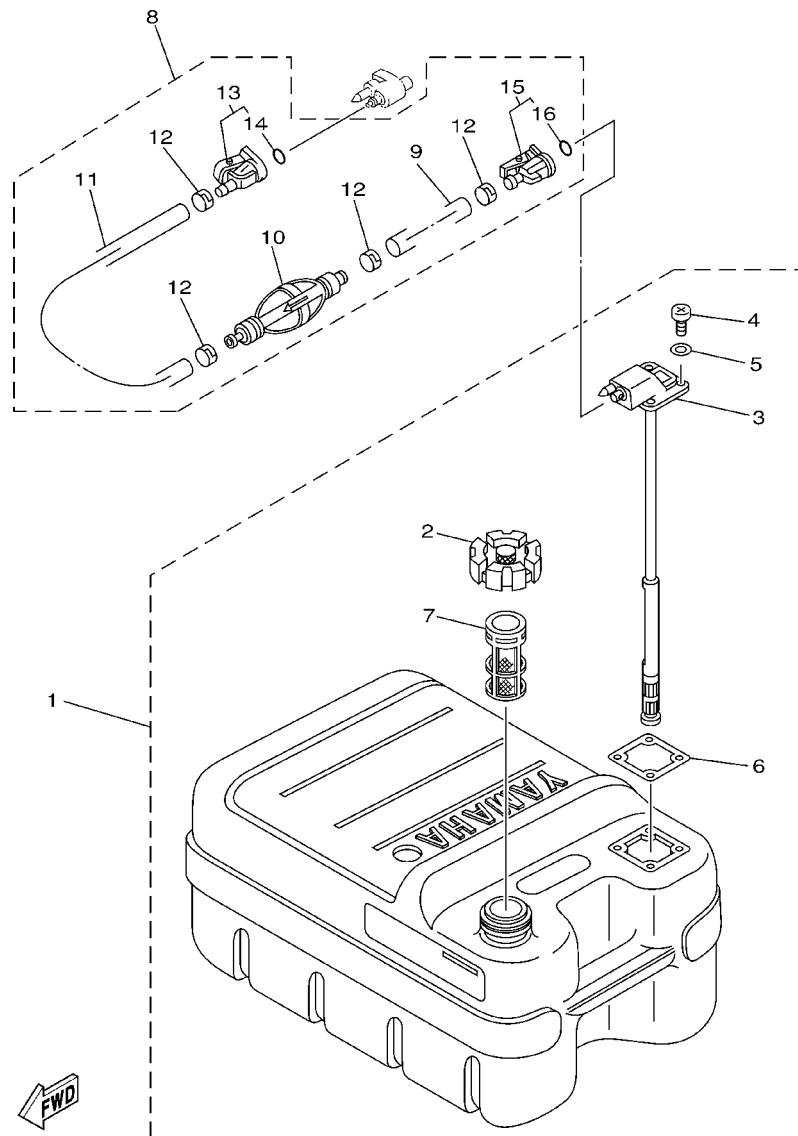

66T0100-9240

REF. NO.	PART NO. NO. PIECES	DESCRIPTION DESCRIPTION	25MH	30MH	25WC	30WC	REMARKS REMARQUES
1	6YJ-24201-00	FUEL TANK ASSY (24L) RESERVOIR A ESSENCE (ENS.):24L	1	1	1	1	AP FOR VOLGA
2	6YJ-24610-01	.CAP ASSY .BOUCHON	1	1	1	1	
3	6YJ-24260-00	.FUEL METER ASSY .INDICATEUR DE CARBURANT	1	1	1	1	
4	98586-05016	.SCREW, PAN HEAD .VIS, TETE TRONCONIQUE	4	4	4	4	
5	6Y1-24329-00	.SEAL .JOINT	4	4	4	4	
6	6Y1-24268-00	.GASKET, FUEL METER .JOINT, JAUGE A CARBURANT	1	1	1	1	
7	6YJ-24167-00	.STRAINER .FILTRE	1	1	1	1	
8	61J-24306-02	FUEL PIPE COMP. 1 DURITE A ESSENCE 1	1	1	1	1	AP FOR VOLGA
9	90445-11M06	.HOSE (L:2050) .DURITE (L:2050)	1	1	1	1	
10	61J-24360-00	.PRIMER PUMP ASSY .POMPE D'AMORCAGE	1	1	1	1	
11	90445-11M05	.HOSE (L:850) .DURITE (L:850)	1	1	1	1	
12	650-24351-51	.BAND 1 .COLLIER 1	4	4	4	4	
13	6G1-24305-03	.FUEL PIPE JOINT COMP. 2 .DURITE RACCORDEMT. A ESSENCE	1	1	1	1	
14	93210-08287	.O-RING ..JOINT TORIQUE	1	1	1	1	
15	6Y1-24305-04	.FUEL PIPE JOINT COMP. 2 .DURITE RACCORDEMT. A ESSENCE	1	1	1	1	
16	93210-08287	.O-RING ..JOINT TORIQUE	1	1	1	1	

FIG. 24 REMOTE CONTROL BOX

BOITIER DE COMMANDE A DISTANCE

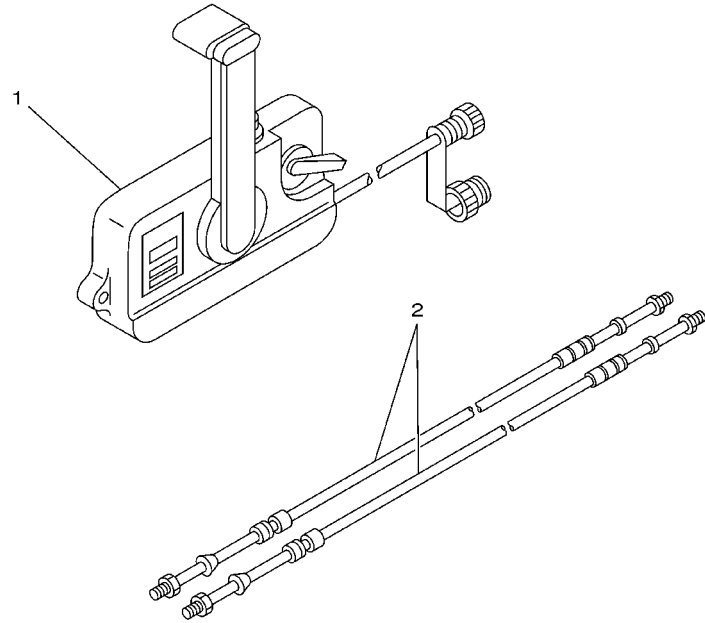

REF. NO.	PART NO. NO. PIECES	DESCRIPTION DESCRIPTION	25MH	30MH	25WC	30WC	REMARKS REMARQUES
1	701-48102-51	REMOTE CONTROL ASSY BOITIER DE COMMANDE A DISTANCE			1	1	AP
2	701-48320-50	CABLE, REMOTE CONTROL L=15F CABLE, COMMANDE A DISTANCE:15F			2	2	



63V0100-9220

FIG. 25 REMOTE CONTROL ASSY

BOITIER DE COMMANDE A DISTANCE

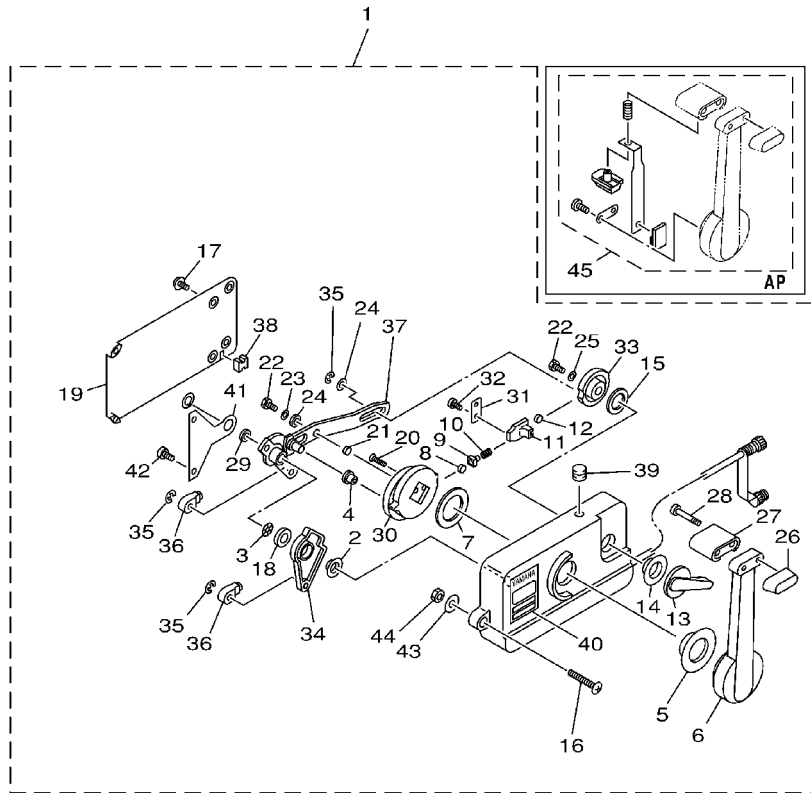

REF. NO.	PART NO. NO. PIECES	DESCRIPTION DESCRIPTION	25MH	30MH	25WC	30WC	REMARKS REMARQUES
1	701-48102-51	REMOTE CONTROL ASSY BOITIER DE COMMANDE A DISTANCE			1	1	AP
2	701-48235-00	.BUSHING .COUSSINET			1	1	
3	701-48197-10	.WASHER, WAVE .RONDELLE, ELASTIQUE ONDULEE			1	1	
4	701-48252-00	.ROLLER, CAM .POULIE			1	1	
5	701-48234-00	.BUSHING 1 .POULIE			1	1	
6	701-48221-00	.LEVER, CONTROL .LEVIER, COMMANDE			1	1	
7	701-48196-11	.WASHER, WAVE .RONDELLE, ELASTIQUE ONDULEE			1	1	
8	701-48236-00	.ROLLER, DETENT .POULIE			1	1	
9	702-48237-00	.ADAPTOR .ADAPTEUR			1	1	
10	702-48238-00	.SPRING, DETENT .RESSORT			1	1	
11	701-48249-00	.ADAPTOR, SPRING .ADAPTEUR			1	1	
12	701-48248-00	.ROLLER, FREE ACCEL. .POULIE			1	1	
13	701-48152-20	.KNOB, FREE ACCEL. .BOUTON			1	1	LEFT
14	701-48243-00	.BUSHING .COUSSINET			1	1	
15	701-48198-10	.WASHER, WAVE .RONDELLE, ELASTIQUE ONDULEE			1	1	
16	701-48281-10	.SCREW .VIS			3	3	
17	701-48289-00	.SCREW .VIS			4	4	
18	701-48268-00	.SPACER .ENTRETOISE			1	1	
19	701-48213-00	.BACK PLATE 2 .PLAQUETTE 2			1	1	
20	92780-06025	.SCREW, FLAT HEAD .VIS, TETE PLATE			2	2	
21	701-48255-00	.COLLAR .ENTRETOISE			1	1	
22	97390-06018	.BOLT .BOULON			2	2	
23	702-48288-00	.WASHER, PLAIN .RONDELLE, PLATE			1	1	
24	701-48246-00	.SPACER .ENTRETOISE			2	2	
25	92990-06300	.WASHER, INTERNAL TOOTH .RONDELLE, DENTURE INTERNE			1	1	
26	701-48229-00	.GRIP, CONTROL LEVER .POIGNEE, COMMANDE LEVIER			1	1	
27	701-48222-00	.GRIP, CONTROL LEVER .POIGNEE, COMMANDE LEVIER			1	1	

FIG. 25 REMOTE CONTROL ASSY

BOITIER DE COMMANDE A DISTANCE

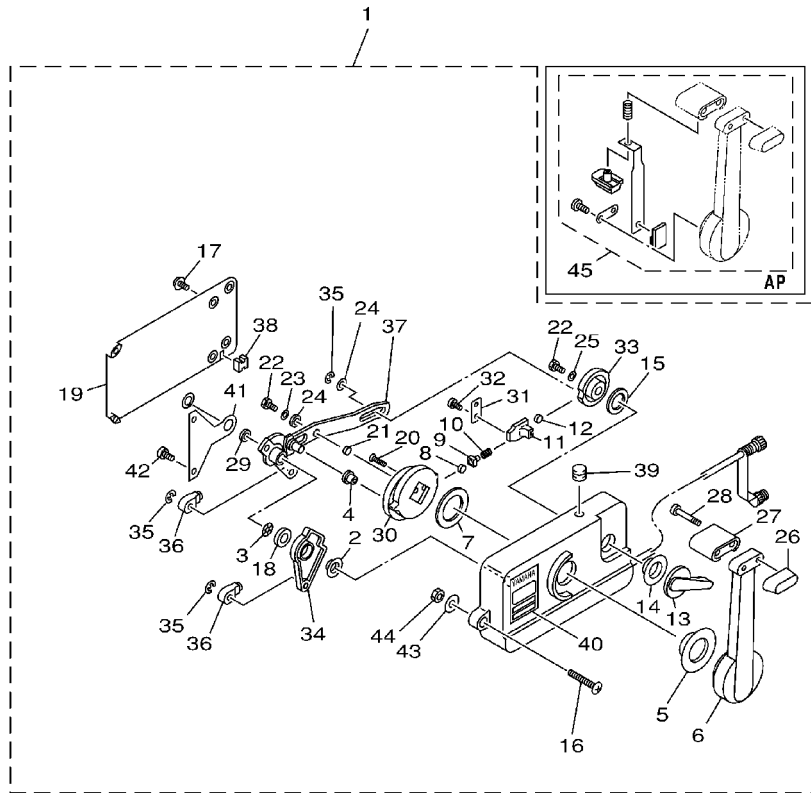

REF. NO.	PART NO. NO. PIECES	DESCRIPTION DESCRIPTION	25MH	30MH	25WC	30WC	REMARKS REMARQUES
28	701-48282-00	.SCREW .VIS			2	2	
29	701-48266-00	.SPACER .ENTRETOISE			1	1	
30	701-48232-00	.GEAR .PIGNON			1	1	
31	701-48189-11	.RETAINER .FLASQUE			1	1	
32	98580-05010	.SCREW, PAN HEAD .VIS, TETE TRONCONIQUE			2	2	
33	701-48153-12	.SHAFT, FREE ACCEL. .AXE			1	1	
34	701-48271-10	.ARM, SHIFT .BRAS			1	1	LEFT
35	93430-06024	.CIRCLIP .CIRCLIP, TYPE S			3	3	
36	703-48345-01	.CABLE END, REMOTE CONTROL 2 .CHAPE CABLE			2	2	
37	701-48261-10	.ARM, THROTTLE .BRAS, ACCELERATION			1	1	LEFT
38	701-48358-00	.ANCHOR, CABLE .COLLIER			1	1	
39	701-48138-50	.CAP, LOCK ARM .AMORTISSEUR			1	1	
40	701-48126-00	.GRAPHIC .ADHESIF			1	1	
41	701-48133-00	.PLATE, LINK .PLAQUE, BIELLETTE			1	1	
42	98580-05020	.SCREW, PAN HEAD .VIS, TETE TRONCONIQUE			2	2	
43	701-48287-00	.WASHER .RONDELLE			3	3	
44	95380-06600	.NUT, HEXAGON .ECROU			3	3	
45	701-48280-00	NEUTRAL LOCK KIT KIT DE VERROU NEUTRAL			1	1	AP



69R0300-1250

FIG. 26 SWITCH. PANEL

TABLEAU DE CONTACTEUR

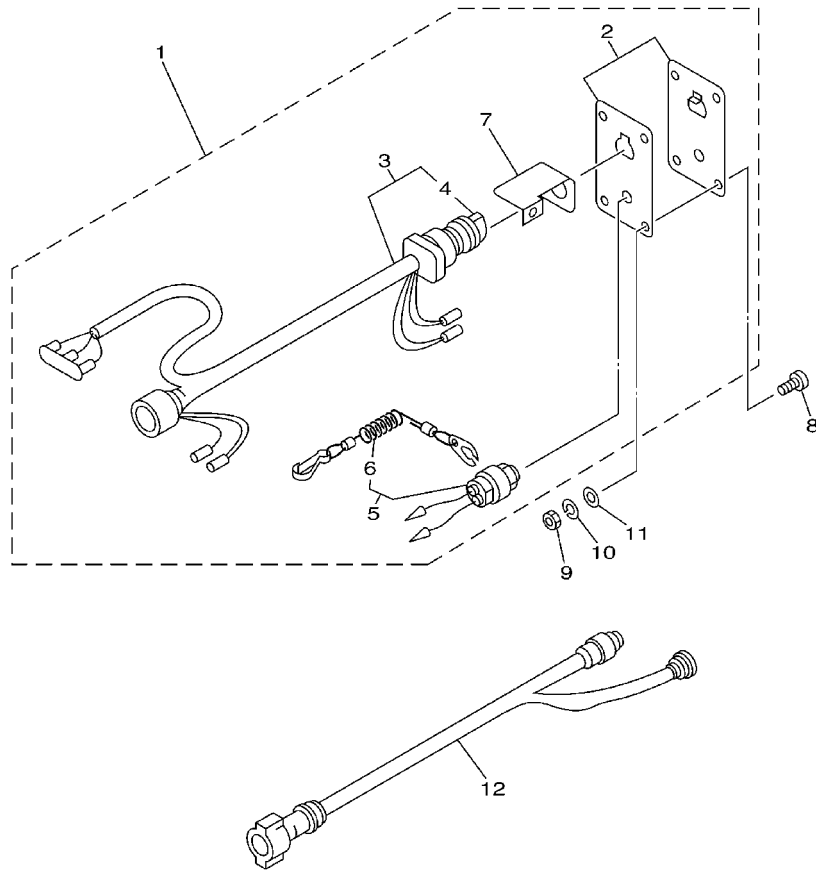

REF. NO.	PART NO. NO. PIECES	DESCRIPTION DESCRIPTION	25MH	30MH	25WC	30WC	REMARKS REMARQUES
1	689-82570-1A	PANEL SWITCH ASSY PLATINE D'INTERRUPEUR CPLT			1		AP
2	704-82571-01	.PANEL, SWITCH .TABLEAU, CONTACTEUR			1		
3	689-82510-04	.MAIN SWITCH ASSY .CONTACTEUR A CLEF COMPLET			1		
4	703-82577-00	..CAP, KEY ..CABOCHON			1		
5	688-82575-01	.ENGINE STOP SWITCH ASSY .COUPE CIRCUIT CPLT			1		
6	682-82556-00	..STOPPER ..PLAQUETTE			1		
7	64D-82581-00	.STAY, CORD CLAMP .SUPPORT, COLLIER DE CORDON			1		
8	90149-05M05	SCREW VIS			4		AP
9	95380-05600	NUT ECROU			4		AP
10	92990-05100	WASHER, SPRING RONDELLE, GROWER			4		AP
11	92990-05600	WASHER, PLATE RONDELLE, PLATE			4		AP
12	688-82586-50	EXTENSION, WIRE HARNESS EXTENSION, FAISCEAU DE FILS			1		AP L:5M(7P)



69R2300-2260

FIG. 27 REPAIR KIT 1

KITS DE REPARATION 1

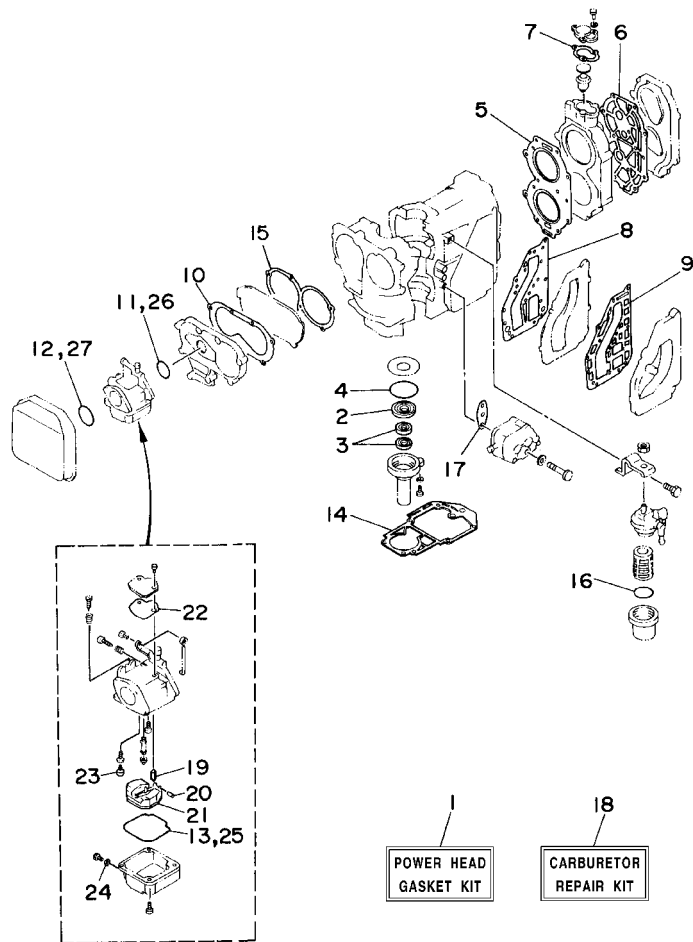

REF. NO.	PART NO. NO. PIECES	DESCRIPTION DESCRIPTION	25MH	30MH	25WC	30WC	REMARKS REMARQUES
1	69P-W0001-00	POWER HEAD GASKET KIT POCHETTE DE JINTS TETE MOTRICE	1	1	1	1	
2	93102-25008	.OIL SEAL .JOINT SPY	1	1	1	1	
3	93101-16001	.OIL SEAL .JOINT SPY	2	2	2	2	
4	93210-58M21	.O-RING .JOINT TORIQUE	1	1	1	1	
5	61N-11181-A1	.GASKET, CYLINDER HEAD 1 .JOINT, DE CULASSE 1	1	1	1	1	
6	61T-11193-A1	.GASKET, HEAD COVER 1 .JOINT, COUVERCLE DE CULASSE 1	1	1	1	1	
7	655-12414-A1	.GASKET, COVER .JOINT, COUVERCLE	1	1	1	1	
8	6K8-41122-A1	.GASKET, EXHAUST INNER COVER .JOINT, PLAQUE D'EHAPPEMENT	1	1	1	1	
9	6K8-41124-A1	.GASKET, EXHAUST OUTER COVER .JOINT, COUVERCLE D'ECHAPPEMEN	1	1	1	1	
10	648-13645-A0	.GASKET, MANIFOLD 1 .JOINT, TUBULURE 1	1	1	1	1	
11	61N-14198-00	.GASKET .JOINT	1	1	1	1	
12	93210-40659	.O-RING .JOINT TORIQUE	1	1	1	1	
13	6L2-14384-00	.GASKET, FLOAT CHAMBER .JOINT, CUVE DE FLOTTEUR	1	1	1	1	
14	689-45113-A1	.GASKET, UPPER CASING .JOINT, TUBE D'ARBRE	1	1	1	1	
15	648-13621-A1	.GASKET, VALVE SEAT .JOINT, SIEGE DE CLAPET	1	1	1	1	
16	93210-32738	.O-RING .JOINT TORIQUE	1	1	1	1	
17	650-24431-A0	.GASKET, FUEL PUMP 1 .JOINT 1 DE POMPE A ESSENCE	1	1	1	1	
18	61N-W0093-00	CARBURETOR REPAIR KIT KIT DE REPARATION CARBURATEUR	1	1	1	1	
19	61N-14392-00	.VALVE, NEEDLE .POINTEAU	1	1	1	1	
20	6E5-14386-01	.PIN, FLOAT .AXE, FLOTTEUR	1	1	1	1	
21	6L2-14385-00	.FLOAT .FLOTTEUR	1	1	1	1	
22	6L2-14399-00	.GASKET .JOINT	1	1	1	1	
23	50M-14355-00	.PLUG .PLOT	1	1	1	1	
24	6L2-14398-00	.GASKET .JOINT	1	1	1	1	
25	6L2-14384-00	.GASKET, FLOAT CHAMBER .JOINT, CUVE DE FLOTTEUR	1	1	1	1	
26	61N-14198-00	.GASKET .JOINT	1	1	1	1	
27	93210-40659	.O-RING .JOINT TORIQUE	1	1	1	1	

61R0700-4180

FIG. 28 REPAIR KIT 2

KITS DE REPARATION 2

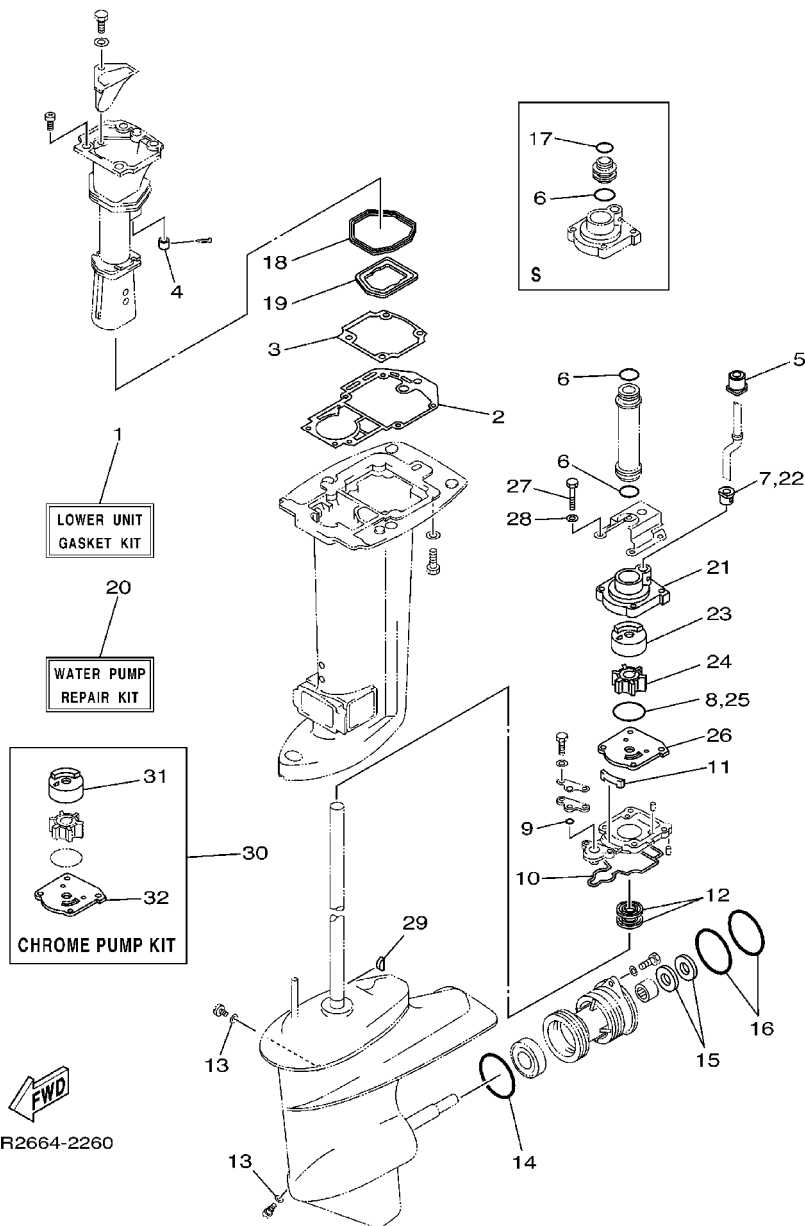

REF. NO.	PART NO. NO. PIECES	DESCRIPTION DESCRIPTION	25MH	30MH	25WC	30WC	REMARKS REMARQUES
1	69P-W0001-20	LOWER UNIT GASKET KIT POCHETTE DE JOINTS EMBASE	1	1	1	1	
2	689-45113-A1	.GASKET, UPPER CASING .JOINT, TUBE D'ARBRE	1	1	1	1	
3	69P-41134-A0	.GASKET, EXHAUST MANIFOLD .JOINT, PIPE D'ECHAPPEMENT	1	1	1	1	
4	6A8-41135-00	.GASKET, EXHAUST MANIFOLD .JOINT, PIPE D'ECHAPPEMENT	1	1	1	1	
5	689-44366-00	.DAMPER, WATER SEAL .JOINT, TUBE D'EAU	1	1	1	1	
6	93210-26130	.O-RING .JOINT TORIQUE	3	3	3	3	UN
7	6L2-44367-00	.DAMPER, WATER SEAL .JOINT TUBE D'EAU	1	1	1	1	
8	93210-45161	.O-RING .JOINT TORIQUE	1	1	1	1	
9	93210-06ME6	.O-RING .JOINT TORIQUE	1	1	1	1	
10	61N-45315-00	.PACKING, LOWER CASING .JOINT, BOITIER D'HELICE	1	1	1	1	
11	61N-45127-00	.SEAL .JOINT	1	1	1	1	
12	93101-22067	.OIL SEAL .JOINT SPY	2	2	2	2	
13	90430-08020	.GASKET .JOINT	2	2	2	2	
14	93210-64ME7	.O-RING .JOINT TORIQUE	1	1	1	1	
15	93101-20M07	.OIL SEAL .JOINT SPY	2	2	2	2	
16	93210-65M50	.O-RING .JOINT TORIQUE	2	2	2	2	
17	93210-22164	.O-RING .JOINT TORIQUE	1	1	1	1	S
18	69P-41138-00	.SEAL, EXT. 1 .JOINT DE GROUPE 1	1	1	1	1	
19	69P-41139-00	.SEAL, EXT. 2 .JOINT DE GROUPE 2	1	1	1	1	
20	69P-W0078-00	WATER PUMP REPAIR KIT KIT DE REPARATION DE LA POMPE	1	1	1	1	
21	69P-44311-00	.HOUSING, WATER PUMP .CORPS, POMPE A EAU	1	1	1	1	
22	6L2-44367-00	.DAMPER, WATER SEAL .JOINT TUBE D'EAU	1	1	1	1	
23	69P-44322-00	.INSERT, CARTRIDGE .CUVETTE	1	1	1	1	
24	6H4-44352-02	.IMPELLER .TURBINE	1	1	1	1	
25	93210-45161	.O-RING .JOINT TORIQUE	1	1	1	1	
26	61N-44323-00	.OUTER PLATE, CARTRIDGE .PLAQUE EXTERIEURE	1	1	1	1	
27	97095-06040	.BOLT .BOULON	4	4	4	4	

FIG. 28 REPAIR KIT 2

KITS DE REPARATION 2

REF. NO.	PART NO. NO. PIECES	DESCRIPTION DESCRIPTION	25MH	30MH	25WC	30WC	REMARKS REMARQUES
28	92995-06600	.WASHER .RONDELLE	4	4	4	4	
29	90280-03M03	.KEY, WOODRUFF .CLAVETTE, DEMI-LUNE	1	1	1	1	
30	69P-W0078-0A	CHROME PUMP KIT KIT DE POMPE A EAU CHROMEE	1	1	1	1	
31	69P-44322-40	.INSERT, CARTRIDGE .CUVETTE	1	1	1	1	
32	61N-44323-40	.OUTER PLATE, CARTRIDGE .PLAQUE EXTERIEURE	1	1	1	1	

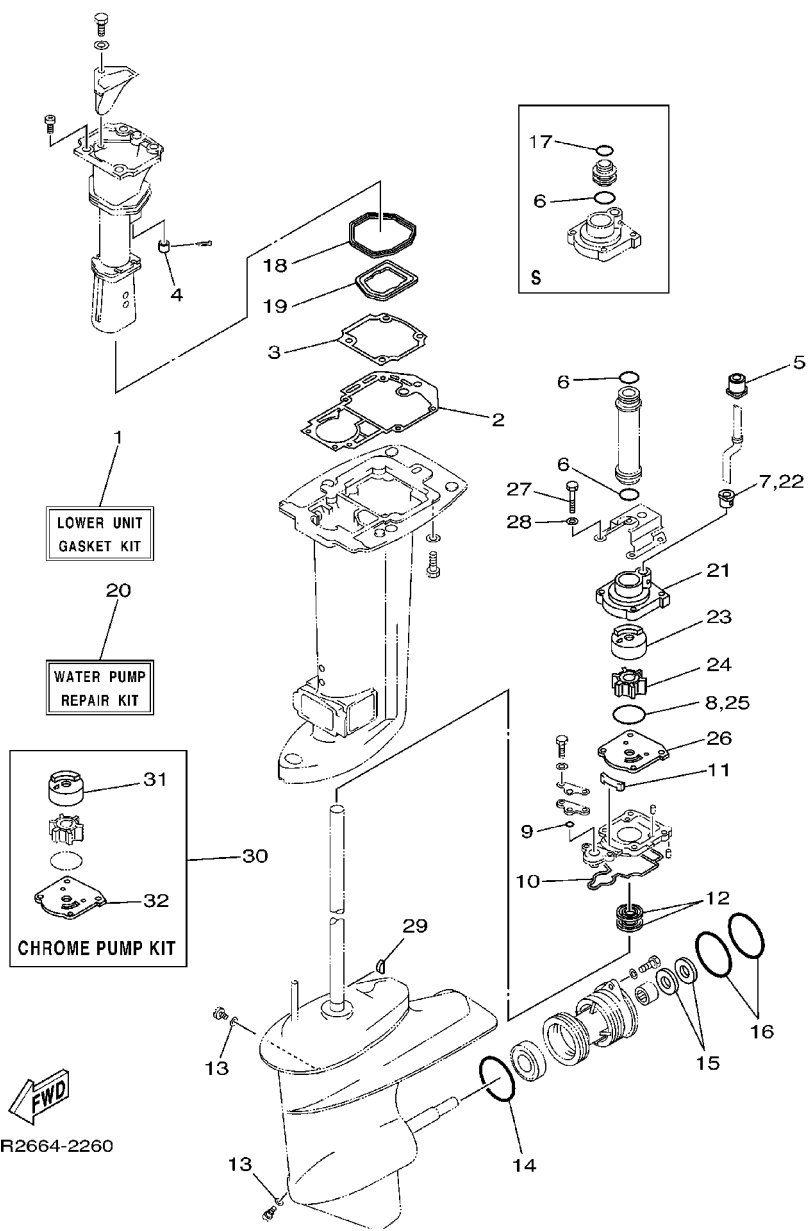

NUMERICAL INDEX
INDEX NUMERIQUE

PART NO. NO. PIECES	REF. NO.	PART NO. NO. PIECES	REF. NO.	PART NO. NO. PIECES	REF. NO.	PART NO. NO. PIECES	REF. NO.	PART NO. NO. PIECES	REF. NO.	PART NO. NO. PIECES	REF. NO.
69P-W0001-00	27-1	648-13621-A1	27-15	61N-15734-00	7-7	61N-24560-00	6-7	656-42153-00-94	15-15	689-43160-00	17-18
69P-W0001-20	28-1	61N-13641-01-1S	4-4	6F5-15739-00	7-16	61N-24563-00	6-8	69P-42154-00	15-21	689-43165-00	17-19
689-W0004-00	4-2	648-13645-A0	4-5	6F5-15741-01	7-4	61N-24566-01	6-12	69P-42157-00-94	15-14	689-43191-00	17-13
61R-W0070-10	1-11		27-10	69P-15746-00	7-41	6YJ-24610-01	23-2	69P-42167-00	15-19	689-43192-01	17-14
69P-W0078-0A	28-30	6L2-14157-00	5-7	689-15747-70	7-42	6YK-24610-00	22-3	62Y-42171-00	15-22	689-43311-03-4D	17-26
69P-W0078-00	28-20	61N-14198-00	4-12	656-15748-00	7-37	6YL-24641-00	22-4	6F6-42177-A0	14-13	682-43318-01	17-43
69P-W0084-00-4D	14-1		27-11	6G0-15754-00	7-9	61N-26311-00	14-24	69P-42511-00-4D	18-4	689-43373-01	18-2
69P-W0090-00-1S	2-1		27-26	689-15755-01	7-14	61N-26326-00	13-17	689-42521-00-94	18-7	689-43614-01	17-37
69S-W0090-00-1S	2-1	61N-14212-00	5-21	61N-15758-01-4D	7-18	6A1-28176-00	13-25	647-42523-00	13-16	648-43615-00	17-38
61N-W0093-00	27-18	646-14212-01	5-18	61N-15762-00	7-19	6K8-41121-00-1S	2-31	682-42525-00	11-19	689-43616-00	17-32
61N-W1571-11	7-1	69P-14301-00	5-1	6F5-15764-00	7-15	6K8-41122-A1	2-32	648-42528-00	18-1	648-43617-00	17-35
656-W2810-02	6-33	69S-14301-00	5-1	61T-15770-00	7-36		27-8	624-42542-00	9-7	689-43631-00	17-29
61N-11111-01-1S	2-19	664-14321-01	5-13	6H7-15771-01-94	7-29	61N-41123-00-1S	2-33	69R-42610-20-4D	1-1	689-43633-00	17-30
61T-11111-01-1S	2-19	61N-14323-00	5-19	61T-15772-01-94	7-31	6K8-41124-A1	2-36	69R-42610-30-4D	1-1	648-43642-00	17-33
61N-11181-A1	2-21	6A0-14325-00	6-26	656-15772-00-94	7-31		27-9	69S-42610-20-4D	1-1	689-43643-00	17-31
	27-5	61N-14341-00	5-9	69P-15774-00	7-39	69P-41131-01-5B	19-6	69P-42613-00-4D	1-7	689-43681-01	17-42
61N-11191-01-1S	2-22	61T-14341-00	5-9	6F5-15779-02	7-17	69P-41134-A0	19-7	6G0-42615-00	1-2	689-44111-01-4D	15-30
61T-11193-A1	2-23	6L2-14342-34	5-11	6A0-15789-00	7-22		28-3	61N-42628-00	1-10	664-44113-01	15-31
	27-6	61N-14343-65	5-10	6YJ-24167-00	23-7	6A8-41135-00	19-14	689-42647-00	1-3	689-44121-01	15-38
6J8-11325-00	2-12	50M-14355-00	5-12	6YJ-24201-00	23-1		28-4	6G0-42651-02	1-5	689-44125-00	15-39
689-11325-00	2-17		27-23	6YK-24201-01	22-1	69P-41137-00-5B	19-9	69R-42677-00	1-12	664-44142-00	15-33
6H3-11327-00-1S	2-13	61N-14381-00	5-2	6YJ-24260-00	23-3	69P-41138-00	19-12	69S-42677-00	1-12	61N-44143-00	15-43
6H3-11328-00	2-14	677-14383-01	5-15	6YK-24260-01	22-5		28-18	69S-42677-C0	1-12	61N-44146-00	15-47
676-11372-00	2-20	6L2-14384-00	5-20	6YL-24268-01	22-2	69P-41139-00	19-13	61R-42678-10	1-13	61N-44150-00	20-60
	2-34		27-13	6Y1-24268-00	23-6		28-19	61T-42678-10	1-13	61N-44150-10	20-60
69P-11400-00	3-1		27-25	6G1-24304-02	6-1	69P-41213-00	15-18	689-42711-04-4D	13-1	664-44167-01	15-27
69P-11412-00	3-2	6L2-14385-00	5-5	6G1-24305-03	23-13	662-41237-01	15-7	664-42715-00	15-26	61N-44176-00	20-19
61N-11422-00	3-3		27-21	6Y1-24305-04	23-15	682-41237-00	15-12	69P-42716-00	18-25	6E0-44191-11	1-14
61N-11432-00	3-4	6E5-14386-01	5-4	6YL-24306-52	22-8	682-41238-01	15-11	65W-42717-00	19-2	61N-44194-01	9-2
61N-11442-00	3-5		27-20	61J-24306-02	23-8	679-41241-01	15-9	69P-42717-00	18-24	61T-44194-01	9-2
61N-11515-00	3-10	61N-14392-00	5-3	6A1-24311-00	6-31	69P-41241-00	15-20	689-42718-00	18-21	69P-44311-00	20-10
61N-11603-00	3-19		27-19	689-24311-00	6-14	689-41252-01	4-20	682-42724-00	13-14		28-21
61N-11604-00	3-19	6L2-14398-00	5-16	6YL-24329-00	22-7	61N-41256-00	4-21	689-42724-50	11-16	69P-44322-00	20-12
61N-11605-00	3-19		27-24	6Y1-24329-00	23-5	661-41262-02	4-22	689-42725-01	13-15		28-23
61N-11631-00-95	3-18	6L2-14399-00	5-8	61N-24329-00	6-2	682-41271-00	4-17	6E7-42791-00	13-23	69P-44322-40	20-12
689-11633-00	3-20		27-22	650-24351-51	23-12	689-41273-00	4-18	6E7-42791-10	13-23		28-31
688-11634-00	3-22	61N-14440-00	4-13	61J-24360-00	23-10	6J8-41274-00	4-19	6G5-42791-00	13-23	61N-44323-00	20-15
61N-11635-00	3-18	69P-14497-00	15-1	692-24410-00	6-16	676-41611-00	8-17	6A1-42792-01	13-24		28-26
61N-11636-00	3-18	62Y-14597-00	5-23	663-24411-00	6-21	689-41612-01	8-21	6G0-42796-00	13-5	61N-44323-40	20-15
689-11651-00	3-12	69P-15100-00-1S	2-2	692-24411-00	6-18	676-41613-00	8-18	689-42815-00	13-9		28-32
689-11681-01	3-13	689-15396-01-5B	2-6	6A0-24412-02	6-27	61N-41615-00	9-1	689-42816-00	13-12	65W-44328-11	20-18
6E5-12411-01	2-26	61N-15711-10	7-2	6A0-24413-00	6-17	69P-41631-00	15-2	689-43111-03-4D	17-1	6H4-44352-02	20-13
655-12413-01-1S	2-28	6F5-15713-01	7-5	6A0-24421-01	6-25	689-42111-01-4D	14-2	689-43112-02-4D	17-2		28-24
655-12414-A1	2-29	6G0-15714-01	7-3	650-24431-A0	6-28	69P-42112-00-4D	14-7	6J8-43113-01	17-12	61N-44361-00	21-1
	27-7	61N-15715-00	7-6		27-17	664-42119-00	14-12	648-43114-01	17-6	61N-44361-10	21-1
61N-13610-00	4-1	6F5-15716-01	7-8	648-24434-01	6-19	656-42126-01	14-21	6E0-43118-01	17-3	61N-44362-00	20-7
689-13610-01	4-1	6F5-15723-01	7-34	648-24435-02	6-22	6G1-42137-10	14-15	6J8-43131-01	17-7	61N-44362-10	20-7
648-13621-A1	4-3	6F5-15726-01	7-11	61N-24521-00	6-9	689-42138-00	14-20	6G5-43145-01	17-8	689-44366-00	21-2

NUMERICAL INDEX
INDEX NUMERIQUE

PART NO. NO. PIECES	REF. NO.	PART NO. NO. PIECES	REF. NO.	PART NO. NO. PIECES	REF. NO.	PART NO. NO. PIECES	REF. NO.	PART NO. NO. PIECES	REF. NO.	PART NO. NO. PIECES	REF. NO.
689-44366-00	28 - 5	6L2-45567-00-11	20 - 41	701-48232-00	25 - 30	689-81840-11	12 - 10	69P-85541-09	8 - 3	90151-05M05	21 - 10
6L2-44367-00	20 - 11	6L2-45567-00-12	20 - 41	701-48234-00	25 - 5	689-81847-11	12 - 6	61N-85542-00-94	9 - 5	90151-06M02	2 - 18
	28 - 7	6L2-45567-00-13	20 - 41	701-48235-00	25 - 2	689-81850-12	12 - 8	61N-85543-09	8 - 5	90157-05M16	22 - 6
	28 - 22	6L2-45567-00-14	20 - 41	701-48236-00	25 - 8	689-81857-11	12 - 2	61N-85543-19	8 - 6	90161-06M00	11 - 20
664-44514-00-94	18 - 35	61N-45571-00	20 - 50	702-48237-00	25 - 9	69R-81915-00	10 - 2	61N-85550-10	8 - 1	90170-10M42	18 - 27
689-44516-00	18 - 30	6L2-45577-00-10	20 - 51	702-48238-00	25 - 10	6H3-81922-00	9 - 18	61T-85550-10	8 - 1		18 - 33
69P-44518-00-94	18 - 14	6L2-45577-00-11	20 - 51	701-48243-00	25 - 14	6G1-81941-10	11 - 2	69P-85560-00	8 - 2	90171-14013	21 - 15
648-44519-00-94	18 - 16	6L2-45577-00-12	20 - 51	701-48246-00	25 - 24	61T-81945-01	11 - 4	69P-85561-00	8 - 10	90176-10M01	18 - 38
689-44551-01-4D	18 - 43	6L2-45577-00-13	20 - 51	701-48248-00	25 - 12	6G1-81952-00	11 - 3	6H5-85570-00	9 - 20	90179-06M24	1 - 8
689-44552-01-4D	18 - 45	61N-45587-00-07	20 - 4	701-48249-00	25 - 11	6J8-81960-00	10 - 1	61N-85570-00	9 - 20	90179-10M14	20 - 39
689-44553-00-94	18 - 39	61N-45587-00-10	20 - 4	701-48252-00	25 - 4	664-81970-61	11 - 6		9 - 25	90179-16M05	8 - 15
689-44555-00	18 - 44	61N-45587-00-11	20 - 4	701-48255-00	25 - 21	689-82105-13	11 - 15	61N-85570-10	9 - 25	90185-05002	21 - 11
689-44557-00	18 - 40	61N-45587-00-12	20 - 4	701-48261-10	25 - 37	682-82150-10	11 - 11	61T-86111-00	11 - 21	90185-06062	14 - 23
648-44591-A0	18 - 29	61N-45587-00-13	20 - 4	701-48266-00	25 - 29	682-82151-00	11 - 12	61T-86112-00	11 - 24	90185-22043	17 - 9
	18 - 34	61N-45587-00-14	20 - 4	701-48268-00	25 - 18	61N-82317-00	9 - 6	682-86116-00	11 - 22	90201-06M30	9 - 9
	18 - 36	61N-45587-00-15	20 - 4	701-48271-10	25 - 34	6G1-82370-21	9 - 29	682-86117-00	11 - 23	90201-06416	15 - 5
69P-45111-00-4D	19 - 1	61N-45587-00-16	20 - 4	701-48280-00	25 - 45	663-82370-01	9 - 29	90101-08339	17 - 22	90201-08M87	13 - 4
69P-45111-10-4D	19 - 1	6L2-45611-00	20 - 43	701-48281-10	25 - 16	689-82510-04	26 - 3	90105-06M07	15 - 32	90201-16M44	8 - 16
689-45113-A1	2 - 41	664-45631-02	20 - 45	701-48282-00	25 - 28	61N-82519-01	9 - 10		18 - 6	90201-20M27	3 - 23
	27 - 14	648-45633-00	20 - 47	701-48287-00	25 - 43	689-82531-02	11 - 5	90105-06M08	18 - 26	90201-20417	20 - 49
	28 - 2	648-45635-00	20 - 44	702-48288-00	25 - 23	689-82540-01	11 - 30	90105-06M18	18 - 3	90201-21567	2 - 27
663-45119-00	17 - 17	62C-45941-00-EL	21 - 17	701-48289-00	25 - 17	69R-82553-00	10 - 5	90105-08M10	7 - 35	90201-22M03	17 - 10
	17 - 28	664-45941-01-EL	21 - 17	701-48320-50	24 - 2	682-82556-00	13 - 19	90105-10M12	21 - 4	90201-28013	14 - 5
	18 - 23	664-45943-01-EL	21 - 17	648-48330-50	16 - 16		26 - 6	90109-06M18	17 - 44	90201-50306	2 - 40
61N-45127-00	20 - 26	664-45945-00-EL	21 - 17	617-48331-91	16 - 17	6E3-8257H-00	13 - 26	90119-06MA0	2 - 39	90202-06007	15 - 35
	28 - 11	664-45947-01-EL	21 - 17	648-48340-50	16 - 10	689-8257Y-00	13 - 20	90119-06MA2	2 - 24		15 - 44
69P-45127-00	19 - 17	664-45949-02-EL	21 - 17	703-48345-01	25 - 36	689-82570-1A	26 - 1		2 - 30	90202-10024	15 - 41
69P-45128-00	19 - 18	664-45952-00-EL	21 - 17	617-48346-90	16 - 12	704-82571-01	26 - 2	90119-06MA3	2 - 37	90206-05005	7 - 45
69P-45159-00	19 - 20	664-45954-01-EL	21 - 17	648-48346-50	16 - 18	6E9-82575-02	13 - 18		7 - 30	90206-12052	13 - 10
6L2-45214-00	21 - 8	6L2-45987-01	21 - 12	701-48358-00	25 - 38	688-82575-01	26 - 5		7 - 32	90206-28001	14 - 6
6L2-45215-00	21 - 9	689-45997-00	21 - 13	617-48361-91	16 - 11	703-82577-00	26 - 4	90119-06MA4	2 - 38	90209-24M03	3 - 15
61N-45251-01	20 - 31	69P-47467-00-5B	19 - 16	700-48510-12	16 - 22	61T-82580-00	11 - 13		7 - 32	90209-47016	18 - 9
69P-45300-00-4D	20 - 1	69P-47467-10-5B	19 - 16	689-48531-50	16 - 7	64D-82581-00	26 - 7	90119-06M17	15 - 25	90240-05047	17 - 39
69P-45300-10-4D	20 - 1	701-48102-51	24 - 1	689-48532-50	16 - 4	6E5-82582-00	10 - 4	90119-06M23	7 - 43	90243-04M01	17 - 4
61N-45311-02-4D	20 - 2		25 - 1	648-48534-50-4D	16 - 1	688-82586-50	26 - 12	90119-06M48	21 - 7	90249-06M22	17 - 34
61N-45315-00	20 - 27	701-48126-00	25 - 40	61N-81313-09	8 - 4	61T-82590-00	11 - 14	90119-06M73	13 - 13	90250-05010	20 - 46
	28 - 10	701-48133-00	25 - 41	6E9-81328-70	8 - 7	689-82594-10	11 - 18	90119-06M94	4 - 15	90266-04M00	1 - 6
		701-48138-50	25 - 39	689-81800-13	12 - 1	6A1-83625-41	4 - 25	90119-06M95	9 - 8	90266-04M01	1 - 4
61N-45321-00	20 - 20	701-48152-20	25 - 13	689-81809-11	12 - 7	6A1-83625-51	4 - 26	90119-06024	19 - 19	90269-02M09	14 - 16
61N-45331-00-5B	20 - 24	701-48153-12	25 - 33	689-81810-11	12 - 9	61T-83625-80	4 - 26	90119-06025	7 - 33	90280-03M03	20 - 37
688-45341-10	20 - 34	701-48189-11	25 - 31	689-81811-11	12 - 12	6E0-83627-41	14 - 26	90119-06026	10 - 7		28 - 29
61N-45361-01-4D	20 - 52	701-48196-11	25 - 7	689-81812-11	12 - 11	6E0-83627-51	14 - 25	90119-08M03	18 - 47	90280-05015	8 - 14
61N-45371-00	21 - 6	701-48197-10	25 - 3	689-81813-10	12 - 13	61T-83627-80	14 - 25	90119-08M65	2 - 4	90340-08002	20 - 29
61N-45510-00	20 - 36	701-48198-10	25 - 15	689-81820-11	12 - 14	682-84381-00	13 - 22	90119-08009	2 - 3	90381-12M01	18 - 20
61N-45510-10	20 - 36	701-48213-00	25 - 19	689-81826-10	12 - 15	6E9-85516-70	8 - 9	90119-08015	2 - 25	90386-08032	14 - 19
61N-45536-00	20 - 5	701-48221-00	25 - 6	689-81830-11	12 - 4	663-85518-00	15 - 10	90149-05M05	26 - 8	90386-10009	15 - 16
61N-45551-00	20 - 38	701-48222-00	25 - 27	689-81831-00	12 - 5	61N-85537-00	8 - 13	90149-05M13	14 - 14	90386-12069	13 - 11
61N-45560-00	20 - 42	701-48229-00	25 - 26			61N-85540-13	9 - 13	90149-14030	17 - 5	90386-22M67	17 - 11
6L2-45567-00-10	20 - 41										

NUMERICAL INDEX
INDEX NUMERIQUE

PART NO. NO. PIECES	REF. NO.	PART NO. NO. PIECES	REF. NO.	PART NO. NO. PIECES	REF. NO.	PART NO. NO. PIECES	REF. NO.	PART NO. NO. PIECES	REF. NO.	PART NO. NO. PIECES	REF. NO.
90386-38022	18-13	91490-12010	15-37	92995-06600	7-27	93210-45161	28-8	97013-06016	2-15	97880-06016	19-8
90386-38090	18-11	91490-16010	7-47		9-4		28-25	97013-06025	4-6	97890-05006	5-22
90386-47M22	18-10		15-23		9-15	93210-46M16	3-8	97013-06035	4-8	97980-04110	5-6
90387-06M26	4-16		15-34		9-22	93210-58M21	2-9	97013-06050	4-10	97980-04112	5-14
90387-06M59	15-3		17-40		9-28		27-4	97013-08012	12-18	98503-04006	11-26
90387-06M60	15-24	91490-20010	15-46		14-9	93210-64ME7	20-54	97013-08030	12-16	98503-05028	6-23
90387-06013	7-44	91490-30022	21-16		14-11		28-14	97075-06020	20-58	98580-05010	25-32
90387-06504	10-3	91490-30025	19-15		16-3	93210-65M50	20-57	97075-08025	18-41	98580-05020	25-42
90387-08M03	17-23	91690-30008	17-20		16-6		28-16	97075-08030	19-4	98586-05016	23-4
90387-08M25	13-3	91690-30012	16-13		16-9	93306-00612	20-53	97090-06012	9-11	98980-04006	5-17
90387-10M39	18-15		16-19		18-19	93306-305U3	3-9		9-16	99080-05600	17-36
90387-13003	14-3	91690-30016	17-15		18-32	93310-62406	3-14		9-23	99530-10014	7-25
90387-32002	3-16	91690-40016	15-42		20-17	93315-220V7	20-6		11-9		
90387-33001	14-4	91690-40018	15-17		20-23	93315-22004	20-55	97095-06010	7-40		
90430-08020	20-30	91690-40035	17-46		20-59	93332-000W5	20-3		9-3		
	20-35	91690-40048	4-23		28-28	93332-00005	20-40	97095-06012	15-6		
	28-13	92780-06025	25-20	92995-08600	13-7	93390-00009	3-17		16-2		
90445-09M75	6-5	92903-05600	7-46		17-24	93399-99951	3-6	97095-06016	7-20		
90445-10M41	2-35	92903-06600	2-16		18-42	93430-06024	25-35		16-5		
90445-11M05	23-11		4-7		18-49	93440-62057	3-11		16-8		
90445-11M06	23-9		4-9		19-5	93602-20M02	3-21	97095-06018	18-18		
90446-10M02	11-31		4-11		19-11	93604-10M03	20-25	97095-06020	6-3		
90464-08M07	10-6	92903-08600	12-17	92995-10600	21-5	93606-11M24	21-3		9-14		
90465-06M88	4-24		12-19	93101-16001	2-8	93606-12019	2-5		9-21		
90465-13M11	9-19	92903-10600	14-17		27-3		18-17		9-27		
90465-18147	11-29	92990-05100	6-24	93101-20M07	20-56		19-3		14-10		
90467-08004	6-6		26-10		28-15	93608-12063	18-8		14-22		
	6-15	92990-05600	8-20	93101-22067	20-28	93700-06M03	17-16		18-31		
	6-32		11-8		28-12		17-27	97095-06022	2-10		
90480-10155	11-25		15-37	93102-25008	2-7		18-22	97095-06025	20-22		
90480-14M14	1-9		15-45		27-2	94702-00160	2-42	97095-06035	7-23		
90480-15M06	13-2		26-11	93102-32M07	3-7	94702-00217	2-42		7-26		
90480-17M08	11-1	92990-06100	9-12	93210-03261	11-28	94702-00271	2-42	97095-06040	6-29		
	13-21		9-17	93210-06ME6	20-21	95303-08700	7-12		20-16		
90480-17165	11-17		9-24		28-9	95380-03600	6-20		28-27		
90480-25161	9-26		11-10	93210-08287	23-14	95380-05600	15-13	97095-06045	15-4		
90480-29045	18-5	92990-06300	20-33		23-16		26-9	97095-06050	14-8		
90501-09M08	15-29		25-25	93210-22164	20-8	95380-05700	15-8	97095-08020	19-10		
90501-10065	20-48	92990-08600	16-15		28-17	95380-06600	7-28	97095-08065	18-48		
90501-10071	16-20		16-21	93210-26130	20-9		15-48	97313-08030	7-10		
90501-10227	7-38	92990-10200	18-28		28-6		25-44	97390-06018	25-22		
90501-10264	16-14		18-37	93210-32738	6-10	95380-08600	6-11	97607-04112	8-11		
90501-14M07	15-28	92990-14200	21-14		27-16		17-25	97607-06125	8-12		
90501-23215	14-18	92995-06600	2-11	93210-37160	18-12		18-46	97802-04006	8-8		
90502-10M07	17-21		6-4	93210-40659	4-14	95380-08700	13-6	97880-05012	8-19		
90506-16M17	17-45		6-30		27-12		13-8		11-27		
90506-30M27	17-41		7-21		27-27	95895-06035	20-32	97880-05025	11-7		
90508-14M13	15-40		7-24	93210-45161	20-14	97013-06014	6-13	97880-06010	8-22		

25B/30H
PARTS CATALOGUE
©2001 by Yamaha Motor Co., Ltd.
1st Edition, Dec. 2001
All rights reserved.
Any reprinting or unauthorized use
without the written permission of
Yamaha Motor Co., Ltd.
is expressly prohibited.

25B/30H
CATALOGUE DE PIECES DETACHEES
©2001 Yamaha Motor Co., Ltd.
1ère Edition, Dec. 2001
Tous droits réservés.
Toute réimpression ou utilisation
sans la permission écrite de la
Yamaha Motor Co., Ltd.
est formellement interdite.