

**PARTS  
CATALOGUE  
CATALOGUE  
DE PIÉCES DÉTACHÉES**

**F9.9HMH'10** (6CA2)

---



1J6CA-300F1

( )

F9.9HMH  
PARTS CATALOGUE  
©2009 by Yamaha Motor Co., Ltd.  
1st edition, June 2009  
All rights reserved.  
Any reprinting or unauthorized use  
without the written permission of  
Yamaha Motor Co., Ltd.  
is expressly prohibited.  
Printed in Japan.

F9.9HMH  
CATALOGUE DE PIECES DETACHEES  
©2009 par Yamaha Motor Co., Ltd.  
1<sup>re</sup> édition, juin 2009  
Tous droits réservés  
Toute réimpression ou utilisation  
non autorisée sans la permission écrite  
de la Yamaha Motor Co., Ltd.  
est formellement interdite.  
Imprimé au Japon

# FOREWORD

This Parts Catalogue is related to the parts for the model(s) on the cover page. When you are ordering replacement parts, please refer to this Parts Catalogue and quote both part numbers and part names correctly.

1. Modifications or additions which have been made after the issue of the Parts Catalogue will be announced in the Parts News.  
It is advisable that you make the necessary corrections to the Parts Catalogue according to the Parts News.

2. Abbreviations

The following abbreviations are used in this Parts Catalogue.

“UR” Use specified parts number.

“UN” Use as many as needed.

“AP” Alternate Parts

“LM” Locally Made (Parts need to be ordered locally)

“F#” Frame No. (Applicable machine No.)

“O/S” Over Size

3. The number of components for assembly

- Parts, which are to be supplied in an assembly, are listed with a dot (.) in front of the part name as shown below.
- The numeral appearing to the right of each component part indicates the quantity of parts for each assembly unit.

PART NO.	DESCRIPTION	Q'TY	REMARKS
2F5-83310-60	FRONT FLASHER LIGHT ASSY	2	
115-83311-60	.BULB (6V-18W)	1	

4. Applicable colours of graphics are represented in the “REMARKS” as shown below.

PART NO.	DESCRIPTION	Q'TY	REMARKS
2N4-24110-00-X5	FUEL TANK COMP.	2	MXR
3J1-24240-10	.GRAPHIC, FUEL TANK	1	FOR MXR

5. Note that the illustrations for reference in finding parts numbers are not to be used for assembling. When assembling, please use the applicable service manual.

6. The asterisk (\*) before a reference number indicates modified items after the first edition.

7. Applicable Serial No.

Engine Serial No.

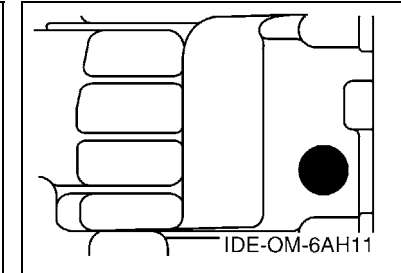
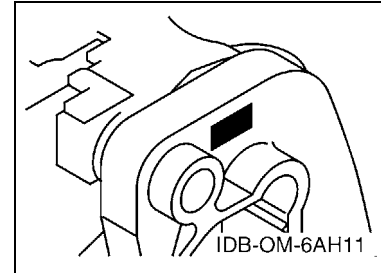

8. Applicable Engine Starting Serial No.

Model	Serial No.	Model	Serial No.
F9.9H	6CAK-1000685		

9. Applicable Colour Code

Abbreviation	Colour Name	Colour Code
DBNM2	DARK BLUISH GRAY METALLIC 2	004D

10. Quantity Column Information

Column No.	Name Of Q'ty Column	Applicable Model
1	6CA2	F9.9HMH

# AVANT-PROPOS

Ce catalogue de pièces détachées concerne les pièces pour le(s) modèle(s) indiqué(s) sur la page de couverture. Lorsque vous commandez des pièces de rechange, veuillez vous référer à ce catalogue de pièces détachées et indiquer clairement les numéros et les noms des pièces détachées.

1. Les modifications ou ajouts ayant été effectués après la parution du catalogue de pièces détachées seront décrits dans les Bulletins d'information concernant les pièces détachées.

Il est recommandé que vous apportiez les corrections nécessaires au catalogue des pièces détachées en vous référant aux Bulletins d'information.

2. Abréviations

Dans ce catalogue, les abréviations suivantes sont utilisées:

“UR” Utiliser le numéro de pièces spécifié.

“UN” Utiliser autant que nécessaire.

“AP” Pièces de substitution

“LM” Fabrication locale (les pièces doivent être commandées localement.)

“F#” N° de cadre (applicable au N° de série)

“O/S” Surdimensionné

3. Nombre de pièces d'un assemblage

- Les pièces fournies comme composants d'un assemblage sont précédées d'un point (.) de la manière indiquée ci-dessous.
- Le chiffre apparaissant à la droite de chaque composant indique la quantité de pièces pour chaque unité d'assemblage.

N° PIECES	DESCRIPTION	QTE	REMARQUES
2F5-83310-60	ENS. CLIGNOTANT AVANT	2	
115-83311-60	.AMPOULE (6V-18W)	1	

4. Les couleurs concernant les graphiques sont indiquées dans la colonne “REMARQUES”, comme indiqué ci-dessous.

N° PIECES	DESCRIPTION	QTE	REMARQUES
2N4-24110-00-X5	RESERVOIR A ESSENCE.	2	MXR
3J1-24240-10	.GRAPHIQUE	1	POUR MXR

5. Veuillez noter que les illustrations sont indiquées à titre de référence pour trouver les numéros de pièces, non pour être utilisées lors de l'assemblage. Lors de l'assemblage, veuillez utiliser le manuel d'entretien adéquat.

6. L'astérisque (\*) placé devant un numéro de référence indique des éléments qui ont été modifiés après la première édition.

7. N° de série applicable

N° de Série du moteur

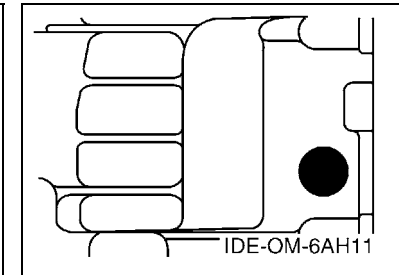
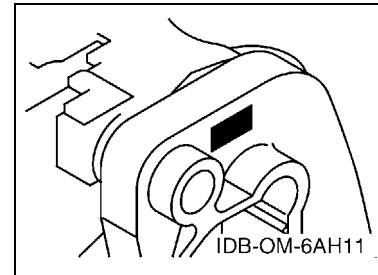

8. N° de série initial du moteur applicable

Modèle	N° de série	Modèle	N° de série
F9.9H	6CAK-1000685		

9. Code couleur applicable

Abréviation	Nom de la couleur	Code couleur
DBNM2	DARK BLUISH GRAY METALLIC 2	004D

10. Informations relatives à la colonne Quantité

N° de la colonne	Nom de la colonne Qté	Modèle applicable
1	6CA2	F9.9HMH

# CONTENTS

TOP COWLING .....	1
CYLINDER & CRANKCASE 1 .....	2
CRANKSHAFT & PISTON .....	4
CYLINDER & CRANKCASE 2 .....	5
VALVE .....	6
INTAKE .....	7
CARBURETOR .....	8
OIL PUMP .....	10
FUEL .....	11
STARTER .....	13
GENERATOR .....	15
ELECTRICAL 1 .....	16
ELECTRICAL 2 .....	18
ELECTRICAL 3 .....	19
BOTTOM COWLING .....	20
STEERING .....	22
STEERING FRICTION .....	24
CONTROL .....	25
BRACKET 1 .....	27
BRACKET 2 .....	29
UPPER CASING .....	30
OIL PAN .....	31
LOWER CASING & DRIVE 1 .....	32
LOWER CASING & DRIVE 2 .....	35
FUEL TANK .....	37
REPAIR KIT 1 .....	38
REPAIR KIT 2 .....	39
REPAIR KIT 3 .....	40

## INDEX

NUMERICAL INDEX .....	42
-----------------------	----

# TABLE DES MATIERES

CAPOT SUPERIEUR .....	1
CYLINDRE & CARTER 1 .....	2
VILEBREQUIN & PISTON .....	4
CYLINDRE & CARTER 2 .....	5
SOUPAPE .....	6
ADMISSION .....	7
CARBURATEUR .....	8
POMPE A HUILE .....	10
CARBURANT .....	11
DEMARREUR .....	13
GENERATRICE .....	15
PARTIE ELECTRIQUE 1 .....	16
PARTIE ELECTRIQUE 2 .....	18
PARTIE ELECTRIQUE 3 .....	19
CAPOT INFERIEUR .....	20
DIRECTION .....	22
CUVETTE POIGNEE DE DIRECTION .....	24
COMMANDE .....	25
SUPPORT 1 .....	27
SUPPORT 2 .....	29
FOURREAU .....	30
VENTILATEUR D'HUILE .....	31
BOITIER D'HELICE TRANSMISSION1 .....	32
BOITIER D'HELICE TRANSMISSION2 .....	35
RESERVOIR A CARBURANT .....	37
KITS DE REPARATION 1 .....	38
KITS DE REPARATION 2 .....	39
KITS DE REPARATION 3 .....	40

## INDEX

INDEX NUMERIQUE .....	42
-----------------------	----

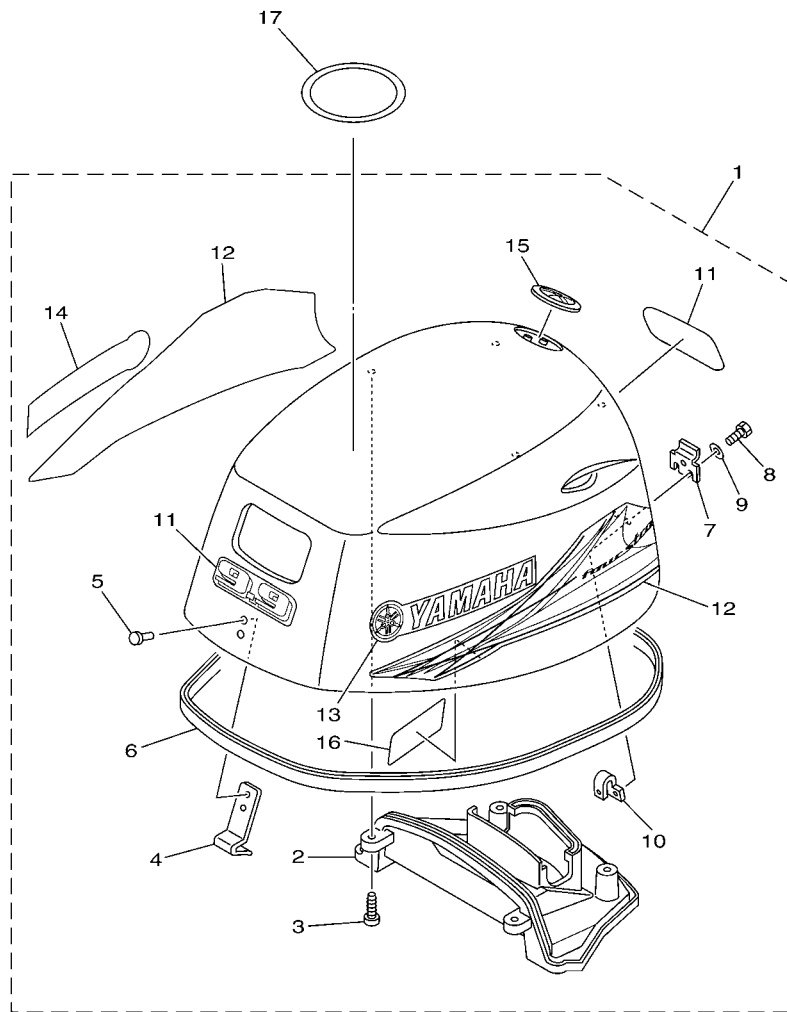

  
6CA1300-H010

FIG. 1 TOP COWLING

CAPOT SUPERIEUR

REF. NO.	PART NO. N° PIECES	DESCRIPTION DESCRIPTION	6CA2				REMARKS REMARQUES
1	6CA-42610-00-4D	TOP COWLING ASSY CAPOT (ENS.)	1				
2	6AH-42613-00	.MOLDING, AIR DUCT .MANCHON A AIR	1				
3	97780-50616	.SCREW, TAPPING .VIS, TETE BOMBEE	4				
4	6AH-42651-00	.HOOK .CROCHET	1				
5	90266-06M02	.RIVET .RIVET	2				
6	6AH-42615-00	.SEAL .JOINT	1				
7	60R-42652-00	.HOOK .CROCHET	1				
8	97095-05014	.BOLT .BOULON	2				
9	92995-05600	.WASHER .RONDELLE	2				
10	6AH-42649-00	.HOLDER, CLAMP BAND .SUPPORT, SANDOW DE SERRAGE	1				
11	6CA-42677-00	.GRAPHIC, FRONT .ADHESIF, AVANT	2				
12	6CA-W0070-00	.GRAPHIC SET .JEU DIEMBLEMES	1				
13	6CA-42681-00	.MARK, COWLING .ADHESIF, CAPOT	1				
14	6CA-42682-00	.MARK, COWLING .ADHESIF, CAPOT	1				
15	6AH-42697-01	.TUNING FORK MARK .MARQUE, YAMAHA	1				
16	6AH-42735-00	.PROTECTOR .PROTECTEUR	1				
17	67F-13434-10	LABEL, CAUTION ETIQUETTE, ATTENTION	1				

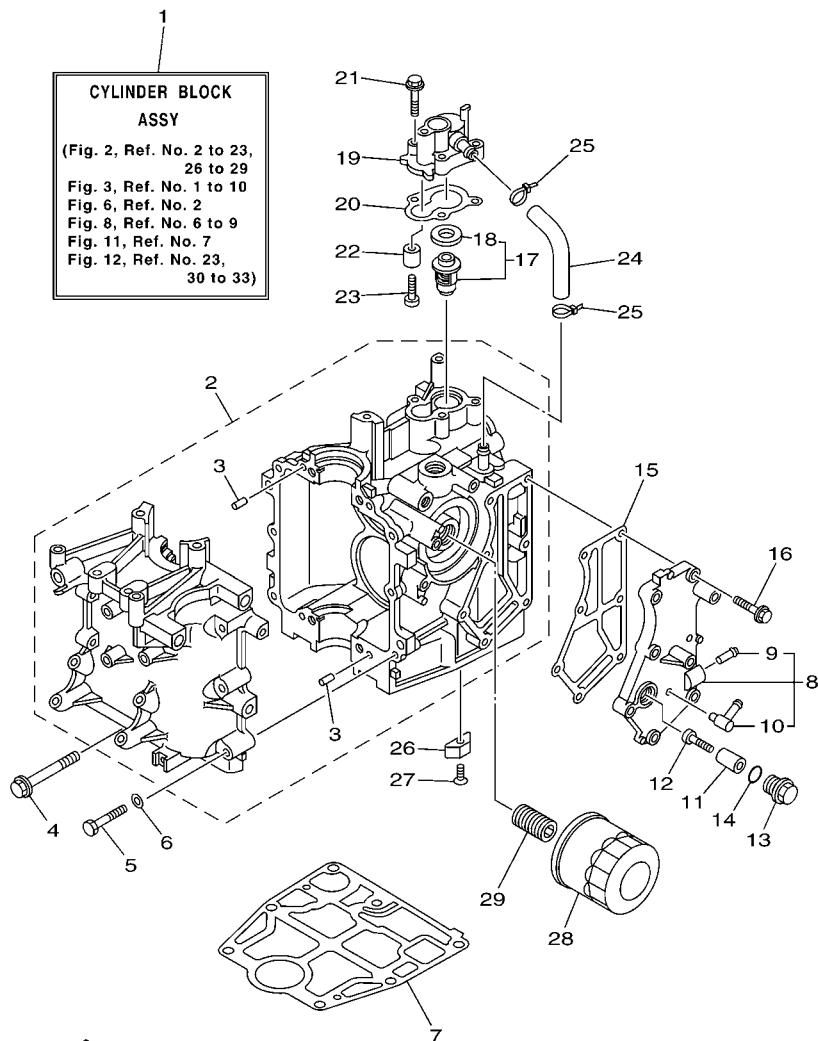

**CYLINDER BLOCK  
ASSY**  
(Fig. 2, Ref. No. 2 to 23,  
26 to 29  
Fig. 3, Ref. No. 1 to 10  
Fig. 6, Ref. No. 2  
Fig. 8, Ref. No. 6 to 9  
Fig. 11, Ref. No. 7  
Fig. 12, Ref. No. 23,  
30 to 33)

**FIG. 2 CYLINDER & CRANKCASE 1      CYLINDRE & CARTER 1**

REF. NO.	PART NO. N° PIECES	DESCRIPTION DESCRIPTION	6CA2				REMARKS REMARQUES
1	6AH-W009B-00-1S	CYLINDER BLOCK ASSY CYLINDRE GROUPE (ENS.)	1				
2	6AH-15100-00-1S	CRANKCASE ASSY CARTER DE MOTEUR COMPLET	1				
3	93606-12019	.PIN, DOWEL .GOUILLE	4				
4	90119-08093	BOLT, WITH WASHER BOULON, AVEC RONDELLE	4				
5	97013-06040	BOLT BOULON	6				
6	92903-06600	WASHER, PLATE RONDELLE, PLATE	6				
7	6AH-11351-00	GASKET, CYLINDER JOINT, D'EMBASE	1				
8	6AH-41113-00-1S	OUTER COVER, EXHAUST COUVERCLE, ECHAPPEMENT	1				
9	650-24378-00	.PIPE, JOINT 4 .DURITE RACCORDEMENT 3	1				
10	676-11372-00	.NIPPLE, HOSE .RACCORD, TUYAU	1				
11	6G8-11325-00	ANODE ANODE	1				
12	97880-05025	SCREW, PAN HEAD VIS, TETE TRONCONIQUE	1				
13	6G8-11197-01	PLUG, BLIND PLOT, BORGNE	1				
14	93210-13M63	O-RING JOINT TORIQUE	1				
15	6AH-41114-00	GASKET, EXHAUST OUTER COVER JOINT, COUVERCLE D'ECHAPPEMENT	1				
16	90119-06MA3	BOLT, WITH WASHER BOULON, AVEC RONDELLE	7				
17	6AH-12411-00	THERMOSTAT THERMOSTAT	1				
18	688-12412-00	.SEAL, THERMOSTAT JOINT, THERMOSTAT	1				
19	6AH-12413-00-1S	COVER, THERMOSTAT COUVERCLE, THERMOSTAT	1				
20	6AH-12414-00	GASKET, COVER JOINT, COUVERCLE	1				
21	90119-06MA3	BOLT, WITH WASHER BOULON, AVEC RONDELLE	3				
22	6G8-11325-00	ANODE ANODE	1				
23	97880-05025	SCREW, PAN HEAD VIS, TETE TRONCONIQUE	1				
24	6AH-12481-00	PIPE 1 DURITE 1	1				
25	90465-11M10	CLAMP BRIDE	2				
26	6E5-11325-00	ANODE ANODE	1				
27	98780-04016	SCREW, FLAT HEAD VIS A TETE FRAISEE	1				

6AH1300-F020



FIG. 3 CRANKSHAFT & PISTON

VILEBREQUIN & PISTON

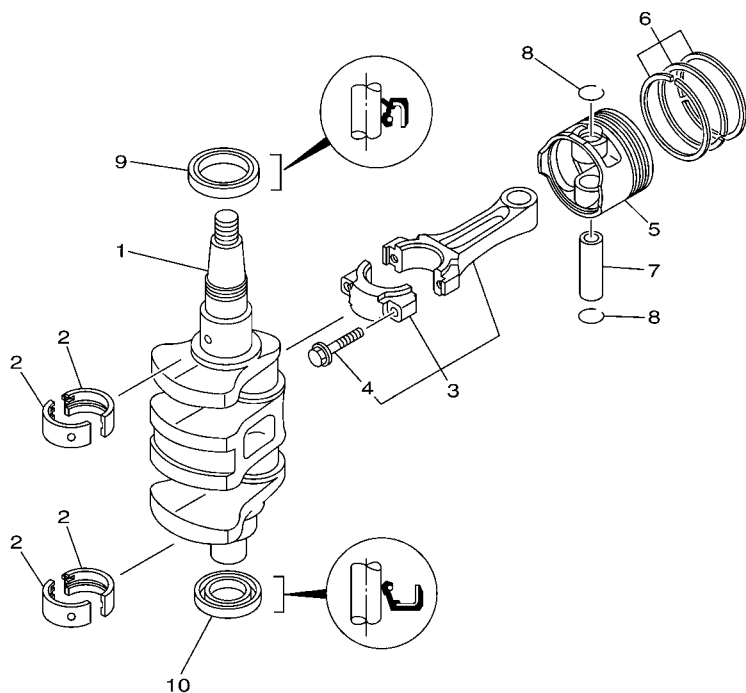

  
6AH1100-F030

REF. NO.	PART NO. N° PIECES	DESCRIPTION DESCRIPTION	6CA2				REMARKS REMARQUES
1	6AH-11411-00	CRANKSHAFT VILEBREQUIN COMPLET	1				
2	6AH-11416-00	PLANE BEARING, CRANKSHAFT 1 COUSSINET DE VILEBREQUIN 1	4				UR BLUE UR BLUE
	6AH-11416-10	PLANE BEARING, CRANKSHAFT 1 COUSSINET DE VILEBREQUIN 1	4				UR BLACK UR BLACK
	6AH-11416-20	PLANE BEARING, CRANKSHAFT 1 COUSSINET DE VILEBREQUIN 1	4				UR BROWN UR BROWN
3	6AH-11650-00	CONNECTING ROD ASSY BIELLE COMPLETE	2				
4	6AH-11654-00	.BOLT, CONNECTING ROD .BOULON, BIELLE	2				
5	6AH-11631-00	PISTON (STD) PISTON (STD)	2				
	6AH-11635-00	PISTON (0.25MM O/S) PISTON (0.25MM O/S)	2				AP AP
	6AH-11636-00	PISTON (0.50MM O/S) PISTON (0.50MM O/S)	2				AP AP
6	6AH-11603-00	PISTON RING SET (STD) JEU DE SEGMENTS (STD)	2				
	6AH-11604-00	PISTON RING SET (0.25MM O/S) JEU DE SEGMENTS (0.25MM O/S)	2				AP AP
	6AH-11605-00	PISTON RING SET (0.50MM O/S) JEU DE SEGMENTS (0.50MM O/S)	2				AP AP
7	137-11633-10	PIN, PISTON AXE, PISTON	2				
8	93450-17129	CIRCLIP CIRCLIP, TYPE S	4				
9	93102-37004	OIL SEAL JOINT SPY	1				
10	93102-25014	OIL SEAL JOINT SPY	1				

**FIG. 4 CYLINDER & CRANKCASE 2      CYLINDRE & CARTER 2**

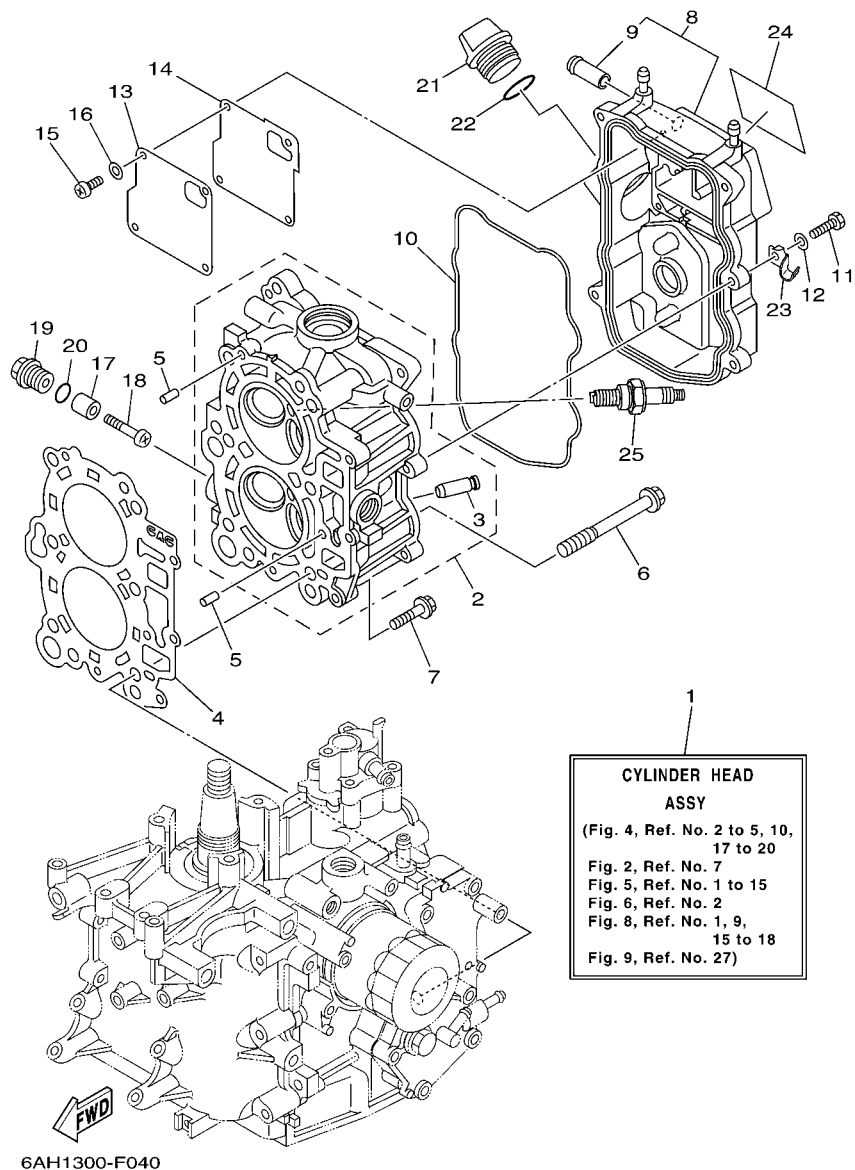

**CYLINDER HEAD  
ASSY**  
(Fig. 4, Ref. No. 2 to 5, 10,  
17 to 20  
Fig. 2, Ref. No. 7  
Fig. 5, Ref. No. 1 to 15  
Fig. 6, Ref. No. 2  
Fig. 8, Ref. No. 1, 9,  
15 to 18  
Fig. 9, Ref. No. 27)

6AH1300-F040

REF. NO.	PART NO. N° PIECES	DESCRIPTION DESCRIPTION	6CA2				REMARKS REMARQUES
1	6AG-W009A-00-1S	CYLINDER HEAD ASSY CULASSE (ENS.)	1				
2	6AH-11111-00-94	HEAD, CYLINDER 1 CULASSE	1				
3	6AH-11133-10	.GUIDE, VALVE 1 .GUIDE, SOUPAPE 1	4				
4	6AG-11181-00	GASKET, CYLINDER HEAD 1 JOINT, DE CULASSE 1	1				
5	93606-12019	PIN, DOWEL GOUPILLE	2				
6	90105-09006	BOLT, FLANGE BOULON	6				
7	90119-06MA3	BOLT, WITH WASHER BOULON, AVEC RONDELLE	3				
8	6AH-11191-00-1S	COVER, CYLINDER HEAD 1 COUVERCLE, CULASSE 1	1				
9	6AH-11372-00	.NIPPLE, HOSE .RACCORD, TUYAU	1				
10	6AH-11356-00	SEAL, CYLINDER 2 JOINT, SPY CYLINDRE	1				
11	97095-06020	BOLT BOULON	5				
12	92995-06600	WASHER RONDELLE	5				
13	6AH-11168-00	COVER, BREATHER COUVERCLE, RENIFLARD	1				
14	6AH-11169-00	GASKET, BREATHER COVER JOINT, COUVERCLE DE RENIFLARD	1				
15	98507-04010	SCREW, PAN HEAD VIS, TETE TRONCONIQUE	4				
16	92907-04600	WASHER RONDELLE	4				
17	6G8-11325-00	ANODE ANODE	2				
18	97880-05025	SCREW, PAN HEAD VIS, TETE TRONCONIQUE	2				
19	6G8-11197-01	PLUG, BLIND PLOT, BORGNE	2				
20	93210-13M63	O-RING JOINT TORIQUE	2				
21	6G8-15363-00	PLUG, OIL PLOT, HUILE	1				
22	93210-24M79	O-RING JOINT TORIQUE	1				
23	90465-08059	CLAMP BRIDE	1				
24	62Y-12138-60	MARK, CAUTION MAKER	1				
25	94702-00418	PLUG, SPARK (NGK DPR6EB) BOUGIE D,ALLUMAGE (NGK DPR6EB)	2				

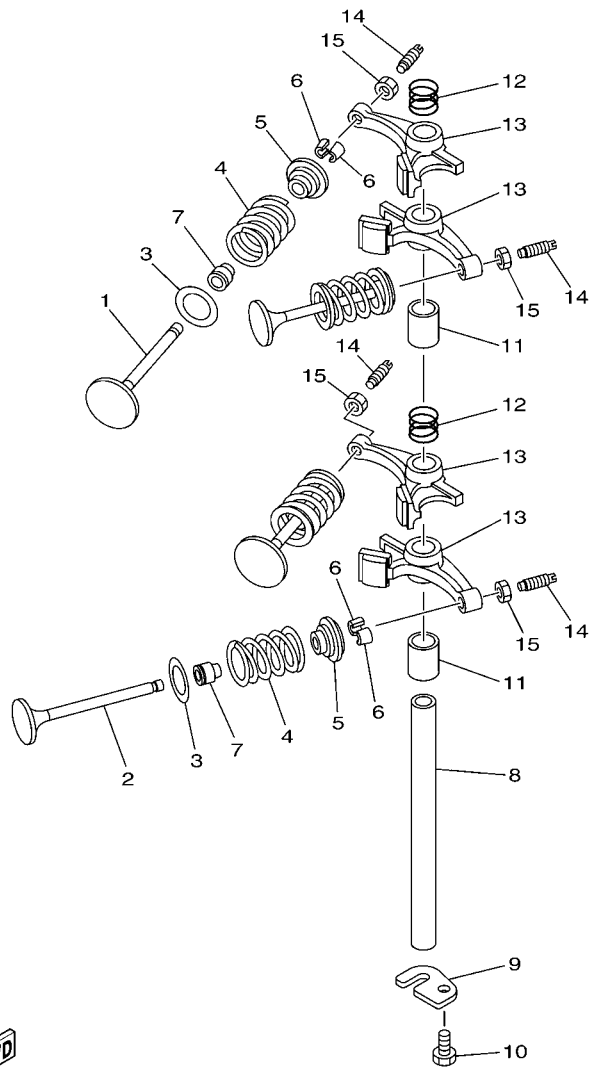

6AH1100-F050

FIG. 5 VALVE

SOUPAPE

REF. NO.	PART NO. N° PIECES	DESCRIPTION DESCRIPTION	6CA2				REMARKS REMARQUES
1	6AH-12111-00	VALVE, INTAKE SOUPAPE, ADMISSION	2				
2	6AH-12121-00	VALVE, EXHAUST SOUPAPE, ECHAPPEMENT	2				
3	62Y-12116-00	SEAT, VALVE SPRING SIEGE, RESSORT DE SOUPAPE	4				
4	3YF-12113-00	SPRING, VALVE INNER RESSORT DE SOUPAPE, INTERNE	4				
5	30X-12117-00	RETAINER, VALVE SPRING BUTEE DE RESSORT DE SOUPAPE	4				
6	30X-12118-00	COTTER, VALVE FRAISE, SOUPAPE	8				
7	51Y-12119-00	SEAL, VALVE STEM JOINT, QUEUE DE SOUPAPE	4				
8	66M-12146-00	SHAFT, ROCKER AXE, CULBUTEUR	1				
9	6AH-12279-00	PLATE PLAQUE	1				
10	97013-06012	BOLT BOULON	1				
11	90387-13006	COLLAR COLLERETTE	2				
12	90501-120A5	SPRING, COMPRESSION RESSORT, COMPRESSION	2				
13	6AH-12151-00	ARM, VALVE ROCKER CULBUTEUR	4				
14	64J-12159-00	SCREW, VALVE ADJUSTING VIS, REGLAGE DE SOUPAPE	4				
15	62Y-12158-00	NUT, LOCK CONTRE-ECROU	4				



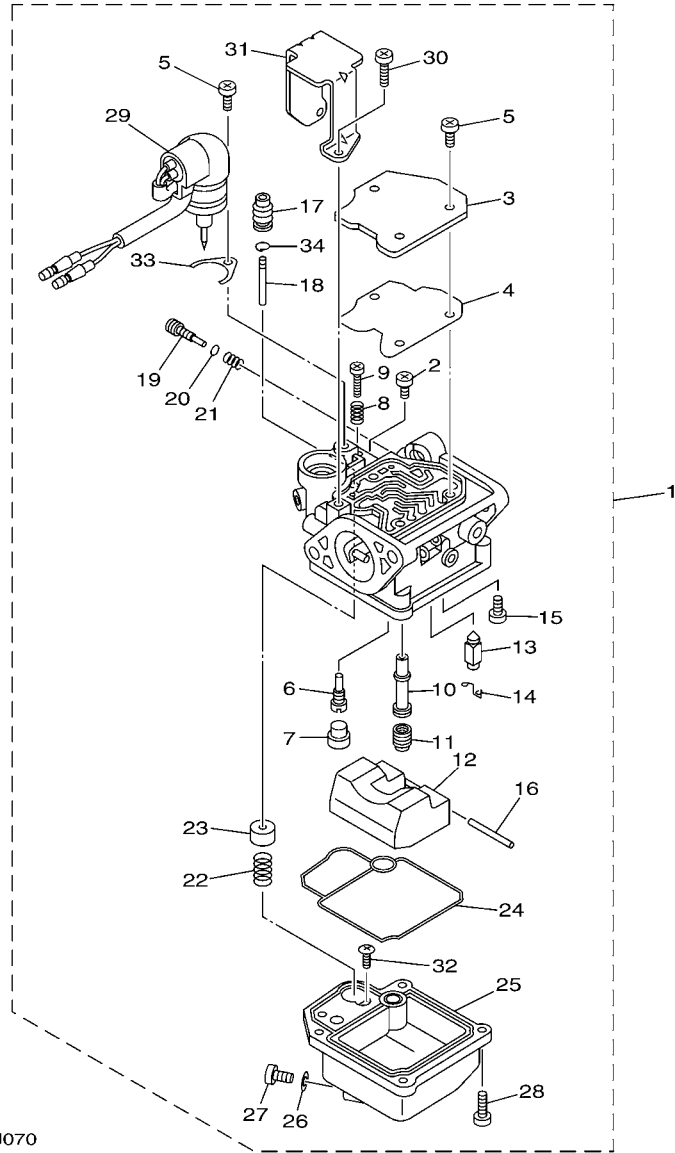

6BY2280-J070

FIG. 7 CARBURETOR

CARBURATEUR

REF. NO.	PART NO. N° PIECES	DESCRIPTION DESCRIPTION	6CA2				REMARKS REMARQUES
1	6AG-14301-11	CARBURETOR ASSY 1 CARBURATEUR COMPLET 1	1				
2	98580-04006	.SCREW, PAN HEAD .VIS	1				
3	65W-14572-00	.PLATE .PLAQUE	1				
4	65W-14126-10	.GASKET .JOINT	1				
5	97980-04110	.SCREW, WITH WASHER .VIS, AVEC RONDELLE	4				
6	6AG-14948-02	.JET (#38) .GICLEUR (#38)	1				
7	679-14966-00	.RUBBER CAP .CAOUTCHOUC CASQUILLO	1				
8	90501-10326	.SPRING, COMPRESSION .RESSORT, COMPRESSION	1				
9	63V-14523-00	.SCREW, STOP .VIS, BUTEE	1				
10	6AH-14947-20	.JET, NEEDLE .GICLEUR DE STARTER	1				
11	676-14943-19	.JET, MAIN (#80) .GICLEUR, PRINCIPAL (#80)	1				
12	6AH-14985-00	.FLOAT .FLOTTEUR	1				
13	6AH-14546-00	.VALVE, NEEDLE .POINTEAU	1				
14	663-14159-00	.CLIP .JONC	1				
15	98580-04008	.SCREW, PAN HEAD .VIS	1				
16	6H4-14548-00	.PIN, FLOAT ARM .AXE, BRAS DE FLOTTEUR	1				
17	65W-14373-02	.COVER, PLUNGER CAP .COUVERCLE DE PLONGEUR	1				
18	6AH-14379-00	.ROD, STARTER .TRINGLE, STARTER	1				
19	67C-14923-20	.SCREW, PILOT .VIS, RALENTI	1				
20	67C-14397-00	.O-RING .JOINT TORIQUE	1				
21	67C-14555-00	.SPRING .RESSORT	1				
22	65W-14335-00	.SPRING, PLUNGER .RESSORT, PLONGEUR	1				
23	6AH-14371-00	.PLUNGER, STARTER .PLONGEUR, STARTER	1				
24	6AH-14384-00	.GASKET, FLOAT CHAMBER .JOINT, CUVE DE FLOTTEUR	1				
25	6AH-14980-00	.BODY, FLOAT CHAMBER .CORPS, CUVE DE FLOTTEUR	1				
26	65W-14398-00	.GASKET .JOINT	1				
27	65W-14992-00	.SCREW, DRAIN .BOUCHON, PURGE	1				



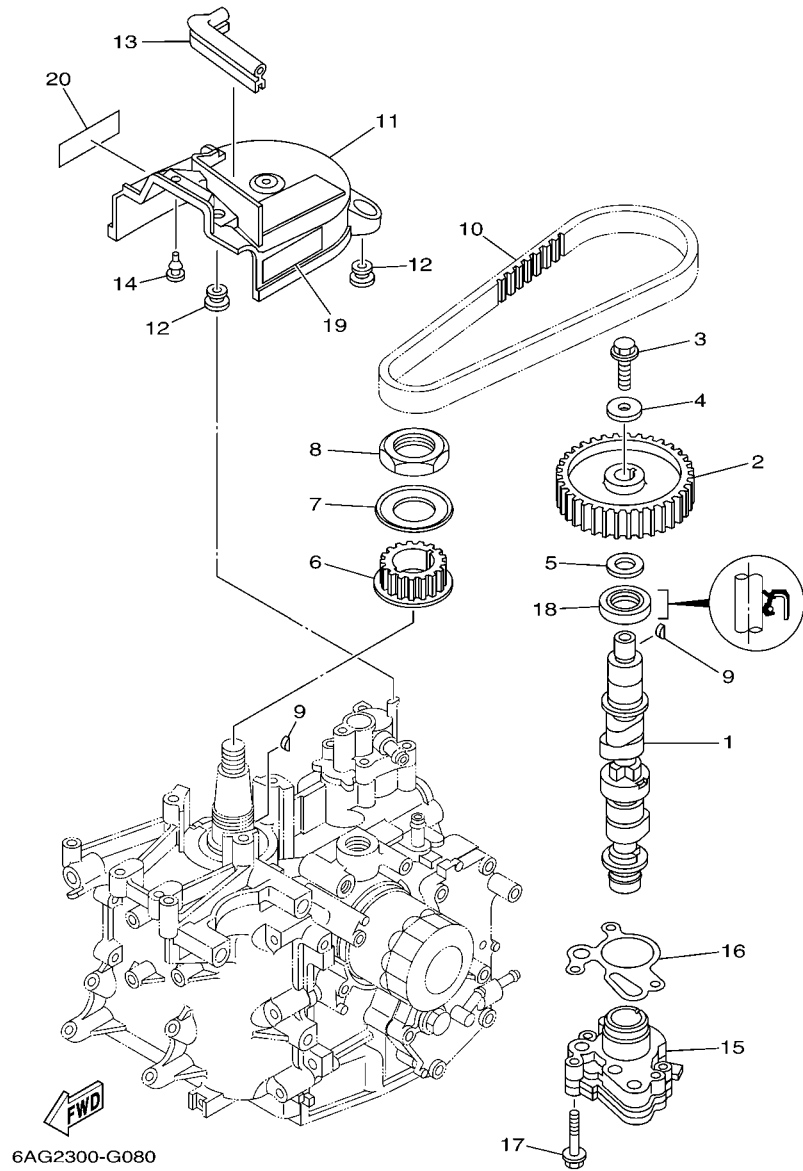

6AG2300-G080

FIG. 8 OIL PUMP

POMPE A HUILE

REF. NO.	PART NO. N° PIECES	DESCRIPTION DESCRIPTION	6CA2				REMARKS REMARQUES
1	6AG-12170-00	CAMSHAFT ASSY 1 ENS ARBRE A CAMES 1	1				
2	6AH-11537-00-94	GEAR, DRIVEN PIGNON SECONDAIRE	1				
3	90105-081A7	BOLT, FLANGE BOULON	1				
4	90201-08784	WASHER, PLATE RONDELLE, PLATE	1				
5	90201-15423	WASHER, PLATE RONDELLE, PLATE	1				
6	6AH-11536-00	GEAR, DRIVE ENGRENAGE, MENANT	1				
7	6AH-11557-00	WASHER 1 RONDELLE 1	1				
8	90170-30003	NUT ECROU	1				
9	90280-03M01	KEY, WOODRUFF CLAVETTE, DEMI-LUNE	2				
10	6AH-46241-00	V-BELT COURROIE TRAPEZOIDALE	1				
11	6AH-46297-00	COVER, DUST COUVERCLE, POUSSIERE	1				
12	90480-10627	GROMMET PASSE-FIL	3				
13	6AH-42617-00	DAMPER, FORM BOURRELET, CAOUTCHOUC	1				
14	90480-06M19	GROMMET PASSE-FIL	1				
15	6AH-13300-00	OIL PUMP ASSY POMPE A HUILE COMPLETE	1				
16	6AH-13329-00	GASKET, PUMP COVER JOINT, COUVERCLE DE POMPE	1				
17	90105-06035	BOLT, FLANGE BOULON	3				
18	93102-22009	OIL SEAL JOINT SPY	1				
19	6AH-81994-40	LABEL, SAFETY ETIQUETTE, SECURITE	1				
20	6AH-81994-50	LABEL, SAFETY ETIQUETTE, SECURITE	1				

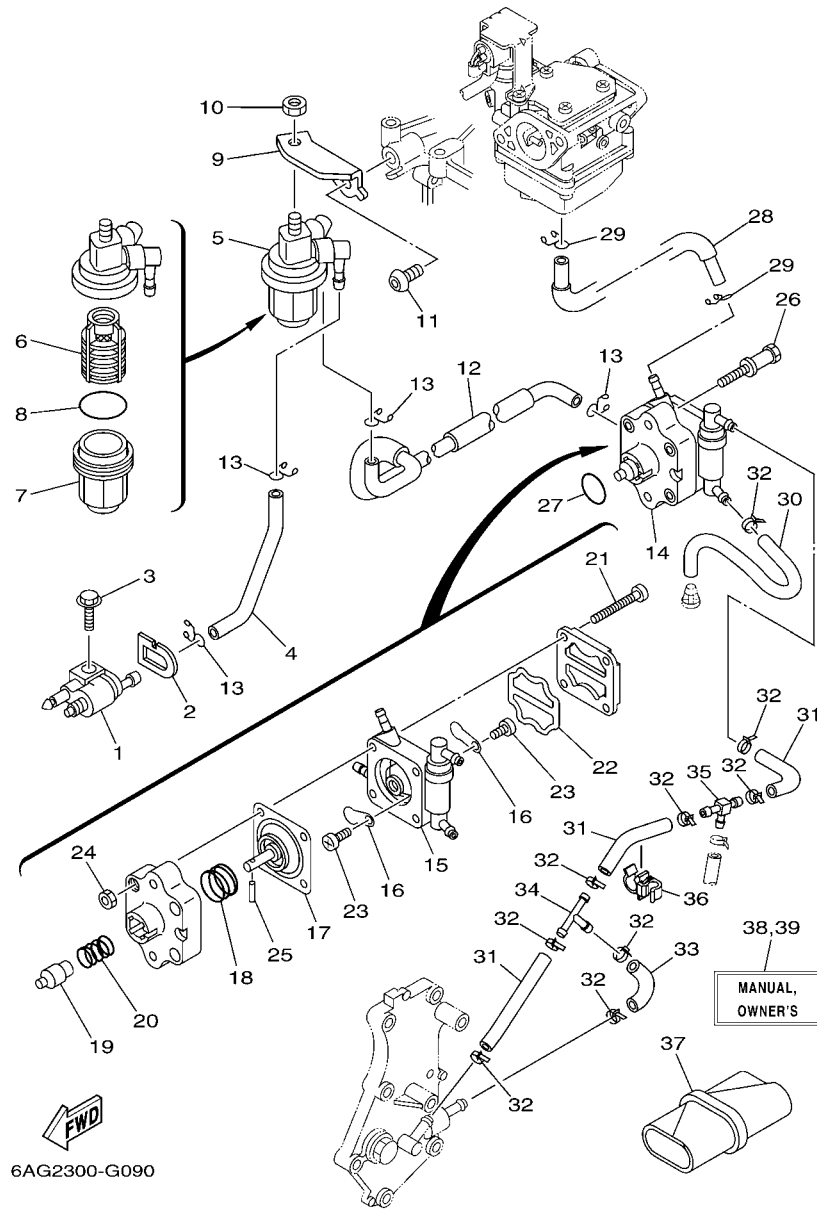

6AG2300-G090

FIG. 9 FUEL

CARBURANT

REF. NO.	PART NO. N° PIECES	DESCRIPTION DESCRIPTION	6CA2				REMARKS REMARQUES
1	6G1-24304-02	FUEL PIPE JOINT COMP. 1 DURITE RACCORDEMT. A ESSENCE	1				
2	61N-24329-00	SEAL JOINT	1				
3	95895-06020	BOLT, FLANGE BOULON	1				
4	6AH-24311-00	PIPE, FUEL 1 DURITE A ESSENCE	1				
5	61N-24560-00	FILTER ASSY ENS FILTRE	1				
6	61N-24563-00	.ELEMENT, FILTER .ELEMENT, FILTRE	1				
7	61N-24521-00	.CUP, FILTER .CUVETTE, FILTRE	1				
8	93210-32738	.O-RING .JOINT TORIQUE	1				
9	6AH-24566-00	BRACKET, FILTER SUPPORT, FILTRE	1				
10	95380-08600	NUT ECROU	1				
11	90111-08055	BOLT, HEX. SOCKET BUTTON BOULON	1				
12	6AH-24312-00	PIPE 2 DURITE 2	1				
13	90467-09M17	CLIP JONC	4				
14	6AH-24410-00	FUEL PUMP ASSY POMPE A ESSENCE	1				
15	6AH-24413-00	.BODY 2 .CORPS 2	1				
16	6A0-24421-01	.VALVE, CHECK .SOUPAPE, RETENUE	2				
17	66M-24411-11	.DIAPHRAGM .DIAPHRAGME	1				
18	66M-24423-00	.SPRING, DIAPHRAGM .RESSORT, DIAPHRAGME	1				
19	66M-13131-10	.PLUNGER .PLONGEUR	1				
20	66M-24454-00	.SPRING .RESSORT	1				
21	66M-24444-00	.SCREW .VIS	4				
22	66M-24471-01	.DIAPHRAGM .DIAPHRAGME	1				
23	6E7-14325-00	.SCREW, PAN HEAD .VIS TETE CONIQUE	2				
24	95380-04600	.NUT .ECROU	4				
25	66M-24374-00	.PIN .GOUILLE	1				
26	90109-06215	BOLT BOULON	2				
27	93210-20M65	O-RING JOINT TORIQUE	1				

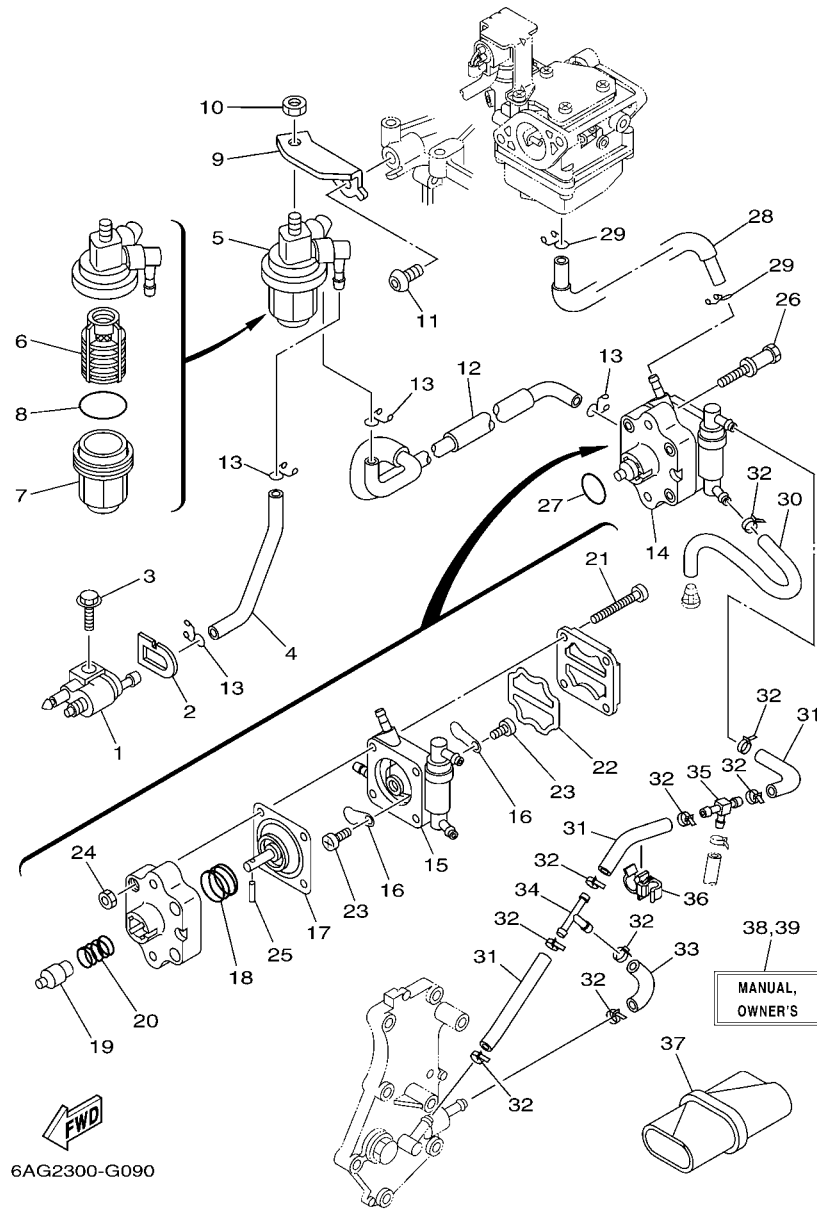

FIG. 9 FUEL

CARBURANT

REF. NO.	PART NO. N° PIECES	DESCRIPTION DESCRIPTION	6CA2				REMARKS REMARQUES
28	6AH-24313-00	PIPE 3 DURITE 3	1				
29	90467-09M17	CLIP JONC	2				
30	6AH-24315-00	PIPE 5 DURITE 5	1				
31	90445-09026	HOSE DURITE	3				
32	90465-11M10	CLAMP BRIDE	9				
33	6AH-24317-00	PIPE 7 DURITE 7	1				
34	688-24378-00	PIPE, JOINT 3 DURITE RACCORDEMENT 3	1				
35	6C5-24378-00	PIPE, JOINT 3 DURITE RACCORDEMENT 3	1				
36	90464-09018	CLAMP BRIDE	1				
37	62Y-28100-00	TOOL KIT TROUSSE A OUTILS	1				
38	6AG-28199-74-E0	MANUAL, OWNER'S MANUEL D'UTILISATION	1				UR (E) UR (E)
	6AG-28199-74-F0	MANUAL, OWNER'S MANUEL D'UTILISATION	1				UR (F) UR (F)
	6AG-28199-74-S0	MANUAL, OWNER'S MANUEL D'UTILISATION	1				UR (ES) UR (ES)
	6AG-28199-74-G0	MANUAL, OWNER'S MANUEL D'UTILISATION	1				UR (D) UR (D)
	6AG-28199-74-D0	MANUAL, OWNER'S MANUEL D'UTILISATION	1				UR (NL) UR (NL)
	6AG-28199-74-H0	MANUAL, OWNER'S MANUEL D'UTILISATION	1				UR (I) UR (I)
39	6AG-28199-84-K0	MANUAL, OWNER'S MANUEL D'UTILISATION	1				UR (DK) UR (DK)
	6AG-28199-84-R0	MANUAL, OWNER'S MANUEL D'UTILISATION	1				UR (GR) UR (GR)
	6AG-28199-84-P0	MANUAL, OWNER'S MANUEL D'UTILISATION	1				UR (P) UR (P)
	6AG-28199-84-N0	MANUAL, OWNER'S MANUEL D'UTILISATION	1				UR (N) UR (N)
	6AG-28199-84-M0	MANUAL, OWNER'S MANUEL D'UTILISATION	1				UR (S) UR (S)
	6AG-28199-84-L0	MANUAL, OWNER'S MANUEL D'UTILISATION	1				UR (SF) UR (SF)

FIG. 10 STARTER

DEMARREUR

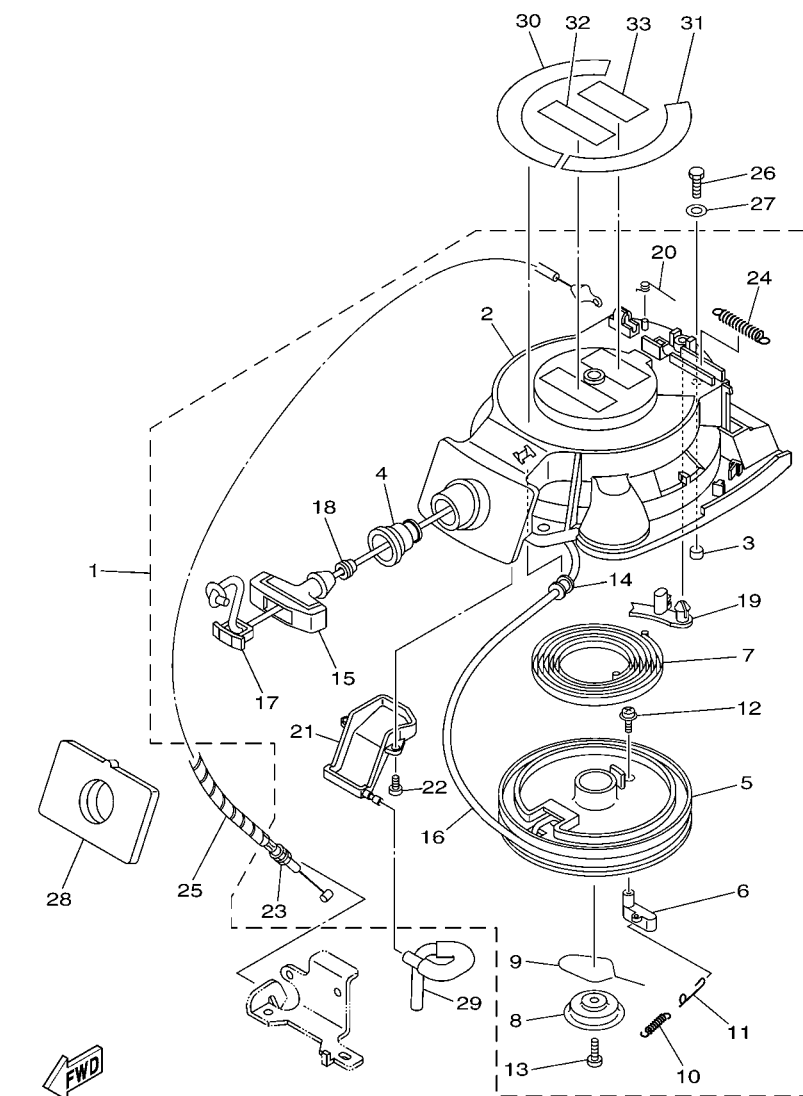

6CA2300-J100

\*1: CUT FROM 50M ROLLS, PART NO. 90890-44373, CUTTING LENGTH 1.8M

\*1: A PRELEVER SUR BOBINE 50M, REFERENCE 90890-44373, LONGUEUR DE COUPE 1.8M

REF. NO.	PART NO. N° PIECES	DESCRIPTION DESCRIPTION	6CA2				REMARKS REMARQUES
1	6AH-15710-01	STARTER ASSY DEMARREUR COMPLET	1				
2	6AH-15711-00	.CASE, STARTER .CARTER DE DEMARREUR	1				
3	67D-15764-00	.COLLAR 1 .COLLERETTE 1	3				
4	6AH-15795-00	.GUIDE, ROPE .GUIDE DE CABLE	1				
5	63V-15714-00	.DRUM, SHEAVE .TAMBOUR, POULIE	1				
6	6AH-15741-10	.PAWL, DRIVE .CLIQUET, ENTRAINEMENT	1				
7	63V-15713-00	.SPRING, STARTER .RESSORT DE DEMARREUR	1				
8	68T-15716-00	.PLATE, DRIVE .PLAQUE, ENTRAINEMENT	1				
9	63V-15705-01	.SPRING, DRIVE PAWL .RESSORT DE CLIQUET	1				
10	63V-15767-01	.SPRING .RESSORT	1				
11	68T-15784-00	.SPRING, RETURN .RESSORT, RAPPEL	1				
12	63V-15793-00	.SCREW .VIS	1				
13	68T-15793-00	.SCREW .VIS	1				
14	68T-15764-00	.COLLAR 1 .COLLERETTE 1	1				
15	689-15755-01	.HANDLE, STARTER .POIGNEE, DE DEMARREUR	1				
16	*	.WIRE, STARTER (L:1800MM) .CABLE DE DEMARREUR (L:1800MM)	1				*1 *1
17	6F5-15779-02	.COVER .COUVERCLE	1				
18	6A0-15789-00	.DAMPER .AMORTISSEUR	1				
19	66T-15794-00	.STOPPER .BUTEE	1				
20	66T-15734-00	.SPRING, RETURN .RESSORT, RAPPEL	1				
21	6AH-15782-00	.COVER, SHEAVE .COUVERCLE, POULIE	1				
22	6AH-15793-00	.SCREW .VIS	2				
23	6AH-15770-00	.CABLE COMP., STARTER STOP .CABLE, BUTEE DE DEMAR	1				
24	66T-15731-00	.SPRING, RETURN .RESSORT, RAPPEL	1				
25	90446-06M90	HOSE (L120) DURITE (L120)	1				
26	97095-06020	BOLT BOULON	3				
27	92995-06600	WASHER RONDELLE	3				



FIG. 11 GENERATOR

GENERATRICE

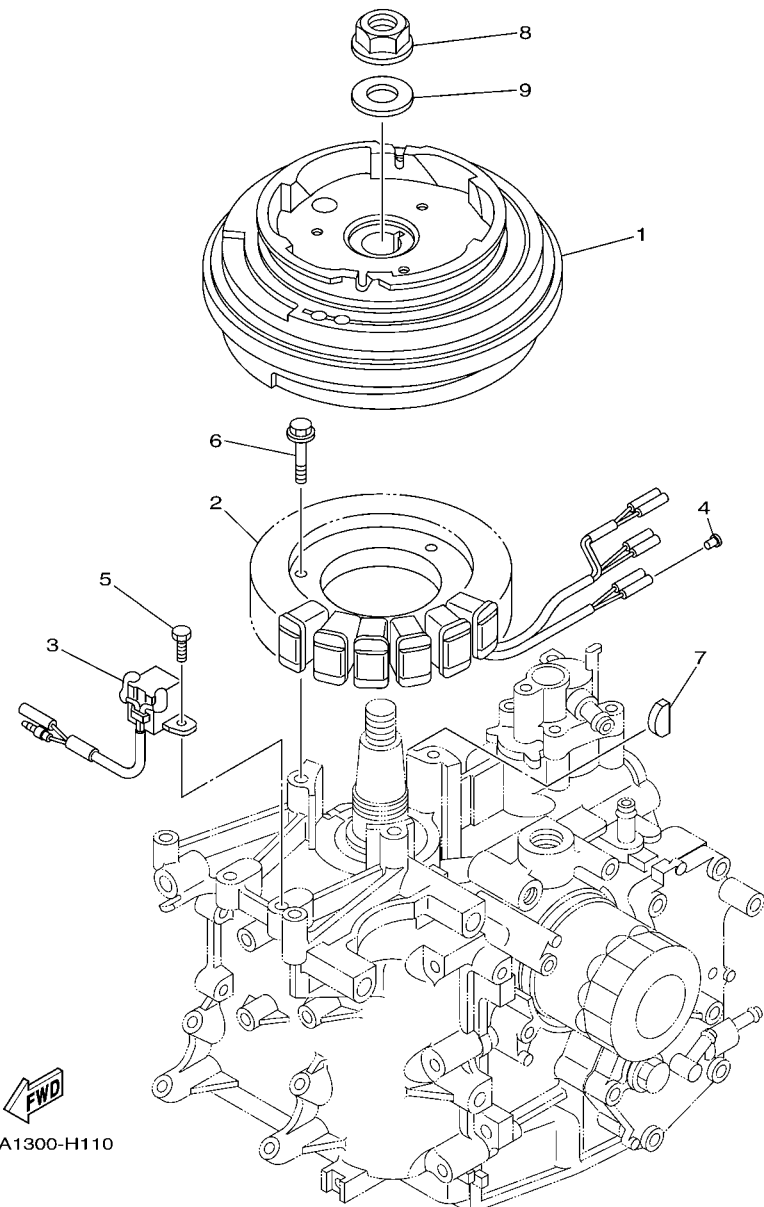

6CA1300-H110

REF. NO.	PART NO. N° PIECES	DESCRIPTION DESCRIPTION	6CA2				REMARKS REMARQUES
1	6AH-85550-00	ROTOR ASSY ROTOR CPLT	1				
2	6AH-85510-00	STATOR ASSY STATOR CPLT	1				
3	6AH-85580-00	COIL, PULSER BOBINE, PULSEUR	1				
4	703-82119-00	COVER, LEAD WIRE GARNITURE, FIL	2				
5	97095-05012	BOLT BOULON	2				
6	95895-06030	BOLT, FLANGE BOULON	3				
7	90280-05013	KEY, WOODRUFF CLAVETTE, DEMI-LUNE	1				
8	90179-16M05	NUT ECROU	1				
9	90201-16M44	WASHER, PLATE RONDELLE, PLATE	1				
-----							
-----							
-----							
-----							
-----							
-----							
-----							
-----							
-----							

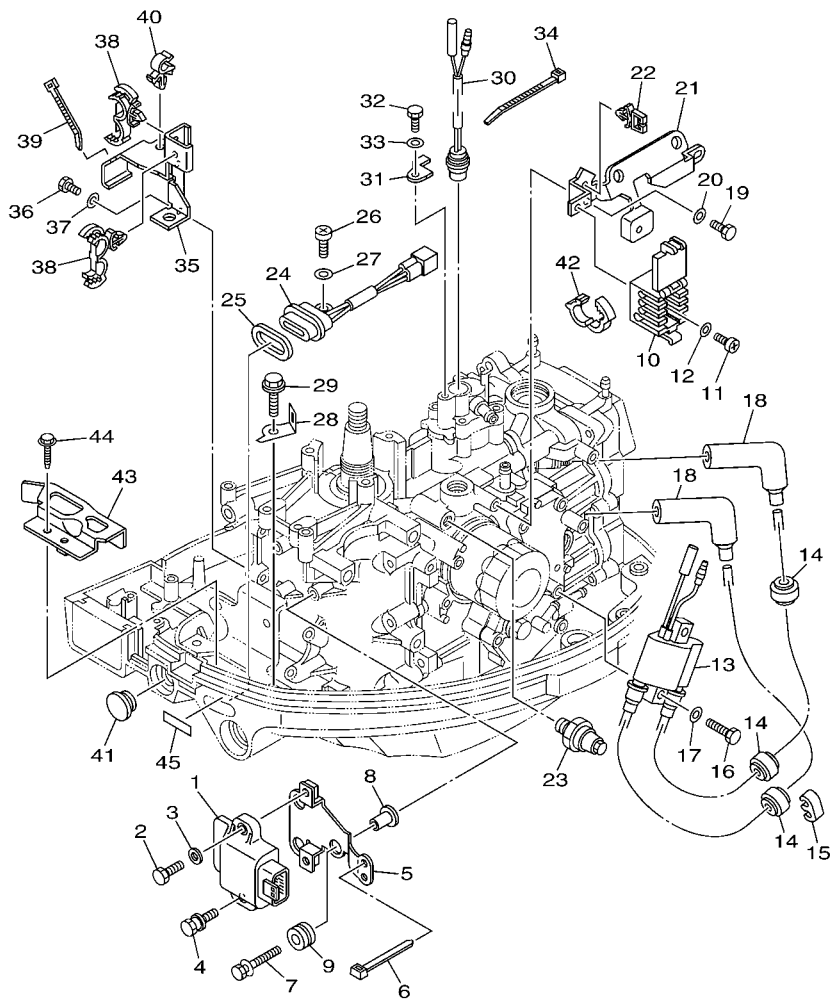

6CA1300-H120

FIG. 12 ELECTRICAL 1

PARTIE ELECTRIQUE 1

REF. NO.	PART NO. N° PIECES	DESCRIPTION DESCRIPTION	6CA2				REMARKS REMARQUES
1	6AH-85540-00	C.D.I. UNIT ASSY BLOC C.D.I.	1				
2	97095-06020	BOLT BOULON	1				
3	92995-06600	WASHER RONDELLE	1				
4	90109-06221	BOLT BOULON	1				
5	6AH-81948-00	BRACKET SUPPORT	1				
6	90465-13M18	CLAMP BRIDE	1				
7	90119-06M35	BOLT, WITH WASHER BOULON, AVEC RONDELLE	3				
8	90387-06M60	COLLAR COLLERETTE	3				
9	90480-10M23	GROMMET PASSE-FIL	3				
10	6AH-82522-00	CLAMP, COUPLER BRIDE, DE CONNECTEUR	1				
11	97880-06010	SCREW, PAN HEAD VIS, TETE TRONCONIQUE	1				
12	90201-06M05	WASHER, PLATE RONDELLE, PLATE	1				
13	6F5-85570-13	IGNITION COIL ASSY BOBINE D'ALLUMAGE (ENS.)	1				
14	90480-25003	GROMMET PASSE-FIL	3				
15	67F-82361-00	CLAMP, CORD COLLIER, CORDON	1				
16	97095-06025	BOLT BOULON	2				
17	92995-06600	WASHER RONDELLE	2				
18	6AH-82370-00	PLUG CAP ASSY ANTIPARASITE	2				
19	97095-06014	BOLT BOULON	2				
20	92995-06600	WASHER RONDELLE	2				
21	6AH-85542-00	BRACKET SUPPORT	1				
22	90464-07M56	CLAMP BRIDE	2				
23	64J-82504-00	OIL PRESSURE SWITCH ASSY CONTACTEUR DE PRESSION D'HUILE	1				
24	62Y-84301-00	PILOT LIGHT ASSY 1 LAMPE-TEMOIN 1	1				
25	6H4-83589-00	GASKET GARNITURE	1				
26	97885-06012	SCREW, PAN HEAD VIS, A ENCOCHE	1				
27	92995-06600	WASHER RONDELLE	1				

FIG. 12 ELECTRICAL 1

PARTIE ELECTRIQUE 1

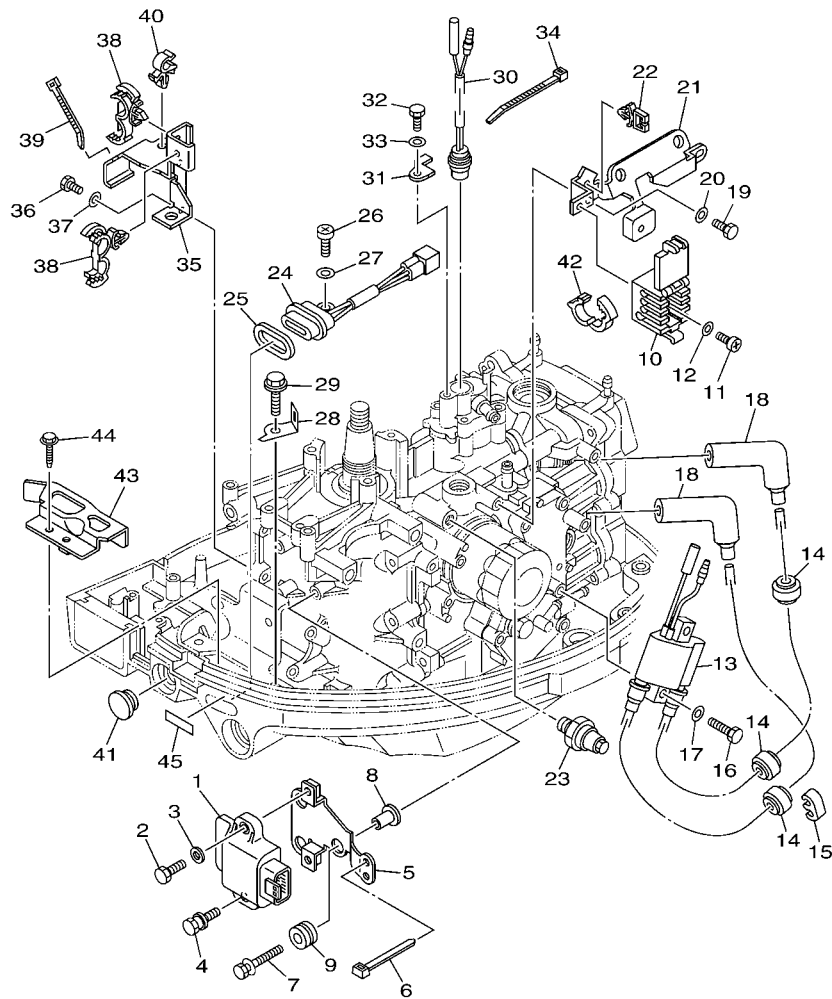

6CA1300-H120

REF. NO.	PART NO. N° PIECES	DESCRIPTION DESCRIPTION	6CA2				REMARKS REMARQUES
28	6AH-82388-00	PLATE PLAQUETTE	1				
29	90109-06M86	BOLT BOULON	1				
30	6AH-82560-00	THERMO SWITCH ASSY THERMO-CONTACT COMPLET	1				
31	6AH-82588-00	PLATE PLAQUE	1				
32	97095-06014	BOLT BOULON	1				
33	92995-06600	WASHER RONDELLE	1				
34	90465-11M10	CLAMP BRIDE	1				
35	6AH-82554-00	STAY, NEUTRAL SWITCH SUPPORT, CONT DE POINT-MORT	1				
36	97095-06016	BOLT BOULON	2				
37	92995-06600	WASHER RONDELLE	2				
38	90464-18246	CLAMP BRIDE	2				
39	90465-13M18	CLAMP BRIDE	1				
40	90464-10M32	CLAMP BRIDE	1				
41	6G1-42725-00	GROMMET PASSE-FIL	1				
42	90464-16003	CLAMP BRIDE	1				
43	6AH-82389-00	PLATE 2 PLAQUETTE 2	1				
44	90109-06M86	BOLT BOULON	1				
45	67C-85415-00	MARK, SIGNAL LAMP ETIQUETTE	1				

FIG. 13 ELECTRICAL 2

PARTIE ELECTRIQUE 2

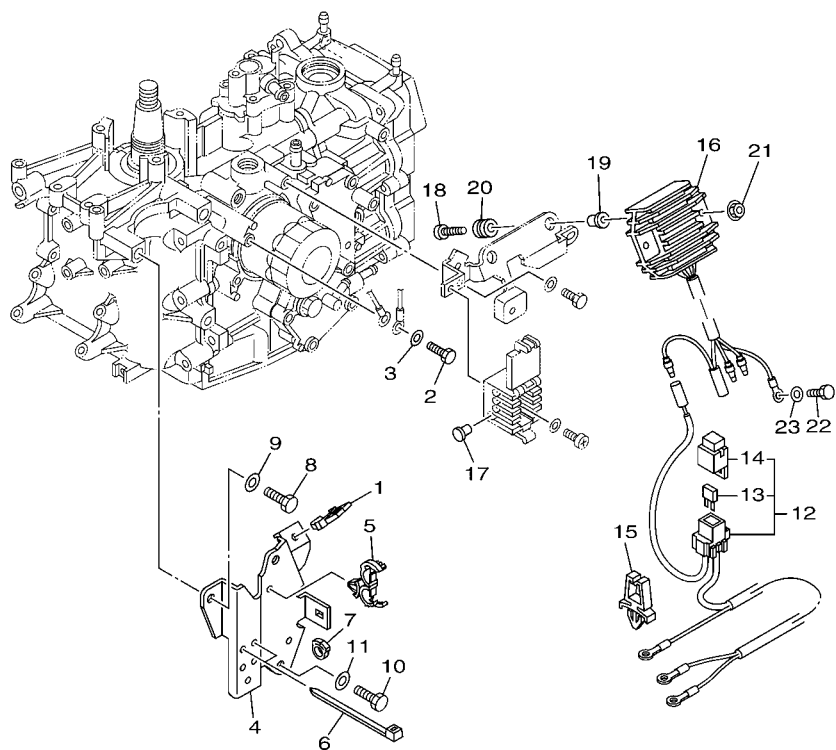

  
6CA1300-H130

REF. NO.	PART NO. N° PIECES	DESCRIPTION DESCRIPTION	6CA2				REMARKS REMARQUES
1	90464-08004	CLAMP BRIDE	1				
2	97095-06014	BOLT BOULON	1				
3	92995-06600	WASHER RONDELLE	1				
4	6AH-82398-00	PLATE 3 PLAQUETTE 3	1				
5	90464-18246	CLAMP BRIDE	1				
6	90465-13M18	CLAMP BRIDE	3				
7	90464-09010	CLAMP BRIDE	1				
8	97095-08025	BOLT BOULON	2				
9	92995-08600	WASHER RONDELLE	2				
10	97095-08016	BOLT BOULON	1				
11	92995-08600	WASHER RONDELLE	1				
12	6AH-81949-00	WIRE, LEAD FIL	1				AP AP
13	67F-82151-00	.FUSE (20A) .FUSIBLE (20A)	2				
14	67F-8215B-00	.CAP (BLACK) .BOUCHON (NOIR)	1				
15	90464-06001	CLAMP BRIDE	1				AP AP
16	6AH-81960-00	RECTIFIER & REGULATOR ASSY REDRESSEUR REGULATEUR CPLT	1				AP AP AP AP
17	703-82119-00	COVER, LEAD WIRE GARNITURE, FIL	1				AP AP AP
18	98980-06030	SCREW, BIND VIS, DE PRESSION	2				AP AP
19	90387-06M70	COLLAR COLLERETTE	2				AP AP
20	90480-13M24	GROMMET PASSE-FIL	2				AP AP
21	95780-06500	NUT, FLANGE ECROU	2				AP AP
22	97095-06014	BOLT BOULON	1				AP AP
23	92995-06600	WASHER RONDELLE	1				AP AP

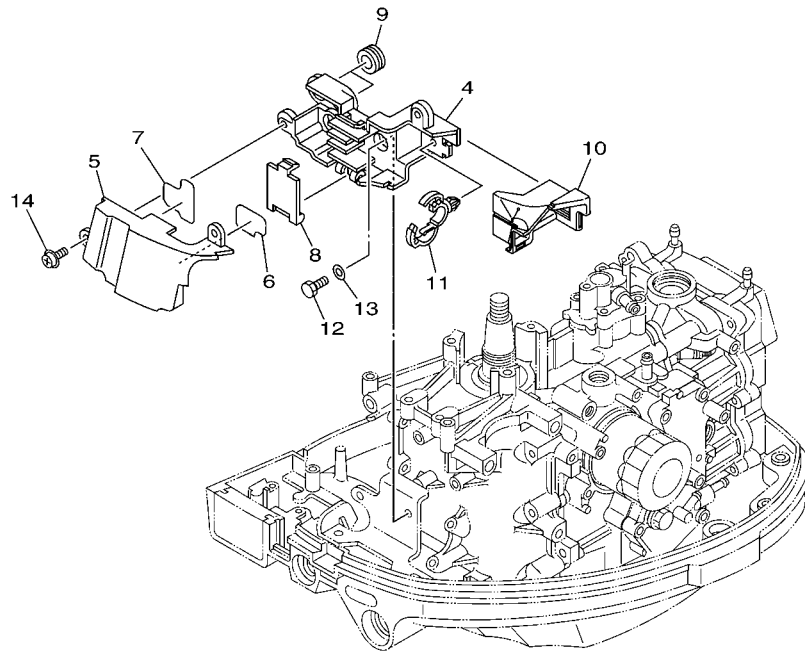
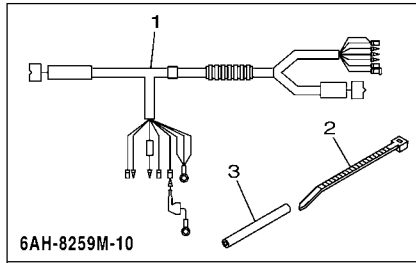

  
6CA1300-H140

FIG. 14 ELECTRICAL 3

PARTIE ELECTRIQUE 3

REF. NO.	PART NO. N° PIECES	DESCRIPTION DESCRIPTION	6CA2				REMARKS REMARQUES
1	6AH-8259M-10	WIRE HARNESS ASSY 2 FAISCEAU DE FILS	1				
2	90465-13M18	CLAMP BRIDE	1				
3	90445-08029	HOSE DURITE	1				
4	6AH-8552A-00	HOUSING CARTER	1				
5	6AH-8552E-00	COVER, CASE COUVERCLE	1				
6	6AH-42735-30	PROTECTOR PROTECTEUR	1				
7	6AH-42735-40	PROTECTOR PROTECTEUR	1				
8	6AH-85537-00	COVER COUVERCLE	1				
9	90480-19368	GROMMET PASSE-FIL	2				
10	6AH-85547-00	DAMPER AMORTISSEUR	1				
11	90464-20181	CLAMP BRIDE	1				
12	97095-06014	BOLT BOULON	2				
13	92995-06600	WASHER RONDELLE	2				
14	97985-06214	SCREW, WITH WASHER VIS, AVEC RONDELLE	2				

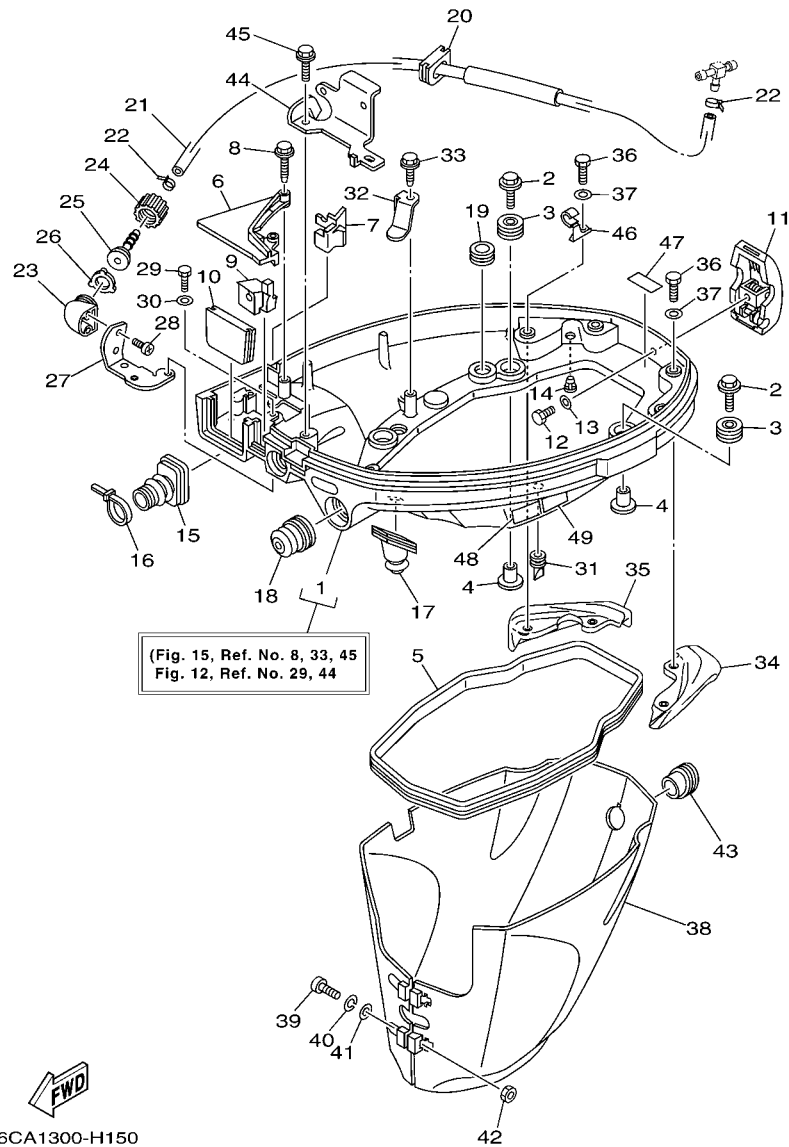

6CA1300-H150

FIG. 15 BOTTOM COWLING

CAPOT INFERIEUR

REF. NO.	PART NO. N° PIECES	DESCRIPTION DESCRIPTION	6CA2				REMARKS REMARQUES
1	6AH-42710-00-4D	BOTTOM COWLING ASSY ENS. EMBASE	1				
2	68F-85119-00	BOLT BOULON	4				
3	90480-21M82	GROMMET PASSE-FIL	4				
4	90387-06176	COLLAR COLLERETTE	4				
5	6AH-42716-00	RUBBER, SEAL 1 JOINT EN CAOUTCHOUC 1	1				
6	6AH-42738-00-4D	PLATE, FITTING ETRIER	1				
7	6AH-42718-00	RUBBER, SEAL 3 JOINT	1				
8	90109-06M82	BOLT BOULON	2				
9	6AH-42725-00	GROMMET PASSE-FIL	1				
10	6AH-42724-00	GROMMET PASSE-FIL	1				
11	6AH-42801-00	COWLING CLAMP COMP. BRIDE DE CAPOT COMP.	1				
12	97095-06012	BOLT BOULON	1				
13	92995-06600	WASHER RONDELLE	1				
14	6BL-44391-00	NIPPLE, HOSE RACCORD D'ESSENCE	1				
15	6AH-26326-00	GROMMET RONDELLE CAOUTCHOUC	1				
16	90465-11M10	CLAMP BRIDE	1				
17	6AH-42727-00	GROMMET PASSE-FIL	1				
18	65W-42726-00	GROMMET PASSE-FIL	1				
19	90480-16007	GROMMET PASSE-FIL	1				
20	6AH-42726-00	GROMMET PASSE-FIL	1				
21	6AH-24314-01	PIPE 4 DURITE 4	1				
22	90465-11M10	CLAMP BRIDE	2				
23	68T-12572-00	ADAPTER ADAPTATEUR	1				
24	6R3-12581-00	JOINT, HOSE 1 JOINT DE TUYAU	1				
25	6R3-12582-00	JOINT, HOSE 2 RACCORD DE TUYAU 1	1				
26	6R3-12583-00	GASKET, HOSE JOINT JOINT	1				
27	6AH-12535-00	PLATE PLAQUE	1				

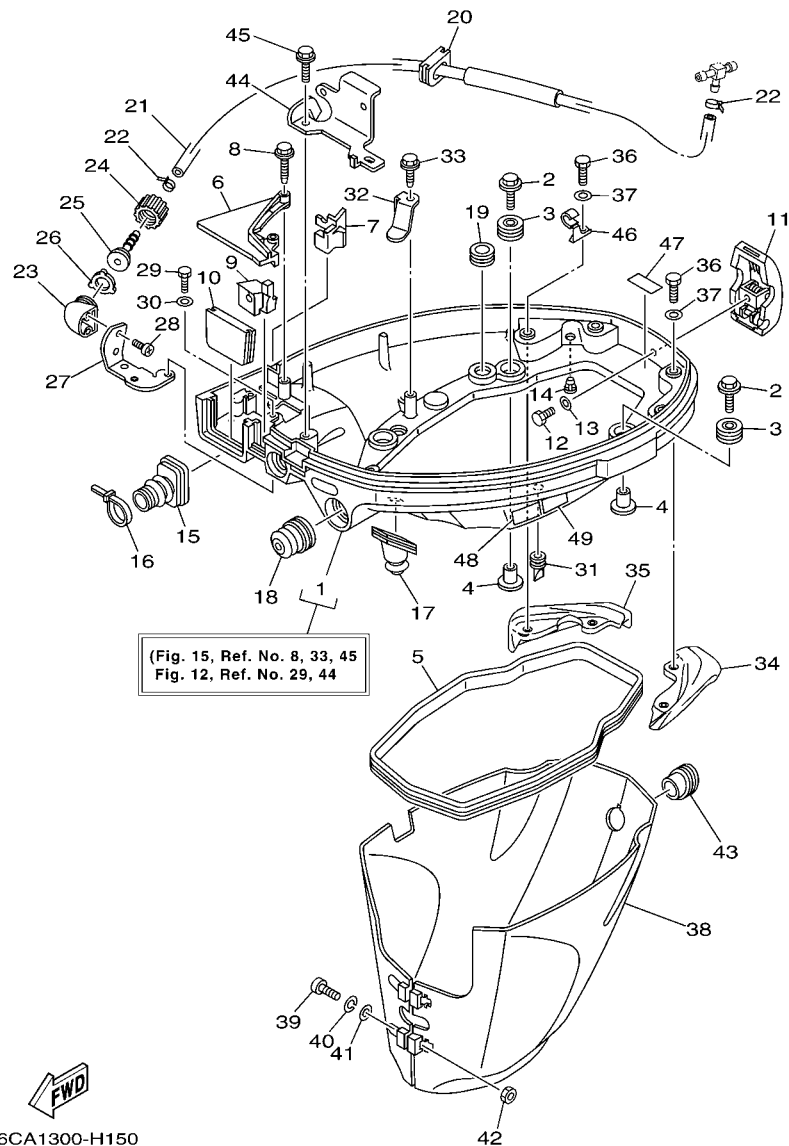

FIG. 15 BOTTOM COWLING

CAPOT INFERIEUR

REF. NO.	PART NO. N° PIECES	DESCRIPTION DESCRIPTION	6CA2				REMARKS REMARQUES
28	90167-06002	SCREW, TAPPING VIS, TETE FRAISEE	2				
29	97095-06010	BOLT BOULON	2				
30	92995-06600	WASHER RONDELLE	2				
31	65W-42717-00	RUBBER, SEAL 2 JOINT EN CAOUTCHOUC 2	2				
32	6AH-42743-00	BRACKET SUPPORT	1				
33	90109-06M86	BOLT BOULON	1				
34	6AH-42761-00	STOPPER PLAQUETTE	1				
35	6AH-42762-00	STOPPER PLAQUETTE	1				
36	97075-06012	BOLT BOULON	4				
37	92995-06600	WASHER RONDELLE	4				
38	6AH-42741-00	APRON CAPOT LATERAL	1				
39	97885-06030	SCREW, PAN HEAD VIS, A ENCOCHE	2				
40	92995-06100	WASHER, SPRING RONDELLE, GROWER	2				
41	92995-06600	WASHER RONDELLE	2				
42	95380-06600	NUT, HEXAGON ECROU	2				
43	6AH-42717-00	RUBBER, SEAL 2 JOINT EN CAOUTCHOUC 2	1				
44	6AH-15774-00	STAY 4 SUPPORT 4	1				
45	90109-06M86	BOLT BOULON	1				
46	90465-08M82	CLAMP BRIDE	1				
47	6C5-82377-00	LABEL ETIQUETTE	1				
48	6AH-42794-40	LABEL, WARNING (GENERAL) ETIQUETTE, AVERTISSEMENT	1				
49	6AH-42794-50	LABEL, WARNING (GENERAL) ETIQUETTE, AVERTISSEMENT	1				

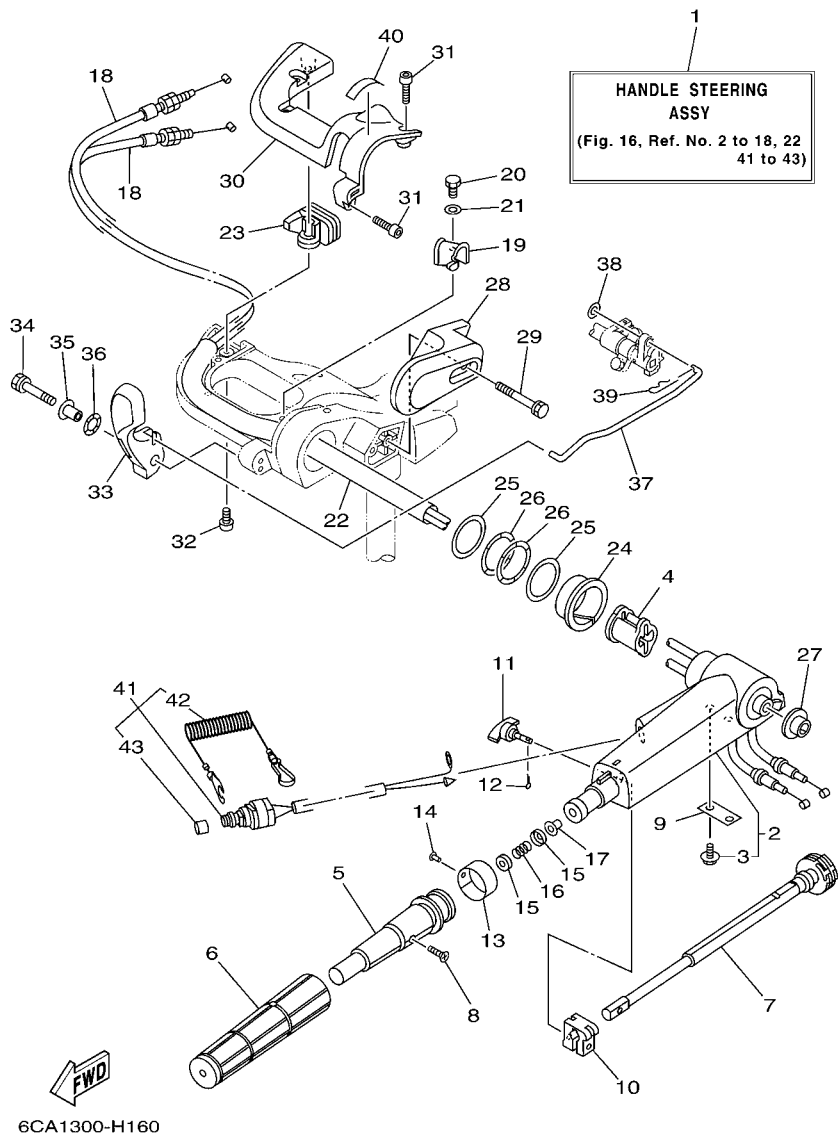

FIG. 16 STEERING

DIRECTION

REF. NO.	PART NO. N° PIECES	DESCRIPTION DESCRIPTION	6CA2				REMARKS REMARQUES
1	6AH-W0084-01-4D	HANDLE STEERING ASSY BARRE FRANCHE (ENS.)	1				
2	6AH-42101-01-4D	HANDLE, STEERING POIGNEE	1				
3	90109-06M86	.BOLT .BOULON	2				
4	6AH-26288-00	GROMMET, CABLE OEILLET DE CABLE	1				
5	66M-42119-00	GRIP, STEERING HANDLE POIGNEE, BARRE FRANCHE	1				
6	67D-42177-00	RUBBER, HANDLE CAOUTCHOUC, POIGNEE	1				
7	65W-42138-00	LEVER, THROTTLE LEVIER, ACCELERATEUR	1				
8	90149-05M13	SCREW VIS	1				
9	65W-42159-00	STAY SUPPORT	1				
10	6G1-42126-00	FRICTION, STEERING HANDLE GRIP CUVETTE, POIGNEE DE DIRECTION	1				
11	65W-42125-00	BOLT, FRICTION ADJUSTING BOULON	1				
12	91490-16010	PIN, COTTER GOUPILLE	1				
13	6J0-42137-00	INDICATOR, THROTTLE INDICATEUR, ACCELERATION	1				
14	90269-02M09	RIVET RIVET	1				
15	6X4-44188-00	WASHER RONDELLE	2				
16	90501-23215	SPRING, COMPRESSION RESSORT, COMPRESSION	1				
17	90386-08004	BUSH DOUILLE	1				
18	6AH-26311-00	CABLE, THROTTLE 1 CABLE 1, ACCELERATEUR	2				
19	6AH-44554-00	PLATE PLAQUETTE	1				
20	97095-06014	BOLT BOULON	1				
21	92995-06600	WASHER RONDELLE	1				
22	6AH-2634E-00	PROTECTOR 1 PROTECTEUR 1	1				
23	6AH-42551-00	GROMMET PASSE-FIL	1				
24	90386-45001	BUSH DOUILLE	1				
25	90201-39008	WASHER, PLATE RONDELLE, PLATE	2				
26	90206-39001	WASHER, WAVE RONDELLE, ONDULEE	2				
27	90381-20001	BUSH, SOLID DOUILLE, SOLIDE	1				

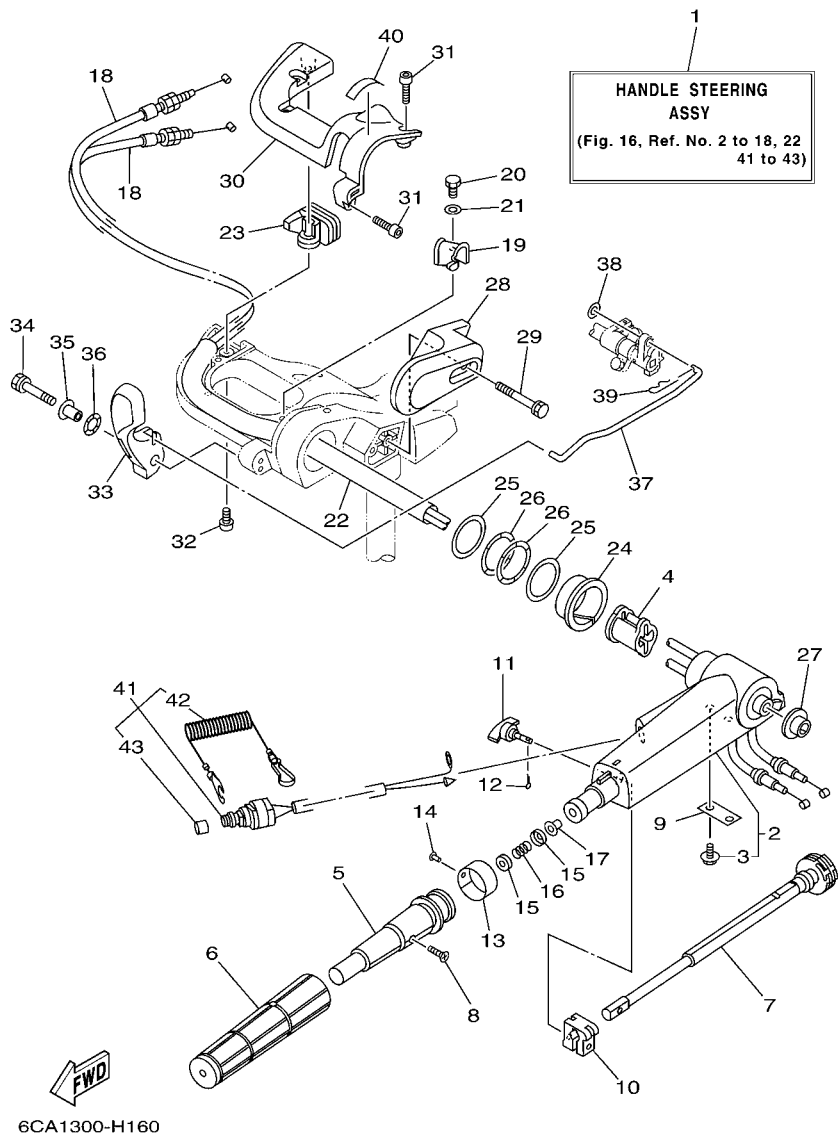

FIG. 16 STEERING

DIRECTION

REF. NO.	PART NO. N° PIECES	DESCRIPTION DESCRIPTION	6CA2				REMARKS REMARQUES
28	6AH-42131-00-4D	COVER, HANDLE STEERING COUVERCLE	1				
29	97595-06555	BOLT, WITH WASHER VIS HEXAGONAL AVC RONDELLE	2				
30	6AH-42532-00	COVER COUVERCLE	1				
31	90111-06072	BOLT, HEX. SOCKET BUTTON BOULON	4				
32	97780-60520	SCREW, TAPPING VIS, TETE BOMBEE	1				
33	6AH-44111-00	HANDLE, GEAR SHIFT POIGNEE, LEVIER D'EMBRAYAGE	1				
34	90119-06M05	BOLT, WITH WASHER BOULON, AVEC RONDELLE	1				
35	90387-06M86	COLLAR COLLERETTE	1				
36	90206-15M18	WASHER, WAVE RONDELLE, ONDULEE	1				
37	6AH-44124-00	LINK, SHIFT ROD BIELLETTTE	1				
38	92990-06200	WASHER, PLAIN RONDELLE, PLATE	1				
39	90468-18008	CLIP JONC	1				
40	6G8-44191-00	INDICATOR, SHIFT ETIQUETTE, EMBRAYAGE	1				
41	6AH-82575-00	ENGINE STOP SWITCH ASSY COUPE CIRCUIT CPLT	1				
42	682-82556-00	.LANYARD, STOP SWITCH .PLAQUETTE	1				
43	689-8257Y-00	.CAP .COUVERCLE	1				

FIG. 17 STEERING FRICTION

CUVETTE POIGNEE DE DIRECTION

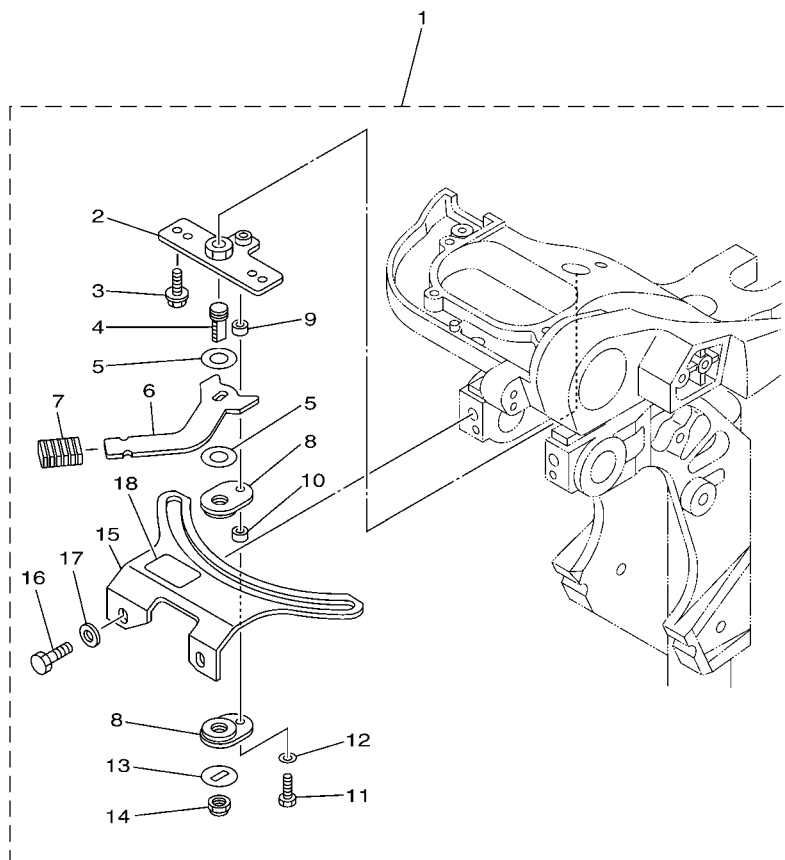

REF. NO.	PART NO. N° PIECES	DESCRIPTION DESCRIPTION	6CA2				REMARKS REMARQUES
1	6AH-42508-00	STEERING FRICTION ASSY DIRECTION FRICTION (ENS.)	1				
2	68T-42525-01	.PLATE, FRICTION .PLAQUE, FRICTION	1				
3	90119-05018	.BOLT, WITH WASHER .BOULON, AVEC RONDELLE	2				
4	67C-42562-00	.SHAFT, STEERING LOCK .ARBRE, ANTIVOL DE DIRECTION	1				
5	90202-10M56	.WASHER, PLATE .RONDELLE, PLATE	2				
6	68T-42561-00	.KNOB, STEERING LOCK .BOUTON	1				
7	689-43633-00	.COVER, TILT LEVER .COUVERCLE	1				
8	65W-42528-00	.PLATE, FRICTION .PLAQUE, FRICTION	2				
9	90387-05M05	.COLLAR .COLLERETTE	1				
10	90387-05M11	.COLLAR .COLLERETTE	1				
11	97095-05020	.BOLT .BOULON	1				
12	92995-05600	.WASHER .RONDELLE	1				
13	90209-10M26	.WASHER .RONDELLE	1				
14	90185-10M14	.NUT, SELF-LOCKING .ECROU, AUTO-BLOQUANT	1				
15	6AH-42527-00	.PLATE, FRICTION .PLAQUE, FRICTION	1				
16	90101-08022	.BOLT .BOULON	2				
17	90201-08065	.WASHER, PLATE .RONDELLE, PLATE	2				
18	68T-43155-00	.MARK 1 .ETIQUETTE 1	1				

  
6AH1100-F210

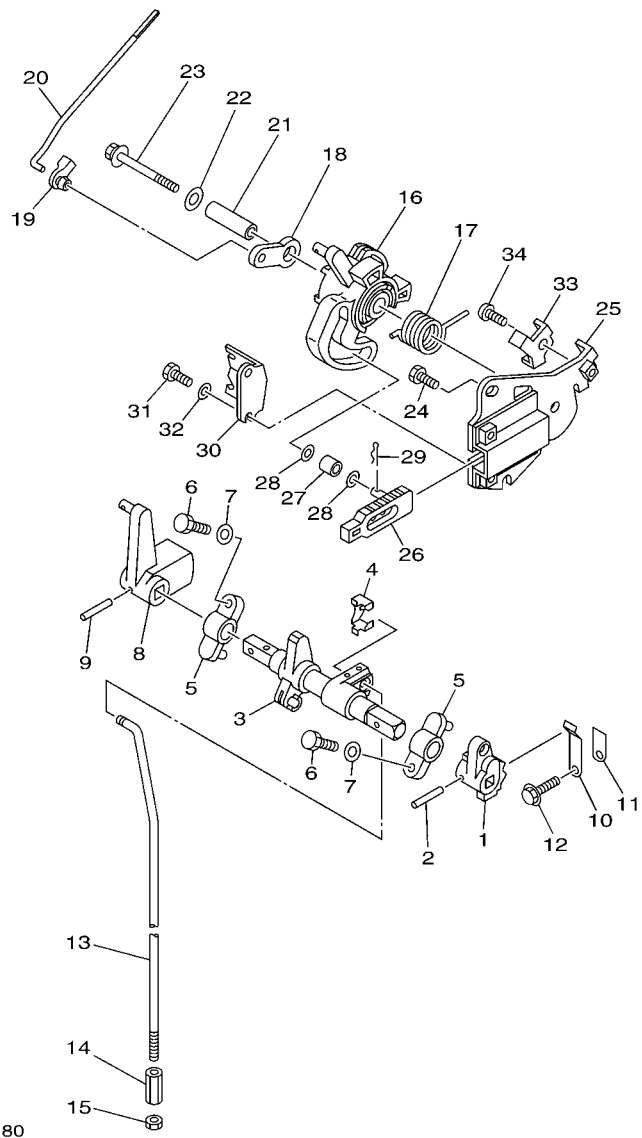
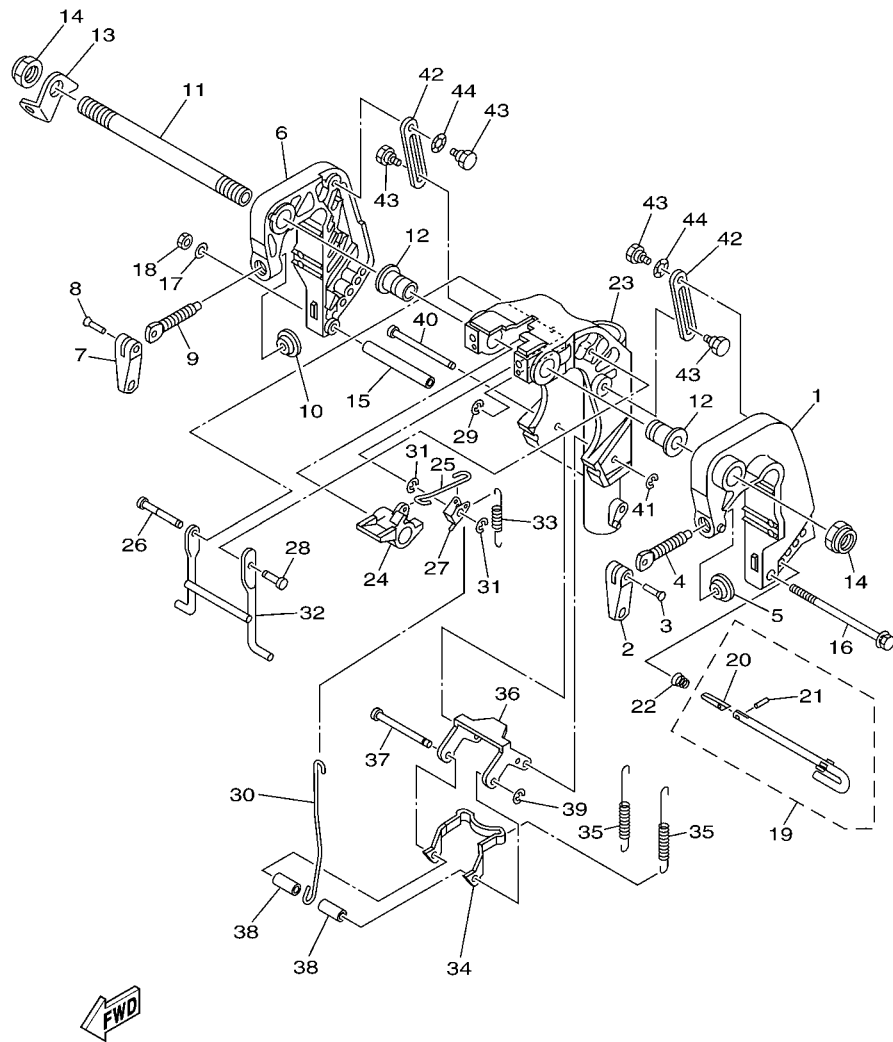

FIG. 18 CONTROL

COMMANDE

REF. NO.	PART NO. N° PIECES	DESCRIPTION DESCRIPTION	6CA2				REMARKS REMARQUES
1	6AH-44123-00	ARM, SHIFT ROD BRAS, TIGE D'INVERSION	1				
2	90254-03M05	PIN, SPRING RIVET, TETE TRONCONIQUE	1				
3	6AH-44121-00	LEVER, SHIFT ROD LEVIER, TIGE D'INVERSION	1				
4	6AH-26364-00	END, CABLE 2 EMBOUIT, DE CABLE	1				
5	6G1-41662-01-94	BRACKET 2 SUPPORT 2	2				
6	97095-06020	BOLT BOULON	2				
7	92995-06600	WASHER RONDELLE	2				
8	6AH-44125-00	LEVER, SHIFT ROD LEVIER, TIGE D'INVERSION	1				
9	90254-03M05	PIN, SPRING RIVET, TETE TRONCONIQUE	1				
10	65W-44116-00	SPRING RESSORT	1				
11	66R-44114-00	STOPPER PLAQUETTE	1				
12	95895-06014	BOLT, FLANGE BOULON	1				
13	6AH-44143-00	ROD, SHIFT TIGE D'EMBAYAGE	1				S(17.1")
	6AH-44143-10	ROD, SHIFT TIGE D'EMBAYAGE	1				L(22.1")
14	90170-06015	NUT ECROU	1				L(22.1")
15	95380-06700	NUT ECROU	1				
16	6AH-41638-00	PULLEY POULIE	1				
17	90508-20M44	SPRING, TORSION RESSORT, TORSION	1				
18	65W-41283-00	LEVER, FREE ACCEL. LEVIER	1				
19	6J8-41262-00	JOINT, CHOKE LEVER RACCORD, LEVIER DE STARTER	1				
20	6AH-41211-00	LINK, ACCEL. BIELLETTE, ACCELERATION	1				
21	90387-06139	COLLAR COLLERETTE	1				
22	90201-06M31	WASHER, PLATE RONDELLE, PLATE	1				
23	97595-06555	BOLT, WITH WASHER VIS HEXAGONAL AVC RONDELLE	1				
24	97095-06014	BOLT BOULON	2				
25	6AH-14571-10	BRACKET, THROTTLE SUPPORT, ACCELERATEUR	1				
26	6AH-44167-00	PLUNGER, SHIFT CAM POUSOIR D'EMBAYAGE	1				





6AH1300-F230

FIG. 19 BRACKET 1

SUPPORT 1

REF. NO.	PART NO. N° PIECES	DESCRIPTION DESCRIPTION	6CA2				REMARKS REMARQUES
1	6AH-43111-00-4D	BRACKET, CLAMP 1 PRESSE 1	1				
2	6E0-43118-01	HANDLE, TRANSOM CLAMP POIGNEE DE VIS DE PRESSE	1				
3	90243-04M01	PIN GOUPILLE	1				
4	6E7-43116-00	SCREW, TRANSOM CLAMP VIS DE PRESSE	1				
5	648-43114-01	PAD, TRANSOM CLAMP RONDELLE D'APPUI	1				
6	6AH-43112-00-4D	BRACKET, CLAMP 2 PRESSE 2	1				
7	6E0-43118-01	HANDLE, TRANSOM CLAMP POIGNEE DE VIS DE PRESSE	1				
8	90243-04M01	PIN GOUPILLE	1				
9	6E7-43116-00	SCREW, TRANSOM CLAMP VIS DE PRESSE	1				
10	648-43114-01	PAD, TRANSOM CLAMP RONDELLE D'APPUI	1				
11	69A-43131-00	BOLT, CLAMP BRACKET BOULON, PRESSE	1				FOR REMOTE CONTROL FOR REMOTE CONTROL
12	90386-22MA4	BUSH DOUILLE	2				
13	66R-43113-00	PLATE, CLAMP BRACKET PLAQUETTE, PRESSE	1				
14	90185-22043	NUT, SELF-LOCKING ECROU, AUTO-BLOQUANT	2				
15	90387-06M13	COLLAR COLLERETTE	1				
16	90101-06M18	BOLT BOULON	1				
17	92990-06600	WASHER, PLATE RONDELLE, PLATE	1				
18	95380-06700	NUT ECROU	1				
19	6L2-43160-01	TILT ROD ASSY BROCHE D'INCLINAISON (ENS.)	1				
20	689-43165-00	.PLATE, TILT LOCK .TAQUET, BROCHE INCLINAISON	1				
21	91690-30008	.PIN, SPRING .AGRAFFE	1				
22	90502-10M07	SPRING, CONICAL RESSORT, CONIQUE	1				
23	6AH-43311-00-4D	BRACKET, SWIVEL 1 SUPPORT, PIVOT 1	1				S(17.1") S(17.1")
	6AH-43311-10-4D	BRACKET, SWIVEL 1 SUPPORT, PIVOT 1	1				L(22.1") L(22.1")
24	6AH-43631-00	LEVER, TILT LEVIER, INCLINAISON	1				
25	6AH-43616-00	ROD, TILT LOCK TIGE	1				
26	6AH-43646-00	SHAFT, LEVER AXE, LEVER	1				

FIG. 19 BRACKET 1

SUPPORT 1

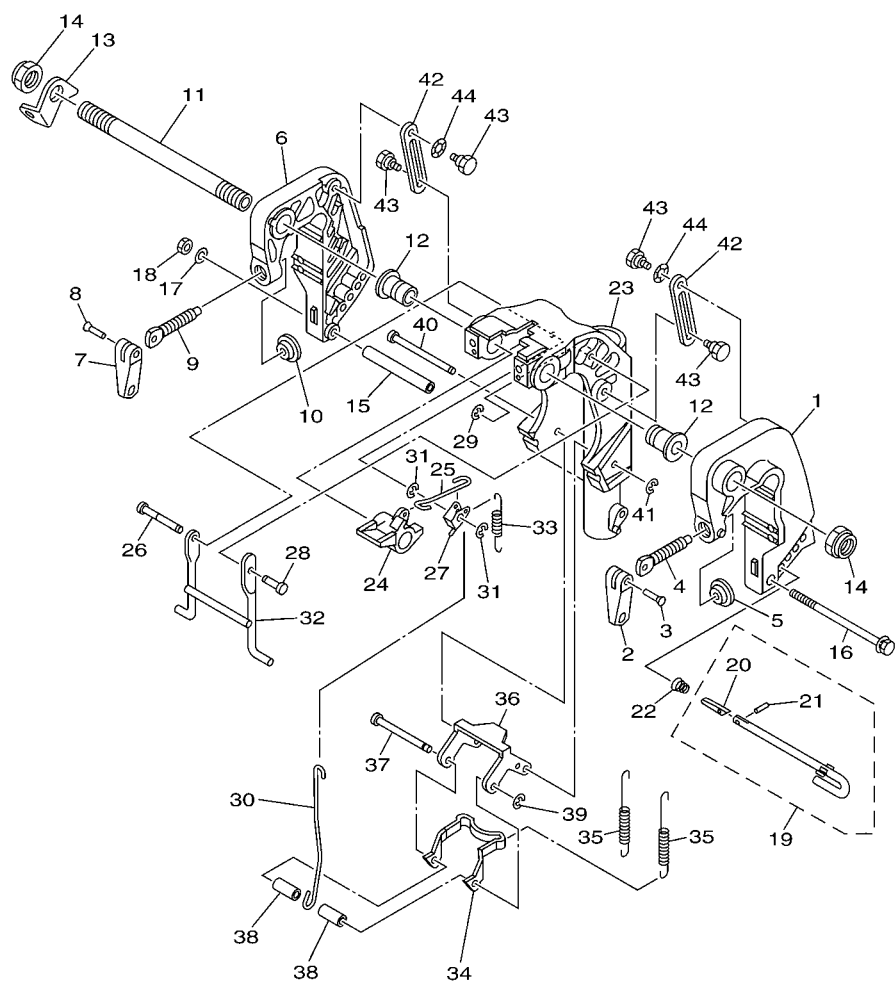

FWD  
6AH1300-F230

REF. NO.	PART NO. N° PIECES	DESCRIPTION DESCRIPTION	6CA2				REMARKS REMARQUES
27	6AH-43641-00	LEVER, TILT LEVIER, INCLINAISON	1				
28	6AH-43191-00	SHAFT, STOPPER AXE, BUTEE	1				
29	99080-05600	CIRCLIP CIRCLIP	1				
30	6AH-43617-00	ROD, TILT LOCK TIGE	1				
31	99080-05600	CIRCLIP CIRCLIP	2				
32	6AH-43350-00	RECEIVER ASSY RECEIVER ASSY	1				
33	90506-18014	SPRING, TENSION RESSORT, TENSION	1				
34	6AH-43614-00	PLATE, TILT LOCK ETRIER, VERROUILLAGE MARCHE AR	1				
35	90506-20020	SPRING, TENSION RESSORT, TENSION	2				
36	6AH-43615-00	PLATE, TILT LOCK ETRIER, VERROUILLAGE MARCHE AR	1				
37	68T-43611-00	SHAFT, TILT LOCK AXE, VERROUILLAGE MARCHE AR	1				
38	90387-06138	COLLAR COLLERETTE	2				
39	93430-04M03	CIRCLIP CLIPS	1				
40	68T-43659-00	SHAFT, REVERSE LOCK AXE, VERROUILLAGE MARCHE AR	1				
41	99080-05600	CIRCLIP CIRCLIP	1				
42	6AH-43627-00	STOPPER PLAQUETTE	2				
43	90109-06M84	BOLT BOULON	4				
44	90206-10M24	WASHER, WAVE RONDELLE, ONDULEE	2				

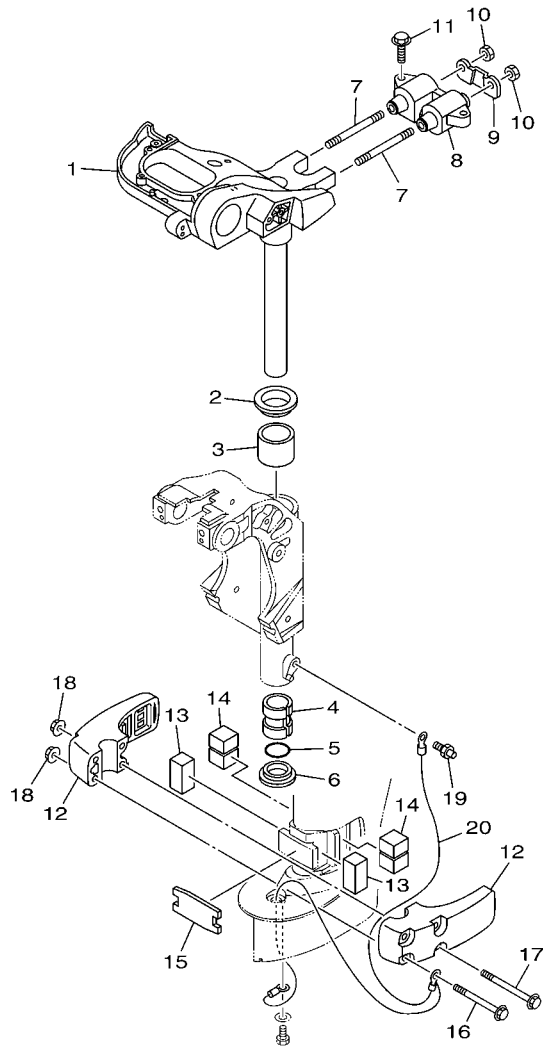

6CA1300-H200

FIG. 20 BRACKET 2

SUPPORT 2

REF. NO.	PART NO. N° PIECES	DESCRIPTION DESCRIPTION	6CA2			REMARKS REMARQUES
1	6AH-42510-00-4D	STEERING BRACKET ASSY DIRECTION SUPPORT (ENS.)	1			S(17.1") S(17.1")
	6AH-42510-10-4D	STEERING BRACKET ASSY DIRECTION SUPPORT (ENS.)	1			L(22.1") L(22.1")
2	90209-40008	WASHER RONDELLE	1			
3	90386-40001	BUSH DOUILLE	1			
4	90386-30048	BUSH DOUILLE	1			
5	93210-29M94	O-RING JOINT TORIQUE	1			
6	90386-30M60	BUSH DOUILLE	1			
7	90116-10033	BOLT, STUD GOIJON	2			
8	6AH-44514-00-94	MOUNT DAMPER, UPPER SIDE SILENT-BLOC, SUPERIEUR LATERAL	1			
9	6AH-44526-00	PLATE PLAQUE	1			
10	95380-10600	NUT ECROU	2			
11	90119-08094	BOLT, WITH WASHER BOULON, AVEC RONDELLE	2			
12	6AH-44551-00-4D	HOUSING, LOWER MOUNT RUBBER BOITIER, SILENT-BLOC INFERIEUR	2			
13	6AH-44557-00	MOUNT DAMPER, LOWER FRONT SILENT-BLOC, INFERIEUR AVANT	2			
14	6AH-44555-00	MOUNT DAMPER, LOWER SIDE SILENT-BLOC, INFERIEUR LATERAL	2			
15	6AH-44574-00	STOPPER, LOWER MOUNT RUBBER BUTEE	1			
16	90119-08M45	BOLT, WITH WASHER BOULON, AVEC RONDELLE	2			
17	90119-08M46	BOLT, WITH WASHER BOULON, AVEC RONDELLE	2			
18	90179-08M34	NUT ECROU	4			
19	93700-06M03	NIPPLE, GREASE PION	1			
20	6AH-82127-00	WIRE, LEAD 2 FIL 2	1			

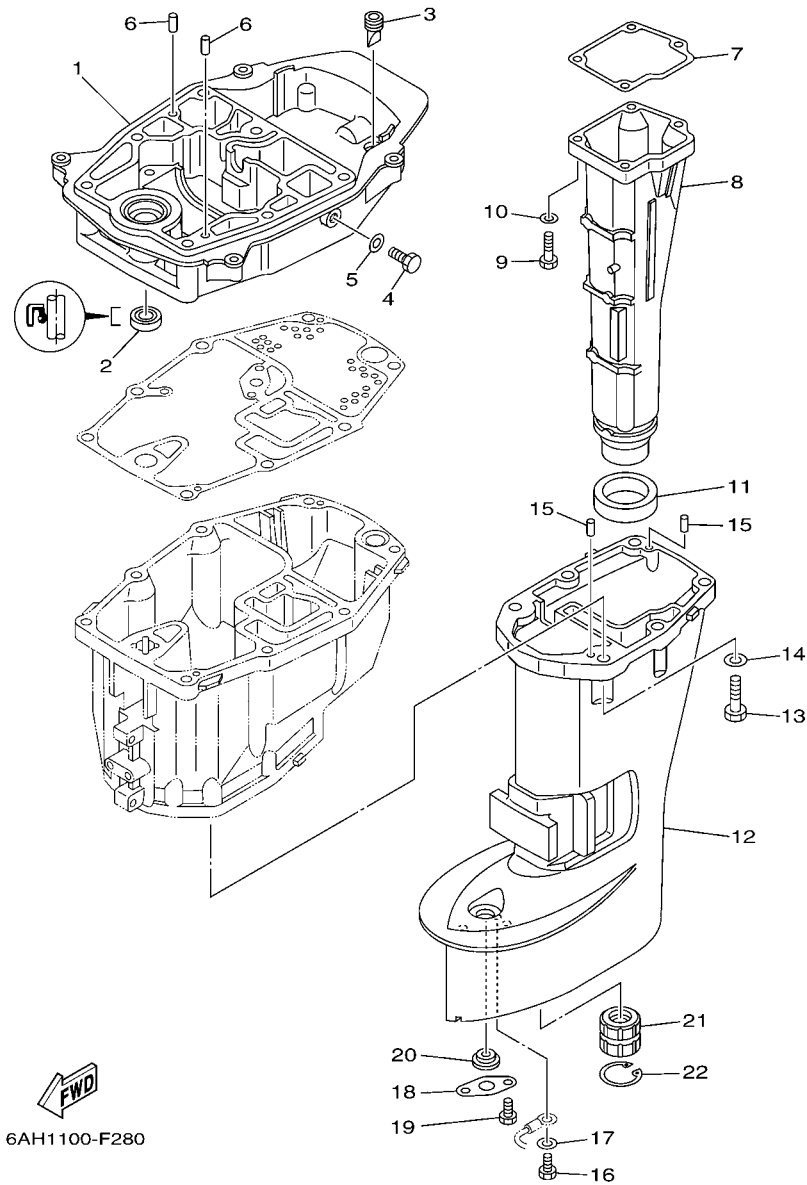

6AH1100-F280

FIG. 21 UPPER CASING

FOURREAU

REF. NO.	PART NO. N° PIECES	DESCRIPTION DESCRIPTION	6CA2			REMARKS REMARQUES
1	6AH-41137-00-5B	GUIDE, EXHAUST COLLECTEUR D'ECHAPPEMENT	1			
2	93101-12M63	OIL SEAL JOINT SPY	1			
3	65W-42717-00	RUBBER, SEAL 2 JOINT EN CAOUTCHOUC 2	1			
4	97095-08014	BOLT BOULON	1			
5	90430-08143	GASKET JOINT	1			
6	93606-19M23	PIN, DOWEL GOUPILLE	2			
7	6AH-41134-00	GASKET, EXHAUST MANIFOLD JOINT, PIPE D'ECHAPPEMENT	1			
8	6AH-14711-00-5B	MUFFLER 1 POT D'ECHAPPEMENT 1	1			S(17.1")
	6AH-14711-10-5B	MUFFLER 1 POT D'ECHAPPEMENT 1	1			S(17.1") L(22.1")
9	97075-06025	BOLT BOULON	4			L(22.1")
10	92995-06600	WASHER RONDELLE	4			
11	6AH-41138-00	SEAL, EXT. 1 JOINT DE GROUPE 1	1			
12	6AH-45111-00-4D	CASING, UPPER FOURREAU	1			S(17.1")
	6AH-45111-10-4D	CASING, UPPER FOURREAU	1			S(17.1") L(22.1")
13	97075-08030	BOLT BOULON	6			
14	92995-08600	WASHER RONDELLE	6			
15	93604-12M07	PIN, DOWEL CLAVETTE	2			
16	97095-05010	BOLT BOULON	1			
17	92995-05600	WASHER RONDELLE	1			
18	68T-45321-00	PLATE PLAQUETTE	1			
19	97095-06008	BOLT BOULON	1			
20	90480-14M54	GROMMET PASSE-FIL	1			
21	682-45318-00	BUSHING, DRIVE SHAFT DOUILLE, ARBRE MOTEUR	1			L(22.1")
22	93420-30042	CIRCLIP CIRCLIP, TYPE S	1			L(22.1") L(22.1")

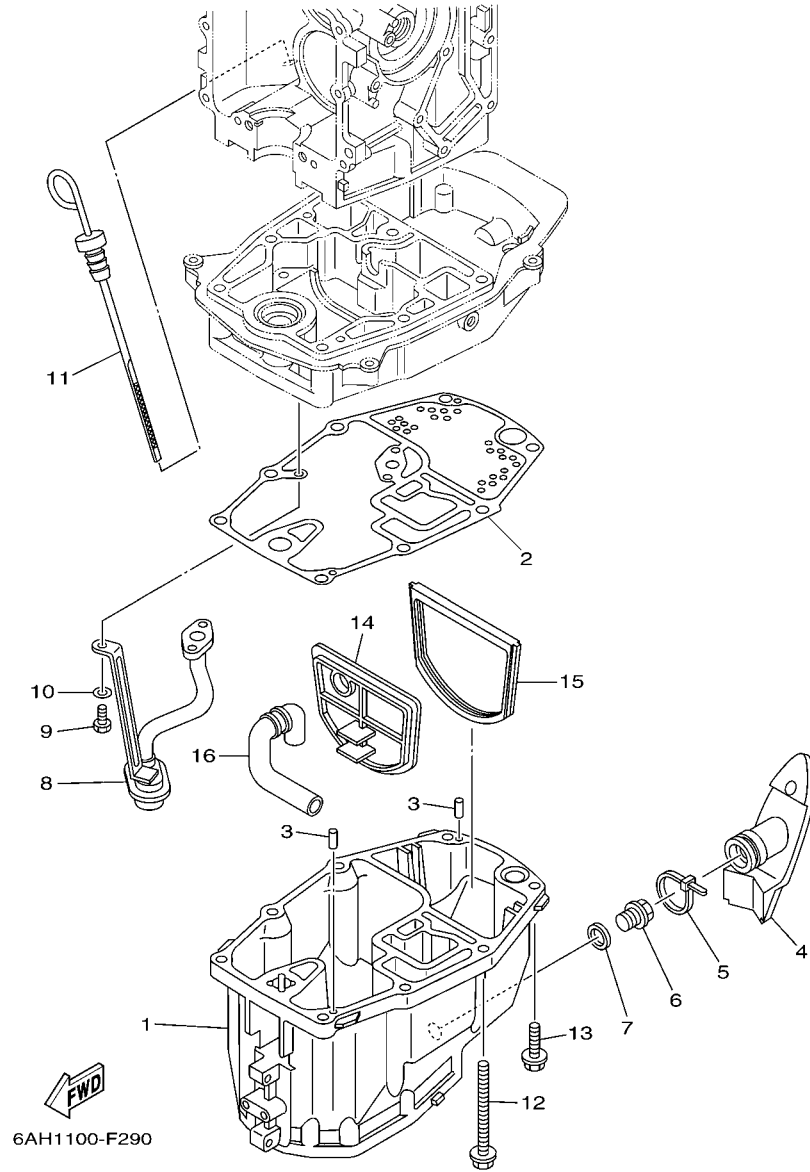

FIG. 22 OIL PAN

VENTILATEUR D'HUILE

REF. NO.	PART NO. N° PIECES	DESCRIPTION DESCRIPTION	6CA2				REMARKS REMARQUES
1	6AH-15311-00-5B	OIL PAN VENTILATEUR D'HUILE	1				
2	6AH-15312-00	GASKET, OIL PAN JOINT DE VENTILATEUR D'HUILE	1				
3	93604-12M07	PIN, DOWEL CLAVETTE	2				
4	6AH-15316-00	DAMPER 1 AMORTISSEUR 1	1				
5	90465-11M59	CLAMP BRIDE	1				
6	90340-14M06	PLUG, STRAIGHT SCREW PLOT, FILETE DROIT	1				
7	90430-14M09	GASKET JOINT	1				
8	6AH-13411-00	STRAINER, OIL FILTRE, HUILE	1				
9	97013-06016	BOLT BOULON	3				
10	92903-06600	WASHER, PLATE RONDELLE, PLATE	3				
11	6AH-15362-00	PLUG, OIL LEVEL PLOT, NIVEAU D'HUILE	1				
12	90119-08103	BOLT, WITH WASHER BOULON, AVEC RONDELLE	6				
13	90119-08102	BOLT, WITH WASHER BOULON, AVEC RONDELLE	2				
14	6AH-45126-00	PLATE, SEAL DAMPER PLAQUETTE	1				
15	6AH-45115-00	GASKET, UPPER CASING JOINT, TUBE D'ARBRE	1				
16	6AH-45135-00	PIPE TUYAU	1				

FIG. 23 LOWER CASING & DRIVE 1

BOITIER D'HELICE TRANSMISSION1

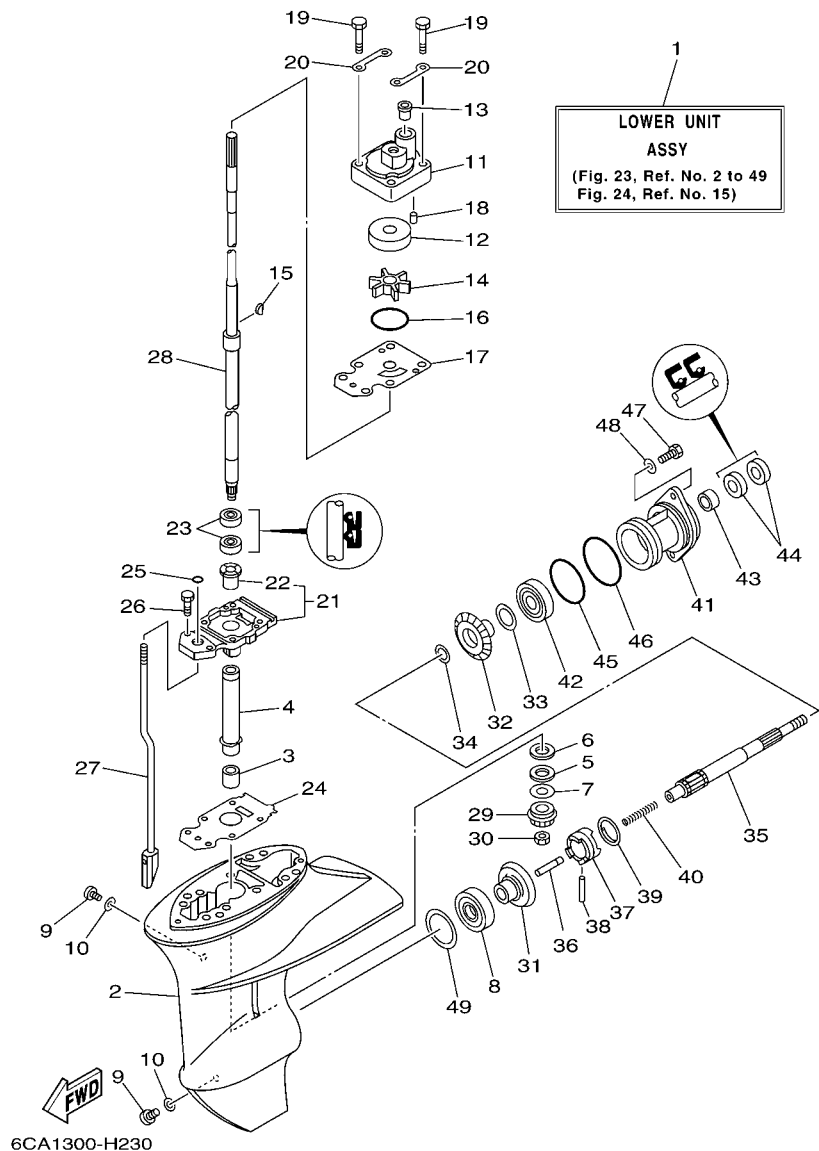

REF. NO.	PART NO. N° PIECES	DESCRIPTION DESCRIPTION	6CA2			REMARKS REMARQUES
1	6AH-45300-00-4D	LOWER UNIT ASSY UNITE INFERIEURE (ENS.)	1			S(17.1") S(17.1")
	6AH-45300-10-4D	LOWER UNIT ASSY UNITE INFERIEURE (ENS.)	1			L(22.1") L(22.1")
2	6AH-45311-00-4D	CASING, LOWER BOITIER D'HELICE	1			
3	93315-314V8	BEARING ROULEMENT	1			
4	63V-45536-00	SLEEVE, DRIVE SHAFT MANCHON, ARBRE MOTEUR	1			
5	90209-14011	WASHER RONDELLE	1			
6	90201-15017	WASHER, PLATE RONDELLE, PLATE	1			
7	6E8-45587-10	SHIM (T:1.13MM) CALE (T:1.13MM)	1			UR
	6E8-45587-30	SHIM (T:1.20MM) CALE (T:1.20MM)	1			UR
8	93332-00005	BEARING ROULEMENT	1			
9	90340-08002	PLUG, STRAIGHT SCREW PLOT, FILETE DROIT	2			
10	90430-08020	GASKET JOINT	2			
11	6AH-44311-00	HOUSING, WATER PUMP CORPS, POMPE A EAU	1			
12	63V-44322-00	INSERT, CARTRIDGE CUVETTE	1			
13	6L2-44367-00	DAMPER, WATER SEAL JOINT TUBE D'EAU	1			
14	63V-44352-01	IMPPELLER TURBINE	1			
15	664-44338-00	KEY, WOODRUFF CLAVETTE, VOLANT	1			
16	93210-49046	O-RING JOINT TORIQUE	1			
17	68T-44323-00	OUTER PLATE, CARTRIDGE PLAQUE EXTERIEURE	1			
18	93604-12M07	PIN, DOWEL CLAVETTE	2			
19	97080-08045	BOLT BOULON	4			
20	63V-44328-00	PLATE PLAQUETTE	2			
21	69G-45331-01-5B	HOUSING, BEARING FLASQUE, ROULEMENT	1			
22	626-45316-09	BUSHING, DRIVE SHAFT DOUILLE, ARBRE MOTEUR	1			
23	93101-20001	OIL SEAL JOINT SPY	2			
24	69G-45315-A0	PACKING, LOWER CASING JOINT, BOITIER D'HELICE	1			
25	93210-06ME6	O-RING JOINT TORIQUE	1			

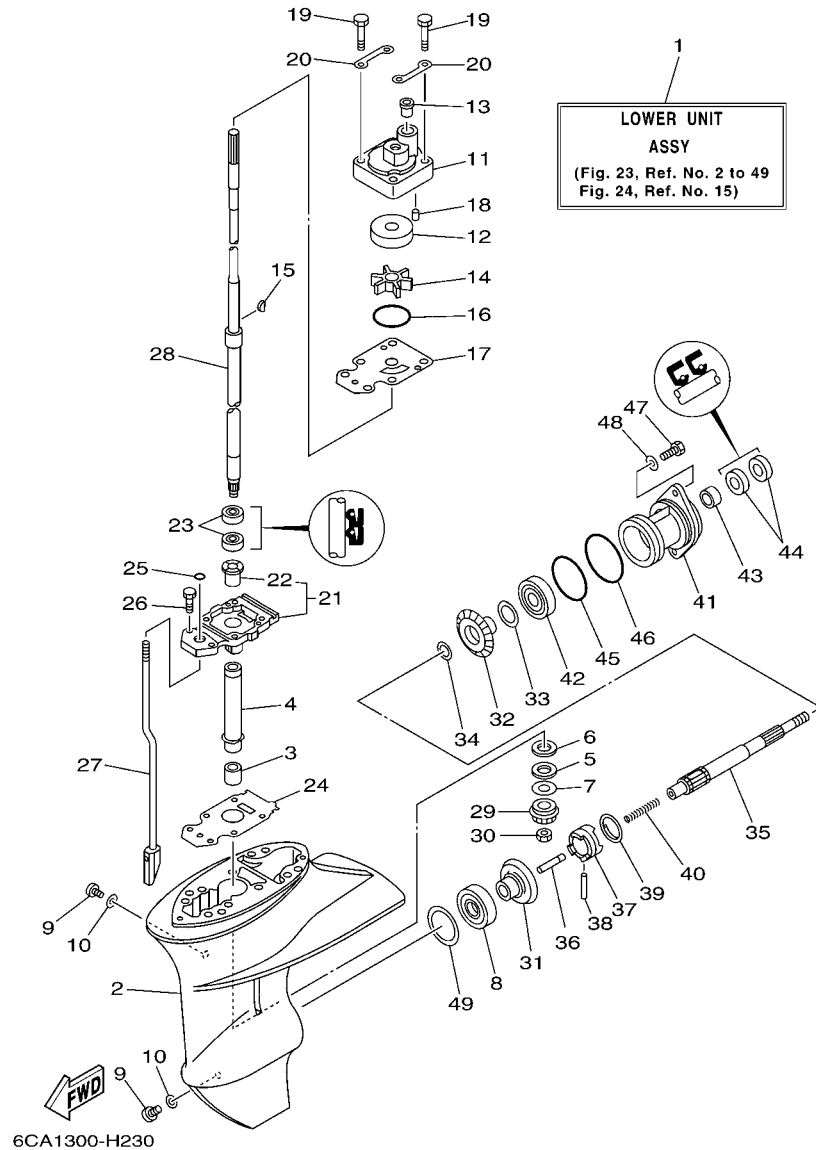

FIG. 23 LOWER CASING & DRIVE 1

BOITIER D'HELICE TRANSMISSION1

REF. NO.	PART NO. N° PIECES	DESCRIPTION DESCRIPTION	6CA2				REMARKS REMARQUES
26	97080-08025	BOLT BOULON	2				
27	6AH-44150-00	SHIFT CAM ASSY CAME D'INVERSION	1				S(17.1") S(17.1")
	6AH-44150-10	SHIFT CAM ASSY CAME D'INVERSION	1				L(22.1") L(22.1")
28	6AH-45510-00	DRIVE SHAFT ASSY ARBRE MOTEUR (ENS.)	1				S(17.1") S(17.1")
	6AH-45510-10	DRIVE SHAFT ASSY ARBRE MOTEUR (ENS.)	1				L(22.1") L(22.1")
29	63V-45551-00	PINION (13T) PIGNON D'ATTAQUE (13D)	1				
30	90179-08M06	NUT ECROU	1				
31	6E7-45560-01	GEAR 1 (27T) PIGNON 1 (27T)	1				
32	6E7-45571-00	GEAR 2 (27T) PIGNON 2 (27T)	1				
33	626-45577-00	SHIM (T:0.10MM) CALE (T:0.10MM)	1				UR UR
	626-45577-10	SHIM (T:0.20MM) CALE (T:0.20MM)	1				UR UR
	626-45577-20	SHIM (T:0.30MM) CALE (T:0.30MM)	1				UR UR
	626-45577-30	SHIM (T:0.40MM) CALE (T:0.40MM)	1				UR UR
	626-45577-40	SHIM (T:0.50MM) CALE (T:0.50MM)	1				UR UR
34	90201-17682	WASHER, PLATE RONDELLE, PLATE	1				
35	683-45611-00	SHAFT, PROPELLER ARBRE, HELICE	1				
36	650-45635-00	PLUNGER, SHIFT POUSSOIR D'EMBRAYAGE	1				
37	682-45631-00	CLUTCH, DOG CRABOT	1				
38	90250-05010	PIN, STRAIGHT GOUPILLE, DROITE	1				
39	648-45633-00	RING, CROSS PIN JONC, GOUPILLE CRABOT	1				
40	90501-150A0	SPRING, COMPRESSION RESSORT, COMPRESSION	1				
41	683-45361-02-4D	CAP, LOWER CASING COUVERCLE, BOITIER D'HELICE	1				
42	93306-00501	BEARING ROULEMENT	1				
43	93315-317U2	BEARING ROULEMENT	1				
44	93101-17054	OIL SEAL JOINT SPY	2				
45	93210-57M09	O-RING JOINT TORIQUE	1				
46	93210-56M80	O-RING JOINT TORIQUE	1				

FIG. 23 LOWER CASING & DRIVE 1

BOITIER D'HELICE TRANSMISSION1

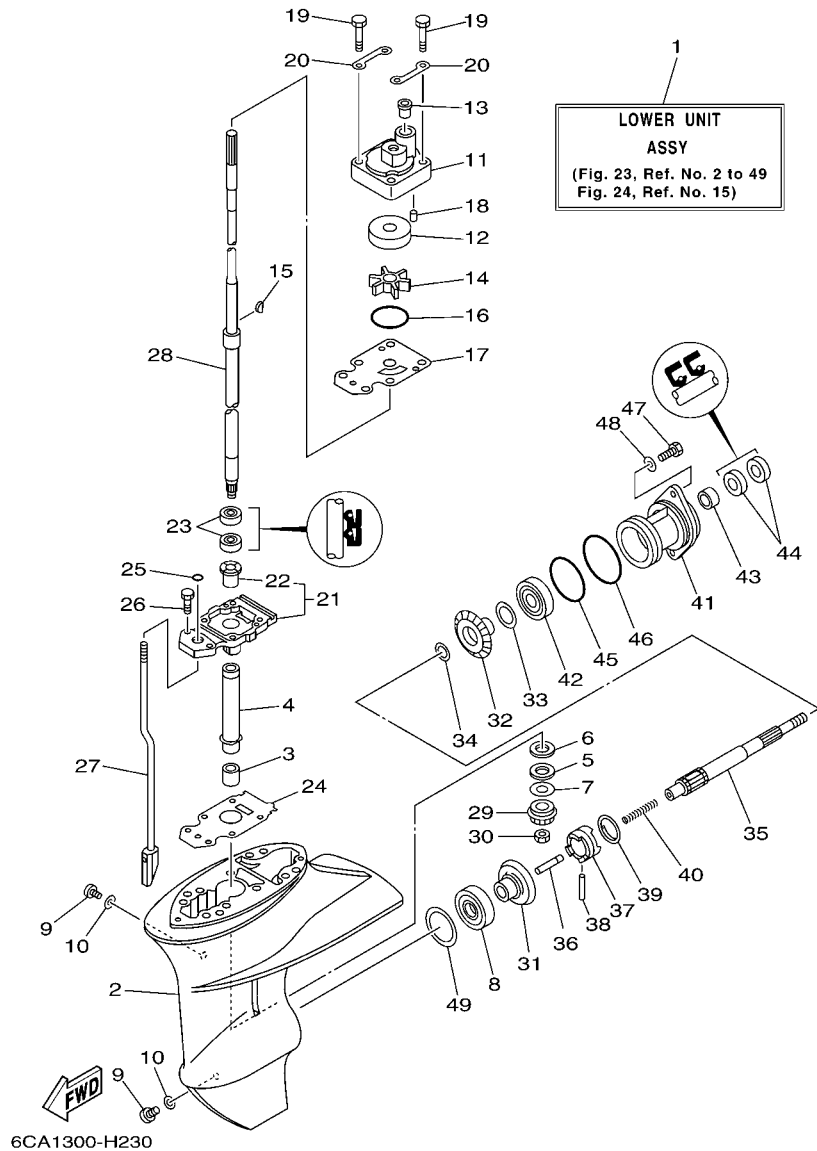

REF. NO.	PART NO. N° PIECES	DESCRIPTION DESCRIPTION	6CA2				REMARKS REMARQUES
47	97075-06020	BOLT BOULON	2				
48	92995-06600	WASHER RONDELLE	2				
49	664-45567-01	SHIM (T:0.10MM) CALE (T:0.10MM)	1				UR UR
	664-45567-10	SHIM (T:0.12MM) CALE (T:0.12MM)	1				UR UR
	664-45567-20	SHIM (T:0.15MM) CALE (T:0.15MM)	1				UR UR
	664-45567-30	SHIM (T:0.18MM) CALE (T:0.18MM)	1				UR UR
	664-45567-40	SHIM (T:0.30MM) CALE (T:0.30MM)	1				UR UR
	664-45567-50	SHIM (T:0.40MM) CALE (T:0.40MM)	1				UR UR
	664-45567-60	SHIM (T:0.50MM) CALE (T:0.50MM)	1				UR UR

FIG. 24 LOWER CASING & DRIVE 2

BOITIER D'HELICE TRANSMISSION2

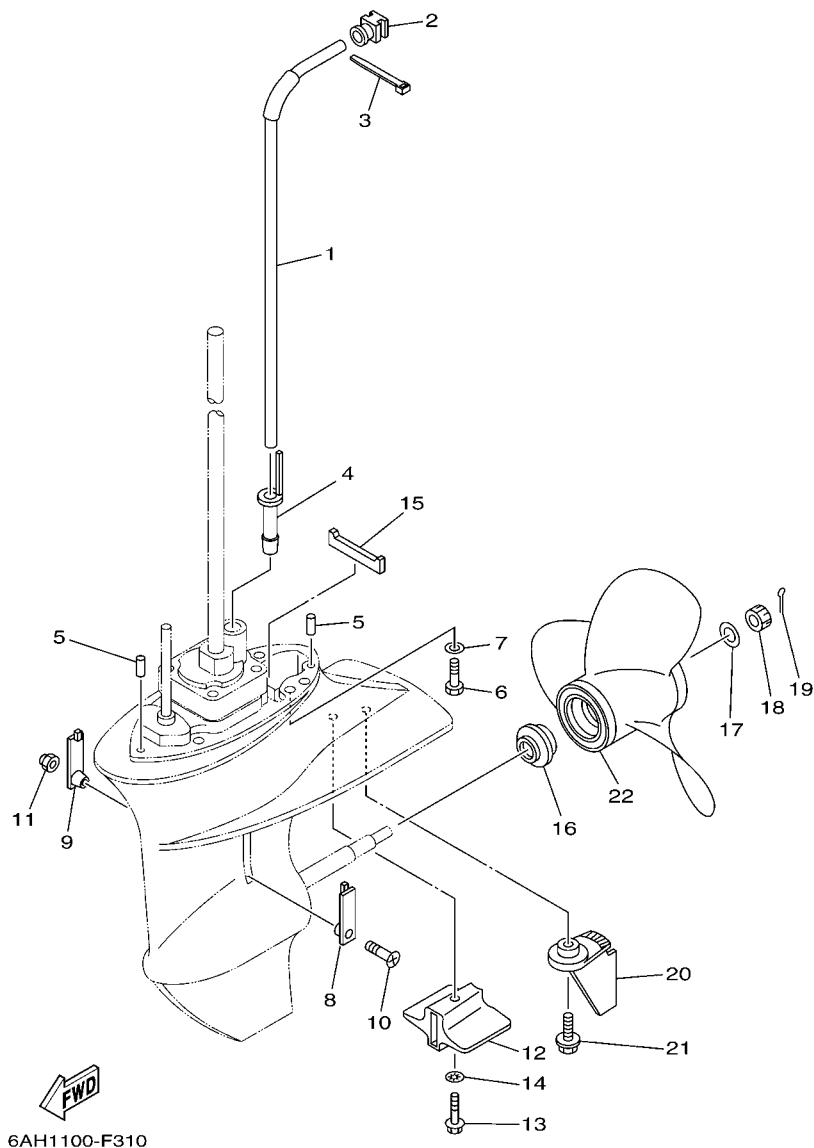

6AH1100-F310

REF. NO.	PART NO. N° PIECES	DESCRIPTION DESCRIPTION	6CA2			REMARKS REMARQUES
1	6AH-44361-00	TUBE, WATER TUBE D'EAU	1			S(17.1") S(17.1")
	6AH-44361-10	TUBE, WATER TUBE D'EAU	1			L(22.1") L(22.1")
2	6AH-44365-00	DAMPER, WATER SEAL JOINT, TUBE D'EAU	1			
3	90465-11M10	CLAMP BRIDE	1			
4	6AH-44368-00	RUBBER, WATER SEAL 4 CAOUTCHOUC EAU JUNTA 4	1			
5	93604-12M07	PIN, DOWEL CLAVETTE	2			
6	97075-08030	BOLT BOULON	4			
7	92995-08600	WASHER RONDELLE	4			
8	6G1-45214-00	COVER, WATER INLET 1 GRILLE, ENTREE D'EAU 1	1			
9	63V-45215-00	COVER, WATER INLET 2 GRILLE, ENTREE D'EAU 2	1			
10	90152-05M04	SCREW, COUNTERSUNK VIS, TETE NOYEE	1			
11	90185-05002	NUT, NYLON ECROU,AUTO-BLOQUANT	1			
12	6AH-45251-00	ANODE ANODE	1			
13	95895-06035	BOLT, FLANGE BOULON	1			
14	92990-06300	WASHER, INTERNAL TOOTH RONDELLE, DENTURE INTERNE	1			
15	63V-45375-00	DAMPER, SEAL BOURRELET, CAOUTCHOUC	1			
16	6E7-45987-01	SPACER ENTRETOISE	1			
17	90201-10M01	WASHER, PLATE RONDELLE, PLATE	1			
18	90171-10M01	NUT, CASTLE ECROU, CRENELE	1			
19	91490-30020	PIN. COTTER GOUPILLE	1			
20	6AH-45371-00-4D	TAB-TRIM ANODE DERIVE	1			
21	90119-06M88	BOLT, WITH WASHER BOULON, AVEC RONDELLE	1			
22	63V-45941-10-EL	PROPELLER (3X9-1/4"X12"-J1) HELICE (3X9-1/4"X12"-J1)	1			UR UR
	63V-45943-10-EL	PROPELLER (3X9-1/4"X11"-J1) HELICE (3X9-1/4"X11"-J1)	1			UR UR
	63V-45945-10-EL	PROPELLER (3X9-1/4"X9"-J1) HELICE (3X9-1/4"X9"-J1)	1			UR UR
	63V-45952-10-EL	PROPELLER (3X9-1/4"X10"-J1) HELICE (3X9-1/4"X10"-J1)	1			UR UR
	683-45941-00-EL	PROPELLER (3X9-1/4"X12"-J) HELICE (3X9-1/4"X12"-J)	1			UR UR

FIG. 24 LOWER CASING & DRIVE 2

BOITIER D'HELICE TRANSMISSION2

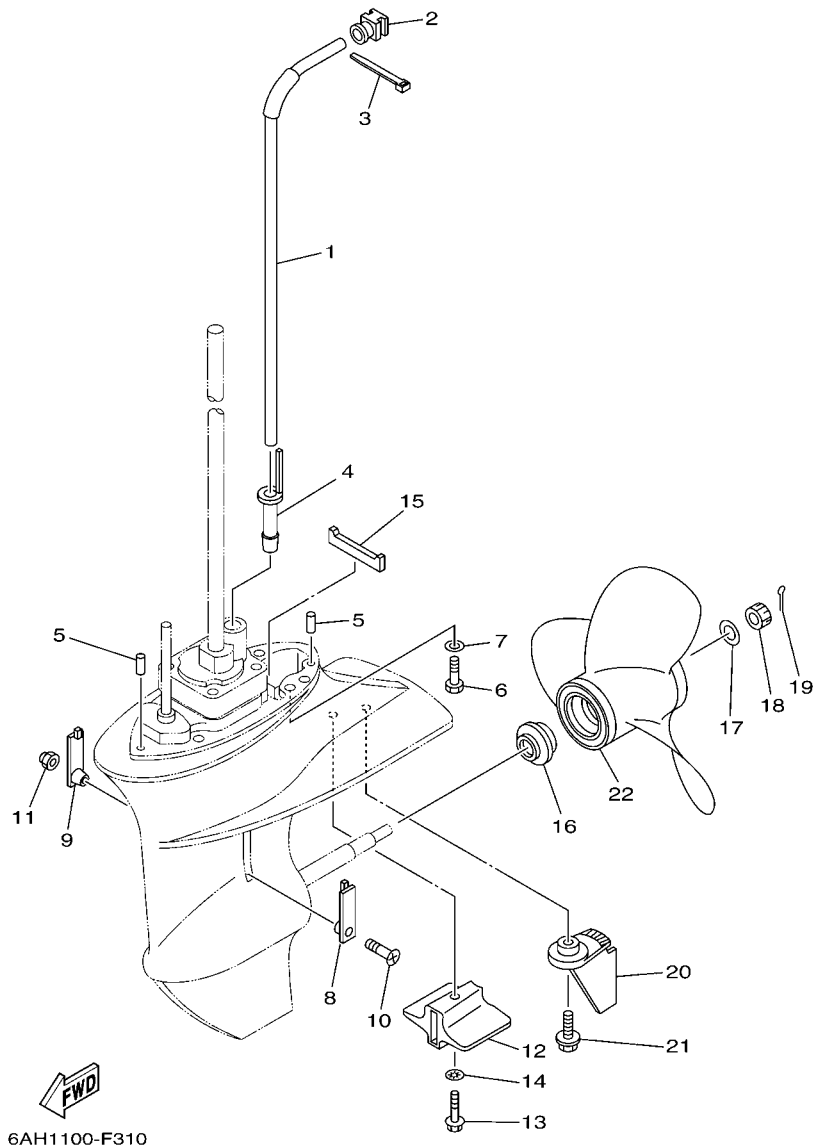

REF. NO.	PART NO. N° PIECES	DESCRIPTION DESCRIPTION	6CA2				REMARKS REMARQUES
22	683-45943-00-EL	PROPELLER (3X9-1/4"X10-1/2"-J) HELICE (3X9-1/4"X10-1/2"-J)	1				UR UR
	683-45952-00-EL	PROPELLER (3X9-1/4"X9-3/4"-J) HELICE (3X9-1/4"X9-3/4"-J)	1				UR UR
-----							
-----							
-----							
-----							
-----							
-----							
-----							
-----							



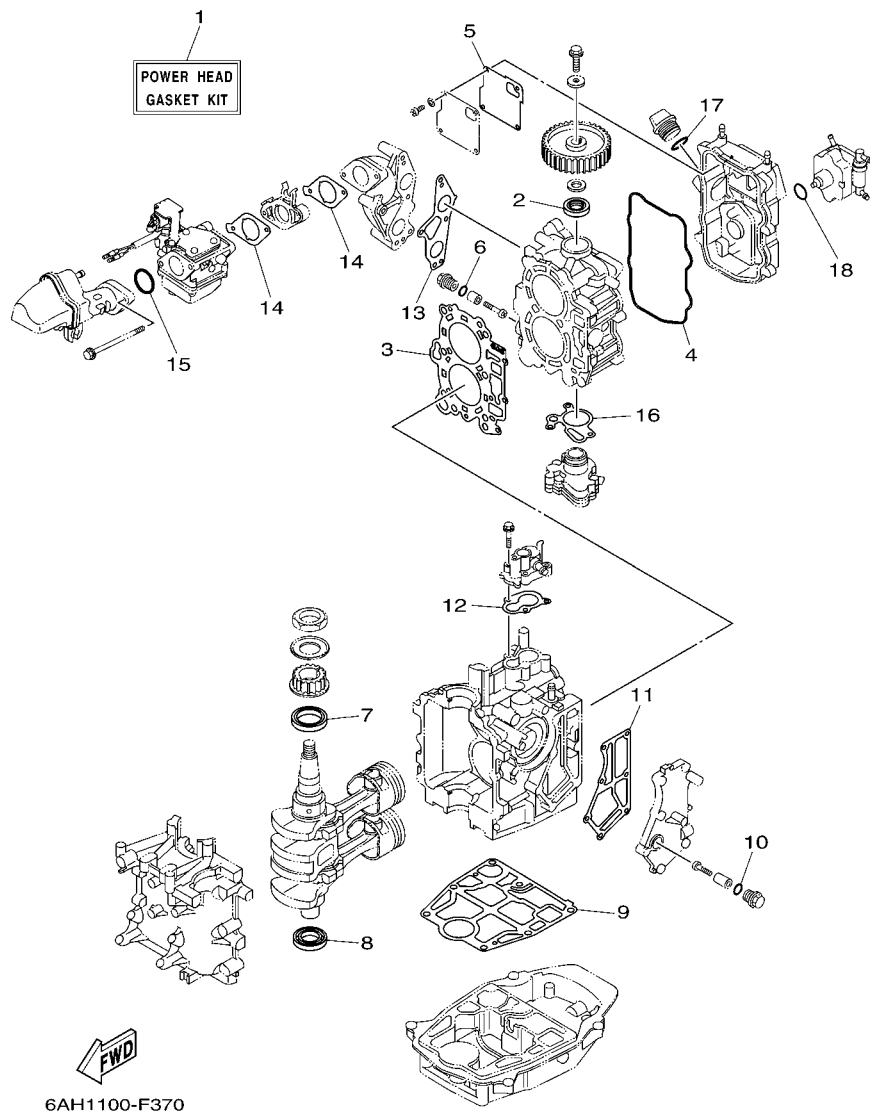

FIG. 26 REPAIR KIT 1

KITS DE REPARATION 1

REF. NO.	PART NO. N° PIECES	DESCRIPTION DESCRIPTION	6CA2				REMARKS REMARQUES
1	6AG-W0001-00	POWER HEAD GASKET KIT POCHETTE DE JINTS TETE MOTRICE	1				
2	93102-22009	.OIL SEAL .JOINT SPY	1				
3	6AG-11181-00	.GASKET, CYLINDER HEAD 1 .JOINT, DE CULASSE 1	1				
4	6AH-11356-00	.SEAL, CYLINDER 2 .JOINT, SPY CYLINDRE	1				
5	6AH-11169-00	.GASKET, BREATHER COVER .JOINT, COUVERCLE DE RENIFLARD	1				
6	93210-13M63	.O-RING .JOINT TORIQUE	2				
7	93102-37004	.OIL SEAL .JOINT SPY	1				
8	93102-25014	.OIL SEAL .JOINT SPY	1				
9	6AH-11351-00	.GASKET, CYLINDER .JOINT, D'EMBASE	1				
10	93210-13M63	.O-RING .JOINT TORIQUE	1				
11	6AH-41114-00	.GASKET, EXHAUST OUTER COVER .JOINT, COUVERCLE D'ECHAPPEMENT	1				
12	6AH-12414-00	.GASKET, COVER .JOINT, COUVERCLE	1				
13	6AH-13645-00	.GASKET, MANIFOLD 1 .JOINT, TUBULURE 1	1				
14	6AH-13646-00	.GASKET, MANIFOLD 2 .JOINT, TUBULURE 2	2				
15	93210-35M86	.O-RING .JOINT TORIQUE	1				
16	6AH-13329-00	.GASKET, PUMP COVER .JOINT, COUVERCLE DE POMPE	1				
17	93210-24M79	.O-RING .JOINT TORIQUE	1				
18	93210-20M65	.O-RING .JOINT TORIQUE	1				



FIG. 28 REPAIR KIT 3

KITS DE PEPARATION 3

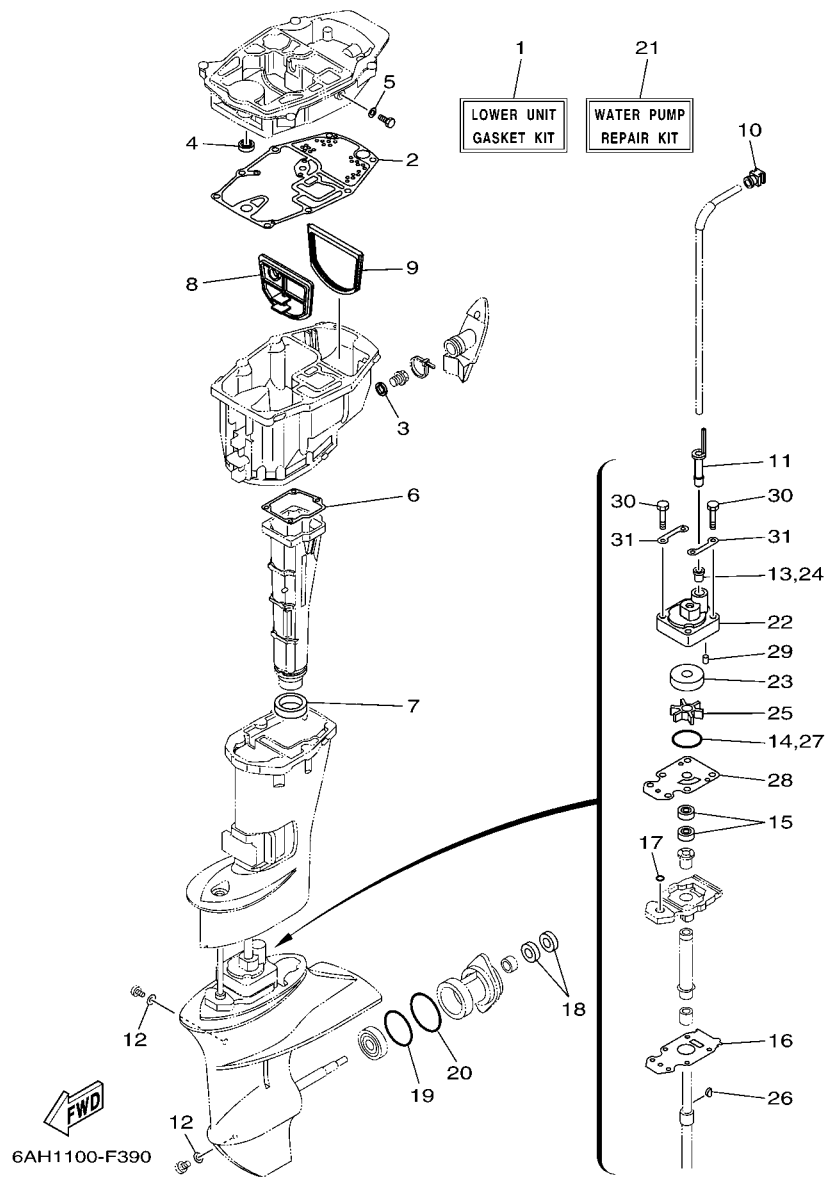

REF. NO.	PART NO. N° PIECES	DESCRIPTION DESCRIPTION	6CA2				REMARKS REMARQUES
1	6AH-W0001-20	LOWER UNIT GASKET KIT POCHETTE DE JOINTS EMBASE	1				
2	6AH-15312-00	.GASKET, OIL PAN .JOINT DE VENTILATEUR D'HUILE	1				
3	90430-14M09	.GASKET .JOINT	1				
4	93101-12M63	.OIL SEAL .JOINT SPY	1				
5	90430-08143	.GASKET .JOINT	1				
6	6AH-41134-00	.GASKET, EXHAUST MANIFOLD .JOINT, PIPE D'ECHAPPEMENT	1				
7	6AH-41138-00	.SEAL, EXT. 1 .JOINT DE GROUPE 1	1				
8	6AH-45126-00	.PLATE, SEAL DAMPER .PLAQUETTE	1				
9	6AH-45115-00	.GASKET, UPPER CASING .JOINT, TUBE D'ARBRE	1				
10	6AH-44365-00	.DAMPER, WATER SEAL .JOINT, TUBE D'EAU	1				
11	6AH-44368-00	.RUBBER, WATER SEAL 4 .CAOUTCHOUC EAU JUNTA 4	1				
12	90430-08020	.GASKET .JOINT	2				
13	6L2-44367-00	.DAMPER, WATER SEAL .JOINT TUBE D'EAU	1				
14	93210-49046	.O-RING .JOINT TORIQUE	1				
15	93101-20001	.OIL SEAL .JOINT SPY	2				
16	69G-45315-A0	.PACKING, LOWER CASING .JOINT, BOITIER D'HELICE	1				
17	93210-06ME6	.O-RING .JOINT TORIQUE	1				
18	93101-17054	.OIL SEAL .JOINT SPY	2				
19	93210-57M09	.O-RING .JOINT TORIQUE	1				
20	93210-56M80	.O-RING .JOINT TORIQUE	1				
21	6AH-W0078-00	WATER PUMP REPAIR KIT KIT DE REPARATION DE LA POMPE	1				
22	6AH-44311-00	.HOUSING, WATER PUMP .CORPS, POMPE A EAU	1				
23	63V-44322-00	.INSERT, CARTRIDGE .CUVETTE	1				
24	6L2-44367-00	.DAMPER, WATER SEAL .JOINT TUBE D'EAU	1				
25	63V-44352-01	.IMPELLER .TURBINE	1				
26	664-44338-00	.KEY, WOODRUFF .CLAVETTE, VOLANT	1				
27	93210-49046	.O-RING .JOINT TORIQUE	1				



NUMERICAL INDEX  
INDEX NUMERIQUE

PART NO. N° PIECES	REF. NO.	PART NO. N° PIECES	REF. NO.	PART NO. N° PIECES	REF. NO.	PART NO. N° PIECES	REF. NO.	PART NO. N° PIECES	REF. NO.	PART NO. N° PIECES	REF. NO.
6AH-11111-00-94	4 - 2	6AG-12170-00	8 - 1	65W-1439G-00	7 - 34	6F5-15779-02	10 - 17	6AG-28199-74-F0	9 - 38	6AH-42649-00	1 - 10
6AH-11133-10	4 - 3	6AH-12279-00	5 - 9	6AH-14427-60	10 - 30	6AH-15782-00	10 - 21	6AG-28199-74-G0	9 - 38	6AH-42651-00	1 - 4
6AH-11168-00	4 - 13	6AH-12411-00	2 - 17	6AH-14440-00	6 - 10	68T-15784-00	10 - 11	6AG-28199-74-H0	9 - 38	60R-42652-00	1 - 7
6AH-11169-00	4 - 14	688-12412-00	2 - 18	6AH-14497-00	18 - 30	6A0-15789-00	10 - 18	6AG-28199-74-S0	9 - 38	6CA-42677-00	1 - 11
	26 - 5	6AH-12413-00-1S	2 - 19	63V-14523-00	7 - 9	63V-15793-00	10 - 12	6AG-28199-84-K0	9 - 39	6CA-42681-00	1 - 13
6AG-11181-00	4 - 4	6AH-12414-00	2 - 20	6AH-14546-00	7 - 13	68T-15793-00	10 - 13	6AG-28199-84-L0	9 - 39	6CA-42682-00	1 - 14
	26 - 3		26 - 12		27 - 3	6AH-15793-00	10 - 22	6AG-28199-84-M0	9 - 39	6AH-42697-01	1 - 15
6AH-11191-00-1S	4 - 8	6AH-12481-00	2 - 24	6H4-14548-00	7 - 16	66T-15794-00	10 - 19	6AG-28199-84-N0	9 - 39	6AH-42710-00-4D	15 - 1
6G8-11197-01	2 - 13	6AH-12535-00	15 - 27		27 - 4	6AH-15795-00	10 - 4	6AG-28199-84-P0	9 - 39	6AH-42716-00	15 - 5
	4 - 19	68T-12572-00	15 - 23	67C-14555-00	7 - 21	6YK-24201-03	25 - 1	6AG-28199-84-R0	9 - 39	65W-42717-00	15 - 31
6E5-11325-00	2 - 26	6R3-12581-00	15 - 24	67C-14567-00	7 - 32	6YK-24260-01	25 - 4	6AH-41113-00-1S	2 - 8	6AH-41114-00	2 - 15
6G8-11325-00	2 - 11	6R3-12582-00	15 - 25	6AH-14571-10	18 - 25	6YL-24268-01	25 - 2	6AH-41134-00	21 - 7	6AH-42717-00	15 - 43
	2 - 22	6R3-12583-00	15 - 26	65W-14572-00	7 - 3	6G1-24304-02	9 - 1		26 - 11	6AH-42718-00	15 - 7
	4 - 17	6C5-12858-00	2 - 29	6AH-14711-00-5B	21 - 8	6YL-24306-54	25 - 7		21 - 7	6AH-42724-00	15 - 10
6AH-11351-00	2 - 7	66M-13131-10	9 - 19	6AH-14711-10-5B	21 - 8	6AH-24311-00	9 - 4		28 - 6	6AH-42725-00	15 - 9
	26 - 9	6AH-13300-00	8 - 15	67C-14923-20	7 - 19	6AH-24312-00	9 - 12	6AH-41137-00-5B	21 - 1	6G1-42725-00	12 - 41
6AH-11356-00	4 - 10	6AH-13329-00	8 - 16	676-14943-19	7 - 11	6AH-24313-00	9 - 28	6AH-41138-00	21 - 11	65W-42726-00	15 - 18
	26 - 4		26 - 16	6AH-14947-20	7 - 10	6AH-24314-01	15 - 21		28 - 7	6AH-42726-00	15 - 20
676-11372-00	2 - 10	6AH-13411-00	22 - 8	6AG-14948-02	7 - 6	6AH-24315-00	9 - 30	6AH-41211-00	18 - 20	6AH-42727-00	15 - 17
6AH-11372-00	4 - 9	67F-13434-10	1 - 17	679-14966-00	7 - 7	6AH-24316-00	10 - 29	6J8-41262-00	18 - 19	6AH-42735-00	1 - 16
6AH-11411-00	3 - 1	6AH-13437-60	10 - 31	6AH-14980-00	7 - 25	6AH-24317-00	9 - 33	6AH-41282-00	18 - 33	6AH-42735-30	14 - 6
6AH-11416-00	3 - 2	5GH-13440-20	2 - 28	6AH-14985-00	7 - 12	61N-24329-00	9 - 2	65W-41283-00	18 - 18	6AH-42735-40	14 - 7
6AH-11416-10	3 - 2	6AH-13641-00-94	6 - 1		27 - 10	6YL-24329-00	25 - 6	6AH-41638-00	18 - 16	6AH-42738-00-4D	15 - 6
6AH-11416-20	3 - 2	6AH-13645-00	6 - 2	65W-14992-00	7 - 27	66M-24374-00	9 - 25	6G1-41662-01-94	18 - 5	6AH-42741-00	15 - 38
6AH-11536-00	8 - 6		26 - 13	6AH-15100-00-1S	2 - 2	650-24378-00	2 - 9	6AH-42101-01-4D	16 - 2	6AH-42743-00	15 - 32
6AH-11537-00-94	8 - 2	6AH-13646-00	6 - 8	6AH-15311-00-5B	22 - 1	688-24378-00	9 - 34	66M-42119-00	16 - 5	6AH-42761-00	15 - 34
6AH-11557-00	8 - 7		26 - 14	6AH-15312-00	22 - 2	6C5-24378-00	9 - 35	65W-42125-00	16 - 11	6AH-42762-00	15 - 35
6AH-11603-00	3 - 6	65W-14126-10	7 - 4		28 - 2	6AH-24410-00	9 - 14	6G1-42126-00	16 - 10	6AH-42794-40	15 - 48
6AH-11604-00	3 - 6		27 - 2	6AH-15316-00	22 - 4	66M-24411-11	9 - 17	6AH-42131-00-4D	16 - 28	6AH-42794-50	15 - 49
6AH-11605-00	3 - 6	663-14159-00	7 - 14	6AH-15362-00	22 - 11	6AH-24413-00	9 - 15	6J0-42137-00	16 - 13	6AH-42801-00	15 - 11
6AH-11631-00	3 - 5		27 - 11	6G8-15363-00	4 - 21	6A0-24421-01	9 - 16	65W-42138-00	16 - 7	6AH-43111-00-4D	19 - 1
137-11633-10	3 - 7	6AH-14271-00	6 - 9	6AH-15373-00	6 - 13	66M-24423-00	9 - 18	65W-42159-00	16 - 9	6AH-43112-00-4D	19 - 6
6AH-11635-00	3 - 5	6AG-14301-11	7 - 1	63V-15705-01	10 - 9	66M-24444-00	9 - 21	62Y-42171-00	18 - 27	66R-43113-00	19 - 13
6AH-11636-00	3 - 5	6E7-14325-00	9 - 23	6AH-15710-01	10 - 1	66M-24454-00	9 - 20	67D-42177-00	16 - 6	648-43114-01	19 - 5
6AH-11650-00	3 - 3	65W-14335-00	7 - 22	6AH-15711-00	10 - 2	66M-24471-01	9 - 22	6AH-42508-00	17 - 1		19 - 10
6AH-11654-00	3 - 4	65W-14346-00	7 - 33	63V-15713-00	10 - 7	61N-24521-00	9 - 7	6AH-42510-00-4D	20 - 1	6E7-43116-00	19 - 4
6AH-12111-00	5 - 1	6AH-14346-00	7 - 31	63V-15714-00	10 - 5	61N-24560-00	9 - 5	6AH-42510-10-4D	20 - 1		19 - 9
3YF-12113-00	5 - 4	6AH-14371-00	7 - 23	68T-15716-00	10 - 8	61N-24563-00	9 - 6	68T-42525-01	17 - 2	6E0-43118-01	19 - 2
62Y-12116-00	5 - 3	65W-14373-02	7 - 17	66T-15731-00	10 - 24	6AH-24566-00	9 - 9	6AH-42527-00	17 - 15		19 - 7
30X-12117-00	5 - 5		27 - 5	66T-15734-00	10 - 20	6YK-24610-01	25 - 3	65W-42528-00	17 - 8	69A-43131-00	19 - 11
30X-12118-00	5 - 6	6AH-14379-00	7 - 18	6AH-15741-10	10 - 6	6AH-26288-00	16 - 4	6AH-42532-00	16 - 30	68T-43155-00	17 - 18
51Y-12119-00	5 - 7	6AH-14380-00	7 - 29	689-15755-01	10 - 15	6AH-26311-00	16 - 18	6AH-42551-00	16 - 23	6L2-43160-01	19 - 19
6AH-12121-00	5 - 2	6AH-14384-00	7 - 24	6AH-15762-00	10 - 28	6AH-26326-00	15 - 15	68T-42561-00	17 - 6	689-43165-00	19 - 20
62Y-12138-60	4 - 24		27 - 7	67D-15764-00	10 - 3	6AH-2634E-00	16 - 22	67C-42562-00	17 - 4	6AH-43191-00	19 - 28
66M-12146-00	5 - 8	67C-14397-00	7 - 20	68T-15764-00	10 - 14	6AH-26364-00	18 - 4	6CA-42610-00-4D	1 - 1	6AH-43311-00-4D	19 - 23
6AH-12151-00	5 - 13		27 - 6	63V-15767-01	10 - 10	62Y-28100-00	9 - 37	6AH-42613-00	1 - 2	6AH-43311-10-4D	19 - 23
62Y-12158-00	5 - 15	65W-14398-00	7 - 26	6AH-15770-00	10 - 23	6AG-28199-74-D0	9 - 38	6AH-42615-00	1 - 6	6AH-43350-00	19 - 32
64J-12159-00	5 - 14		27 - 8	6AH-15774-00	15 - 44	6AG-28199-74-E0	9 - 38	6AH-42617-00	8 - 13	68T-43611-00	19 - 37

NUMERICAL INDEX  
INDEX NUMERIQUE

PART NO. N° PIECES	REF. NO.	PART NO. N° PIECES	REF. NO.	PART NO. N° PIECES	REF. NO.	PART NO. N° PIECES	REF. NO.	PART NO. N° PIECES	REF. NO.	PART NO. N° PIECES	REF. NO.
6AH-43614-00	19 - 34	6AH-44551-00-4D	20 - 12	682-45631-00	23 - 37	6AH-85540-00	12 - 1	90157-05M16	25 - 5	90387-05M11	17 - 10
6AH-43615-00	19 - 36	6AH-44554-00	16 - 19	648-45633-00	23 - 39	6AH-85542-00	12 - 21	90167-06002	15 - 28	90387-06138	19 - 38
6AH-43616-00	19 - 25	6AH-44555-00	20 - 14	650-45635-00	23 - 36	6AH-85547-00	14 - 10	90170-06015	18 - 14	90387-06139	18 - 21
6AH-43617-00	19 - 30	6AH-44557-00	20 - 13	683-45941-00-EL	24 - 22	6AH-85550-00	11 - 1	90170-30003	8 - 8	90387-06176	15 - 4
6AH-43627-00	19 - 42	6AH-44574-00	20 - 15	63V-45941-10-EL	24 - 22	6F5-85570-13	12 - 13	90171-10M01	24 - 18	90387-06M13	19 - 15
6AH-43631-00	19 - 24	6AH-45111-00-4D	21 - 12	683-45943-00-EL	24 - 22	6AH-85580-00	11 - 3	90179-08M06	23 - 30	90387-06M60	12 - 8
689-43633-00	17 - 7	6AH-45111-10-4D	21 - 12	63V-45943-10-EL	24 - 22	6AG-W0001-00	26 - 1	90179-08M34	20 - 18	90387-06M70	13 - 19
6AH-43641-00	19 - 27	6AH-45115-00	22 - 15	63V-45945-10-EL	24 - 22	6AH-W0001-20	28 - 1	90179-16M05	11 - 8	90387-06M86	16 - 35
6AH-43646-00	19 - 26		28 - 9	683-45952-00-EL	24 - 22	6CA-W0070-00	1 - 12	90185-05002	24 - 11	90387-13006	5 - 11
68T-43659-00	19 - 40	6AH-45126-00	22 - 14	63V-45952-10-EL	24 - 22	6AH-W0078-00	28 - 21	90185-10M14	17 - 14	90430-08020	23 - 10
6AH-44111-00	16 - 33		28 - 8	6E7-45987-01	24 - 16	6AH-W0084-01-4D	16 - 1	90185-22043	19 - 14		28 - 12
66R-44114-00	18 - 11	6AH-45135-00	22 - 16	6AH-46241-00	8 - 10	6AH-W0093-01	27 - 1	90201-05M04	18 - 28	90430-08143	21 - 5
65W-44116-00	18 - 10	6G1-45214-00	24 - 8	6AH-46297-00	8 - 11	6AG-W009A-00-1S	4 - 1	90201-06M05	12 - 12		28 - 5
6AH-44121-00	18 - 3	63V-45215-00	24 - 9	6AH-81948-00	12 - 5	6AH-W009B-00-1S	2 - 1	90201-06M31	18 - 22	90430-14M09	22 - 7
6AH-44123-00	18 - 1	6AH-45251-00	24 - 12	6AH-81949-00	13 - 12	90101-06M18	19 - 16	90201-08065	17 - 17		28 - 3
6AH-44124-00	16 - 37	6AH-45300-00-4D	23 - 1	6AH-81960-00	13 - 16	90101-08022	17 - 16	90201-08784	8 - 4	90445-08029	14 - 3
6AH-44125-00	18 - 8	6AH-45300-10-4D	23 - 1	6AH-81994-40	8 - 19	90105-06035	8 - 17	90201-10M01	24 - 17	90445-09026	9 - 31
6AH-44143-00	18 - 13	6AH-45311-00-4D	23 - 2	6AH-81994-50	8 - 20	90105-081A7	8 - 3	90201-15017	23 - 6	90446-06M90	10 - 25
6AH-44143-10	18 - 13	69G-45315-A0	23 - 24	6AH-81995-40	10 - 32	90105-09006	4 - 6	90201-15423	8 - 5	90464-06001	13 - 15
6AH-44150-00	23 - 27		28 - 16	6AH-81995-50	10 - 33	90109-06215	9 - 26	90201-16M44	11 - 9	90464-07M56	12 - 22
6AH-44150-10	23 - 27	626-45316-09	23 - 22	703-82119-00	11 - 4	90109-06221	12 - 4	90201-17682	23 - 34	90464-08004	13 - 1
6AH-44167-00	18 - 26	682-45318-00	21 - 21		13 - 17	90109-06M82	15 - 8	90201-39008	16 - 25	90464-09010	13 - 7
6X4-44188-00	16 - 15	68T-45321-00	21 - 18	6AH-82127-00	20 - 20	90109-06M84	19 - 43	90202-10M56	17 - 5	90464-09018	9 - 36
6G8-44191-00	16 - 40	69G-45331-01-5B	23 - 21	67F-82151-00	13 - 13	90109-06M86	12 - 29	90206-10M24	19 - 44	90464-10M32	12 - 40
6AH-44311-00	23 - 11	683-45361-02-4D	23 - 41	67F-8215B-00	13 - 14		12 - 44	90206-15M18	16 - 36	90464-16003	12 - 42
	28 - 22	6AH-45371-00-4D	24 - 20	67F-82361-00	12 - 15		15 - 33	90206-39001	16 - 26	90464-18246	12 - 38
63V-44322-00	23 - 12	63V-45375-00	24 - 15	6AH-82370-00	12 - 18		15 - 45	90209-10M26	17 - 13		13 - 5
	28 - 23	6AH-45510-00	23 - 28	6C5-82377-00	15 - 47		16 - 3	90209-14011	23 - 5	90464-20181	14 - 11
68T-44323-00	23 - 17	6AH-45510-10	23 - 28	6AH-82388-00	12 - 28	90109-06MA1	6 - 14	90209-40008	20 - 2	90465-08059	4 - 23
	28 - 28	63V-45536-00	23 - 4	6AH-82389-00	12 - 43	90111-06072	16 - 31	90243-04M01	19 - 3	90465-08M82	15 - 46
63V-44328-00	23 - 20	63V-45551-00	23 - 29	6AH-82398-00	13 - 4	90111-08055	9 - 11		19 - 8	90465-08M83	6 - 5
	28 - 31	6E7-45560-01	23 - 31	64J-82504-00	12 - 23	90116-10033	20 - 7	90250-05010	23 - 38	90465-11M10	2 - 25
664-44338-00	23 - 15	664-45567-01	23 - 49	6AH-82522-00	12 - 10	90119-05018	17 - 3	90254-03M05	18 - 2		9 - 32
	28 - 26	664-45567-10	23 - 49	6AH-82554-00	12 - 35	90119-06M05	16 - 34		18 - 9		12 - 34
63V-44352-01	23 - 14	664-45567-20	23 - 49	682-82556-00	16 - 42	90119-06M35	12 - 7	90266-06M02	1 - 5		15 - 16
	28 - 25	664-45567-30	23 - 49	6AH-82560-00	12 - 30	90119-06M88	24 - 21	90269-02M09	16 - 14		15 - 22
6AH-44361-00	24 - 1	664-45567-40	23 - 49	6AH-82575-00	16 - 41	90119-06MA3	2 - 16	90280-03M01	8 - 9		24 - 3
6AH-44361-10	24 - 1	664-45567-50	23 - 49	689-8257Y-00	16 - 43		2 - 21	90280-05013	11 - 7	90465-11M59	22 - 5
6AH-44365-00	24 - 2	664-45567-60	23 - 49	6AH-82588-00	12 - 31		4 - 7	90340-08002	23 - 9	90465-13M18	6 - 16
	28 - 10	6E7-45571-00	23 - 32	6AH-8259M-10	14 - 1	90119-08093	2 - 4	90340-14M06	22 - 6		12 - 6
6L2-44367-00	23 - 13	626-45577-00	23 - 33	6H4-83589-00	12 - 25	90119-08094	20 - 11	90381-20001	16 - 27		12 - 39
	28 - 13	626-45577-10	23 - 33	62Y-84301-00	12 - 24	90119-08102	22 - 13	90386-08004	16 - 17		13 - 6
	28 - 24	626-45577-20	23 - 33	68F-85119-00	15 - 2	90119-08103	22 - 12	90386-22MA4	19 - 12		14 - 2
6AH-44368-00	24 - 4	626-45577-30	23 - 33	67C-85415-00	12 - 45	90119-08M45	20 - 16	90386-30048	20 - 4	90467-09M17	9 - 13
	28 - 11	626-45577-40	23 - 33	6AH-85510-00	11 - 2	90119-08M46	20 - 17	90386-30M60	20 - 6		9 - 29
6BL-44391-00	15 - 14	6E8-45587-10	23 - 7	6AH-8552A-00	14 - 4	90149-05M13	16 - 8	90386-40001	20 - 3	90468-10005	18 - 29
6AH-44514-00-94	20 - 8	6E8-45587-30	23 - 7	6AH-8552E-00	14 - 5	90149-06069	18 - 34	90386-45001	16 - 24	90468-18008	16 - 39
6AH-44526-00	20 - 9	683-45611-00	23 - 35	6AH-85537-00	14 - 8	90152-05M04	24 - 10	90387-05M05	17 - 9	90480-06M19	8 - 14

NUMERICAL INDEX  
INDEX NUMERIQUE

PART NO. N° PIECES	REF. NO.	PART NO. N° PIECES	REF. NO.	PART NO. N° PIECES	REF. NO.	PART NO. N° PIECES	REF. NO.	PART NO. N° PIECES	REF. NO.	PART NO. N° PIECES	REF. NO.
90480-10627	8 - 12	92995-06600	18 - 7	93604-12M07	21 - 15	97095-06014	18 - 31				
90480-10M23	12 - 9		18 - 32		22 - 3	97095-06016	12 - 36				
90480-13M24	13 - 20		21 - 10		23 - 18	97095-06020	4 - 11				
90480-14M54	21 - 20		23 - 48		24 - 5		10 - 26				
90480-16007	15 - 19	92995-08600	13 - 9		28 - 29		12 - 2				
90480-16616	6 - 15		13 - 11	93606-12019	2 - 3		18 - 6				
90480-19368	14 - 9		21 - 14		4 - 5	97095-06025	12 - 16				
90480-21M82	15 - 3		24 - 7	93606-19M23	21 - 6	97095-08014	21 - 4				
90480-25003	12 - 14	93101-12M63	21 - 2	93700-06M03	20 - 19	97095-08016	13 - 10				
90501-10326	7 - 8		28 - 4	94702-00418	4 - 25	97095-08025	13 - 8				
90501-120A5	5 - 12	93101-17054	23 - 44	95380-04600	9 - 24	97595-06555	6 - 3				
90501-150A0	23 - 40		28 - 18	95380-06600	15 - 42		16 - 29				
90501-23215	16 - 16	93101-20001	23 - 23	95380-06700	18 - 15		18 - 23				
90502-10M07	19 - 22		28 - 15		19 - 18	97780-50616	1 - 3				
90506-18014	19 - 33	93102-22009	8 - 18	95380-08600	9 - 10	97780-60520	16 - 32				
90506-20020	19 - 35		26 - 2	95380-10600	20 - 10	97880-05025	2 - 12				
90508-20M44	18 - 17	93102-25014	3 - 10	95780-06500	13 - 21		2 - 23				
91490-16010	16 - 12		26 - 8	95895-06014	18 - 12		4 - 18				
91490-30020	24 - 19	93102-37004	3 - 9	95895-06020	9 - 3	97880-06010	12 - 11				
91690-30008	19 - 21		26 - 7	95895-06030	11 - 6	97885-06012	12 - 26				
91690-50014	6 - 4	93210-06ME6	23 - 25	95895-06035	24 - 13	97885-06030	15 - 39				
92903-06600	2 - 6		28 - 17	95895-06100	6 - 12	97980-04108	7 - 30				
	22 - 10	93210-13M63	2 - 14	97013-06012	5 - 10	97980-04110	7 - 5				
92907-04600	4 - 16		4 - 20	97013-06016	22 - 9	97980-04114	7 - 28				
92990-06200	16 - 38		26 - 6	97013-06040	2 - 5		27 - 9				
92990-06300	24 - 14		26 - 10	97075-06012	15 - 36	97985-06214	14 - 14				
92990-06600	19 - 17	93210-20M65	9 - 27	97075-06020	23 - 47	98507-04010	4 - 15				
92995-05600	1 - 9		26 - 18	97075-06025	21 - 9	98580-04006	7 - 2				
	17 - 12	93210-24M79	4 - 22	97075-08030	21 - 13	98580-04008	7 - 15				
	21 - 17		26 - 17		24 - 6	98780-04016	2 - 27				
92995-06100	15 - 40	93210-29M94	20 - 5	97080-08025	23 - 26	98980-06030	13 - 18				
92995-06600	4 - 12	93210-32738	9 - 8	97080-08045	23 - 19	99080-05600	19 - 29				
	6 - 7	93210-35M86	6 - 11		28 - 30		19 - 31				
	10 - 27		26 - 15	97095-05010	21 - 16		19 - 41				
	12 - 3	93210-49046	23 - 16	97095-05012	11 - 5						
	12 - 17		28 - 14	97095-05014	1 - 8						
	12 - 20		28 - 27	97095-05020	17 - 11						
	12 - 27	93210-56M80	23 - 46	97095-06008	21 - 19						
	12 - 33		28 - 20	97095-06010	15 - 29						
	12 - 37	93210-57M09	23 - 45	97095-06012	6 - 6						
	13 - 3		28 - 19		15 - 12						
	13 - 23	93306-00501	23 - 42	97095-06014	12 - 19						
	14 - 13	93315-314V8	23 - 3		12 - 32						
	15 - 13	93315-317U2	23 - 43		13 - 2						
	15 - 30	93332-00005	23 - 8		13 - 22						
	15 - 37	93420-30042	21 - 22		14 - 12						
	15 - 41	93430-04M03	19 - 39		16 - 20						
	16 - 21	93450-17129	3 - 8		18 - 24						